

Thank you for choosing Sunnydaze Decor. We stand behind our brand and the quality of the items we sell. Replacement parts or products will be sent at our discretion within the 1-year warranty period. Proof of purchase, with the date of purchase as well as photos of the merchandise defect, must be provided. Photos are used to determine the cause of defects and for future quality control. Register your warranty at www.serenityhealth.com/warranty/

If you have any questions, comments or concerns, feel free to contact us by phone at 888-881-4668, by email: customerservice@serenityhealth.com, or via our contact us page at www.SerenityHealth.com/contact-us/

3-PERSON PATIO SWING WITH SIDE TABLES





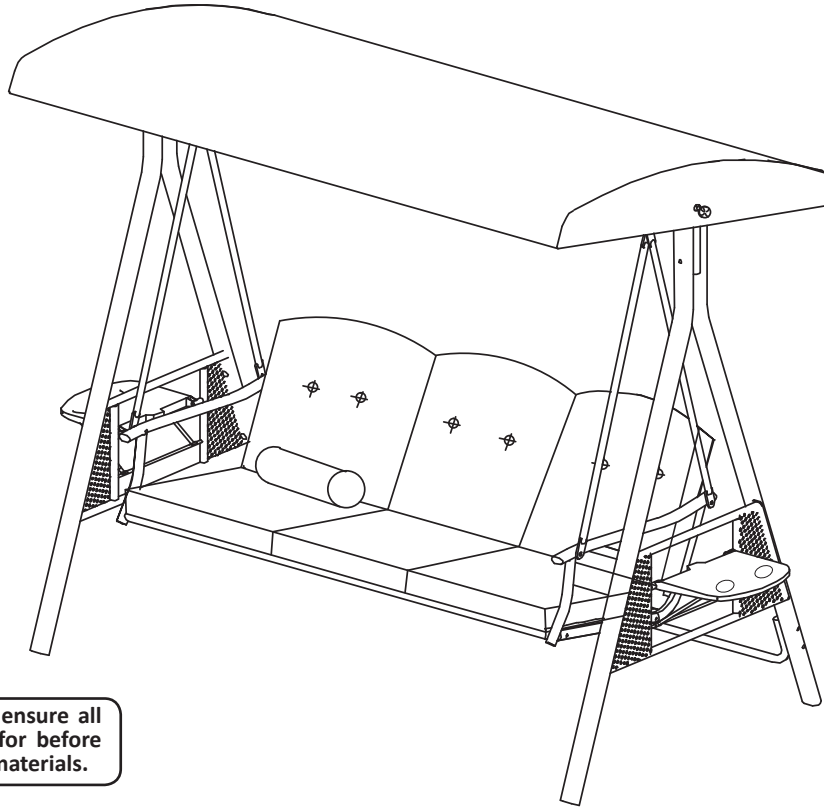





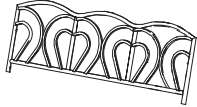
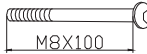



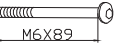

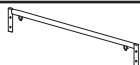



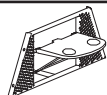

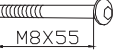
LR-819 / LR-826

Read all assembly and care instructions carefully before using this product. Save these instructions for future reference.
Assemble components on a soft, clean surface to avoid scratching/damaging the finish.

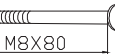

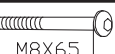
Inspect packaging to ensure all parts are accounted for before disposing of packing materials.

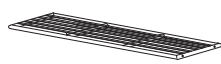
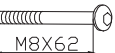

No.	FRAME	QTY.	No.	FRAME	QTY.	No.	FRAME	QTY.	No.	FRAME	QTY.
A		2	H		1	M	 M8X100	4	W		M6: 4 M8: 14
B		2	I		2	N	 M6X89	4	X		M6: 12 M8: 14
C		1	J		1	O	 M6X20	8	Y		2
D		2	J1		1	P	 M8X55	2	Z		M6: 4 M8: 14
E		4	K		1	Q	 M8X80	2	AA		1
F		1				R	 M8X65	4	BB		1
G		1				S	 M8X62	2	CC		1
						T		3			

WARNING!

CHOKING HAZARD — This item contains small parts that can be swallowed. Keep children away during assembly.

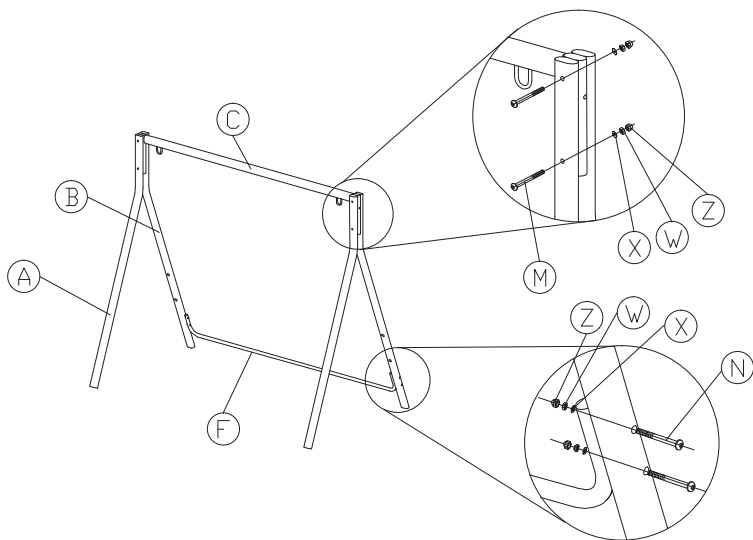
Fig. 1

- Attach Front Leg (A) and Back Leg (B) to Top Bar (C) using Bolts (M) and M8 hardware (X+W+Z).
- Connect Back Support (F) to Back Legs (B) using Bolts (N) and M6 hardware (X+W+Z).

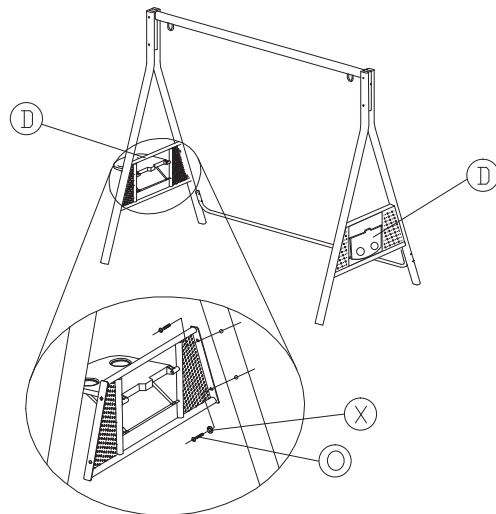
Fig. 2

- Fasten Side Table Panels (D) to the front and back legs using Bolts (O) and M6 Washers (X).

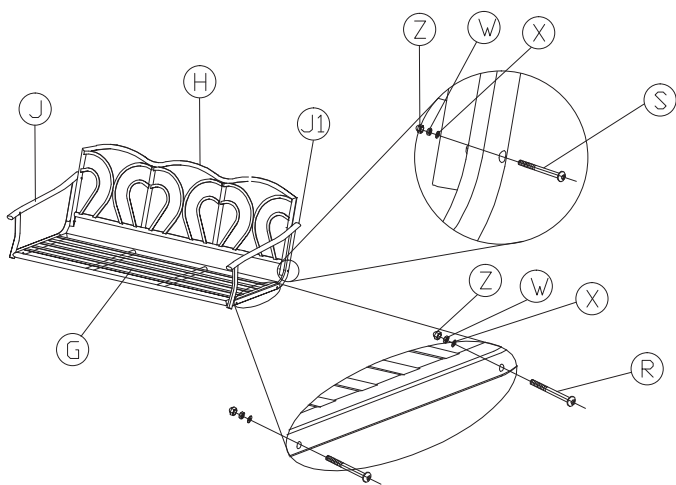
Fig. 3

- Attach Right Armrest (J) and Left Armrest (J1) to Seat (G) using Bolts (R) and M8 hardware (X+W+Z).
- Connect Seat Back (H) to the armrests using Bolts (S) and M8 hardware (X+W+Z).

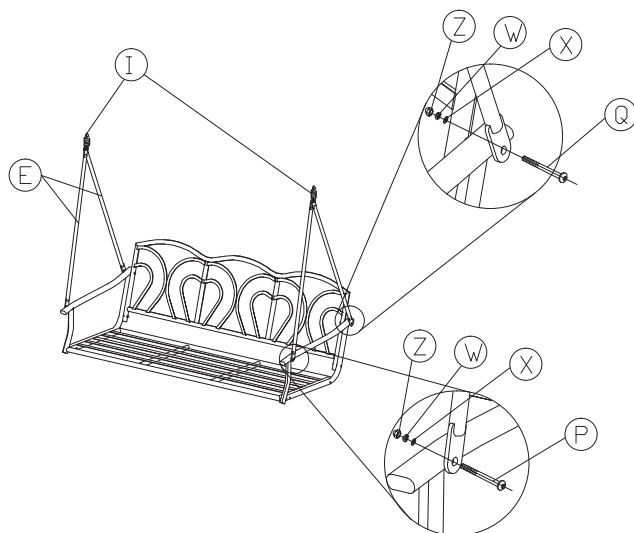
Fig. 4

- Connect Swing Arms (E) to the back-side of each armrest using Bolts (Q) and M8 hardware (X+W+Z).
- Connect Swing Arms (E) to the front of each armrest using Bolts (P) and M8 hardware (X+W+Z).
- Secure the top of the swing arms with Extension Springs (I).

Fig. 5

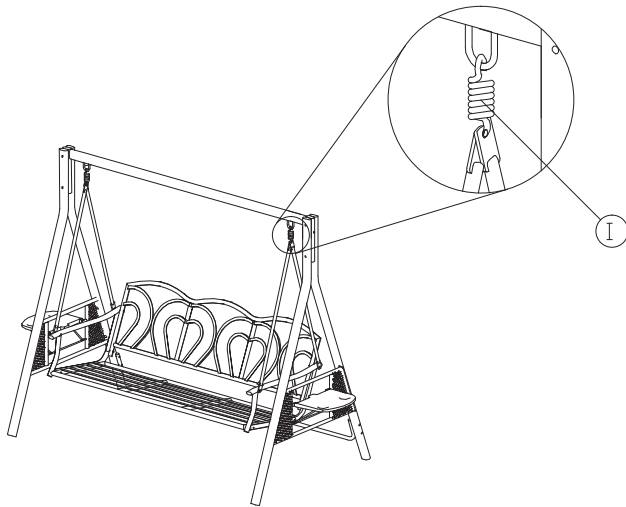

- Hang the assembled swing on the frame, as shown.

Fig. 6

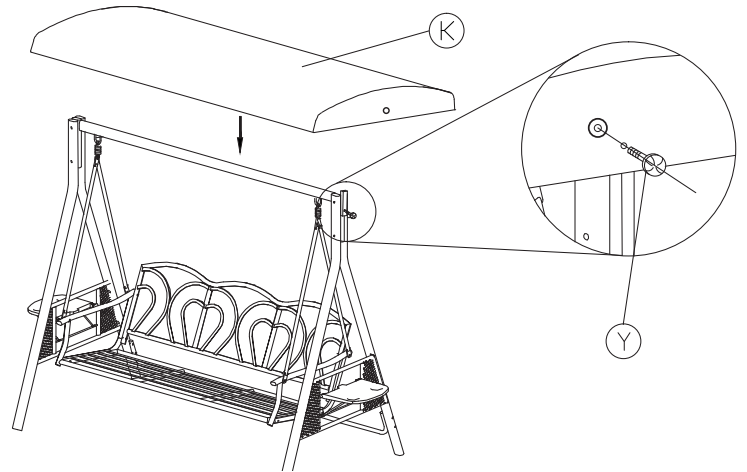

- Open Canopy (L) and align the holes of the canopy frame with the swing frame. Secure the canopy to the frame using Threaded Knobs (Y).

Fig. 7

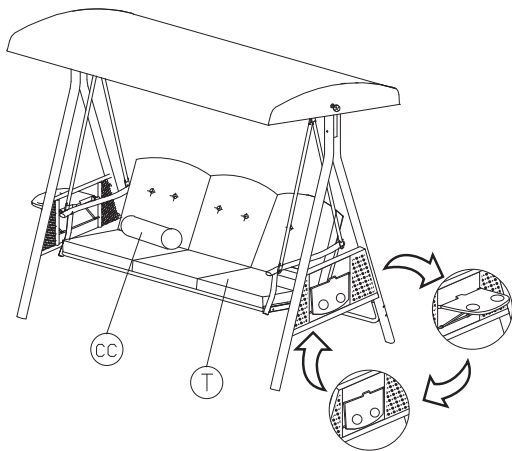

- Place Cushions (T) on the seat. Secure the cushions to the swing using the hook and loop fasteners sewn onto the back of each cushion.
- Flip the table up and extend the arms out from the bottom of the table. Lock the arms in place by pressing them onto the thin bar on the side table panel.

****Do not push down on the table surface to secure the arms, doing so may damage the table and will cause it to warp.**

USE & CARE

- **SAFE USE:** Swinging, bouncing, jumping and other excessive movement while using the patio swing may cause serious injury including, but not limited to, the swing tipping over.
- **INSPECTION:** Ensure the stand is assembled correctly and all hardware is securely fastened.
- **SWINGING:** While in a seated position with feet in contact with the ground, gently move the swing in a front-to-back direction.
- **CHILDREN:** Supervise children at all times. Do not allow children to play or sleep on swing.
- **CLEANING:** Use a soft cloth and warm water to wipe down cushions, canopy and frame. Dry the frame after cleaning to prevent rust.
- **PROTECTING:** When not in use, cover the porch swing with a breathable outdoor furniture cover to protect from the elements and extend the life of the finish. Cover not included.
- **STORAGE:** Store the cushions and canopy indoors when not in use. Cool, dry locations are recommended to prevent damage that may result from exposure to moisture.
- **SCRATCHES:** The powder coating on the stand is tough and durable but, even with normal use, some scratching is inevitable. To avoid excessive rust, wipe scratched areas with a soft cloth to remove moisture.



SAFETY STATEMENTS & WARNINGS



- Do not exceed the weight limit.
- Do not stand on any part of this item.
- Do not sit on or place heavy objects on the side tables.
- Use care when getting in and out of the swing.
- Keep feet in contact with the ground while swinging. Excessive swinging movement can cause the swing to tip over.
- Remove and store the canopy during windy conditions to prevent lifting and tipping.
- Inspect the swing and frame to ensure all hardware is securely installed and tightened before each use.
- Do not allow children to use this product without adult supervision.

Any modification or failure to follow the recommended care will void the product warranty.

WARNING:

Manufacturer and seller expressly disclaim any and all liability from personal injury, property damage or loss, whether direct or indirect, or incidental, resulting from the incorrect attachment, improper use, inadequate maintenance, or neglect of this product.