



2022/2023

# PRODUCT CATALOG



DK2 is a leading manufacturer of power products and automotive accessory items. Our line has expanded into 6 categories of products; Snow Plows, Outdoor Power Equipment, Trailers, Auto Accessories, Winches and our newest addition: Cordless Tools.

We believe in providing quality first and are focused on delivering our products to our customers on time and in accordance with their ever changing needs.

We believe that our business can – and should – have a positive impact on the communities we serve.

With Distribution Centres in both Canada and the US, we service a wide range of wholesale and retail channels by maintaining our commitment of providing products that are designed and created with high ethical standards.

**DKA** SNOWPLOWS<sup>®</sup>





## HITCH-MOUNTED SNOW PLOW

### ITEM NUMBER / UPC

AVAL8219 / 826518004992  
 AVAL8422 / 826518005005  
 AVAL8826 / 826518005708

### FEATURES

- Fits most light trucks and SUV's
- Easy to mount - simply slides into a 2" class III front mount receiver in seconds. Slide out and roll away for storage **1**
- An electric winch lifts the blade, controlled from inside your warm vehicle for easy up and down snow control **2**
- Blade angles set and lock manually with a single lever lifting a pin to 3 blade locking positions: straight on, angled to the right, and angled to the left
- Powder coated all-steel with UV protected paint **3**
- Wireless remote control included with the kit **4**
- Flip down locking castors allow easy plow attachment, removal, and roll away storage - just lower the wheels and roll the unit to wherever you want it
- Each snow plow kit also includes a set of blade stiffeners for added strength
- ISO 9001 certified manufacturer
- 1-year limited warranty



### DESCRIPTION

The DK2 Universal T-Frame Mounted Snow Plows allow you to quickly and effectively remove snow from your driveway or small parking lot. These plows simply slide into a 2" front mount receiver for easy removal and storage.

Each snow plow ships in a single carton complete with hardened steel cutting edge scraper, rubber snow deflector, polymer-wrapped wire rope plow markers, skid shoes, castor kit for easy storage, and a 3,000lb wireless electric winch. Each plow kit will also include a set of blade stiffeners for added strength by creating a 3 point connection.

### SPECIFICATION

ITEM NUMBER	<b>AVAL8219</b>
BLADE DIMENSIONS	82" (W) x 19" (H) 208.3cm (W) x 48.3cm (H)
ASSEMBLED WEIGHT	265lb (120.2kg)
SHIPPING WEIGHT	288lb (130.6kg)
SHIPPING DIMENSIONS	43" (L) x 32" (W) x 18" (H) 109.2cm (L) x 81.3cm (W) x 45.7cm (H)

ITEM NUMBER	<b>AVAL8422</b>
BLADE DIMENSIONS	84" (W) x 22" (H) 213.4cm (W) x 55.9cm (H)
ASSEMBLED WEIGHT	283lb (128.4kg)
SHIPPING WEIGHT	296lb (134.3kg)
SHIPPING DIMENSIONS	44" (L) x 32" (W) x 18" (H) 111.8cm (L) x 81.3cm (W) x 45.7cm (H)

ITEM NUMBER	<b>AVAL8826</b>
BLADE DIMENSIONS	88" (W) x 26" (H) 223.5cm (W) x 66cm (H)
ASSEMBLED WEIGHT	296lb (134.3kg)
SHIPPING WEIGHT	341lb (154.7kg)
SHIPPING DIMENSIONS	46" (L) x 35" (W) x 17" (H) 116.8cm (L) x 88.9cm (W) x 43.2cm (H)





### DESCRIPTION

The DK2 Universal T-Frame Mounted ELITE Series Snow Plows allow you to quickly and effectively remove snow from your driveway or small parking lot. These plows simply slide into a 2" front mount receiver for easy removal and storage. Each snow plow ships complete with hardened steel cutting edge scraper, rubber snow deflector, polymer-wrapped wire rope plow markers, skid shoes, castor kit, and a wireless electric actuator for extra strength and reliability. Each plow kit will also include a set of blade stiffeners for added strength by creating a 3 point connection.

### SPECIFICATION

ITEM NUMBER	AVAL8219ELT
BLADE DIMENSIONS	82" (W) x 19" (H) 208.3cm (W) x 48.3cm (H)
ASSEMBLED WEIGHT	265lb (120.2kg)
SHIPPING WEIGHT	321lb (145kg)
SHIPPING DIMENSIONS	46" (L) x 36" (W) x 18" (H) 116.8cm (L) x 91.4cm (W) x 45.7cm (H)
ITEM NUMBER	AVAL8422ELT
BLADE DIMENSIONS	84" (W) x 22" (H) 213.4cm (W) x 55.9cm (H)
ASSEMBLED WEIGHT	283lb (128.4kg)
SHIPPING WEIGHT	334lb (151.5kg)
SHIPPING DIMENSIONS	44" (L) x 32" (W) x 18" (H) 111.8cm (L) x 81.3cm (W) x 45.7cm (H)
ITEM NUMBER	AVAL8826ELT
BLADE DIMENSIONS	88" (W) x 26" (H) 223.5cm (W) x 66cm (H)
ASSEMBLED WEIGHT	296lb (134.3kg)
SHIPPING WEIGHT	341lb (154.7kg)
SHIPPING DIMENSIONS	46" (L) x 35" (W) x 17" (H) 116.8cm (L) x 88.9cm (W) x 43.2cm (H)



- Fits most light trucks and SUV's
- Easy to mount - simply slides into a 2" class III front mount receiver in seconds. Slide out and roll away for storage **1**
- An electric actuator lifts the blade, controlled from inside your warm vehicle for easy up and down snow control with built-in clutch, a strong chain, and uses less amperage than the winch, built with a completely sealed gearbox and housing and IP67 dust and water rated **2**
- Blade angles set and lock manually with a single lever lifting a pin to 3 blade locking positions: straight on, angled to the right, and angled to the left
- Powder coated all-steel with UV protected paint **3**
- Wireless remote control included with the kit **4**
- Flip down locking castors allow easy plow attachment, removal, and roll away storage - just lower the wheels and roll the unit to wherever you want it
- Each snow plow kit also includes a set of blade stiffeners for added strength
- ISO 9001 certified manufacturer
- 1-year limited warranty
- Ships in a single carton on a standard size pallet

## CUSTOM MOUNTED SNOW PLOW



### DESCRIPTION

All DK2 Snow Plows allow you to quickly & effectively remove snow from your driveway or small parking lot. DK2's range of personal plows each mount on to a vehicle specific custom mounting brackets.

Ships in a single carton complete with hardened steel cutting edge scraper, rubber snow deflector, polymer-wrapped wire rope plow markers, skid shoes, castor kit for easy storage, and a 3,000lb wireless electric winch.

### SPECIFICATION

<b>ITEM NUMBER</b>	<b>RAMPAGE II • RAMP8219</b>
<b>BLADE DIMENSIONS</b>	82" (W) x 19" (H) 208.3cm (W) x 48.3cm (H)
<b>ASSEMBLED WEIGHT</b>	265lb (120.2kg)
<b>SHIPPING WEIGHT</b>	280lb (127kg)
<b>SHIPPING DIMENSIONS</b>	43" (L) x 32" (W) x 18" (H) 109.2cm (L) x 81.3cm (W) x 45.7cm (H)
<b>ITEM NUMBER</b>	<b>STORM II • STOR8422</b>
<b>BLADE DIMENSIONS</b>	84" (W) x 22" (H) 213.4cm (W) x 55.9cm (H)
<b>ASSEMBLED WEIGHT</b>	283lb (128.4kg)
<b>SHIPPING WEIGHT</b>	287lb (130.2kg)
<b>SHIPPING DIMENSIONS</b>	43" (L) x 32" (W) x 18" (H) 109.2cm (L) x 81.3cm (W) x 45.7cm (H)
<b>ITEM NUMBER</b>	<b>SUMMIT II • SUMM8826</b>
<b>BLADE DIMENSIONS</b>	88" (W) x 26" (H) 223.5cm (W) x 66cm (H)
<b>ASSEMBLED WEIGHT</b>	296lb (134.3kg)
<b>SHIPPING WEIGHT</b>	301lb (136.5kg)
<b>SHIPPING DIMENSIONS</b>	46" (L) x 35" (W) x 17" (H) 116.8cm (L) x 88.9cm (W) x 43.2cm (H)

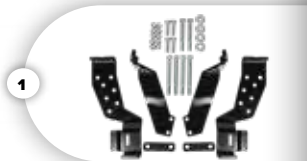

### ITEM NUMBER / UPC

RAMP8219 / 693495992167  
STOR8422 / 693495992174  
SUMM8826 / 693495992181

### FEATURES

- Fits most light trucks and SUV's
- Easy to mount – simply slides onto your custom vehicle specific mounting brackets in seconds **1**
- Slide out and roll away for storage
- A wireless winch lifts the blade, controlled from inside your warm vehicle for easy up and down snow control **2**
- Blade angles set and lock manually with a single lever lifting a pin to 3 blade locking positions: straight on, angled to the right, and angled to the left
- Powder coated all-steel with UV protected paint **3**
- Wireless remote control included with the kit **4**
- Locking castors allow easy plow attachment, removal, and roll away storage – just lower the wheels and roll the unit to wherever you want it
- ISO 9001 certified manufacturer
- 1-year limited warranty
- Ships in a single carton on a standard size pallet





### ITEM NUMBER / UPC

RAMP8219ELT / 826518005326  
 STOR8422ELT / 826518005333  
 SUMM8826ELT / 826518004916

### DESCRIPTION

DK2's line of personal snow plows just got better! The DK2 ELITE Series Snow Plow line up takes its simple yet effective design and improves on it with a wireless actuator for ultimate reliability.

DK2's ELITE Series each mount on to a vehicle specific custom mounting brackets. Each snow plow ships in a single carton complete with hardened steel cutting edge scraper, rubber snow deflector, polymer-wrapped wire rope plow markers, skid shoes, castor kit for easy storage, and a wireless electric actuator kit.

### SPECIFICATION

ITEM NUMBER	RAMPAGE II ELITE • RAMP8219ELT
BLADE DIMENSIONS	82" (W) x 19" (H) 208.3cm (W) x 48.3cm (H)
ASSEMBLED WEIGHT	265lb (120.2kg)
SHIPPING WEIGHT	280lb (127kg)
SHIPPING DIMENSIONS	43" (L) x 32" (W) x 18" (H) 109.2cm (L) x 81.3cm (W) x 45.7cm (H)
ITEM NUMBER	STORM II ELITE • STOR8422ELT
BLADE DIMENSIONS	84" (W) x 22" (H) 213.4cm (W) x 55.9cm (H)
ASSEMBLED WEIGHT	283lb (128.4kg)
SHIPPING WEIGHT	287lb (130.2kg)
SHIPPING DIMENSIONS	43" (L) x 32" (W) x 18" (H) 109.2cm (L) x 81.3cm (W) x 45.7cm (H)
ITEM NUMBER	SUMMIT II ELITE • SUMM8826ELT
BLADE DIMENSIONS	88" (W) x 26" (H) 223.5cm (W) x 66cm (H)
ASSEMBLED WEIGHT	296lb (134.3kg)
SHIPPING WEIGHT	301lb (136.5kg)
SHIPPING DIMENSIONS	46" (L) x 35" (W) x 17" (H) 116.8cm (L) x 88.9cm (W) x 43.2cm (H)



### FEATURES

- Fits most light trucks and SUV's
- Easy to mount – simply slides onto your custom vehicle specific mounting brackets in seconds **1**
- Slide out and roll away for storage
- An electric actuator lifts the blade, controlled from inside your warm vehicle for easy up and down snow control with built-in clutch, a strong chain, and uses less amperage than the winch, built with a completely sealed gearbox and housing and IP67 dust and water rated **2**
- Blade angles set and lock manually with a single lever lifting a pin to 3 blade locking positions: straight on, angled to the right, and angled to the left
- Powder coated all-steel with UV protected paint **3**
- Wireless remote control included with the kit **4**
- Flip down locking castors allow easy plow attachment, removal, and roll away storage - just lower the wheels and roll the unit to wherever you want it
- Each snow plow kit also includes a set of blade stiffeners for added strength
- ISO 9001 certified manufacturer
- 1-year limited warranty
- Ships in a single carton on a standard size pallet

# FULLY HYDRAULIC EVEREST SNOW PLOW

10



## ITEM NUMBER

EVST9022

## UPC

826518005579

## DESCRIPTION

DK2 is proud to bring you the ultimate snow plow solution in our line up - the DK2 Everest. This prosumer, fully hydraulic snow plow kit provides you the opportunity to clear your parking lot, driveway, or lane way whenever required. With our fully hydraulic system you can raise, lower, and angle the snow plow blade from inside your vehicle using our wired hand held remote. For extreme durability against the elements and rust, DK2 combines an industrial powder-coated paint finish on the blade with hot dipped galvanized hardware components to keep your plow looking new for years.

The plow itself simply clips to a DK2 custom fitted vehicle mounting system and can pretty much mount to anything that's fit to push snow.

## SPECIFICATION

<b>ITEM NUMBER</b>	<b>EVEREST - EVST9022</b>
<b>BLADE DIMENSIONS</b>	88" (W) x 22" (H) 223.5cm (W) x 55.9cm (H)
<b>ASSEMBLED WEIGHT</b>	425lb (192.8kg)
<b>SHIPPING WEIGHT</b>	450lb (204.1kg)
<b>SHIPPING DIMENSIONS</b>	48" (L) x 42" (W) x 40" (H) 121.9cm (L) x 106.7cm (W) x 101.6cm (H)
<b>CONSTRUCTION</b>	Steel tube and sheet
<b>COLOR/FINISH</b>	Black industrial powder-coated blade skin and all other components
<b>LIFT SYSTEM</b>	Hydraulic
<b>ANGLING SYSTEM</b>	Hydraulic, multiple positions
<b>CONTROL SYSTEM</b>	Wired remote control to lift, lower and angle left or right
<b>VEHICLE MOUNTING SYSTEM</b>	Custom bolt-on mounting brackets <b>*Sold separately</b>
<b>SCRAPER BLADE</b>	Powder-coated steel, replaceable
<b>INCLUDED</b>	Snow deflector, skid shoes



## FEATURES

- Ships partially assembled (mount & wiring required)
- Simple bolt on custom fitted mounting brackets, no drilling or welding required (sold separately) **1**
- Hydraulic system lifts and lowers blade **2**
- Light weight, no need to alter stock suspension
- Black UV powder coated components with an industrial painted blade skin **3**
- Self-leveling foot provides max blade tip clearance when the blade is fully raised
- Skid shoes to assist guiding the blade edge over uneven terrain or from possibly marking those more delicate driveways
- Snow deflector to assist directing snow forward and also minimizing windshield spray
- Wired hand held control **4**
- Blade hardware holds the hydraulic pump so it can be rolled away from the vehicle rather than being left on the truck with the mount
- Thicker trip springs to ensure tension remains strong and coils tight for optimal performance when encountering obstacles
- Existing holes in plow frame make it easy to add bolt-on accessories
- Bolt-on accessories and upgrades available

**DKA**  **POWER**



**D2M**  
  
**POWER**



## 3-INCH DISK CHIPPER SHREDDER

### ITEM NUMBER

OPC533

### UPC

827518007235

### DESCRIPTION

Don't let its size fool you. This small unit chews through any tree up to 3 inches, and demolishes branches, leaves, and garden composting using its double edge cutting blades with direct shaft drive centrifugal force, powered by a KOHLER® 2000 Series RH265 6.5HP 196cc engine.

The OPC533 also features extra large feed chutes with a heavy duty deflector, drop stand and a handy removable tow bar for compact storage, locking wheels that secure the unit in place when in use, and a quick latch chute to access the cutter chamber with ease.

### SPECIFICATION

<b>ENGINE</b>	KOHLER® 2000 Series CH265 6.5HP 196cc
<b>GEARBOX</b>	Direct drive 10.7ft/lb (14.5Nm) gross torque
<b>WHEELS &amp; TIRES</b>	ATV-locking 145/70-6 Ø13.75" (Ø34.9cm) OD x 5.25" (13.3cm)
<b>WHEELBASE</b>	26" (66cm)
<b>CHIPPING CAPACITY</b>	Ø3" (Ø7.6cm) (side feed chute) Ø3/8" (Ø0.95cm) (top-loading hopper)
<b>CUTTERS</b>	Double edge chipper blades
<b>CHIPPER SHREDDER</b>	Leaves, brush, garden compost
<b>EXPULSION CHUTE</b>	Adjustable
<b>COUPLER</b>	2" (5.08cm)
<b>DIMENSIONS</b>	63" (L) x 26" (W) x 43" (H) 160cm (L) x 66cm (W) x 109.2cm (H)
<b>WEIGHT</b>	165lb (74.8kg)
<b>SHIPPING DIMENSIONS</b>	36" (L) x 22" (W) x 25" (H) 91.4cm (L) x 55.9cm (W) x 63.9cm (H)
<b>SHIPPING WEIGHT</b>	185lb (83.9kg)
<b>WARRANTY</b>	2-year KOHLER® parts and labor 1-year DK2 chassis

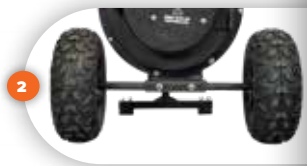

### FEATURES

- Powered by a KOHLER® 2000 Series RH265 6.5HP 196cc engine **1**
- Chips through trees up to Ø3" (Ø7.6cm) through the side feed chute and brush up to Ø3/8" (Ø0.95cm) through the top-loading hopper
- Direct drive 10.7ft/lb (14.5Nm) gross torque with 2 double edge cutters
- 145/70-6 Ø13.75" (Ø34.9cm) OD x 5.25" (13.3cm) tires on ATV-locking wheels with a 26" (66cm) wheelbase **2**
- Extra large top loading hopper for branches and leaves **3**
- Large feed chute for trees **4**
- 2" (5.08cm) coupler
- Includes 2-year KOHLER® parts and labor and 1-year DK2 chassis warranty
- **OFF-ROAD ONLY AND MAX SPEED 15MPH (24KM/H)**



## 3-INCH DISK CHIPPER SHREDDER

### ITEM NUMBER

OPC533 (NEW)

15

### UPC

827518007235



### DESCRIPTION

Don't let its size fool you. This small unit chews through any tree up to 3 inches, and demolishes twigs, leaves, and garden composting using its double edge cutting blades with direct shaft drive centrifugal force, powered by a KOHLER® 2000 Series RH265 6.5HP 196cc engine.

The OPC533 also features extra large feed chutes with a heavy duty deflector, drop stand and a handy removable tow bar for compact storage, locking wheels that secure the unit in place when in use, and a quick latch chute to access the cutter chamber with ease.

### SPECIFICATION

<b>ENGINE</b>	KOHLER® 2000 Series RH265 6.5HP 196cc
<b>GEARBOX</b>	Direct drive 10.7ft/lb (14.5Nm) gross torque
<b>WHEELS &amp; TIRES</b>	4.10/3.50-4 Ø10.2" (Ø26cm) OD x 3.9" (10cm)
<b>WHEELBASE</b>	26" (66cm)
<b>CHIPPING CAPACITY</b>	Ø3" (Ø7.6cm) (side feed chute) Ø3/8" (Ø0.95cm) (top-loading hopper)
<b>CUTTERS</b>	Double edge chipper blades
<b>CHIPPER SHREDDER</b>	Leaves, brush, garden compost
<b>EXPULSION CHUTE</b>	Adjustable
<b>COUPLER</b>	2" (5.08cm)
<b>DIMENSIONS</b>	63" (L) x 26" (W) x 43" (H) 160cm (L) x 66cm (W) x 109.2cm (H)
<b>WEIGHT</b>	165lb (74.8kg)
<b>SHIPPING DIMENSIONS</b>	36" (L) x 22" (W) x 25" (H) 91.4cm (L) x 55.9cm (W) x 63.9cm (H)
<b>SHIPPING WEIGHT</b>	185lb (83.9kg)
<b>WARRANTY</b>	2-year KOHLER® parts and labor 1-year DK2 chassis



### FEATURES

- Powered by a KOHLER® 2000 Series RH265 6.5HP 196cc engine **1**
- Chips through trees up to Ø3" (Ø7.6cm) through the side feed chute and brush up to Ø3/8" (Ø0.95cm) through the top-loading hopper
- Direct drive 10.7ft/lb (14.5Nm) gross torque with 2 double edge cutters
- 4.10/3.50-4 tires wheels with a 26" (66cm) wheelbase **2**
- Extra large top loading hopper for branches and leaves **3**
- Large feed chute for trees **4**
- 2" (5.08cm) coupler
- Includes 2-year KOHLER® parts and labor and 1-year DK2 chassis warranty
- **OFF-ROAD ONLY AND MAX SPEED 15MPH (24KM/H)**



## 3-INCH DISK CHIPPER SHREDDER

### ITEM NUMBER

OPC503

### UPC

826518005487

### FEATURES

- Powered by a KOHLER® Command PRO® CH270 7HP 208cc engine **1**
- Direct drive combo chipper shredder with double edge chip and quad hammer shredders
- Chips through trees up to Ø3" (Ø7.6cm) through the side feed chute and brush up to Ø3/8" (Ø0.95cm) through the top-loading hopper
- Extra large feed chutes **2**
- Drop stand and handy removable tow bar **3**
- 145/70-6 Ø13.75" (Ø34.9cm) OD x 5.25" (13.3cm) tires on ATV-locking wheels with a 28" (71.1cm) wheelbase **4**
- Removable key shutoff
- Includes 3-year KOHLER® engine and 1-year DK2 chassis warranty
- **OFF-ROAD ONLY AND MAX SPEED 15MPH (24KM/H)**

### DESCRIPTION

The ATV-towable 3-inch direct drive OPC503 chipper shredder is powered by a KOHLER® Command PRO® CH270 7HP 208cc engine, and comes equipped with double edge cutting blades made with high strength steel so they stay sharp longer.

Featuring direct shaft drive centrifugal force that deteriorates trees, branches, leaves, and garden composting with ease and has a 4-stage cyclonic air filter system in the KOHLER® engine, auto-blade feeding, a removable key lock shutoff, and ATV-locking off-road tires.

### SPECIFICATION

<b>ENGINE</b>	KOHLER® Command PRO® CH270 7HP 208cc
<b>GEARBOX</b>	Direct drive 10.7ft/lb (14.5Nm) gross torque
<b>WHEELS &amp; TIRES</b>	ATV-locking 145/70-6 Ø13.75" (Ø34.9cm) OD x 5.25" (13.3cm)
<b>WHEELBASE</b>	28" (71.1cm)
<b>CHIPPING CAPACITY</b>	Ø3" (Ø7.6cm) (side feed chute) Ø3/8" (Ø0.95cm) (top-loading hopper)
<b>CUTTERS</b>	Double edge chipper blades and quad hammer shredders
<b>CHIPPER SHREDDER</b>	Leaves, brush, garden compost
<b>EXPULSION CHUTE</b>	Adjustable
<b>COUPLER</b>	2" (5.08cm)
<b>DIMENSIONS</b>	71" (L) x 36.5" (W) x 48" (H) 180.3cm (L) x 92.7cm (W) x 121.9cm (H)
<b>WEIGHT</b>	187lb (84.8kg)
<b>SHIPPING DIMENSIONS</b>	43" (L) x 23" (W) x 22" (H) 109.2cm (L) x 58.4cm (W) x 55.9cm (H)
<b>SHIPPING WEIGHT</b>	199lb (90.3kg)
<b>WARRANTY</b>	3-year KOHLER® engine 1-year DK2 chassis





## 3-INCH DISK CHIPPER SHREDDER

### ITEM NUMBER

OPC513

17

### UPC

827518009123



### DESCRIPTION

The ATV-towable 3-inch direct drive OPC513 chipper shredder is powered by a KOHLER® 2000 Series RH265 6.5HP 196cc engine, and comes equipped with double edge cutting blades made with high strength steel so they stay sharp longer.

Featuring direct shaft drive centrifugal force that deteriorates trees, branches, leaves, and garden composting with ease and has a 4-stage cyclonic air filter system in the KOHLER® engine, auto-blade feeding, and 4.10/3.50-4 tires for off-road towing.

### SPECIFICATION

<b>ENGINE</b>	KOHLER® 2000 Series RH265 6.5HP 196cc
<b>GEARBOX</b>	Direct drive 10.7ft/lb (14.5Nm) gross torque
<b>WHEELS &amp; TIRES</b>	4.10/3.50-4 Ø10.2" (Ø26cm) OD x 3.9" (10cm)
<b>WHEELBASE</b>	21.7" (55cm)
<b>CHIPPING CAPACITY</b>	Ø3" (Ø7.6cm) (side feed chute) Ø3/8" (Ø0.95cm) (top-loading hopper)
<b>CUTTERS</b>	Double edge chipper blades and hammer shredders
<b>CHIPPER SHREDDER</b>	Leaves, brush, garden compost
<b>EXPULSION CHUTE</b>	Adjustable
<b>COUPLER</b>	2" (5.08cm)
<b>DIMENSIONS</b>	41.7" (L) x 34.3" (W) x 37.4" (H) 106cm (L) x 87cm (W) x 95cm (H)
<b>WEIGHT</b>	136.7lb (62kg)
<b>SHIPPING DIMENSIONS</b>	29.5" (L) x 22" (W) x 20.9" (H) 75cm (L) x 56cm (W) x 53cm (H)
<b>SHIPPING WEIGHT</b>	158.7lb (72kg)
<b>WARRANTY</b>	2-year KOHLER® engine 1-year DK2 chassis



### FEATURES

- Powered by a KOHLER® 2000 Series RH265 6.5HP 196cc engine **1**
- Direct drive combo chipper shredder with double edge chip and hammer shredders
- Perfect for trees up to 3" (7.6cm) in diameter, and twigs, leaves and garden composting up to 3/8" (0.95cm) in diameter
- Extra large feed chutes **2**
- Drop stand and handy removable tow bar **3**
- 4.10/3.50-4 Ø10.2" (Ø26cm) OD x 3.9" (10cm) tires **4**
- Includes 2-year KOHLER® engine and 1-year DK2 chassis warranty
- **OFF-ROAD ONLY AND MAX SPEED 15MPH (24KM/H)**



## 3-INCH FARM DUTY DISK CHIPPER SHREDDER

18



### ITEM NUMBER

OPC523

### UPC

XXXXXXXXXXXX

### DESCRIPTION

The ATV-towable 3-inch direct drive OPC523 farm duty chipper shredder is powered by a KOHLER® 2000 Series RH265 6.5HP 196cc engine, and comes equipped with double edge cutting blades made with high strength steel so they stay sharp longer.

Featuring direct shaft drive centrifugal force that deteriorates trees, branches, leaves, and garden composting with ease and comes with a chip bag so you don't have to worry about cleanup, auto-blade feeding, and 4.10/3.50-4 tires for off-road towing.

### FEATURES

- Powered by a KOHLER® 2000 Series RH265 6.5HP 196cc engine **1**
- Direct drive combo chipper shredder with double edge chip and hammer shredders
- Perfect for trees up to 3" (7.6cm) in diameter, and twigs, leaves and garden composting up to 3/8" (0.95cm) in diameter
- Extra large feed chutes **2**
- Drop stand and handy removable tow bar **3**
- 4.10/3.50-4 Ø10.2" (Ø26cm) OD x 3.9" (10cm) tires **4**
- Includes 2-year KOHLER® engine and 1-year DK2 chassis warranty
- **OFF-ROAD ONLY AND MAX SPEED 15MPH (24KM/H)**

### SPECIFICATION

<b>ENGINE</b>	KOHLER® 2000 Series RH265 6.5HP 196cc
<b>GEARBOX</b>	Direct drive 10.7ft/lb (14.5Nm) gross torque
<b>WHEELS &amp; TIRES</b>	4.10/3.50-4 Ø10.2" (Ø26cm) OD x 3.9" (10cm)
<b>WHEELBASE</b>	21.7" (55cm)
<b>CHIPPING CAPACITY</b>	Ø3" (Ø7.6cm) (side feed chute) Ø3/8" (Ø0.95cm) (top-loading hopper)
<b>CUTTERS</b>	Double edge chipper blades and hammer shredders
<b>CHIPPER SHREDDER</b>	Leaves, brush, garden compost
<b>EXPULSION CHUTE</b>	Adjustable
<b>COUPLER</b>	2" (5.08cm)
<b>DIMENSIONS</b>	41.7" (L) x 34.3" (W) x 37.4" (H) 106cm (L) x 87cm (W) x 95cm (H)
<b>WEIGHT</b>	136.7lb (62kg)
<b>SHIPPING DIMENSIONS</b>	29.5" (L) x 22" (W) x 20.9" (H) 75cm (L) x 56cm (W) x 53cm (H)
<b>SHIPPING WEIGHT</b>	158.7lb (72kg)
<b>WARRANTY</b>	2-year KOHLER® engine 1-year DK2 chassis



## 3-INCH DISK CHIPPER SHREDDER & VACUUM

### ITEM NUMBER

OPC503V

19

### UPC

827518006979

### DESCRIPTION

The ATV-towable 3-inch direct drive OPC503V chipper shredder vacuum combo is powered by a KOHLER® Command PRO® CH270 7HP 208cc engine, and comes equipped with double edge cutting blades made with high strength steel so they stay sharp longer.

Featuring direct shaft drive centrifugal force that deteriorates trees, branches, leaves, and garden composting with ease and has a 4-stage cyclonic air filter system in the KOHLER® engine, auto-blade feeding, a removable key lock shutoff, and ATV-locking off-road tires.

### SPECIFICATION

<b>ENGINE</b>	KOHLER® Command PRO® CH270 7HP 208cc
<b>GEARBOX</b>	Direct drive 10.7ft/lb (14.5Nm) gross torque
<b>WHEELS &amp; TIRES</b>	ATV-locking 145/70-6 Ø13.75" (Ø34.9cm) OD x 5.25" (13.3cm)
<b>WHEELBASE</b>	28" (71.1cm)
<b>CHIPPING CAPACITY</b>	Ø3" (Ø7.6cm) (side feed chute) Ø3/8" (Ø0.95cm) (top-loading hopper)
<b>CUTTERS</b>	Double edge chipper blades and quad hammer shredders
<b>CHIPPER SHREDDER</b>	Leaves, brush, garden compost
<b>EXPULSION CHUTE</b>	Adjustable
<b>COUPLER</b>	2" (5.08cm)
<b>DIMENSIONS</b>	71" (L) x 36.5" (W) x 48" (H) 180.3cm (L) x 92.7cm (W) x 121.9cm (H)
<b>WEIGHT</b>	187lb (84.8kg)
<b>SHIPPING DIMENSIONS</b>	43" (L) x 23" (W) x 22" (H) 109.2cm (L) x 58.4cm (W) x 55.9cm (H)
<b>SHIPPING WEIGHT</b>	199lb (90.3kg)
<b>WARRANTY</b>	3-year KOHLER® engine 1-year DK2 chassis



### FEATURES

- Powered by a KOHLER® Command PRO® CH270 7HP 208cc engine <sup>1</sup>
- Vacuum kit included <sup>2</sup>
- Direct drive combo chipper shredder with double edge chip and quad hammer shredders
- Chips through trees up to Ø3" (Ø7.6cm) through the side feed chute and brush up to Ø3/8" (Ø0.95cm) through the top-loading hopper
- Extra large feed chutes <sup>3</sup>
- Drop stand and handy removable tow bar <sup>4</sup>
- 145/70-6 Ø13.75" (Ø34.9cm) OD x 5.25" (13.3cm) tires on ATV-locking wheels with a 28" (71.1cm) wheelbase <sup>5</sup>
- Removable key shutoff
- Includes 3-year KOHLER® engine and 1-year DK2 chassis warranty
- **OFF-ROAD ONLY AND MAX SPEED 15MPH (24KM/H)**



## 4-INCH DISK CHIPPER

### ITEM NUMBER

OPC514

### UPC

827518007266

20



### DESCRIPTION

Introducing the OPC514 4-inch disk chipper, powered by a KOHLER® Command PRO® CH440 14HP 429cc engine that gives you the power to devour trees and branches up to 4.5 inches in diameter.

This unit's expulsion chute is perfect for pickup truck bed height, and its dual-belt drive disk chipping capability keeps the chipper more compact than other comparable models.

The OPC514 is also D.O.T. approved and should be towed at a maximum of 25 MPH with the included 2" hitch receiver, tow bar and free jack, this unit can be moved to different locations with ease.

### SPECIFICATION

<b>ENGINE</b>	KOHLER® Command PRO® CH440 14HP 429cc
<b>GEARBOX</b>	Direct drive 22.7ft/lb (14.5Nm) gross torque
<b>WHEELS &amp; TIRES</b>	D.O.T. approved 4.80-8 Ø16.1" (Ø40.9cm) OD x 3.75" (9.5cm)
<b>CHIPPING CAPACITY</b>	Ø4.5" (Ø11.4cm)
<b>CUTTER DISK</b>	Dual-belt drive 0.67" (1.7cm) x Ø35.4" (Ø90cm) centrifugal clutch
<b>SELF-FEEDING</b>	Auto blade feeding
<b>EXPULSION CHUTE</b>	Adjustable
<b>COUPLER</b>	2" (5.08cm)
<b>DIMENSIONS</b>	89.4" (L) x 39.4" (W) x 65.2" (H) 227.1cm (L) x 100.1cm (W) x 165.6cm (H)
<b>WEIGHT</b>	573lb (259.9kg)
<b>SHIPPING DIMENSIONS</b>	41.4" (L) x 30.4" (W) x 49.3" (H) 105.2cm (L) x 77.2cm (W) x 125.2cm (H)
<b>SHIPPING WEIGHT</b>	595lb (269.9kg)
<b>WARRANTY</b>	3-year KOHLER® engine 1-year DK2 chassis



### FEATURES

- Powered by a KOHLER® Command PRO® CH440 14HP 429cc engine **1**
- Chips through trees and branches up to 4.5" (11.4cm) in diameter.
- Built with dual-belt drive 0.67" (1.7cm) x Ø35.4" (Ø90cm) centrifugal clutch disk **2**
- Tow bar and jack included **3**
- D.O.T. approved 4.80-8 Ø16.1" (Ø40.9cm) tires to move the unit to different job sites easily
- Designed to be pickup truck bed height for effortless chip loading
- Tool-free disk chamber access
- Includes 3-year KOHLER® engine and 1-year DK2 chassis warranty
- **NOT HIGHWAY TOWABLE AND MAX SPEED 25MPH (40KM/H)**



## 4-INCH KINETIC DRUM CHIPPER

### ITEM NUMBER

OPC524

21

### UPC

827518007259

### DESCRIPTION

The OPC524 4-inch kinetic chipper is powered by a KOHLER® Command PRO® CH270 7HP 208cc engine and features dual swing chutes, double edge reversible high-speed cutting blades, bearing-mounted ATV tires and rims and built in toolbox with an extended load chute with safety e-stop.

The engine delivers 10.5ft/lb torque for superior cutting performance, and the dual V-belt direct drive and kinetic cyclonic drum pulverize up to 4-inch diameter trees. The tool-free dual swing chutes quickly open for easy drum access. The feed chute features dual integrated handles for easy equipment moving, and finally this machine comes equipped with a quick-drop stand, and a 1-7/8 inch ball removable tow bar to move around job sites with ease.

### SPECIFICATION

<b>ENGINE</b>	KOHLER® Command PRO® CH270 7HP 208cc
<b>GEARBOX</b>	Direct drive 10.7ft/lb (14.5Nm) gross torque
<b>WHEELS &amp; TIRES</b>	175/70-6 Ø13.5" (Ø34.3cm) OD x 5" (12.7cm) tires on Ø6" (15.2cm) x 4.5" (11.4cm) bearing-mounted ATV rims
<b>CHIPPING CAPACITY</b>	Ø4" (Ø10.16cm)
<b>CUTTERS</b>	Double edge reversible chipper blades
<b>CHIPPER</b>	Auto-adjusting up to Ø4" (Ø10.16cm) trees and brush
<b>EXPULSION CHUTE</b>	Tool-free swing open and 180° adjustable
<b>COUPLER</b>	1-7/8" (4.76cm)
<b>DIMENSIONS</b>	91" (L) x 30" (W) x 46" (H) 231.1cm (L) x 76.2cm (W) x 116.8cm (H)
<b>WEIGHT</b>	300lb (136.1kg)
<b>SHIPPING DIMENSIONS</b>	34" (L) x 22" (W) x 35" (H) 86.4cm (L) x 55.9cm (W) x 88.9cm (H)
<b>SHIPPING WEIGHT</b>	330lb (149.7kg)
<b>WARRANTY</b>	3-year KOHLER® engine 1-year DK2 chassis



### FEATURES

- Powered by a KOHLER® Command PRO® CH270 7HP 208cc engine **1**
- Chips through trees and branches up to 4" (10.2cm) in diameter
- Dual-belt drive drum transmission with double edge reversible cutting blades for trees and brush up to 4" (10.2cm) in diameter **2**
- 175/70-6 Ø13.5" (Ø34.3cm) OD x 5" (12.7cm) tires on Ø6" (Ø15.2cm) x 4.5" (11.4cm) bearing-mounted ATV rims for off-road performance **3**
- Extra-large extended feed chute with integrated equipment moving handles and E-stop safety shutoff **4**
- Dual tool-free swing open chutes for easy drum access
- 180° tool-free rotational spout on expulsion chute
- Removable tow bar with 1-7/8" (4.76cm) hitch receiver
- Includes 3-year KOHLER® engine and 1-year DK2 chassis warranty
- **OFF-ROAD ONLY AND MAX SPEED 15MPH (24KM/H)**



## 5-INCH KINETIC DRUM CHIPPER

22



### ITEM NUMBER

OPC525

### UPC

827518008560

### DESCRIPTION

The OPC525 5-inch kinetic chipper is powered by a KOHLER® Command PRO® CH395 9.5HP 277cc engine and features dual swing chutes, double edge reversible high-speed cutting blades, bearing-mounted ATV tires and rims and built in toolbox with an extended load chute with safety e-stop.

The engine delivers 13.9ft/lb torque for superior cutting performance, and the dual V-belt direct drive and kinetic cyclonic drum pulverize up to 5-inch diameter trees. The tool-free dual swing chutes quickly open for easy drum access. The feed chute features dual integrated handles for easy equipment moving, and finally this machine comes equipped with a quick-drop stand, and a 1-7/8 inch ball removable tow bar to move around job sites with ease.

### SPECIFICATION

<b>ENGINE</b>	KOHLER® Command PRO® CH395 9.5HP 277cc
<b>GEARBOX</b>	Direct drive 13.9ft/lb (18.8Nm) gross torque
<b>WHEELS &amp; TIRES</b>	175/70-6 Ø13.5" (Ø34.3cm) OD x 5" (12.7cm) tires on Ø6" (15.2cm) x 4.5" (11.4cm) bearing-mounted ATV rims
<b>CHIPPING CAPACITY</b>	Ø5" (Ø12.7cm)
<b>CUTTERS</b>	Double edge reversible chipper blades
<b>CHIPPER</b>	Auto-adjusting up to Ø5" (Ø12.7cm) trees and brush
<b>EXPULSION CHUTE</b>	Tool-free swing open and 180° adjustable
<b>COUPLER</b>	1-7/8" (4.76cm)
<b>DIMENSIONS</b>	91" (L) x 30" (W) x 46" (H) 231.1cm (L) x 76.2cm (W) x 116.8cm (H)
<b>WEIGHT</b>	308.6lb (140kg)
<b>SHIPPING DIMENSIONS</b>	35.8" (L) x 22" (W) x 37.8" (H) 91cm (L) x 56cm (W) x 96cm (H)
<b>SHIPPING WEIGHT</b>	352.7lb (160kg)
<b>WARRANTY</b>	3-year KOHLER® engine 1-year DK2 chassis



### FEATURES

- Powered by a KOHLER® Command PRO® CH395 9.5HP 277cc engine **1**
- Chips through trees and branches up to 5" (12.7cm) in diameter
- Dual-belt drive drum transmission with double edge reversible cutting blades for trees and brush up to 5" (12.7cm) in diameter **2**
- 175/70-6 Ø13.5" (Ø34.3cm) OD x 5" (12.7cm) tires on Ø6" (Ø15.2cm) x 4.5" (11.4cm) bearing-mounted ATV rims for off-road performance **3**
- Extra-large extended feed chute with integrated equipment moving handles and E-stop safety shutoff **4**
- Dual tool-free swing open chutes for easy drum access
- 180° tool-free rotational spout on expulsion chute
- Removable tow bar with 1-7/8" (4.76cm) hitch receiver
- Includes 3-year KOHLER® engine and 1-year DK2 chassis warranty
- **OFF-ROAD ONLY AND MAX SPEED 15MPH (24KM/H)**



### ITEM NUMBER

OPC505AE

23

### UPC

827518006702



### DESCRIPTION

Powered by a KOHLER® Command PRO® CH440 14HP 429cc engine featuring electric start-up and a self contained auto-feed system with hydraulic roller speeds up to 600RPM. The OPC505AE features a 3600RPM drive and auto-adjusting feed chamber to demolish trees up to 5.25 inches in diameter, internal free-spinning teeth, large feed chute, adjustable pickup height rotational expulsion chute, tool-free 180° adjustable 61-inch chip chute perfect for pickup truck bed loading, and includes a set of lockout keys, safety glasses, ear protection, work gloves, oil bottle and assembly tools.

### SPECIFICATION

ENGINE	KOHLER® Command PRO® CH440 14HP 429cc
GEARBOX	Direct drive 22.7ft/lb (30.7Nm) gross torque
WHEELS & TIRES	D.O.T. approved 8.00-7 Ø16" (Ø40.6cm) OD
WHEELBASE	47" (119.4cm)
CHIPPING CAPACITY	Ø5.25" (Ø13.3cm)
BLADES & TEETH	High-speed disk-mounted steel and free-spinning internal 45# steel teeth
CHIPPER SHREDDER	Auto-adjusting from Ø1/8" (Ø0.32cm) brush to Ø5.25" (Ø13.3cm) trees
SELF-FEEDING	Auto blade feeding hydraulic system
EXPULSION CHUTE	Truck bed height with 180° adjustable spout
COUPLER	2" (5.08cm)
DIMENSIONS	91" (L) x 40" (W) x 69" (H) 231.1cm (L) x 101.6cm (W) x 175.3cm (H)
WEIGHT	638lb (289.4kg)
SHIPPING DIMENSIONS	63" (L) x 33" (W) x 45" (H) 160cm (L) x 83.8cm (W) x 114.3cm (H)
SHIPPING WEIGHT	726lb (329.3kg)
WARRANTY	3-year KOHLER® engine 1-year DK2 chassis



### FEATURES

- Powered by a KOHLER® Command PRO® CH440 14HP 429cc engine <sup>1</sup>
- Dual swing-open chutes for easy drum access
- High-speed disk chipper shredder with free-spinning internal teeth <sup>2</sup>
- 600RPM hydraulic feed
- Auto blade feeding system
- Auto adjust cutters for brush up to 5.25" (13.3cm) diameter trees
- All-terrain on/off road tires D.O.T. approved (not for highway use) with included 2" (5.08cm) ball tow bar <sup>3</sup>
- Dual, tool free rotational spout on chip chute
- Extra-large reinforced feed hopper with integrated equipment moving handles and e-stop shutoff <sup>4</sup>
- Electric start (battery included)
- Includes 3-year KOHLER® engine and 1-year DK2 chassis warranty
- **NOT HIGHWAY TOWABLE AND MAX SPEED 25MPH (40KM/H)**



## 6-INCH CYCLONIC DRUM CHIPPER SHREDDER

24



### ITEM NUMBER

OPC506

### UPC

826518005517

### DESCRIPTION

The DK2 POWER OPC506 is a 6-inch cyclonic chipper shredder is powered by a KOHLER® Command PRO® CH440 14HP 429cc engine, equipped with dual 13-inch, double-edge reversible cutting blades that auto-adjust to pulverize trees and brush up to 6.25 inches in diameter.

Featuring large quick open hoppers, 59-inch truck bed height chip chute with adjustable cast iron rotating hood, easy drop stand, removable tow bar, 2-inch hitch, premium built-in tool box, Key shutoff with lock out safety switch. Extended 48-inch safety stability axle with D.O.T. tires. Safety kit includes tools, glasses, ear protection and gloves.

### SPECIFICATION

**ENGINE** KOHLER® Command PRO® CH440 14HP 429cc

**GEARBOX** Dual direct drive 22.7ft/lb (30.7Nm) gross torque

**WHEELS & TIRES** D.O.T. approved 4.80-8 Ø17.5" (Ø44.5cm) OD x 5.2" (13.2cm)

**CHIPPING CAPACITY** Ø6.25" (Ø15.9cm)

**BLADES** Steel double edge reversible

**CHIPPER SHREDDER** Auto-adjusting from Ø3/8" (Ø0.95cm) brush to Ø6.5" (Ø16.5cm) trees

**EXPULSION CHUTE** Tool-free swing open and 180° adjustable

**COUPLER** 2" (5.08cm)

**DIMENSIONS** 102" (L) x 47" (W) x 59" (H)  
259.1cm (L) x 119.4cm (W) x 149.9cm (H)

**WEIGHT** 395lb (179.2kg)

**SHIPPING DIMENSIONS** 44" (L) x 26" (W) x 44" (H)  
111.8cm (L) x 66cm (W) x 111.8cm (H)

**SHIPPING WEIGHT** 461lb (209.1kg)

**WARRANTY** 3-year KOHLER® engine  
1-year DK2 chassis



### FEATURES

- Powered by a KOHLER® Command PRO® CH440 14HP 429cc engine **1**
- Reversible double-edge reversible high-speed cutting blades **2**
- Auto-adjusting cyclonic drum chamber deteriorates trees and brush up to 6.25" (15.9cm) in diameter
- Large, quick-open hoppers
- 59" (149.9cm) pickup truck bed height expulsion chute with adjustable cast iron rotating hood and easy drop stand **3**
- Removable tow bar with 2" (5.08cm) hitch receiver **4**
- Premium built-in toolbox
- Key shutoff with lock out safety switch
- Extended 48" (121.9cm) safety stability axle
- D.O.T. approved 4.80-8 Ø17.5" (Ø44.5cm) OD x 5.2" (13.2cm) **5**
- Safety kit includes tools, glasses, ear protection and gloves
- Integrated chute handles, powder-coated for durability
- Includes 3-year KOHLER® engine and 1-year DK2 chassis warranty
- **NOT HIGHWAY TOWABLE AND MAX SPEED 25MPH (40KM/H)**







ITEM NUMBER  
XXXXXXX **25**

ITEM NUMBER

XXXXXXX

UPC

XXXXXXXXXXXX

### DESCRIPTION

This DK2 POWER addition is a 6-inch cyclonic chipper shredder is powered by a KOHLER® Command PRO® CH440 14HP 429cc engine that features easy-pull recoil start technology, and comes equipped with dual 13-inch, double-edge reversible cutting blades that auto-adjust to pulverize trees and brush up to 6.25 inches in diameter.

Additional features include large quick open hoppers, 59-inch truck bed height chip chute with adjustable cast iron rotating hood, easy drop stand, removable tow bar, 2-inch hitch, premium built-in tool box, Key shutoff with lock out safety switch. Extended 48-inch safety stability axle with D.O.T. tires. Safety kit includes tools, glasses, ear protection and gloves.

### SPECIFICATION

ENGINE	KOHLER® Command PRO® CH440 14HP 429cc
GEARBOX	Dual direct drive 22.7ft/lb (30.7Nm) gross torque
WHEELS & TIRES	D.O.T. approved 4.80-8 Ø17.5" (Ø44.5cm) OD x 5.2" (13.2cm)
CHIPPING CAPACITY	Ø6.25" (Ø15.9cm)
BLADES	Steel double edge reversible
CHIPPER SHREDDER	Auto-adjusting from Ø3/8" (Ø0.95cm) brush to Ø6.5" (Ø16.5cm) trees
EXPULSION CHUTE	Tool-free swing open and 180° adjustable
COUPLER	2" (5.08cm)
DIMENSIONS	102" (L) x 47" (W) x 59" (H) 259.1cm (L) x 119.4cm (W) x 149.9cm (H)
WEIGHT	395lb (179.2kg)
SHIPPING DIMENSIONS	44" (L) x 26" (W) x 44" (H) 111.8cm (L) x 66cm (W) x 111.8cm (H)
SHIPPING WEIGHT	461lb (209.1kg)
WARRANTY	3-year KOHLER® engine 1-year DK2 chassis



### FEATURES

- Powered by a KOHLER® Command PRO® CH440 14HP 429cc engine **1**
- Easy-pull recoil start technology
- Reversible double-edge reversible high-speed cutting blades **2**
- Auto-adjusting cyclonic drum chamber deteriorates trees and brush up to 6.25" (15.9cm) in diameter
- Large, quick-open hoppers
- 59" (149.9cm) pickup truck bed height expulsion chute with adjustable cast iron rotating hood and easy drop stand **3**
- Removable tow bar with 2" (5.08cm) hitch receiver **4**
- Premium built-in toolbox
- Key shutoff with lock out safety switch
- Extended 48" (121.9cm) safety stability axle
- D.O.T. approved 4.80-8 Ø17.5" (Ø44.5cm) OD x 5.2" (13.2cm) **5**
- Safety kit includes tools, glasses, ear protection and gloves
- Integrated chute handles, powder-coated for durability
- Includes 3-year KOHLER® engine and 1-year DK2 chassis warranty
- **NOT HIGHWAY TOWABLE AND MAX SPEED 25MPH (40KM/H)**



## 6-INCH KINETIC CYCLONIC ELECTRIC START DRUM CHIPPER SHREDDER

### ITEM NUMBER

OPC566E

### UPC

827518006757

26



### DESCRIPTION

The OPC566E is a 6-inch kinetic cyclonic chipper powered by an electric start, direct drive KOHLER® Command PRO® CH440 14HP 429cc engine with 22.7ft/lb gross torque to demolish trees up to 6.25 inches in diameter. Equipped with double edge reversible 12-inch cutting blades that auto-adjust to pulverize trees and brush, dual tool-free swing-open chutes that quickly open for easy drum access, D.O.T. approved tires and a 48-inch extended axle for uneven ground and towing stability with front articulated ground wheels for easy equipment moving, a 2-inch hitch receiver and tow bar, and a rotational expulsion chute pickup truck height for bed loading.

### SPECIFICATION

<b>ENGINE</b>	KOHLER® Command PRO® CH440 14HP 429cc
<b>GEARBOX</b>	Direct drive 22.7ft/lb (30.7Nm) gross torque
<b>REAR WHEELS &amp; TIRES</b>	D.O.T. approved 4.80-8 Ø15" (Ø41.9cm) OD x 4.25" (10.8cm) on 9" (22.9cm) rims
<b>FRONT WHEELS &amp; TIRES</b>	Off-road 4.10-4 Ø10" (Ø25.4cm) OD on Ø5" (Ø12.7cm) rims
<b>WHEELBASE</b>	48" (121.9cm)
<b>CHIPPING CAPACITY</b>	Ø6.25" (Ø15.9cm)
<b>CUTTERS</b>	12" (30.5cm) double edge reversible chipper blades
<b>CHIPPER SHREDDER</b>	Auto-adjusting from Ø1/8" (Ø0.32cm) up to Ø6.25" (Ø15.9cm) trees and brush
<b>EXPULSION CHUTE</b>	59" (149.9cm) truck bed height with 180° adjustable spout
<b>COUPLER</b>	2" (5.08cm)
<b>DIMENSIONS</b>	102" (L) x 47" (W) x 59" (H) 259.1cm (L) x 119.4cm (W) x 149.9cm (H)
<b>WEIGHT</b>	594lb (269.4kg)
<b>SHIPPING DIMENSIONS</b>	45" (L) x 31" (W) x 48" (H) 114.3cm (L) x 78.7cm (W) x 121.9cm (H)
<b>SHIPPING WEIGHT</b>	726lb (329.3kg)
<b>WARRANTY</b>	3-year KOHLER® engine 1-year DK2 chassis



### FEATURES

- Powered by a KOHLER® Command PRO® CH440 14HP 429cc engine **1**
- Dual-belt drive drum transmission with 12" (30.5cm) double edge reversible cutting blades **2**
- Auto adjust cutters for trees and brush up to 6.25" (15.9cm) in diameter
- Extended 48" (121.9cm) axle with D.O.T. approved 4.80-8 Ø15" (Ø41.9cm) OD rear tires on Ø9" (Ø22.9cm) rims and off-road 4.10-4 Ø10" (Ø25.4cm) OD front tires on Ø5" (Ø12.7cm) rims **3**
- Includes safety glasses, ear protection, work gloves and assembly tools
- Electric start (battery included) **4**
- CE safety approved shutoff
- Dual tool free swing open chutes
- Tool-free 180° rotational spout on 59" (149.9cm) truck bed height expulsion chute
- Extra-large feed chute with integrated equipment moving handles
- Includes 3-year KOHLER® engine and 1-year DK2 chassis warranty
- **NOT HIGHWAY TOWABLE AND MAX SPEED 25MPH (40KM/H)**



## 12-INCH STUMP GRINDER

### ITEM NUMBERS

OPG777

27

### UPC

826518005524



### DESCRIPTION

Introducing the OPG777 12-inch stump grinder powered by a KOHLER® Command PRO® CH440 14HP 429cc engine and mounted on a heavy-duty welded 2-inch solid steel frame structurally engineered for endurance performance with a heavy-duty 2-inch axle and dual locking hitch pins for trouble-free wheel brakes and transport over rough terrain. The direct drive delivers 3600RPM and 22.7 ft/lb of gross torque to a 12-inch solid steel cutting wheel mounted on premium pillar bearings. This machine demolishes stumps with a total of 9 carbide teeth cutting 3-1/2 inches wide per cut and cuts any diameter stump 12-inches above and 9-inches below ground. Additional features include key shut-off, locking throttle, drop stand, and solid bar lift handles.

### SPECIFICATION

ENGINE	KOHLER® Command PRO® CH440 14HP 429cc
GEARBOX	Dual-belt direct drive 22.7ft/lb (30.7Nm) gross torque
WHEELS & TIRES	ATV-locking 145/70-6 Ø13.75" (Ø34.9cm) OD x 5.25" (13.3cm)
WHEELBASE	32" (81.3cm)
TEETH	9 x FC11C carbide cast mounted
STUMP CAPACITY	Any diameter, 12" (30.5cm) high
CUTTING WIDTH	3.5" (8.9cm)
COUPLER	2" (5.08cm)
DIMENSIONS	91" (L) x 32" (W) x 52" (H) 231.1cm (L) x 81.3cm (W) x 132.1cm (H)
WEIGHT	234lb (106.1kg)
SHIPPING DIMENSIONS	43" (L) x 23" (W) x 25" (H) 109.2cm (L) x 58.4cm (W) x 63.5cm (H)
SHIPPING WEIGHT	275lb (124.7kg)
WARRANTY	3-year KOHLER® engine 1-year DK2 chassis



### FEATURES

- Powered by a KOHLER® Command PRO® CH440 14HP 429cc engine **1**
- Demolishes stumps with 9 carbide teeth cutting 3.5" (8.9cm) wide per cut. **2**
- Cuts any diameter stump 12" (30.5cm) above and 9" (22.9cm) below ground.
- Extreme duty 2" (5.08cm) x 2" (5.08cm) axle with dual locking hitch pins for trouble-free wheel brakes and transport over rough terrain
- 145/70-6 Ø13.75" (Ø34.9cm) OD x 5.25" (13.3cm) tires on ATV-locking wheels **3**
- Key shut-off
- Locking throttle
- Drop stand and removable tow bar **4**
- Solid bar lift handles
- Includes 3-year KOHLER® engine and 1-year DK2 chassis warranty
- **OFF-ROAD ONLY AND MAX SPEED 15MPH (24KM/H)**



## 12-INCH ELECTRIC START STUMP GRINDER

28



### ITEM NUMBERS

OPG777E

### UPC

XXXXXXXXXXXX

### DESCRIPTION

Introducing the OPG777E 12-inch stump grinder powered by a KOHLER® Command PRO® CH440 14HP 429cc engine and mounted on a heavy-duty welded 2-inch solid steel frame structurally engineered for endurance performance with a heavy-duty 2-inch axle and dual locking hitch pins for trouble-free wheel brakes and transport over rough terrain. The direct drive delivers 3600RPM and 22.7 ft/lb of gross torque to a 12-inch solid steel cutting wheel mounted on premium pillar bearings. This machine demolishes stumps with a total of 9 carbide teeth cutting 3-1/2 inches wide per cut and cuts any diameter stump 12-inches above and 9-inches below ground. Additional features include key shut-off, locking throttle, drop stand, and solid bar lift handles.

### SPECIFICATION

ENGINE	KOHLER® Command PRO® CH440 14HP 429cc
GEARBOX	Dual-belt direct drive 22.7ft/lb (30.7Nm) gross torque
WHEELS & TIRES	ATV-locking 145/70-6 Ø13.75" (Ø34.9cm) OD x 5.25" (13.3cm)
WHEELBASE	32" (81.3cm)
TEETH	9 x FC11C carbide cast mounted
STUMP CAPACITY	Any diameter, 12" (30.5cm) high
CUTTING WIDTH	3.5" (8.9cm)
BATTERY	12V 14Ah
COUPLER	2" (5.08cm)
DIMENSIONS	91" (L) x 32" (W) x 52" (H) 231.1cm (L) x 81.3cm (W) x 132.1cm (H)
WEIGHT	234lb (106.1kg)
SHIPPING DIMENSIONS	43" (L) x 23" (W) x 25" (H) 109.2cm (L) x 58.4cm (W) x 63.5cm (H)
SHIPPING WEIGHT	275lb (124.7kg)
WARRANTY	3-year KOHLER® engine 1-year DK2 chassis



### FEATURES

- Powered by a KOHLER® Command PRO® CH440 14HP 429cc engine **1**
- Demolishes stumps with 9 carbide teeth cutting 3.5" (8.9cm) wide per cut. **2**
- Cuts any diameter stump 12" (30.5cm) above and 9" (22.9cm) below ground.
- Extreme duty 2" (5.08cm) x 2" (5.08cm) axle with dual locking hitch pins for trouble-free wheel brakes and transport over rough terrain
- 145/70-6 Ø13.75" (Ø34.9cm) OD x 5.25" (13.3cm) tires on ATV-locking wheels **3**
- Key shut-off
- Locking throttle
- Drop stand and removable tow bar **4**
- Solid bar lift handles
- 12V 14Ah battery included for electric start capability
- Includes 3-year KOHLER® engine and 1-year DK2 chassis warranty
- **OFF-ROAD ONLY AND MAX SPEED 15MPH (24KM/H)**



## 14-INCH ELECTRIC START STUMP GRINDER

### ITEM NUMBER

OPG888E

29

### UPC

827518006719

### DESCRIPTION

Introducing the OPG888E, powered by a KOHLER® Command PRO® CH440 14HP 429cc engine with electric start, and is capable of demolishing stumps 14 inches above ground and 10 inches below ground with its dual V-belt direct drive 22.7ft/lb gross torque and 12 FC11C carbide cast mounted teeth that cut 4 inches wide. This machine features a heavy-duty frame, 145/70-6 ATV tires, a removable flip tow bar for easy trolley or off-road towing up to 15mph (24km/h), an operator controlled posi-lock wheel brake for pivot grinding, and a bow handle with CE safety approved hands-off shut down.

### SPECIFICATION

<b>ENGINE</b>	KOHLER® Command PRO® CH440 14HP 429cc
<b>GEARBOX</b>	Dual V-belt direct drive 22.7ft/lb (30.7Nm) gross torque
<b>WHEELS &amp; TIRES</b>	ATV 145/70-6 Ø13.75" (Ø35cm) x 5.25" (13.3cm)
<b>WHEELBASE</b>	32" (81.3cm)
<b>TEETH</b>	12 x FC11C carbide cast mounted
<b>STUMP CAPACITY</b>	Any diameter, 14" (35.6cm) high
<b>CUTTING WIDTH</b>	4" (10.2cm)
<b>BATTERY</b>	12V 14Ah
<b>COUPLER</b>	2" (5.08cm)
<b>DIMENSIONS</b>	102" (L) x 48" (W) x 59" (H) 259.1cm (L) x 121.9cm (W) x 149.9cm (H)
<b>WEIGHT</b>	285lb (129.3kg)
<b>SHIPPING DIMENSIONS</b>	42" (L) x 31" (W) x 26" (H) 106.7cm (L) x 78.7cm (W) x 66cm (H)
<b>SHIPPING WEIGHT</b>	308lb (139.7kg)
<b>WARRANTY</b>	3-year KOHLER® engine 1-year DK2 chassis



### FEATURES

- Powered by a KOHLER® Command PRO® CH440 14HP 429cc engine **1**
- Performs 4" (10.2cm) wide cuts with 12 FC11C carbide cast mounted teeth **2**
- Heavy-duty steel frame
- ATV 145/70-6 Ø13.75" (Ø35cm) x 5.25" (13.3cm) tires on a 32" (81.3cm) wheelbase **3**
- Removable flip tow bar with a 2" (5.08cm) hitch receiver **4**
- Operator controlled Posi-lock wheel brake for pivot grinding
- Bow handle with CE safety approved hands-off shut-down **5**
- Demolishes any diameter stump up to 14" (35.6cm) above and 10" (25.4cm) below ground
- 12V 14Ah battery included for electric start capability
- Includes 3-year KOHLER® engine and 1-year DK2 chassis warranty
- **OFF-ROAD ONLY AND MAX SPEED 15MPH (24KM/H)**



## 18-INCH TRENCHER

### ITEM NUMBERS

OPT118

### UPC

826518005586

### FEATURES

- Powered by a KOHLER® Command PRO® CH270 7HP 208cc engine **1**
- Direct chain drive trencher chain and auger
- 5 depth positions
- Auto-locking in reverse 6.00-6 Ø15" (Ø38.1cm) OD tires and wheels for digging in reverse **2**
- 3/8" (0.95cm) plow plates with 21 carbide alloy high-pressure quick change teeth **3**
- Adjustable handle with release and stop safety hand grip **4**
- 6" (15.2cm) direct drive auger
- Heavy gauge steel construction
- Direct drive with 400RPM tri-cut teeth chain drive at 180ft/min (54.9m/min) dig rate
- Includes 3-year KOHLER® engine and 1-year DK2 chassis warranty

### DESCRIPTION

The OPT118 is powered by a KOHLER® Command PRO® CH270 7HP 208cc engine equipped with a direct drive chain trencher that travels at 180ft/min to create 18-inch deep by 4-inch wide channels using its 3/8-inch plow plates and 21 quick-change carbide alloy high-pressure tri-cut teeth that run at 400RPM, and to ensure a cleaner operation, the OPT118 is equipped with a 6-inch side off-loading auger that removes dirt from the channel.

This machine also features a heavy-duty steel construction, adjustable handle with a release and stop safety hand grip, and 15-inch 6.00-6 wheels with auto-lock in reverse capability.

### SPECIFICATION

<b>ENGINE</b>	KOHLER® Command PRO® CH270 7HP 208cc
<b>GEARBOX</b>	Direct chain drive 10.7ft/lb (14.5Nm) gross torque
<b>WHEELS &amp; TIRES</b>	6.00-6 Ø15" (Ø38.1cm) OD auto-lock in reverse
<b>CHAIN SPEED</b>	180ft/min (54.9 m/min)
<b>CHAIN DIMENSION</b>	63" (160cm)
<b>TRENCH SIZE</b>	4" (W) x 18" (D) 10.2cm (W) x 45.7cm (D)
<b>TEETH</b>	21 x carbide alloy high-pressure
<b>AUGER</b>	6" (15.2cm) side off-load
<b>DIMENSIONS</b>	95" (L) x 47" (W) x 59" (H) 241.3cm (L) x 119.4cm (W) x 149.9cm (H)
<b>WEIGHT</b>	335lb (152kg)
<b>SHIPPING DIMENSIONS</b>	41" (L) x 30" (W) x 33" (H) 104.1cm (L) x 76.2cm (W) x 83.8cm (H)
<b>SHIPPING WEIGHT</b>	362lb (164.2kg)
<b>WARRANTY</b>	3-year KOHLER® engine 1-year DK2 chassis





### ITEM NUMBER

OPS227

### UPC

827518008577

### DESCRIPTION

Introducing the 27-ton horizontal and vertical hydraulic log splitter. The DK2 POWER OPS227 is driven by a powerful KOHLER® SH265 6.5HP 196cc engine. This machine is capable of splitting up to 25.5 inches in length and 19.6 inches in diameter with uncompromising force at a cycle speed of 13 seconds, all while using the full potential of its 8-inch heat-treated steel wedge. The OPS227 sits on a 37-inch wheelbase equipped with 16-inch O.D. 4.8-8 tires and includes a tow bar for easy job site moving.

### SPECIFICATION

ENGINE	KOHLER® SH265 6.5HP 196cc
SPLITTING CAPACITY	25.5" (L) x Ø19.6" 64.7cm (L) x Ø54.8cm
CYCLE TIME	13 seconds
HYDRAULIC CYLINDER	Ø4" (Ø10.2cm) x 24" (60.9cm) stroke
HYDRAULIC FLOW RATE	15GPM (56.8LPM), two-stage
HYDRAULIC OIL CAPACITY	6.5gal (24.6L)
TYPE OF HYDRAULIC OIL	AW32/AW46
HYDRAULIC OIL FILTER	10 micron (1250 mesh) paper with NBR (Buna-N) seals
WEDGE	8" (20.3cm) high, heat-treated steel
BEAM	8" (20.3cm) foot plate
VALVE	Auto-retract with adjustable detent
WHEELS & TIRES	D.O.T. approved 4.80-8 Ø16" (Ø40.6cm) OD
WHEELBASE	37" (94cm)
COUPLER	2" (5.08cm) ball with safety chains
ASSEMBLED DIMENSIONS & WEIGHT	87.4" (L) x 49.2" (W) x 35.8" (H) @ 507lb 222cm (L) x 125cm (W) x 91cm (H) @ 230kg
SHIPPING DIMENSIONS & WEIGHT	70.9" (L) x 31.5" (W) x 19.7" (H) @ 551.2lb 180cm (L) x 80cm (W) x 50cm (H) @ 250kg
WARRANTY	2-year KOHLER® parts and labor 1-year DK2 chassis



### FEATURES

- Powered by a KOHLER® SH265 6.5HP 196cc engine **1**
- 25.5" x Ø19.6" (64.8cm x Ø49.8cm) log capacity
- 8" (20.3cm) heat-treated steel wedge **2**
- 13-second cycling time
- D.O.T. approved Ø16" (Ø40.6cm) OD road tires sitting on a 37" (94cm) wheelbase **3**
- Folds 90° for both horizontal and vertical log splitting capability **4**
- Two-stage 15GPM (56.8LPM) pump
- 6.5 gallon (24.6 litres) hydraulic fluid capacity
- Auto-retracting adjustable detent valve
- 2" (5.08cm) ball coupler with safety chains **5**
- Includes 2-year KOHLER® engine parts and labor and 1-year DK2 chassis warranty
- **NOT HIGHWAY TOWABLE AND MAX SPEED 25MPH (40KM/H)**



## 32-TON HORIZONTAL & VERTICAL HYDRAULIC LOG SPLITTER

32

### ITEM NUMBER

OPS232

### UPC

827518008584

### DESCRIPTION

Introducing the 32-ton horizontal and vertical hydraulic log splitter. The DK2 POWER OPS232 is driven by a powerful KOHLER® SH265 6.5HP 196cc engine. This machine is capable of splitting up to 25.5 inches in length and 21.6 inches in diameter with uncompromising force at a cycle speed of 13 seconds, all while using the full potential of its 8.5-inch heat-treated steel wedge. The OPS232 sits on a 37-inch wheelbase equipped with 16-inch O.D. 4.8-8 tires and includes a tow bar for easy job site moving.

### SPECIFICATION

ENGINE	KOHLER® SH265 6.5HP 196cc
SPLITTING CAPACITY	25.5" (L) x Ø21.6" 64.7cm (L) x Ø54.8cm
CYCLE TIME	13 seconds
HYDRAULIC CYLINDER	Ø4.5" (Ø11.4cm) x 24" (60.9cm) stroke
HYDRAULIC FLOW RATE	15GPM (56.8LPM), two-stage
HYDRAULIC OIL CAPACITY	8.5gal (32L)
TYPE OF HYDRAULIC OIL	AW32/AW46
HYDRAULIC OIL FILTER	10 micron (1250 mesh) paper with NBR (Buna-N) seals
WEDGE	8.5" (21.6cm) high, heat-treated steel
BEAM	8.5" (21.6cm) foot plate
VALVE	Auto-retract with adjustable detent
WHEELS & TIRES	D.O.T. approved 4.80-8 Ø16" (Ø40.6cm) OD
WHEELBASE	37" (94cm)
COUPLER	2" (5.08cm) ball with safety chains
ASSEMBLED DIMENSIONS & WEIGHT	89.4" (L) x 51.2" (W) x 37.4" (H) @ 529.1lb 227cm (L) x 130cm (W) x 95cm (H) @ 240kg
SHIPPING DIMENSIONS & WEIGHT	70.9" (L) x 31.5" (W) x 19.7" (H) @ 573lb 180cm (L) x 80cm (W) x 50cm (H) @ 260kg
WARRANTY	2-year KOHLER® parts and labor 1-year DK2 chassis



### FEATURES

- Powered by a KOHLER® SH265 6.5HP 196cc engine **1**
- 25.5" x Ø21.6" (64.8cm x Ø54.8cm) log capacity
- 8.5" (21.6cm) heat-treated steel wedge **2**
- 13-second cycling time
- D.O.T. approved Ø16" (Ø40.6cm) OD road tires sitting on a 37" (94cm) wheelbase **3**
- Folds 90° for both horizontal and vertical log splitting capability **4**
- Two-stage 15GPM (56.8LPM) pump
- 8.5 gallon (32 litres) hydraulic fluid capacity
- Auto-retracting adjustable detent valve
- 2" (5.08cm) ball coupler with safety chains **5**
- Includes 2-year KOHLER® engine parts and labor and 1-year DK2 chassis warranty
- **NOT HIGHWAY TOWABLE AND MAX SPEED 25MPH (40KM/H)**





## 40-TON KINETIC HORIZONTAL LOG SPLITTER

### ITEM NUMBERS

OPS240

33

### UPC

826518005746



### DESCRIPTION

Introducing the DK2 POWER OPS240 40-ton kinetic log splitter, powered by a KOHLER® CH270 7HP 208cc Command PRO® engine for outstanding performance. Equipped with an oversized reinforced steel work table, safety lockout and a clam shell quick-access body for easy use and maintenance.

The OPS240 has an 8-inch expansion wedge and an auto-retracting bearing-guided ram to drive through logs up to 22 inches in diameter and up to 22 inches in length. Keep yourself safe while working with its extended stability stand and ATV locking wheels, keeping the splitter securely in place.

### SPECIFICATION

ENGINE	KOHLER® Command PRO® CH270 7HP 208cc
GEARBOX	Direct drive 10.7ft/lb (14.5Nm) gross torque
WHEELS & TIRES	ATV-locking
SPLITTING CAPACITY	Ø22" x 22" (L) Ø55.9cm x 55.9cm (L)
WEDGE	8" (20.32cm), steel
H-BEAM	25" (63.5cm) ground clearance
CYCLE TIME	1 second
COUPLER	2" (5.08cm)
DIMENSIONS	120" (L) x 37" (W) x 44" (H) 304.8cm (L) x 94cm (W) x 111.8cm (H)
WEIGHT	616lb (279.4kg)
SHIPPING DIMENSIONS	71" (L) x 27" (W) x 26" (H) 180.3cm (L) x 68.6cm (W) x 66cm (H)
SHIPPING WEIGHT	690lb (313kg)
WARRANTY	3-year KOHLER® engine 1-year DK2 chassis



### FEATURES

- Powered by a KOHLER® Command PRO® Commercial CH270 7HP 208cc engine **1**
- 8" (20.32cm) solid steel expansion wedge **2**
- Oversized steel worktable with quad-log slides **3**
- H-beam height sits at 25" (63.5cm)
- Heat-treated ram with bearing glide force and auto-retraction
- Extended stability stand
- ATV-locking wheels **4**
- Fits on a 2" (5.08cm) hitch receiver for easy towing
- Quick-release clam shell body for easy access to interior of the unit **5**
- Safety lock out
- Super-quick 1 second cycling time
- Includes 3-year KOHLER® engine and 1-year DK2 chassis warranty
- **OFF-ROAD ONLY AND MAX SPEED 15MPH (24KM/H)**



## 17-INCH x 21-INCH PLATE COMPACTOR

### ITEM NUMBER

OPV425

### UPC

827518008249

### FEATURES

- Powered by a KOHLER® CH270 7HP 208cc Command PRO® Commercial Engine **1**
- 17" (43.2cm) x 21" (53.3cm) solid steel base plate
- Conveniently placed 27.5" (69.9cm) folding handles for easier transportation and stowaway **2**
- Open design to reduce dirt and residue build-up **3**
- Central-mounted, fully enclosed exciter for even compacting force over the entire base plate **4**
- Includes 3-year KOHLER® engine and 1-year DK2 chassis warranty

### DESCRIPTION

Featuring a large 17-inch by 21-inch base plate, the OPV425 plate compactor doesn't disappoint when it comes to compacting performance, and the power that drives this machine comes from a KOHLER® Command PRO® CH270 7HP 208cc engine.

With a compacting force of 3,600lb (16kn) at 4,750 vibrations per minute, this unit is the perfect solution for your compacting needs.

Designed with conveniently placed, 27.5-inch folding handles for easy transportation and storage, open design to reduce dirt build-up, and a central-mounted, fully enclosed exciter for even compacting force over the entire base plate.

### SPECIFICATION

<b>ENGINE</b>	KOHLER® Command PRO® CH270 7HP 208cc
<b>BASE PLATE</b>	17" (43.2cm) x 21" (53.3cm)
<b>HANDLE LENGTH</b>	27.5" (69.9cm)
<b>VIBRATION FREQUENCY</b>	4,750VPM
<b>CENTRIFUGAL FORCE</b>	3,600lb/ft (16kn)
<b>COMPACTING DEPTH</b>	11.8" (30cm)
<b>SPEED</b>	12.6in/sec (32cm/sec)
<b>DIMENSIONS</b>	17" (L) x 21" (W) x 29" (H) 43.2cm (L) x 53.3cm (W) x 73.7cm (H)
<b>WEIGHT</b>	198.4lb (90kg)
<b>SHIPPING DIMENSIONS</b>	18.9" (L) x 26.4" (W) x 28.3" (H) 48cm (L) x 67.1cm (W) x 72cm (H)
<b>SHIPPING WEIGHT</b>	227lb (103kg)
<b>WARRANTY</b>	3-year KOHLER® engine 1-year DK2 chassis



## 1100LB 48V ELECTRIC HYDRAULIC DUMP CART

### ITEM NUMBER

OPD811

35

### UPC

826518005722



### DESCRIPTION

With a wet bucket for sand, gravel, concrete and more, the DK2 POWER OPD811 self-drive electric powered hydraulic dump cart runs for up to 6 hours on one charge with its 48V 20Ah battery and moves it all. Equipped with a hydraulic electric lift, this unit is capable of tipping its wet bucket 90 degrees vertically for easy unloading.

The OPD811 comes with throttle bar speed control and articulated floating rear wheels to keep your load level and steady. Moving around the job site is effortless with forward and reverse speeds of 6 MPH and dual front wheel drive to climb over rough terrain.

### SPECIFICATION

<b>BATTERY</b>	48V 20Ah (4 x 12V series)
<b>PAYLOAD CAPACITY</b>	1,100lb (499kg)
<b>DRIVE WHEELS &amp; TIRES</b>	All-terrain 4.00-8 Ø16" (Ø40.6cm) OD
<b>REAR WHEELS &amp; TIRES</b>	Off-road 4.10-4 Ø10" (Ø25.4cm) OD on Ø5" (Ø12.7cm) rims
<b>MAX SPEED</b>	6mph (9.7km/h)
<b>RUN TIME</b>	6hrs
<b>CHARGE TIME</b>	5hrs
<b>BUCKET</b>	8ft <sup>3</sup> (0.23m <sup>3</sup> ), 45gal (170.3L), sealed steel
<b>COUPLER</b>	2" (5.08cm)
<b>DIMENSIONS</b>	60" (L) x 40" (W) x 40" (H) 152.4cm (L) x 101.6cm (W) x 101.6cm (H)
<b>WEIGHT</b>	572lb (259kg)
<b>SHIPPING DIMENSIONS</b>	54" (L) x 34" (W) x 32" (H) 137.2cm (L) x 86.4cm (W) x 81.3cm (H)
<b>SHIPPING WEIGHT</b>	616lb (279.4kg)
<b>WARRANTY</b>	1-year limited



### FEATURES

- Powered by a 48V 20Ah battery <sup>1</sup>
- 8ft<sup>3</sup> (0.23m<sup>3</sup>) 45gal (170.3L) sealed steel wet bucket <sup>2</sup>
- All-terrain 4.00-8 Ø16" (Ø40.6cm) OD front wheel drive tires, with electric drive up to 6mph (9.7km/h) and off-road 4.10-4 Ø10" (Ø25.4cm) OD rear tires on Ø5" (Ø12.7cm) rims to move effortlessly around job sites <sup>3</sup>
- Hydraulic electric lift cylinder to tip bucket to 90° vertical for easy unloading <sup>4</sup>
- Throttle bar speed control with articulated floating rear wheels keep your load level and steady
- Improved "magic brake" system to brake upon the release of the brake handle, making your hauls safe and secure <sup>5</sup>

## 660 LB GAS-POWERED DUMP CART WITH TRACKS

36



### ITEM NUMBER

OPD511

### UPC

XXXXXXXXXXXX

### DESCRIPTION

The OPD511 660 lb Gas-Powered Dump Cart with Tracks is a tool that is designed to make heavy lifting and transport easier. Powered by a KOHLER® Command PRO® CH270 7 HP 208 cc engine, with 3 forward gears and 1 reverse gear, this gas-powered dump cart can hold up to 660 pounds and has a gas rod tipping capability to make unloading quick and easy. The cart also boasts 7.1-inch off-road tracks for versatile mobility, giving you the ability to traverse difficult terrain with ease. Made from heavy-duty UV powder coated steel, this cart is built to last and withstand harsh outdoor conditions. The detachable 40.1" x 33.9" x 8" bucket is perfect for carrying heavy loads, making it an ideal choice for those who need to transport materials over long distances.

### FEATURES

- Powered by a KOHLER® CH270 7 HP 208 cc Command PRO® commercial engine
- Built to hold up to 660 lbs of weight, making it perfect for heavy-duty outdoor projects
- 3 forward gears and 1 reverse gear, this cart is easy to control and maneuver
- Gas rod tipping capability makes it easy to dump and unload heavy loads
- 7.1" off-road tracks provide versatile mobility and can navigate rough terrain.
- The 40.1" x 33.9" x 8" bucket is detachable and perfect for carrying heavy loads.
- The cart is built with heavy-duty UV powder-coated steel, ensuring that it will last for years to come
- Includes 3-year KOHLER® engine and 1-year DK2 chassis warranty

### SPECIFICATION

<b>ENGINE</b>	KOHLER® Command PRO® CH270 7HP 208cc
<b>LOAD CAPACITY</b>	660 lb (300 kg)
<b>TRANSMISSION</b>	3 forward gears, 1 reverse gear
<b>DUMP MECHANISM</b>	Gas rod driven
<b>TRACKS</b>	7.1" (18 cm) wide
<b>BUCKET</b>	40.1" (L) x 33.9" (W) x 8" (H) 101.9 cm (L) x 86.1 cm (W) x 20.3 cm (H)
<b>CONSTRUCTION</b>	Heavy-duty UV powder-coated steel
<b>WEIGHT</b>	401 lb (182 kg)
<b>SHIPPING DIMENSIONS</b>	45.7" (L) x 30.3" (W) x 34.3" (H) 116.1 cm (L) x 77 cm (W) x 87.1 cm (H)
<b>SHIPPING WEIGHT</b>	449.7 lb (204 kg)
<b>WARRANTY</b>	3-year KOHLER® engine 1-year DK2 chassis

1

2

3

4





### ITEM NUMBER

OPD611

37

### UPC

XXXXXXXXXXXX

### DESCRIPTION

The OPD611 1100 lb Gas-Powered Dump Cart with Tracks is the perfect solution to transport heavy loads with ease. Powered by a KOHLER® Command PRO® CH395 9.5 HP 277 cc engine and equipped with 3 forward gears and 1 reverse gear, this cart can hold up to 1100 lbs, making it ideal for a variety of tasks. The 2.4 GPM hydraulic tipping capability and 7.1" off-road tracks provide versatile mobility, allowing you to easily navigate through rough terrain. The integrated 37.4" x 26.8" (W) x 18.3" (H) bucket can carry heavy loads, and the cart is built with heavy-duty UV powder-coated steel, making it durable and long-lasting. Whether you're working on a construction site, a farm, or just need a reliable cart for your next DIY project, the OPD611 1100 lb Gas-Powered Dump Cart with Tracks is the perfect solution for all your needs.

### FEATURES

- Perfect for hauling heavy loads over rough terrain
- Capable of holding up to 1100 lbs, it is perfect for transporting heavy equipment and materials quickly and easily
- The 2.4 GPM hydraulic tipping capability makes it easy to unload, so you can get back to work quickly.
- 3 forward gears and 1 reverse gear, this dump cart is incredibly versatile and easy to maneuver, even over difficult terrain
- Extra-large integrated 37.4" x 26.8" x 18.3" bucket
- The 7.1" off-road tracks provide excellent traction and mobility, even in muddy or wet conditions.

### SPECIFICATION

<b>ENGINE</b>	KOHLER® Command PRO® CH395 9.5 HP 277 cc
<b>PAYLOAD CAPACITY</b>	1,100lb (499kg)
<b>TRANSMISSION</b>	3 forward gears, 1 reverse gear
<b>DUMP MECHANISM</b>	Hydraulic driven
<b>HYDRAULIC FLOW RATE</b>	2.4 GPM (9 LPM)
<b>TRACKS</b>	7.1" (18 cm) wide
<b>BUCKET</b>	37.4" (L) x 26.8" (W) x 18.3" (H) 95 cm (L) x 68.1 cm (W) x 46.5 cm (H)
<b>CONSTRUCTION</b>	Heavy-duty UV powder-coated steel
<b>WEIGHT</b>	586.4 lb (266 kg)
<b>SHIPPING DIMENSIONS</b>	65.7" (L) x 30.3" (W) x 44.5" (H) 167 cm (L) x 77 cm (W) x 113 cm (H)
<b>SHIPPING WEIGHT</b>	679 lb (308 kg)
<b>WARRANTY</b>	3-year KOHLER® engine 1-year DK2 chassis

## 1271 CFM GAS-POWERED WALK-BEHIND LEAF BLOWER

38



### DESCRIPTION

The DK2 OPB215 is the ultimate solution for tackling even the toughest leaf blowing jobs. With a powerful and reliable KOHLER® RH265 6.5 HP 208 cc engine, this walk-behind leaf blower can move up to 150 miles per hour and deliver 1271 cubic feet per minute of air volume, that means you can clear large areas quickly and efficiently. Whether you're a professional landscaper or a homeowner who takes pride in their yard, the DK2 OPB215 is the perfect tool for keeping your outdoor spaces looking clean and tidy.

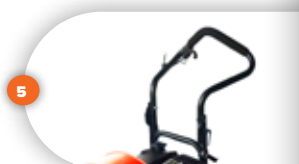

### SPECIFICATION

ENGINE	KOHLER® 2000 Series RH265 6.5HP 196cc
MAX AIR FLOW	150 mph (241.4 km/h)
SPEED	215 ft/sec (65.5 m/sec)
AIR VOLUME (CFM)	1,271 ft <sup>3</sup> /min (36 m <sup>3</sup> /min)
SHIPPING DIMENSIONS	25.6" (L) x 22" (W) x 23.2" (H) 65 cm (L) x 56 cm (W) x 59 cm (H)
SHIPPING WEIGHT	145.5 lb (66 kg)
WARRANTY	1-year limited

### ITEM NUMBER

OPB215

### UPC

XXXXXXXXXXXX

### FEATURES

- Powered by a KOHLER® RH265 6.5 HP 196 cc engine
- Scrolled housing for efficient air flow production at 215 ft/sec (65.5 m/sec) that blows up to 1,271 ft<sup>3</sup>/min (36 m<sup>3</sup>/min) **2**
- Adjustable outlet air deflector for added directional control while blowing leaves, brush, or yard debris at 150 mph (241.1 km/h) **3**
- Front trolley wheel for easy mobility direction **4**
- Ergonomic handle for optimal walk-behind control **5**
- Includes 1-year limited DK2 warranty
- **OFF-ROAD ONLY AND MAX SPEED 15MPH (24KM/H)**

**DIK**  
  
**WIR**

# TWIN CYLINDER 1HP 2-GALLON OIL-FREE SILENT ELECTRIC AIR COMPRESSOR

40



## ITEM NUMBER

AC02G

## UPC

827518008249

## DESCRIPTION

The AC02G is a silent electric oil-free air compressor that can be plugged into any nominal 120V outlet and ready in seconds at 125 PSI with 2 gallons of available compressed air, all at a whisper quiet sound level.

This unit comes equipped with a brushless electric motor, 2 quick-connect hose ports with a regulator dial so the tools are given the air pressure they need to operate at their full potential, and when it comes to moving the AC02G around the job site, it couldn't be any easier with its lightweight, compact design and ergonomic lift handle.

When the job is done and it's time to pack up, just turn the pressure switch off, unplug, and pull the release valve to remove any remaining air pressure.

## SPECIFICATION

<b>POWER</b>	550W/0.75HP / 750W/1.0HP
<b>VOLTAGE</b>	110V / 120V
<b>FREQUENCY</b>	60Hz
<b>SPEED</b>	1,700RPM
<b>DISPLACEMENT</b>	3.8CFM / 4.0CFM
<b>CAPACITY</b>	2gal (7.6L)
<b>MAX PRESSURE</b>	125 PSI (8.6 Bar)
<b>DIMENSIONS</b>	17.3" (L) x 15.8" (W) x 13.9" (H) 44cm (L) x 40.1cm (W) x 35.3cm (H)
<b>WEIGHT</b>	43lb (19.5kg)
<b>SHIPPING DIMENSIONS</b>	18.9" (L) x 16.9" (W) x 15.6" (H) 48cm (L) x 43cm (W) x 39.5cm (H)
<b>SHIPPING WEIGHT</b>	46.3lb (21kg)
<b>WARRANTY</b>	1-year limited



## FEATURES

- Powered by a twin cylinder 1HP (750W) 120V brushless electric motor **1**
- Holds up to 2gal (7.6L) of compressed air at 125 PSI (8.6 Bar)
- Whisper quiet operation
- Durable, spring-loaded pressure switch for easy on/off control
- 2 quick-connect hose ports **2**
- 2 clear analog pressure gauges **3**
- Regulator dial to control the amount of air pressure released at the hose outlets **4**
- Compact, lightweight design with ergonomic handle for easy mobility **5**
- Release valve to remove air pressure from the tank
- Drain petcock drains moisture from the tank and reduce risk of corrosion
- Oil-free operation - no lubrication required
- Thermal overload protection system automatically shuts off the electric motor if it becomes overheated
- Includes 1-year limited DK2 warranty



# TWIN CYLINDER 1HP 4-GALLON OIL-FREE SILENT ELECTRIC AIR COMPRESSOR

## ITEM NUMBER

AC04G

41

## UPC

827518008799

## DESCRIPTION

The AC04G is a silent electric oil-free air compressor that can be plugged into any nominal 120V outlet and ready in seconds at 125 PSI with 4 gallons of available compressed air, all at a whisper quiet sound level.

This unit comes equipped with a brushless electric motor, 2 quick-connect hose ports with a regulator dial so the tools are given the air pressure they need to operate at their full potential, and when it comes to moving the AC04G around the job site, it couldn't be any easier with its lightweight, compact design and ergonomic lift handle.

When the job is done and it's time to pack up, just turn the pressure switch off, unplug, and pull the release valve to remove any remaining air pressure.

## SPECIFICATION

<b>POWER</b>	550W/0.75HP / 750W/1.0HP
<b>VOLTAGE</b>	110V / 120V
<b>FREQUENCY</b>	60Hz
<b>SPEED</b>	1,700RPM
<b>DISPLACEMENT</b>	3.8CFM / 4.0CFM
<b>CAPACITY</b>	4gal (15.1L)
<b>MAX PRESSURE</b>	125 PSI (8.6 Bar)
<b>DIMENSIONS</b>	17.4" (L) x 15.6" (W) x 20.8" (H) 44.2cm (L) x 39.6cm (W) x 52.8cm (H)
<b>WEIGHT</b>	54lb (24.5kg)
<b>SHIPPING DIMENSIONS</b>	18.7" (L) x 16.5" (W) x 22.4" (H) 47.5cm (L) x 41.9cm (W) x 56.9cm (H)
<b>SHIPPING WEIGHT</b>	57.3lb (26kg)
<b>WARRANTY</b>	1-year limited



## FEATURES

- Powered by a twin cylinder 1HP (750W) 120V brushless electric motor **1**
- Holds up to 4gal (15.1L) of compressed air at 125 PSI (8.6 Bar)
- Whisper quiet operation
- Durable, spring-loaded pressure switch for easy on/off control
- 2 quick-connect hose ports **2**
- 2 clear analog pressure gauges **3**
- Regulator dial to control the amount of air pressure released at the hose outlets **4**
- Compact, lightweight design with ergonomic handle for easy mobility **5**
- Release valve to remove air pressure from the tank
- Drain petcock drains moisture from the tank and reduce risk of corrosion
- Oil-free operation - no lubrication required
- Thermal overload protection system automatically shuts off the electric motor if it becomes overheated
- Includes 1-year limited DK2 warranty

# TWIN CYLINDER 2HP 10-GALLON OIL-FREE SILENT ELECTRIC AIR COMPRESSOR

## ITEM NUMBER

AC10G

## UPC

827518008775

## FEATURES

- Powered by a twin cylinder 2HP (1491.4W) 120V AC brushless electric motor <sup>1</sup>
- Holds up to 10gal (37.9L) of compressed air at 150 PSI (10.3 Bar)
- Whisper quiet operation
- Durable, spring-loaded pressure switch for easy on/off control
- 2 quick-connect hose ports <sup>2</sup>
- 2 clear analog pressure gauges <sup>3</sup>
- Regulator dial to control the amount of air pressure released at the hose outlets <sup>4</sup>
- Ergonomic handle <sup>5</sup>
- Never flat Ø8" (Ø20.3cm) OD x 1.75" (4.4cm) tires for easy mobility <sup>6</sup>
- Release valve to remove air pressure from the tank
- Drain petcock drains moisture from the tank and reduce risk of corrosion
- Oil-free operation - no lubrication required
- Thermal overload protection system automatically shuts off the electric motor if it becomes overheated
- Includes 1-year limited DK2 warranty

42



## DESCRIPTION

The AC10G is a silent electric oil-free air compressor that can be plugged into any nominal 120V outlet and ready in seconds at 150 PSI with 10 gallons of available compressed air, all at a whisper quiet sound level. Equipped with a brushless electric motor, 2 quick-connect hose ports with a regulator dial so the tools operate at full potential, and when it comes to moving the AC10G around the job site, it couldn't be any easier with its ergonomic lift handle and never flat wheels and tires. When the job is done and it's time to pack up, just turn the pressure switch off, unplug, and pull the release valve to remove any remaining air pressure.



## SPECIFICATION

<b>POWER</b>	1491.4W / 2HP
<b>VOLTAGE</b>	120V AC
<b>FREQUENCY</b>	60Hz
<b>SPEED</b>	1,700RPM
<b>DISPLACEMENT</b>	4.5CFM (90 PSI / 6.2 Bar) 5.5CFM (40 PSI / 2.8 Bar)
<b>TANK</b>	Vertical
<b>CAPACITY</b>	10gal (37.9L)
<b>MAX PRESSURE</b>	150 PSI (10.3 Bar)
<b>DIMENSIONS</b>	19.5" (L) x 16" (W) x 32.5" (H) 49.5cm (L) x 40.6cm (W) x 82.6cm (H)
<b>WEIGHT</b>	88.2lb (40kg)
<b>SHIPPING DIMENSIONS</b>	20" (L) x 19" (W) x 36.3" (H) 50.8cm (L) x 48.3cm (W) x 92.2cm (H)
<b>SHIPPING WEIGHT</b>	97lb (44kg)
<b>WARRANTY</b>	1-year limited

# TWIN CYLINDER 2HP 20-GALLON OIL-FREE SILENT ELECTRIC AIR COMPRESSOR

## ITEM NUMBER

AC20G

43

## UPC

827518008782

## DESCRIPTION

The AC20G is a silent electric oil-free air compressor that can be plugged into any nominal 120V outlet and ready in seconds at 150 PSI with 20 gallons of available compressed air, all at a whisper quiet sound level. Equipped with a brushless electric motor, 2 quick-connect hose ports with a regulator dial so the tools operate at full potential, and when it comes to moving the AC20G around the job site, it couldn't be any easier with its ergonomic lift handle and never flat wheels and tires. When the job is done and it's time to pack up, just turn the pressure switch off, unplug, and pull the release valve to remove any remaining air pressure.

## SPECIFICATION

<b>POWER</b>	1491.4W / 2HP
<b>VOLTAGE</b>	120V AC
<b>FREQUENCY</b>	60Hz
<b>SPEED</b>	1,700RPM
<b>DISPLACEMENT</b>	4.5CFM (90 PSI / 6.2 Bar) 5.5CFM (40 PSI / 2.8 Bar)
<b>TANK</b>	Vertical ASME Certified
<b>CAPACITY</b>	20gal (75.7L)
<b>MAX PRESSURE</b>	150 PSI (10.3 Bar)
<b>DIMENSIONS</b>	19.5" (L) x 16" (W) x 44.5" (H) 49.5cm (L) x 40.6cm (W) x 113cm (H)
<b>WEIGHT</b>	106.9lb (48.5kg)
<b>SHIPPING DIMENSIONS</b>	20" (L) x 18.3" (W) x 47.3" (H) 50.8cm (L) x 46.5cm (W) x 120.1cm (H)
<b>SHIPPING WEIGHT</b>	116.8lb (53kg)
<b>WARRANTY</b>	1-year limited



## FEATURES

- Powered by a twin cylinder 2HP (1491.4W) 120V AC brushless electric motor <sup>1</sup>
- Holds up to 20gal (75.7L) of compressed air at 150 PSI (10.3 Bar)
- Whisper quiet operation
- Durable, spring-loaded pressure switch for easy on/off control
- 2 quick-connect hose ports <sup>2</sup>
- 2 clear analog pressure gauges <sup>3</sup>
- Regulator dial to control the amount of air pressure released at the hose outlets <sup>4</sup>
- Ergonomic handle <sup>5</sup>
- Ø8" (Ø20.3cm) OD x 1.75" (4.4cm) tires for easy mobility <sup>6</sup>
- Release valve to remove air pressure from the tank
- Drain petcock drains moisture from the tank and reduce risk of corrosion
- Oil-free operation - no lubrication required
- Thermal overload protection system automatically shuts off the electric motor if it becomes overheated
- Includes 1-year limited DK2 warranty



**DIA**<sup>®</sup>

LiFePO4 TECHNOLOGY



LiFePO<sub>4</sub>  
TECHNOLOGY



FEATURES

# 3-INCH 57.6V LI-ION POWERED DISK CHIPPER SHREDDER

## ITEM NUMBER

OPC503EV

45

## UPC

827518009154



## DESCRIPTION

The DK2 OPC503EV 3-Inch 57.6V Li-ion Powered Disk Chipper Shredder is the ultimate tool for efficient and effective yard work. With an EV motor and advanced LiFePO<sub>4</sub> technology, this machine is designed to handle even the toughest yard waste with ease. Whether you're chipping branches, shredding leaves, or converting brush into mulch, the DK2 3-Inch 57.6V Li-ion Powered Disk Chipper Shredder will make quick work of the task. With its compact size and user-friendly design, it's easy to maneuver and operate, making it the perfect tool for homeowners and landscapers alike. Upgrade your yard work game with the DK2 OPC503EV today.

## SPECIFICATION

<b>BATTERY</b>	57.6V Max, 1024Wh, 20Ah LiFePO <sub>4</sub>
<b>MOTOR</b>	2,000Wh 3,500 RPM cordless brushless EV motor
<b>TORQUE</b>	4.1 ft/lb (5.5 Nm) rated 18.4 ft/lb (25 Nm) peak
<b>CHARGER</b>	120V AC/DC 200W
<b>WHEELS &amp; TIRES</b>	ATV-locking 145/70-6 Ø13.75" (Ø34.9 cm) O.D. x 5.25" (13.3 cm)
<b>WHEELBASE</b>	28" (71.1 cm)
<b>CHIPPING CAPACITY</b>	Ø3" (Ø7.6 cm) (side feed chute) Ø3/8" (Ø0.95 cm) (top-loading hopper)
<b>CUTTERS</b>	Double edge chipper blades and quad hammer shredders
<b>CHIPPER SHREDDER</b>	Leaves, brush, garden compost
<b>EXPULSION CHUTE</b>	Adjustable
<b>COUPLER</b>	2" (5.08 cm)
<b>DIMENSIONS</b>	71" (L) x 36.5" (W) x 48" (H) 180.3 cm (L) x 92.7 cm (W) x 121.9 cm (H)
<b>WEIGHT</b>	218.5 lb (99.1 kg)
<b>SHIPPING DIMENSIONS</b>	43.3" (L) x 23.6" (W) x 24.4" (H) 110 cm (L) x 60 cm (W) x 62 cm (H)
<b>SHIPPING WEIGHT</b>	238.5 lb (108.2 kg)
<b>WARRANTY</b>	1-year limited



## FEATURES

- Powered by a 57.6V, 1,024Wh, 20Ah, LiFePO<sub>4</sub> lithium-ion battery **1**
- Equipped with a 3,500 RPM EV motor
- Comes with 120V AC/DC 200W charger
- Chipper shredder with double edge chip and quad hammer shredders
- Chips through trees up to Ø3" (Ø7.6 cm) through the side feed chute and brush up to Ø3/8" (Ø0.95 cm) through the top-loading hopper
- Extra large feed chutes **2**
- Drop stand and handy removable tow bar **3**
- 145/70-6 Ø13.75" (Ø34.9 cm) O.D. x 5.25" (13.3 cm) tires on ATV-locking wheels with a 28" (71.1 cm) wheelbase **4**
- Includes 1-year limited DK2 warranty
- **OFF-ROAD ONLY AND MAX SPEED 15MPH (24KM/H)**



LiFePO4  
TECHNOLOGY



FEATURES

# 20-TON 57.6V LI-ION POWERED HORIZONTAL HYDRAULIC LOG SPLITTER

## ITEM NUMBER

OPS220EV

## UPC

827518009178

## FEATURES

- Powered by a 57.6V, 1,024Wh, 20Ah, LiFePO4 lithium-ion battery <sup>1</sup>
- Equipped with a 3,500 RPM EV motor
- Comes with 120V AC/DC 200W charger
- 10" (25.4 cm) pneumatic tires <sup>2</sup>
- Solid heat-treated steel wedge <sup>3</sup>
- Steel plunger beam with auto-retracting valve capable of splitting logs at Ø16" (Ø40.6 cm) in diameter and 20.5" (52.1 cm) in length <sup>4</sup>
- Includes 1-year limited DK2 warranty

46



## DESCRIPTION

Introducing the DK2 OPS220EV Hydraulic Log Splitter, the ultimate tool for splitting logs with ease. This powerful machine is equipped with an EV motor and advanced LiFePO4 technology, ensuring that it's both durable and efficient. With a 20-ton split force, it can handle even the toughest logs with ease, and the hydraulic system ensures that you can split logs quickly and easily. Whether you're a professional logger or just someone who needs to split a few logs for the fireplace, this log splitter is the perfect tool for the job.

## SPECIFICATION

<b>BATTERY</b>	57.6V Max, 1024Wh, 20Ah LiFePO4
<b>MOTOR</b>	2,000Wh 3,500 RPM cordless brushless EV motor
<b>TORQUE</b>	4.1 ft/lb (5.5 Nm) rated 18.4 ft/lb (25 Nm) peak
<b>CHARGER</b>	120V AC/DC 200W
<b>WHEELS &amp; TIRES</b>	10" (25.4 cm) pneumatic
<b>SPLITTING CAPACITY</b>	Ø16" (Ø40.6 cm) x 20.5" (52.1 cm)
<b>WEDGE</b>	Solid heat-treated steel
<b>TYPE OF HYDRAULIC OIL</b>	AW32/AW46
<b>VALVE</b>	Auto-retract with adjustable detent
<b>SHIPPING DIMENSIONS</b>	35.8" (L) x 23.2" (W) x 17.1" (H) 91 cm (L) x 59 cm (W) x 43.5 cm (H)
<b>SHIPPING WEIGHT</b>	165.3 lb (75 kg)
<b>WARRANTY</b>	1-year limited





LiFePO4  
TECHNOLOGY



FEATURES

# 1271 CFM 57.6V LI-ION POWERED WALK-BEHIND LEAF BLOWER

## ITEM NUMBER

OPB480EV

47

## UPC

827518009161

## FEATURES

- Powered by a 57.6V, 1,024Wh, 20Ah, LiFePO4 lithium-ion battery **1**
- Equipped with a 3,500 RPM EV motor
- Comes with 120V AC/DC 200W charger
- Scrolled housing for efficient air flow production at 215 ft/sec (65.5 m/sec) that blows up to 1,271 ft<sup>3</sup>/min (36 m<sup>3</sup>/min) **2**
- Adjustable outlet air deflector for added directional control while blowing leaves, brush, or yard debris at 150 mph (241.1 km/h) **3**
- Front trolley wheel for easy mobility direction **4**
- Ergonomic handle for optimal walk-behind control **5**
- Includes 1-year limited DK2 warranty
- **OFF-ROAD ONLY AND MAX SPEED 15MPH (24KM/H)**



## DESCRIPTION

The DK2 OPB480EV is the ultimate solution for tackling even the toughest leaf blowing jobs. With a powerful EV motor and advanced LiFePO4 technology, this walk-behind leaf blower can move up to 150 miles per hour and deliver 1271 cubic feet per minute of air volume. That means you can clear large areas quickly and efficiently, without having to stop and recharge your battery. Whether you're a professional landscaper or a homeowner who takes pride in their yard, the DK2 OPB480EV is the perfect tool for keeping your outdoor spaces looking clean and tidy.



## SPECIFICATION

<b>BATTERY</b>	57.6V Max, 1024Wh, 20Ah LiFePO4
<b>MOTOR</b>	2,000Wh 3,500 RPM cordless brushless EV motor
<b>TORQUE</b>	4.1 ft/lb (5.5 Nm) rated 18.4 ft/lb (25 Nm) peak
<b>CHARGER</b>	120V AC/DC 200W
<b>MAX AIR FLOW</b>	150 mph (241.4 km/h)
<b>SPEED</b>	215 ft/sec (65.5 m/sec)
<b>AIR VOLUME (CFM)</b>	1,271 ft <sup>3</sup> /min (36 m <sup>3</sup> /min)
<b>SHIPPING DIMENSIONS</b>	25.6" (L) x 22" (W) x 23.2" (H) 65 cm (L) x 56 cm (W) x 59 cm (H)
<b>SHIPPING WEIGHT</b>	145.5 lb (66 kg)
<b>WARRANTY</b>	1-year limited



LiFePO4  
TECHNOLOGY



FEATURES

## 2,200 PSI 2.4 GPM 57.6V LI-ION POWERED PRESSURE WASHER

48



### DESCRIPTION

The DK2 OPW480EV 2200 PSI 57.6V Li-ion Powered Pressure Washer is the ultimate tool for cleaning your outdoor spaces. With an EV motor and advanced LiFePO4 technology, this pressure washer delivers the power you need to blast away dirt, grime, and even stubborn stains. It's perfect for cleaning decks, patios, sidewalks, driveways, and more. And with a 2200 PSI rating, it's powerful enough to tackle even the toughest jobs. So whether you're a homeowner or a professional cleaner, the DK2 OPW480EV is the pressure washer you need to get the job done right.

### ITEM NUMBER

OPW480EV

### UPC

827518009147

### FEATURES

- Powered by a 57.6V, 1,024Wh, 20Ah, LiFePO4 lithium-ion battery **1**
- Equipped with a 3,500 RPM EV motor
- Comes with 120V AC/DC 200W charger
- 3-piston axial cam pump creates max pressure of 2,200 PSI (150 Bar) and a flow rate of 2.4 GPM (9 LPM)
- 25-foot pressure hose
- Metal lance and gun
- 3 different spray nozzles for various applications
- Never flat tires **2**
- Comfortable padded handle for easy mobility **3**
- Pressure hose rack and spray nozzle storage slots all in one convenient location below the mobility handle **4**
- Includes 1-year limited DK2 warranty



### SPECIFICATION

<b>BATTERY</b>	57.6V Max, 1024Wh, 20Ah LiFePO4
<b>MOTOR</b>	2,000Wh 3,500 RPM cordless brushless EV motor
<b>TORQUE</b>	4.1 ft/lb (5.5 Nm) rated 18.4 ft/lb (25 Nm) peak
<b>CHARGER</b>	120V AC/DC 200W
<b>PUMP</b>	3-piston axial cam
<b>MAX PRESSURE</b>	2,200 PSI (150 Bar)
<b>FLOW RATE</b>	2.4 GPM (9 LPM)
<b>SHIPPING DIMENSIONS</b>	21.7" (L) x 18.5" (W) x 22" (H) 55cm (L) x 47cm (W) x 56cm (H)
<b>SHIPPING WEIGHT</b>	90.4lb (41kg)
<b>WARRANTY</b>	1-year limited



**DK** **TRAILERS**®





## 4FT x 6FT SINGLE AXLE LANDSCAPE TRAILER

52



### ITEM NUMBER

MMT4X6

### UPC

826518004831

### DESCRIPTION

The MMT4X6 is specially designed for handling a variety of hauling tasks; the perfect solution for anyone needing to pull a trailer behind a small vehicle, full size truck, lawn tractor, or ATV and engineered to provide exceptional balance and ease of mobility without giving up one ounce of payload capacity. Made from 100% welded tubular steel with expanded steel decks and DK2's back gate design is multi-purpose and can sit flat in the bed, up in a vertical position, or lying down as a ramp.

### SPECIFICATION

<b>PAYLOAD CAPACITY</b>	1,295lb (587.4kg)
<b>GVWR</b>	1,600lb (725.7kg)
<b>WHEELS &amp; TIRES</b>	D.O.T. 4.80-12 bias tire on 12" (30.5cm) rim with 5 x 4.5" (11.4cm) bolt pattern
<b>MATERIAL</b>	Fully welded heavy-duty UV powder coated tubular steel
<b>SIDE PANELS</b>	Solid steel
<b>GATE</b>	36" (91.4cm) square tube steel ramp and round tube steel exterior
<b>FLOORING</b>	Corrugated steel panel
<b>DUMP BED</b>	2-position, axle-mounted with quick-release lock pin
<b>LIGHTING</b>	Pre-wired, quick-connect D.O.T LED
<b>BED DIMENSIONS</b>	72" (L) x 48" (W) 182.9cm (L) x 121.9cm (W)
<b>FLOOR HEIGHT</b>	18" (45.7cm)
<b>HITCH HEIGHT</b>	14" (35.6cm)
<b>DIMENSIONS</b>	152" (L) x 64" (W) x 26" (H) 386.1cm (L) x 162.6cm (W) x 66cm (H)
<b>WEIGHT</b>	302lb (137kg)
<b>SHIPPING DIMENSIONS</b>	78" (L) x 52" (W) x 9" (H) 198.1cm (L) x 132.1cm (W) x 22.9cm (H)
<b>SHIPPING WEIGHT</b>	305lb (138.3kg)
<b>WARRANTY</b>	1-year limited



### FEATURES

- Constructed with fully welded heavy-duty UV powder-coated tubular steel **1**
- Corrugated steel floor panel **2**
- 36" (91.4cm) square tube steel ramp and round tube steel exterior **3**
- Solid square tube cambered axle
- 2-position axle-mounted dump bed with quick release lock pin **4**
- D.O.T. 4.80-12 bias tires on a 12" (30.5cm) rim with 5 x 4.5" (11.4cm) bolt pattern **5**
- Heavy-duty tail light protectors
- Quick-connect D.O.T. LED lighting with side markers
- Ships in a single package
- 2" (5.08cm) coupler
- Includes all necessary paperwork for registration

## 3-IN-1 UTILITY TRAILER

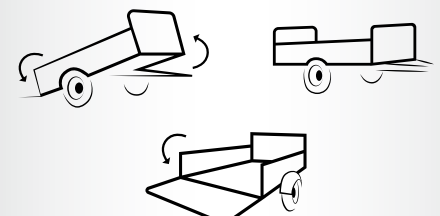

## 4FT x 6FT SINGLE AXLE OPEN RAIL LANDSCAPE TRAILER

### ITEM NUMBER

MMT4X60

53

### UPC

826518005623



### DESCRIPTION

The MMT4X60 is specially designed for handling a variety of hauling tasks; the perfect solution for anyone needing to pull a trailer behind a small vehicle, full size truck, lawn tractor, or ATV and engineered to provide exceptional balance and ease of mobility without giving up one ounce of payload capacity. Made from 100% welded tubular steel with expanded steel decks and DK2's back gate design is multi-purpose and can sit flat in the bed, up in a vertical position, or lying down as a ramp.

### SPECIFICATION

<b>PAYLOAD CAPACITY</b>	1,295lb (587.4kg)
<b>GVWR</b>	1,600lb (725.7kg)
<b>WHEELS &amp; TIRES</b>	D.O.T. 4.80-12 bias tire on 12" (30.5cm) rim with 5 x 4.5" (11.4cm) bolt pattern
<b>MATERIAL</b>	36" (91.4cm) square tube steel ramp and round tube steel exterior
<b>RAILS</b>	Open design, tubular steel
<b>GATE</b>	36" (91.4cm) square tube steel ramp and round tube steel exterior
<b>FLOORING</b>	Corrugated steel panel
<b>DUMP BED</b>	2-position, axle-mounted with quick-release lock pin
<b>LIGHTING</b>	Pre-wired, quick-connect D.O.T LED
<b>BED DIMENSIONS</b>	72" (L) x 48" (W) 182.9cm (L) x 121.9cm (W)
<b>FLOOR HEIGHT</b>	18" (45.7cm)
<b>HITCH HEIGHT</b>	14" (35.6cm)
<b>DIMENSIONS</b>	152" (L) x 64" (W) x 26" (H) 386.1cm (L) x 162.6cm (W) x 66cm (H)
<b>WEIGHT</b>	302lb (137kg)
<b>SHIPPING DIMENSIONS</b>	78" (L) x 52" (W) x 9" (H) 198.1cm (L) x 132.1cm (W) x 22.9cm (H)
<b>SHIPPING WEIGHT</b>	305lb (138.3kg)
<b>WARRANTY</b>	1-year limited

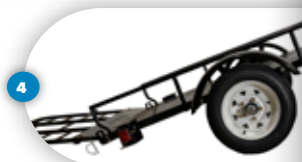

### FEATURES

- Constructed with fully welded heavy-duty UV powder-coated tubular steel
- Tubular steel open rail design **1**
- Corrugated steel floor panel **2**
- 36" (91.4cm) square tube steel ramp and round tube steel exterior **3**
- Solid square tube cambered axle
- 2-position axle-mounted dump bed with quick release lock pin **4**
- D.O.T. 4.80-12 bias tires on a 12" (30.5cm) rim with 5 x 4.5" (11.4cm) bolt pattern **5**
- Heavy-duty tail light protectors
- Quick-connect D.O.T. LED lighting with side markers
- Ships in a single package
- 2" (5.08cm) coupler
- Includes all necessary paperwork for registration

### 3-IN-1 UTILITY TRAILER

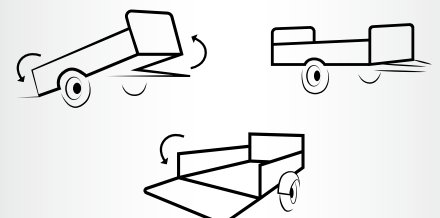

## 4FT x 6FT SINGLE AXLE OPEN RAIL GALVANIZED LANDSCAPE TRAILER

54



### ITEM NUMBER

MMT4X6OG

### UPC

827518008119

### DESCRIPTION

The MMT4X6OG is specially designed for handling a variety of hauling tasks; the perfect solution for anyone needing to pull a trailer behind a small vehicle, full size truck, lawn tractor, or ATV and engineered to provide exceptional balance and ease of mobility without giving up one ounce of payload capacity. Made from 100% welded hot-dipped galvanized tubular steel with expanded steel decks and DK2's back gate design is multi-purpose and can sit flat in the bed, up in a vertical position, or lying down as a ramp.

### SPECIFICATION

<b>PAYLOAD CAPACITY</b>	1,295lb (587.4kg)
<b>GVWR</b>	1,600lb (725.7kg)
<b>WHEELS &amp; TIRES</b>	D.O.T. 4.80-12 bias tire on 12" (30.5cm) rim with 5 x 4.5" (11.4cm) bolt pattern
<b>MATERIAL</b>	Fully welded heavy-duty hot-dipped galvanized tubular steel
<b>RAILS</b>	Open design, tubular steel
<b>GATE</b>	36" (91.4cm) square tube steel ramp and round tube steel exterior
<b>FLOORING</b>	Corrugated panel
<b>DUMP BED</b>	2-position, axle-mounted with quick-release lock pin
<b>LIGHTING</b>	Pre-wired, quick-connect D.O.T LED
<b>BED DIMENSIONS</b>	72" (L) x 48" (W) 182.9cm (L) x 121.9cm (W)
<b>FLOOR HEIGHT</b>	18" (45.7cm)
<b>HITCH HEIGHT</b>	14" (35.6cm)
<b>DIMENSIONS</b>	152" (L) x 64" (W) x 26" (H) 386.1cm (L) x 162.6cm (W) x 66cm (H)
<b>WEIGHT</b>	302lb (137kg)
<b>SHIPPING DIMENSIONS</b>	78" (L) x 52" (W) x 9" (H) 198.1cm (L) x 132.1cm (W) x 22.9cm (H)
<b>SHIPPING WEIGHT</b>	305lb (138.3kg)
<b>WARRANTY</b>	1-year limited



### FEATURES

- Constructed with fully welded heavy-duty hot-dipped galvanized tubular steel
- Tubular steel open rail design **1**
- Corrugated steel floor panel **2**
- 36" (91.4cm) square tube steel ramp and round tube steel exterior **3**
- Solid square tube cambered axle
- 2-position axle-mounted dump bed with quick release lock pin **4**
- D.O.T. 4.80-12 bias tires on a 12" (30.5cm) rim with 5 x 4.5" (11.4cm) bolt pattern **5**
- Heavy-duty tail light protectors
- Quick-connect D.O.T. LED lighting with side markers
- Ships in a single package
- 2" (5.08cm) coupler
- Includes all necessary paperwork for registration

## 3-IN-1 UTILITY TRAILER

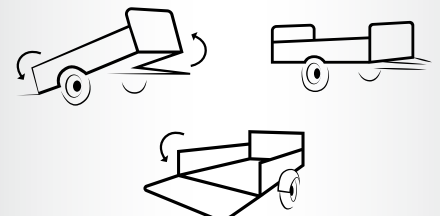

## 4FT x 8FT SINGLE AXLE FOLDING UTILITY TRAILER

### ITEM NUMBER

MFT4X8

55

### UPC

827518007150



### DESCRIPTION

The trailer you've always needed has arrived with the DK2 MFT4X8 folding trailer kit. High-performing, durable and versatile, this trailer is ready for work. Built with a patented welded steel frame and deck for added strength and easy assembly, you'll spend less time reading manuals and more time on the road. The DK2 MFT4X8 is coated with high-performance anti-slip textured UV powder, all while maintaining its complete folding functionality. When it comes to trailers – there's truly nothing like it.

### SPECIFICATION

<b>PAYLOAD CAPACITY</b>	1,450lb (657.7kg)
<b>GVWR</b>	1,720lb (780.2kg)
<b>WHEELS &amp; TIRES</b>	D.O.T. 5.30-12 6-ply tire, 80 PSI (5.5 Bar) cold
<b>MATERIAL</b>	Fully welded heavy-duty UV powder coated tubular steel
<b>RAILS</b>	Open design, tubular steel <b>(sold separately)</b>
<b>FLOORING</b>	Solid steel, anti-slip textured UV powder coated steel
<b>LIGHTING</b>	Pre-wired, Quick-connect D.O.T LED with flat 4-wire harness and connector
<b>BED DIMENSIONS</b>	96" (L) x 48" (W) 243.8cm (L) x 121.9cm (W)
<b>DIMENSIONS</b>	135" (L) x 62.3" (W) x 20" (H) 342.9cm (L) x 158.2cm (W) x 50.8cm (H)
<b>WEIGHT</b>	262lb (118.8kg)
<b>SHIPPING DIMENSIONS</b>	48.4" (L) x 62.2" (W) x 7.9" (H) 122.9cm (L) x 158cm (W) x 20.1cm (H)
<b>SHIPPING WEIGHT</b>	300lb (136.1kg)
<b>WARRANTY</b>	1-year limited



### FEATURES

- Folding design to fit into compact spaces vertically **1**
- Constructed with fully welded heavy-duty UV powder coated tubular steel
- Solid steel bed with high-performance anti-slip textured UV powder coating **2**
- 5.30-12 6-ply tires **3**
- Trolley wheels for easy stowaway transport while folded **4**
- Pre-wired quick-connect D.O.T LED lighting with flat 4-wire harness and connector
- 2" (5.08cm) coupler with safety chain and S-hook
- 8 stake holes for the MFT4X8RK fully welded UV powder coated tubular steel open rail kit **(sold separately)** **5**
- Includes all necessary paperwork for registration

### FOLDING DESIGN

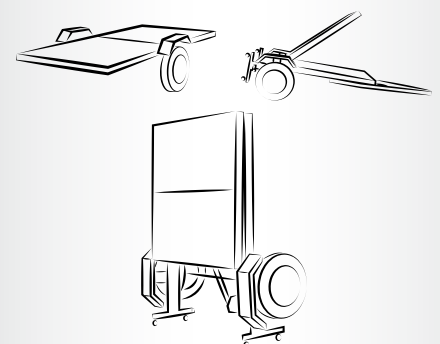

## 4.5FT x 7.5FT SINGLE AXLE MULTI-UTILITY TRAILER

56



### ITEM NUMBER

MMT5X7

### UPC

826518003391

### DESCRIPTION

This single axle multi-utility trailer from DK2 is one of the most versatile trailers on the market. Sitting on a solid square tube cambered axle with 12-inch, 6-ply bias tires and a load capacity of 1,639 pounds. When the front and back load-bearing gates are down, the trailer bed extends to nearly 12 feet in length, and the tilt/dump capability that makes it easy to load or unload heavy items. Fabricated from 100% steel, all of the components are reinforced, adjustable, removable and/or interchangeable.

### SPECIFICATION

<b>PAYLOAD CAPACITY</b>	1,639lb (743.4kg)
<b>GVWR</b>	2,090lb (948kg)
<b>WHEELS &amp; TIRES</b>	D.O.T. 5.30-12 6-ply radial tire with 5 x 4.5" (11.4cm) bolt pattern
<b>MATERIAL</b>	Fully welded heavy-duty UV powder coated tubular steel
<b>SIDE PANELS</b>	Corrugated reinforced steel
<b>DROP GATES</b>	24" (61cm) load-bearing corrugated reinforced steel
<b>FLOORING</b>	Corrugated reinforced steel panel
<b>DUMP BED</b>	2-position, axle-mounted with quick-release lock pin
<b>LIGHTING</b>	Pre-wired, quick-connect D.O.T LED
<b>BED DIMENSIONS</b>	88" (L) x 52" (W) 223.5cm (L) x 132.1cm (W)
<b>FLOOR HEIGHT</b>	20" (50.8cm)
<b>HITCH HEIGHT</b>	16" (40.6cm)
<b>DIMENSIONS</b>	177" (L) x 65" (W) x 36" (H) 449.6cm (L) x 165.1cm (W) x 91.4cm (H)
<b>WEIGHT</b>	451lb (204.6kg)
<b>SHIPPING DIMENSIONS</b>	88" (L) x 55" (W) x 9" (H) 223.5cm (L) x 139.7cm (W) x 22.9cm (H)
<b>SHIPPING WEIGHT</b>	460lb (208.7kg)
<b>WARRANTY</b>	1-year limited



### FEATURES

- Constructed with fully welded heavy-duty UV powder-coated tubular steel
- Corrugated reinforced steel floor panel **1**
- Corrugated reinforced steel side panels **2**
- 24" (61cm) load-bearing corrugated steel drop gates, extending the length of the trailer to 11.3ft (3.4m) **3**
- Solid square tube cambered axle
- 2-position axle-mounted dump bed with quick release lock pin **4**
- D.O.T. 5.30-12 radial tires with 5 x 4.5" (11.4cm) bolt pattern **5**
- Heavy-duty tail light protectors
- Quick-connect D.O.T. LED lighting with side markers
- Ships in a single package
- 2" (5.08cm) coupler on an A-frame tongue for added stability
- Includes all necessary paperwork for registration

## 5-IN-1 UTILITY TRAILER

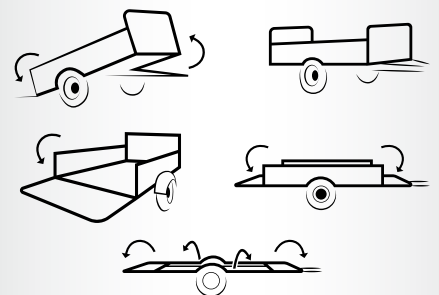



## 4.5FT x 7.5FT SINGLE AXLE MULTI-UTILITY TRAILER WITH DRIVE-UP GATE

### ITEM NUMBER

MMT5X7-DUG

57

### UPC

826518005296

### DESCRIPTION

This single axle multi-utility trailer from DK2 is one of the most versatile trailers on the market. Sitting on a solid square tube cambered axle with 12-inch, 6-ply bias tires and a load capacity of 1,639 pounds. The MMT5X7-DUG comes with a 24-inch front load-bearing gate and a 40-inch rear drive-up gate, and a tilt/dump capability that makes it easy to load or unload heavy items. Fabricated from 100% steel, all of the components are reinforced, adjustable, removable and/or interchangeable.

### SPECIFICATION

<b>PAYLOAD CAPACITY</b>	1,639lb (743.4kg)
<b>GVWR</b>	2,090lb (948kg)
<b>WHEELS &amp; TIRES</b>	D.O.T. 5.30-12 6-ply radial tire with 5 x 4.5" (11.4cm) bolt pattern
<b>MATERIAL</b>	Fully welded heavy-duty UV powder coated tubular steel
<b>SIDE PANELS</b>	Corrugated reinforced steel
<b>GATES</b>	40" (101.6cm) expanded mesh and tubular steel rear ramp gate and 24" (61cm) load-bearing corrugated reinforced steel front gate
<b>FLOORING</b>	Corrugated reinforced steel panel
<b>DUMP BED</b>	2-position, axle-mounted with quick-release lock pin
<b>LIGHTING</b>	Pre-wired, quick-connect D.O.T LED
<b>BED DIMENSIONS</b>	88" (L) x 52" (W) 223.5cm (L) x 132.1cm (W)
<b>FLOOR HEIGHT</b>	20" (50.8cm)
<b>HITCH HEIGHT</b>	16" (40.6cm)
<b>DIMENSIONS</b>	177" (L) x 65" (W) x 36" (H) 449.6cm (L) x 165.1cm (W) x 91.4cm (H)
<b>WEIGHT</b>	451lb (204.6kg)
<b>SHIPPING DIMENSIONS</b>	88" (L) x 55" (W) x 9" (H) 223.5cm (L) x 139.7cm (W) x 22.9cm (H)
<b>SHIPPING WEIGHT</b>	460lb (208.7kg)
<b>WARRANTY</b>	1-year limited



### FEATURES

- Constructed with fully welded heavy-duty UV powder-coated tubular steel
- Corrugated reinforced steel floor panel **1**
- Corrugated reinforced steel side panels **2**
- 40" (101.6cm) expanded mesh and tubular steel rear ramp gate **3**
- 24" (61cm) load-bearing corrugated steel front drop gate
- Solid square tube cambered axle
- 2-position axle-mounted dump bed with quick release lock pin **4**
- D.O.T. 5.30-12 radial tires with 5 x 4.5" (11.4cm) bolt pattern **5**
- Heavy-duty tail light protectors
- Quick-connect D.O.T. LED lighting with side markers
- Ships in a single package
- 2" (5.08cm) coupler on an A-frame tongue for added stability
- Includes all necessary paperwork for registration

## 5-IN-1 UTILITY TRAILER

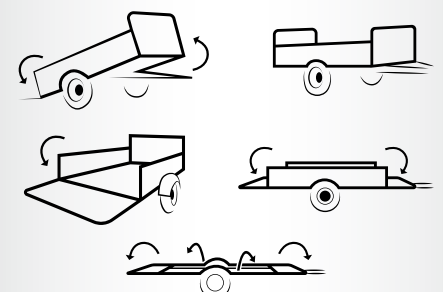

## 4.5FT x 7.5FT SINGLE AXLE MULTI-UTILITY GALVANIZED TRAILER

58



### ITEM NUMBER

MMT5X7G

### UPC

826518003391

### DESCRIPTION

This single axle multi-utility trailer from DK2 is one of the most versatile trailers on the market. Sitting on a solid square tube cambered axle with 12-inch, 6-ply bias tires and a load capacity of 1,639 pounds. When the front and back load-bearing gates are down, the trailer bed extends to nearly 12 feet in length, and the tilt/dump capability that makes it easy to load or unload heavy items. Fabricated from 100% steel, all of the components are reinforced, adjustable, removable and/or interchangeable.

### SPECIFICATION

<b>PAYLOAD CAPACITY</b>	1,639lb (743.4kg)
<b>GVWR</b>	2,090lb (948kg)
<b>WHEELS &amp; TIRES</b>	D.O.T. 5.30-12 6-ply radial tire with 5 x 4.5" (11.4cm) bolt pattern
<b>MATERIAL</b>	Fully welded heavy-duty UV powder coated tubular steel
<b>SIDE PANELS</b>	Corrugated reinforced steel
<b>DROP GATES</b>	24" (61cm) load-bearing corrugated reinforced steel
<b>FLOORING</b>	Corrugated reinforced steel panel
<b>DUMP BED</b>	2-position, axle-mounted with quick-release lock pin
<b>LIGHTING</b>	Pre-wired, quick-connect D.O.T LED
<b>BED DIMENSIONS</b>	88" (L) x 52" (W) 223.5cm (L) x 132.1cm (W)
<b>FLOOR HEIGHT</b>	20" (50.8cm)
<b>HITCH HEIGHT</b>	16" (40.6cm)
<b>DIMENSIONS</b>	177" (L) x 65" (W) x 36" (H) 449.6cm (L) x 165.1cm (W) x 91.4cm (H)
<b>WEIGHT</b>	451lb (204.6kg)
<b>SHIPPING DIMENSIONS</b>	88" (L) x 55" (W) x 9" (H) 223.5cm (L) x 139.7cm (W) x 22.9cm (H)
<b>SHIPPING WEIGHT</b>	460lb (208.7kg)
<b>WARRANTY</b>	1-year limited



### FEATURES

- Constructed with fully welded heavy-duty hot-dipped galvanized tubular steel
- Corrugated reinforced steel floor panel **1**
- Corrugated reinforced steel side panels **2**
- 24" (61cm) load-bearing corrugated steel drop gates, extending the length of the trailer to 11.3ft (3.4m) **3**
- Solid square tube cambered axle
- 2-position axle-mounted dump bed with quick release lock pin **4**
- D.O.T. 5.30-12 radial tires with 5 x 4.5" (11.4cm) bolt pattern **5**
- Heavy-duty tail light protectors
- Quick-connect D.O.T. LED lighting with side markers
- Ships in a single package
- 2" (5.08cm) coupler on an A-frame tongue for added stability
- Includes all necessary paperwork for registration

## 5-IN-1 UTILITY TRAILER

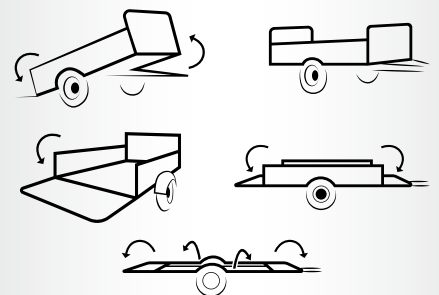

## 4.5FT x 7.5FT SINGLE AXLE MULTI-UTILITY GALVANIZED TRAILER WITH DRIVE-UP GATE

### ITEM NUMBER

MMT5X7G-DUG

59

### UPC

826518005302



### DESCRIPTION

This single axle multi-utility trailer from DK2 is one of the most versatile trailers on the market. Sitting on a solid square tube cambered axle with 12-inch, 6-ply bias tires and a load capacity of 1,639 pounds. Equipped with a 24-inch front load-bearing gate and a 40-inch rear drive-up gate, and a tilt/dump capability that makes it easy to load or unload heavy items. Fabricated from 100% hot-dipped galvanized steel, all of the components are reinforced, adjustable, removable and/or interchangeable.

### SPECIFICATION

<b>PAYLOAD CAPACITY</b>	1,639lb (743.4kg)
<b>GVWR</b>	2,090lb (948kg)
<b>WHEELS &amp; TIRES</b>	D.O.T. 5.30-12 6-ply radial tire with 5 x 4.5" (11.4cm) bolt pattern
<b>MATERIAL</b>	Fully welded heavy-duty hot-dipped galvanized tubular steel
<b>SIDE PANELS</b>	Corrugated reinforced steel
<b>GATES</b>	40" (101.6cm) expanded mesh and tubular steel rear ramp gate and 24" (61cm) load-bearing corrugated reinforced steel front gate
<b>FLOORING</b>	Corrugated reinforced steel panel
<b>DUMP BED</b>	2-position, axle-mounted with quick-release lock pin
<b>LIGHTING</b>	Pre-wired, quick-connect D.O.T LED
<b>BED DIMENSIONS</b>	88" (L) x 52" (W) 223.5cm (L) x 132.1cm (W)
<b>FLOOR HEIGHT</b>	20" (50.8cm)
<b>HITCH HEIGHT</b>	16" (40.6cm)
<b>DIMENSIONS</b>	177" (L) x 65" (W) x 36" (H) 449.6cm (L) x 165.1cm (W) x 91.4cm (H)
<b>WEIGHT</b>	451lb (204.6kg)
<b>SHIPPING DIMENSIONS</b>	88" (L) x 55" (W) x 9" (H) 223.5cm (L) x 139.7cm (W) x 22.9cm (H)
<b>SHIPPING WEIGHT</b>	460lb (208.7kg)
<b>WARRANTY</b>	1-year limited



### FEATURES

- Constructed with fully welded heavy-duty hot-dipped galvanized tubular steel
- Corrugated reinforced steel floor panel **1**
- Corrugated reinforced steel side panels **2**
- 40" (101.6cm) expanded mesh and tubular steel rear ramp gate **3**
- 24" (61cm) load-bearing corrugated steel front drop gate
- Solid square tube cambered axle
- 2-position axle-mounted dump bed with quick release lock pin **4**
- D.O.T. 5.30-12 radial tires with 5 x 4.5" (11.4cm) bolt pattern **5**
- Heavy-duty tail light protectors
- Quick-connect D.O.T. LED lighting with side markers
- Ships in a single package
- 2" (5.08cm) coupler on an A-frame tongue for added stability
- Includes all necessary paperwork for registration

## 5-IN-1 UTILITY TRAILER

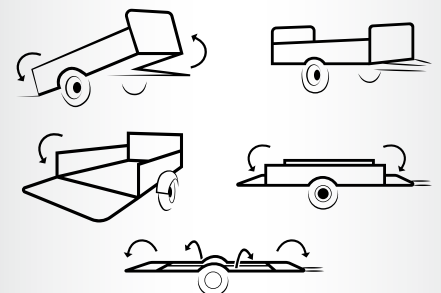

## 5FT x 8FT SINGLE AXLE UTILITY TRAILER

60



### ITEM NUMBER

MMT5X8

### UPC

XXXXXXXXXXXX

### DESCRIPTION

This single axle utility trailer from DK2 is built strong, sitting on a solid square tube cambered axle with 13-inch, D.O.T. approved tires and a load capacity of 1,650 pounds. Tow with added security and balance with its A-frame tongue, and load/unload with ease using its landscape ramp gate and tilt/dump capability. Fabricated from 100% steel.



### FEATURES

- Constructed with fully welded heavy-duty UV powder-coated tubular steel **1**
- Steel mesh or 2" x 8" pressure treated wood floor options available
- Open rail design **2**
- A-frame tongue with a 2" ball/coupler rated for 3,500lb on a Class II hitch **3**
- Solid square tube cambered axle
- 2-position axle-mounted dump bed with quick release lock pin
- D.O.T. approved ST175/80R13 13" tubeless tires **4**
- Heavy-duty tail light protectors
- D.O.T. approved lighting
- Includes all necessary paperwork for registration

### SPECIFICATION

<b>PAYLOAD CAPACITY</b>	1,650lb
<b>GVWR</b>	2,120lb
<b>TIRES</b>	ST175/80R13 13" tubeless
<b>MATERIAL</b>	Fully welded heavy-duty UV powder coated tubular steel
<b>SIDE RAILS</b>	Tubular steel
<b>RAMP GATE</b>	Included
<b>FLOORING</b>	Steel mesh or wood floor options available
<b>DUMP BED</b>	2-position, axle-mounted with quick-release lock pin
<b>LIGHTING</b>	D.O.T. approved
<b>BED DIMENSIONS</b>	96" (L) x 60" (W)
<b>BALL/COUPLER SIZE</b>	2"
<b>COUPLER CAPACITY</b>	Class II: 3,500lb max gross load
<b>WEIGHT</b>	470lb
<b>WARRANTY</b>	1-year limited



## 6FT x 10FT SINGLE AXLE OPEN RAIL UTILITY TRAILER

### ITEM NUMBER

MMT6X10

61

### UPC

826518005593



### DESCRIPTION

Introducing the new MMT6X10 single axle open rail utility trailer, the largest in DK2's collection. Constructed with fully welded heavy-duty powder-coated tubular steel with a corrugated steel panel floor, you can count on this trailer to deliver long lasting reliability for all your hauling needs. It has a payload capacity of 1,950 pounds and sits on a solid square tube cambered axle equipped with D.O.T. 14-inch 175/80R14 tires. Load and unload this trailer with ease using the included 48-inch drive-up gate.

### SPECIFICATION

<b>PAYLOAD CAPACITY</b>	1,950lb (884.5kg)
<b>GVWR</b>	2,500lb (1,134kg)
<b>WHEELS &amp; TIRES</b>	14" (35.6cm) D.O.T. 175/80R14 bias tires
<b>MATERIAL</b>	Fully welded heavy-duty UV powder coated tubular steel
<b>SIDE PANELS</b>	Open design, tubular steel
<b>GATE</b>	49.3" (125.2cm) tubular and expanded mesh steel ramp
<b>FLOORING</b>	Corrugated reinforced steel panels
<b>DUMP BED</b>	2-position, axle-mounted with quick-release lock pin
<b>LIGHTING</b>	Pre-wired, quick-connect D.O.T LED
<b>BED DIMENSIONS</b>	120" (L) x 72" (W) 304.8cm (L) x 182.9cm (W)
<b>FLOOR HEIGHT</b>	20.2" (51.3cm)
<b>HITCH HEIGHT</b>	18.2" (46.2cm)
<b>DIMENSIONS</b>	166.1" (L) x 83.9" (W) x 71.1" (H) 421.9cm (L) x 213.1cm (W) x 180.6cm (H)
<b>WEIGHT</b>	640lb (290.3kg)
<b>SHIPPING DIMENSIONS</b>	83.1" (L) x 74" (W) x 10.2" (H) 211.1cm (L) x 188cm (W) x 25.9cm (H)
<b>SHIPPING WEIGHT</b>	650.4lb (295kg)
<b>WARRANTY</b>	1-year limited

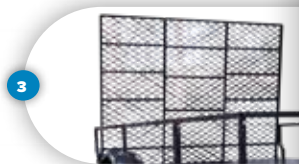

### FEATURES

- Constructed with fully welded heavy-duty UV powder-coated tubular steel
- Corrugated reinforced steel floor panel **1**
- Tubular steel open rail design **2**
- 49.3" (125.2cm) tubular and expanded mesh steel rear ramp gate **3**
- Solid square tube cambered axle
- 2-position axle-mounted dump bed with quick release lock pin **4**
- 14" (35.6cm) D.O.T. 175/80R14 bias tires **5**
- Heavy-duty tail light protectors
- Quick-connect D.O.T. LED lighting with side markers
- Ships in a single package
- 2" (5.08cm) coupler on an A-frame tongue for added stability
- Includes all necessary paperwork for registration

## 1100 LB POLY ATV TRAILER

62



### ITEM NUMBER

MMTATV

### UPC

827518008508

### DESCRIPTION

Looking for a durable ATV trailer that can handle any terrain? Look no further than the MMTATV 1100 lb ATV Trailer. With a massive capacity of 1100lbs, you can easily transport heavy loads wherever you need to go. Made from high-quality poly and steel frame, this trailer is built to last.

The 18-inch tires provide excellent traction and stability, while the 11.8-inch hitch height and 16.5-inch trailer to ground clearance make it easy to attach to your lawn tractor or ATV. The large bucket on this trailer ensures that you have plenty of space to transport your equipment or material.

With the MMTATV 1100 lb ATV Trailer, you can transport your equipment with ease and get the job done.

### FEATURES

- Constructed with high-quality poly and steel **1**
- Easily transport heavy loads with the 1,100 lb carrying capacity
- Take your trailer wherever you need to go with its 18" tires, providing excellent traction and stability **2**
- The 11.8" hitch height and 16.5" trailer to ground clearance make it easy to attach to your lawn tractor or ATV **3**
- The large bucket ensures plenty of space to transport equipment or material around the job site **4**
- Includes 1-year limited DK2 warranty

### SPECIFICATION

**PAYLOAD CAPACITY** 1,100 lb (499 kg)

**TIRES** 18" (45.7 cm)

**MATERIAL** High-quality poly bucket and steel frame

**DUMP BED** 2-position with quick-release pin

**BED DIMENSIONS** 96" (L) x 60" (W)

**BALL/COUPLER SIZE** 2" (5.08 cm)

**DIMENSIONS** 64.2" (L) x 46.3" (W) x 29.3" (H)  
163 cm (L) x 117.5 cm (W) x 74.5 cm (H)

**WEIGHT** 103.6 lb (47 kg)

**WARRANTY** 1-year limited



# **DIAMANT® ACCESSORIES**







## TRUNK MOUNTED ALUMINUM 3-BIKE CARRIER

### ITEM NUMBER

BCR190

### UPC

827518007129

66



### DESCRIPTION

Just because you don't have a receiver hitch on your vehicle doesn't mean you can't take your bikes with you. The DK2 BCR190 can be strapped to the trunk of a car or small SUV using its heavy-duty durable nylon straps and haul up to 3 bikes without damaging the paint or body of the vehicle using the carrier's foam frame pads.

This bicycle carrier is adjustable for most makes and model of vehicles and easy to assemble. Soft rubber cradles and straps allow you to secure the bikes to the carrier without damaging the finish or performance of the bicycles, and the lightweight aluminum construction allows for easy installation or removal to/from the vehicle.

### SPECIFICATION

<b>PAYLOAD CAPACITY</b>	70lb (31.8kg) (2 bikes) 81lb (36.7kg) (3 bikes)
<b>MATERIAL</b>	UV and temperature resistant lightweight aluminum
<b>MOUNTING STRAPS</b>	Heavy-duty durable nylon
<b>CRADLES</b>	Soft rubber
<b>CRADLE STRAPS</b>	Adjustable rubber
<b>COMPATIBILITY</b>	Mountain bikes and road bikes
<b>MOUNT STYLE</b>	Trunk-mounted
<b>DIMENSIONS</b>	29" (L) x 18" (W) x 29" (H) 73.7cm (L) x 45.7cm (W) x 73.7cm (H)
<b>WEIGHT</b>	8lb (3.6kg)
<b>SHIPPING DIMENSIONS</b>	19.5" (L) x 34" (W) x 6" (H) 48.3cm (L) x 86.4cm (W) x 15.2cm (H)
<b>SHIPPING WEIGHT</b>	11lb (5kg)
<b>WARRANTY</b>	1-year limited



### FEATURES

- UV and extreme temperature resistant lightweight aluminum construction **1**
- Mounts to the trunk of most cars or small SUV's with heavy-duty durable nylon mounting straps **2**
- Carries up to three bicycles with 2 rubber cradles and adjustable straps per bicycle **3**
- Folding adjusters to fold the rack away when not in use **4**
- Foam frame pads to prevent vehicle scratching **5**
- 1-year limited warranty
- **DO NOT MOUNT TO RVs, TRAVEL TRAILERS, OR ANY MID-AXLE VEHICLES**



## HITCH MOUNTED 4-BIKE CARRIER

### ITEM NUMBER

BCR290

67

### UPC

827518007136



### DESCRIPTION

The DK2 BCR290 hitch-mounted bike carrier is the perfect way to transport bikes for long road trips.

Quick and easy assembly takes only minutes and this carrier is constructed with UV power-coated steel to resist damage from harsh weather conditions.

Simply slide the bike carrier into your 2-inch receiver hitch and secure using the anti-wobble hitch pin. No-mark straps allow you to secure up to 4 bicycles to your carrier for transportation, and when out of use, the carrier tilts away for easy access to the rear of the mounted-vehicle.

### SPECIFICATION

<b>PAYLOAD CAPACITY</b>	200lb (90.7kg) (Class III or IV receiver recommended)
<b>MATERIAL</b>	UV powder-coated steel
<b>CRADLES</b>	Soft rubber
<b>CRADLE STRAPS</b>	Adjustable rubber
<b>COMPATIBILITY</b>	Mountain bikes and road bikes
<b>MOUNT STYLE</b>	2" (5.08cm) hitch-mounted (Class III or IV receiver recommended)
<b>DIMENSIONS</b>	35" (L) x 12" (W) x 35" (H) 88.9cm (L) x 30.5cm (W) x 88.9cm (H)
<b>WEIGHT</b>	20lb (9.1kg)
<b>SHIPPING DIMENSIONS</b>	22.5" (L) x 14" (W) x 3.75" (H) 57.2cm (L) x 35.6cm (W) x 9.5cm (H)
<b>SHIPPING WEIGHT</b>	23.2lb (10.5kg)
<b>WARRANTY</b>	1-year limited



### FEATURES

- Heavy-duty UV powder-coated steel construction **1**
- Mounts to any 2" (5.08cm) hitch receiver and carries up to 200lb (90.7kg) with a class III or IV receiver **2**
- Carries up to four bicycles with 2 rubber cradles **3** and adjustable straps **4** per bicycle
- Folding adjusters to fold the rack away when not in use for easy rear-vehicle access **5**
- 1-year limited warranty
- **DO NOT MOUNT TO RVs, TRAVEL TRAILERS, OR ANY MID-AXLE VEHICLES**



## HITCH-MOUNTED 2-BIKE PLATFORM CARRIER

### ITEM NUMBER

BCR590

### UPC

827518007112

68



### DESCRIPTION

The DK2 BCR590 hitch-mounted platform bike carrier fits into either a 1.25-inch or 2-inch receiver hitch and allows for the easy transportation of two bicycles totalling up to 80 pounds by securing them to carrier.

The BCR590 adjusts in width and height to fit your bike while making sure the no-mark straps don't damage the finish of the mounted bike. This carrier folds up when not in use and the center arm folds down to allow access to the rear of the vehicle without removing the rack.

Lightweight and easy to assemble, the BCR590 is the perfect solution for those long road trips.

### SPECIFICATION

<b>PAYLOAD CAPACITY</b>	80lb (36.3kg) (Class III or IV receiver recommended)
<b>MATERIAL</b>	UV powder-coated steel
<b>FRAME CRADLES</b>	Steel with no-mark padding and height adjustability
<b>WHEEL CRADLES</b>	Steel with length adjustability
<b>WHEEL CRADLE STRAPS</b>	Adjustable rubber
<b>COMPATIBILITY</b>	Mountain bikes and road bikes
<b>MOUNT STYLE</b>	1.25" (3.18cm) / 2" (5.08cm) hitch-mounted (Class III or IV receiver recommended)
<b>DIMENSIONS</b>	53" (L) x 39" (W) x 20" (H) 134.6cm (L) x 99.1cm (W) x 50.8cm (H)
<b>WEIGHT</b>	28lb (12.7kg)
<b>SHIPPING DIMENSIONS</b>	40" (L) x 10.5" (W) x 5.5" (H) 101.6cm (L) x 26.7cm (W) x 14cm (H)
<b>SHIPPING WEIGHT</b>	30lb (13.6kg)
<b>WARRANTY</b>	1-year limited



### FEATURES

- Heavy-duty UV powder-coated steel construction **1**
- Mounts to any 1.25" (3.18cm) or 2" (5.08cm) hitch receiver and carries up to 80lb (36.3kg) with a class III or IV receiver **2**
- Carries up to two bicycles with 2 length-adjustable steel wheel cradles with adjustable rubber straps **3** and height-adjustable, no-mark frame cradles **4** per bicycle
- Folding adjusters to fold the rack away when not in use **5**
- 1-year limited warranty
- **DO NOT MOUNT TO RVs, TRAVEL TRAILERS, OR ANY MID-AXLE VEHICLES**



## HITCH-MOUNTED E-BIKE PLATFORM HAULER

### ITEM NUMBER

BCR690E

69

### UPC

827518008003

### DESCRIPTION

Built to conveniently load two bikes of any size with its large wheel cradles, convenient rear wheel stubber straps, and padded universal frame cradles, you and a friend or family member can ride off-road, in the city, or wherever your journey takes you with the BCR690E E-bike hauler.

With effortless loading capabilities, a revolutionary pivot feature that gives you access to your tailgate or hatchback, and easy mounting with its 2-inch hitch compatibility, your only concern will be where to go next.

### SPECIFICATION

<b>PAYLOAD CAPACITY</b>	72.3lb (32.8kg) (1 bike) 144.6lb (65.6kg) (2 bikes) (Class III or IV receiver recommended)
<b>MATERIAL</b>	UV powder-coated steel
<b>FRAME CRADLES</b>	Steel with no-mark padding and height adjustability
<b>FRONT WHEEL CRADLES</b>	Large, heavy-duty poly
<b>REAR WHEEL CRADLES</b>	Length-adjustable, heavy-duty poly with adjustable rubber straps
<b>COMPATIBILITY</b>	E-bikes, fat tire bikes, mountain bikes, and road bikes
<b>MOUNT STYLE</b>	2" (5.08cm) hitch-mounted (Class III or IV receiver recommended)
<b>DIMENSIONS</b>	61.8" (L) x 43.3" (W) x 33" (H) 157cm (L) x 110cm (W) x 83.8cm (H)
<b>WEIGHT</b>	44lb (20kg)
<b>SHIPPING DIMENSIONS</b>	53.5" (L) x 12.2" (W) x 9.8" (H) 135.9cm (L) x 31cm (W) x 24.9cm (H)
<b>SHIPPING WEIGHT</b>	52lb (23.6kg)
<b>WARRANTY</b>	1-year limited

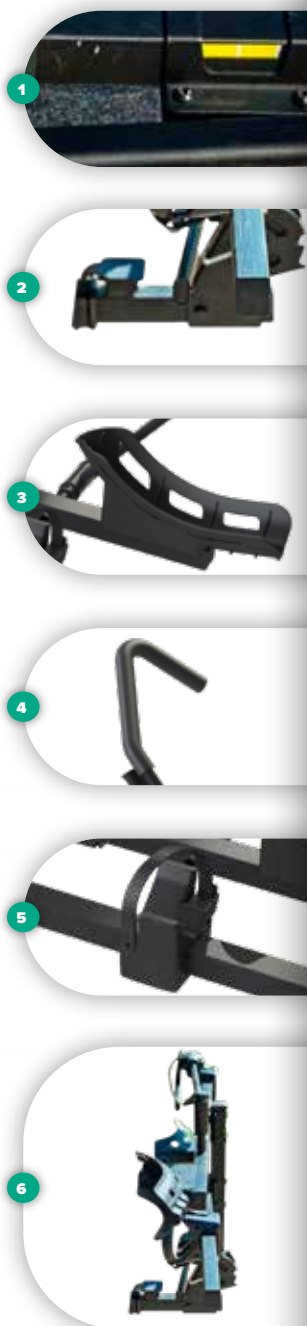

### FEATURES

- Heavy-duty UV powder-coated steel construction **1**
- Mounts to any 2" (5.08cm) hitch receiver and carries up to 144.6lb (65.6kg) with a class III or IV receiver **2**
- Large, heavy-duty poly front wheel cradles **3**
- Height-adjustable, no-mark padded frame cradles **4**
- Length-adjustable, heavy-duty poly rear wheel cradles with adjustable rubber straps **5**
- Folding adjusters to fold the rack away when not in use **6**
- 1-year limited warranty
- **DO NOT MOUNT TO RVs, TRAVEL TRAILERS, OR ANY MID-AXLE VEHICLES**



## HEAVY DUTY HITCH-MOUNTED E-BIKE PLATFORM HAULER

### ITEM NUMBER

BCR790E

### UPC

827518009468

70



### DESCRIPTION

Built to conveniently load two bikes of any size with its large wheel cradles, convenient rear wheel stubber straps, and padded universal frame cradles, you and a friend or family member can ride off-road, in the city, or wherever your journey takes you with the BCR790E Heavy Duty E-bike hauler.

With effortless loading capabilities, a revolutionary pivot feature that gives you access to your tailgate or hatchback, integrated bike ramp for easy loading its 2-inch hitch compatibility, your only concern will be where to go next.

### SPECIFICATION

<b>PAYLOAD CAPACITY</b>	77 lb (35 kg) (1 bike) 154 lb (70 kg) (2 bikes) (Class III or IV receiver recommended)
<b>MATERIAL</b>	UV powder-coated steel
<b>FRONT WHEEL CRADLES</b>	Large, heavy-duty poly
<b>REAR WHEEL CRADLES</b>	Length-adjustable, heavy-duty poly with adjustable rubber straps
<b>TIRE SIZE COMPATIBILITY</b>	15.9" to 28.9" (40.6 cm to 73.6 cm)
<b>MAX TIRE WIDTH</b>	4.7" (12.1 cm)
<b>COMPATIBILITY</b>	E-bikes, fat tire bikes, mountain bikes, and road bikes
<b>MOUNT STYLE</b>	2" (5.08 cm) hitch-mounted (Class III or IV receiver recommended)
<b>FOLDED DIMENSIONS</b>	58.6" (L) x 17.8" (W) x 32.3" (H) 148.8 cm (L) x 45.2 cm (W) x 82.1 cm (H)
<b>UNFOLDED DIMENSIONS</b>	58.6" (L) x 41.8" (W) x 38.2" (H) 148.8 cm (L) x 106.2 cm (W) x 97.1 cm (H)
<b>WEIGHT</b>	61.7 lb (28 kg)
<b>SHIPPING DIMENSIONS</b>	55.1" (L) x 18.1" (W) x 9.8" (H) 140 cm (L) x 46 cm (W) x 25 cm (H)
<b>SHIPPING WEIGHT</b>	68.3 lb (31 kg)
<b>WARRANTY</b>	1-year limited



### FEATURES

- Heavy-duty UV powder-coated steel construction **1**
- Mounts to any 2" (5.08cm) hitch receiver and carries 1 bike up to 77 lb (35 kg) or 2 bikes up to 154 lb (70 kg) with a class III or IV receiver **2**
- Carries up to two bicycles with 2 length-adjustable steel wheel cradles with adjustable rubber straps **3** and height-adjustable frame cradles
- Easy tilt control handle, just pull and lift when not in use **4**
- Integrated removable bike ramp for easy loading and unloading **5**
- 1-year limited warranty
- **DO NOT MOUNT TO RVs, TRAVEL TRAILERS, OR ANY MID-AXLE VEHICLES**

## HITCH-MOUNTED STEEL CARGO CARRIER

### ITEM NUMBER

HCC602

71

### UPC

827518001165



### DESCRIPTION

The DK2 hitch-mounted black powder coated steel cargo carrier allows you to immediately increase the cargo capacity of your vehicle so you can haul bulky, messy items like luggage, coolers or firewood.

This carrier has a 500 pound payload capacity (with a Class III or IV hitch receiver) and flips up against your vehicle when not in use.



### SPECIFICATION

<b>PAYLOAD CAPACITY</b>	500lb (226.8kg) (with class III or IV hitch receiver)
<b>MATERIAL</b>	Heavy-duty UV powder-coated tubular and expanded mesh steel
<b>MOUNT STYLE</b>	Hitch-mounted
<b>DIMENSIONS</b>	60" (L) x 20" (W) x 6.5" (H) 152.4cm (L) x 50.8cm (W) x 16.5cm (H)
<b>WEIGHT</b>	47lb (21.3kg)
<b>SHIPPING DIMENSIONS</b>	33" (L) x 22" (W) x 10" (H) 83.8cm (L) x 55.9cm (W) x 25.4cm (H)
<b>SHIPPING WEIGHT</b>	51lb (23.1kg)
<b>WARRANTY</b>	Limited 1-year



### FEATURES

- Heavy duty UV powder-coated tubular and expanded mesh steel construction
- Mounts to any 2" (5.08cm) hitch receiver **1**
- Flips up when not in use and stows against the rear of the vehicle **2**
- Carries up to 500lb (226.8kg) dependent on receiver strength (recommended Class III or IV)
- 3 rear reflective markers for additional road safety **3**
- **DO NOT MOUNT TO RVs, TRAVEL TRAILERS, OR ANY MID-AXLE VEHICLES**

## HITCH-MOUNTED ALUMINUM CARGO CARRIER

### ITEM NUMBER

HCC502A

### UPC

826518005050

### FEATURES

- Durable and lightweight aluminum construction
- Mounts to any 2" (5.08cm) hitch receiver **1**
- Flips up when not in use and stows against the rear of the vehicle **2**
- Carries up to 500lb (226.8kg) dependent on receiver strength (recommended Class III or IV receiver)
- Includes threaded anti-wobble hitch pin for added stability
- 11 rear reflective markers for additional road safety **3**
- **DO NOT MOUNT TO RVs, TRAVEL TRAILERS, OR ANY MID-AXLE VEHICLES**

### DESCRIPTION

The DK2 hitch-mounted aluminum cargo carrier allows you to immediately increase the cargo capacity of your vehicle so you can haul bulky, messy items like luggage, coolers or firewood.

This carrier has a 500 pound payload capacity (with a Class III or IV hitch receiver) and flips up against your vehicle when not in use.



### SPECIFICATION

**PAYLOAD CAPACITY** 500lb (226.8kg)  
(with class III or IV hitch receiver)

**MATERIAL** Lightweight aluminum, formed steel hitch and hitch bracket, carbon steel hardware, thermoplastic end caps

**MOUNT STYLE** Hitch-mounted

**DIMENSIONS** 49.5" (L) x 22.25" (W) x 6.5" (H)  
125.7cm (L) x 56.5cm (W) x 16.5cm (H)

**WEIGHT** 29lb (13.2kg)

**SHIPPING DIMENSIONS** 50" (L) x 24" (W) x 4" (H)  
127cm (L) x 61cm (W) x 10.2cm (H)

**SHIPPING WEIGHT** 32lb (14.5kg)

**WARRANTY** Limited 1-year





## HITCH-MOUNTED MOTORCYCLE CARRIER

### ITEM NUMBER

TMC201

73

### UPC

693495970561



### DESCRIPTION

For someone who doesn't want the hassles associated with towing a trailer, the hitch-mounted motorcycle carrier is the perfect option for you.

Since this carrier utilizes our patent-pending WedgeLock™ mounting system, it is rock solid and will keep your bike stable and secure. Now you can transport your bike with confidence and ease. This carrier works equally great with motorcycles, motocross & dual purpose bikes, scooters and mopeds.

### SPECIFICATION

<b>MATERIAL</b>	UV powder coated steel
<b>MOUNT STYLE</b>	Hitch-mounted
<b>DIMENSIONS</b>	55" (L) x 21" (W) x 7" (H) 139.7 cm (L) x 53.3 cm (W) x 17.8 cm (H)
<b>WEIGHT</b>	86 lb (39 kg)
<b>SHIPPING DIMENSIONS</b>	56" (L) x 21" (W) x 7" (H) 142.2 cm (L) x 53.3 cm (W) x 17.8 cm (H)
<b>SHIPPING WEIGHT</b>	89 lb (40.4 kg)
<b>WARRANTY</b>	Limited 1-year

VEHICLE HITCH MANUFACTURER RATING	MAXIMUM CARRYING CAPACITY
300 lb (136.1 kg)	180 lb (81.6 kg)
350 lb (158.8 kg)	225 lb (102.1 kg)
500 lb (226.8 kg)	350 lb (158.8 kg)
750 lb (340.2 kg)	500 lb (226.8 kg)



### FEATURES

- Extremely versatile, secure and stable: patent-pending design results in a snug anti-wobble fit
- Tilts down for easy loading and unloading **1**
- Easily installed and removed - no extra tools required
- Ideally suited for SUVs or pickup trucks
- Features adjustable front wheel channel to accommodate different sized bikes **2**
- Retractable tie-down bar
- Safety chains and hitch pin included
- Fits any standard 2 inch class III or IV hitch receiver (weight capacity dependent on receiver strength) **3**
- UV-Powder coated steel construction
- **DO NOT MOUNT TO RVs, TRAVEL TRAILERS, OR ANY MID-AXLE VEHICLES**





2022/2023

# PRODUCT CATALOG