

SPORTS AFIELD®

Established 1887



HOME DEFENSE

**QUICK ACCESS BIOMETRIC SECURITY VAULTS
INSTRUCTION MANUAL FOR SA-HD2-BIO & SA-HD3-BIO**



**BIOMETRIC
[SECURE ENTRY]**

TABLE OF CONTENTS

<i>IMPORTANT INFORMATION</i>	2
<i>1. REGISTRATION</i>	3
<i>2. UNDERSTANDING YOUR VAULT</i>	4
<i>3. INITIAL ENTRY</i>	5
<i>4. BATTERY INSTALLATION</i>	6
<i>5. PROGRAMMING YOUR FINGERPRINT</i>	6
<i>6. OPENING VAULT WITH PROGRAMMED FINGERPRINT</i>	7
<i>7. PROGRAMMING ADDITIONAL FINGERPRINTS</i>	8
<i>8. TROUBLE SHOOTING</i>	9
<i>9. LOCKOUT MODE /TAMPER PROTECTION</i>	10
<i>10. SILENT ENTRY MODE</i>	10
<i>11. CLEARING ALL PROGRAMMED FINGERPRINTS</i>	10
<i>12. PROPER PLACEMENT AND MOVING OF VAULT</i>	11
<i>13. SECURING YOUR VAULT</i>	11
<i>14. LOADING YOUR VAULT</i>	13
<i>15. MAINTAINING HINGES AND INTERNAL MECHANISMS</i>	13
<i>WARRANTY</i>	14

DISCLAIMER - READ BEFORE VAULT SETUP

PLEASE READ THIS INFORMATION CAREFULLY BEFORE OPERATING YOUR SPORTS AFIELD VAULT.

DO NOT LOCK THIS MANUAL OR THE OVERRIDE ACCESS KEYS IN YOUR VAULT.

- Thank you for choosing a Sports Afield vault to protect your valuables. We are committed to securing, organizing and protecting your most important documents, valuables and keepsakes.
- If you experience problems or challenges with your vault, please contact us. Many issues can be quickly resolved without the product being returned.

Contact Customer Service at cs@saproducts.com or (888) 792-4264

SAFETY

- Be sure to keep backup keys stored in a safe place away from unauthorized users.
- Do not put anything in your vault that will put pressure against the door when it is closed.

WEAPON STORAGE

- If you choose to utilize this vault to store a weapon always follow proper weapon and local laws.
- SA Consumer Products strongly recommends that you do not store loaded guns.
- Always follow the firearm safety rules set out by the firearm's manufacturer.
- Store ammunition separately from valuables.
- A Sports Afield vault or any other firearm storage device cannot take the place of other safety procedures including advising children of the dangers of firearms.
- SA Consumer Products and its distributors of the Sports Afield vaults do not recommend, suggest, advise, promote, or otherwise condone the ownership or use of firearms. We believe the decision to own or use a firearm is a serious decision that should only be made by an adult who has carefully considered the risks and benefits of such a decision.

1. REGISTRATION

Register your vault at www.saproducts.com

By registering your Sports Afield vault we will be able to expedite and address any problems or challenges you may have which would otherwise require a notary letter and proof of payment.

REGISTRATION INFORMATION

The information you record onto this page will be required in the event you cannot access the contents of your Sports Afield vault. Please fill out all the required information below and retain for your records and safe keeping.

PLEASE HAVE THIS INFORMATION READY PRIOR TO CALLING FOR TECHNICAL ASSISTANCE AT:

Contact Customer Service at cs@saproducts.com or (888) 792-4264

PURCHASE DATE:

PURCHASE PRICE (BEFORE TAX):

MODEL NUMBER:

SERIAL NUMBER:

RETAILER NAME:

KEY NUMBER (IF APPLICABLE):

2. UNDERSTANDING YOUR VAULT

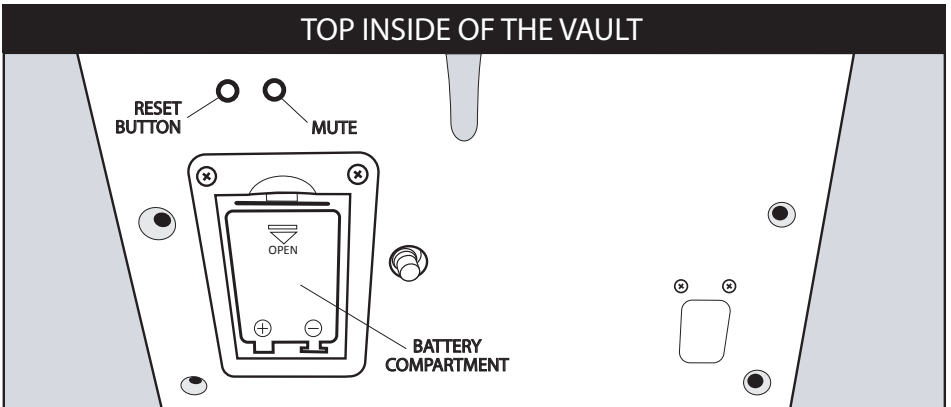
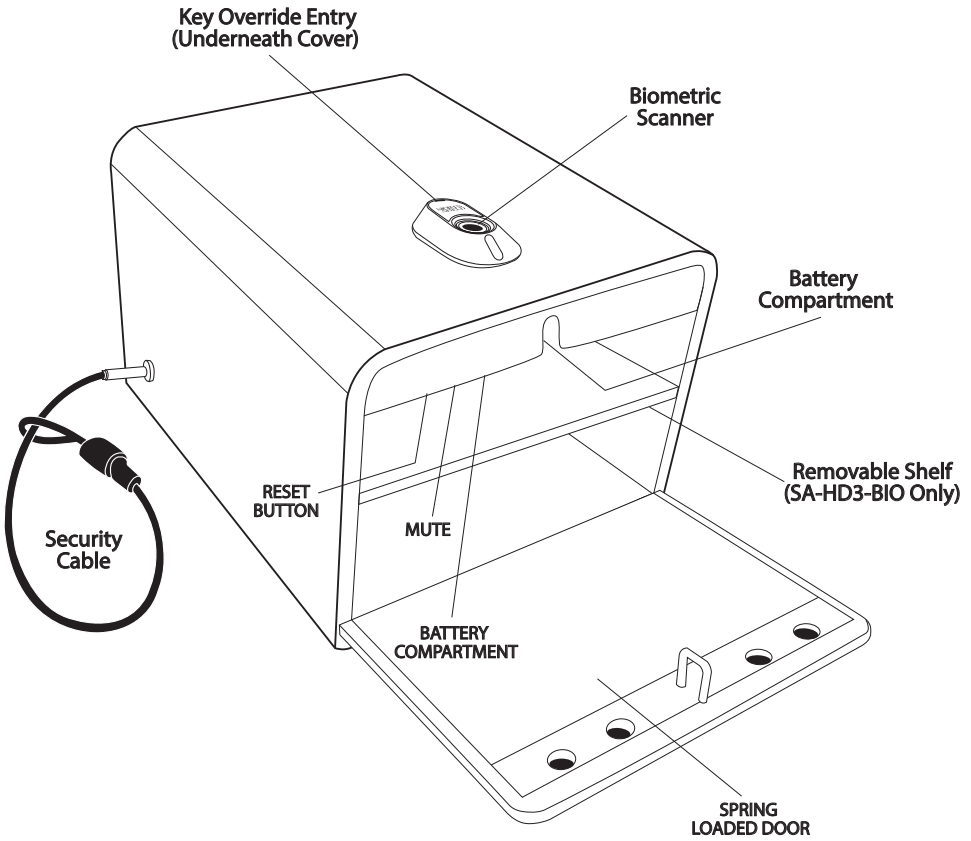

3. INITIAL ENTRY

1. Locate the override key attached to the product packaging. Remove the override key cover carefully by placing a flat end screw driver into the slot and pry it upwards.

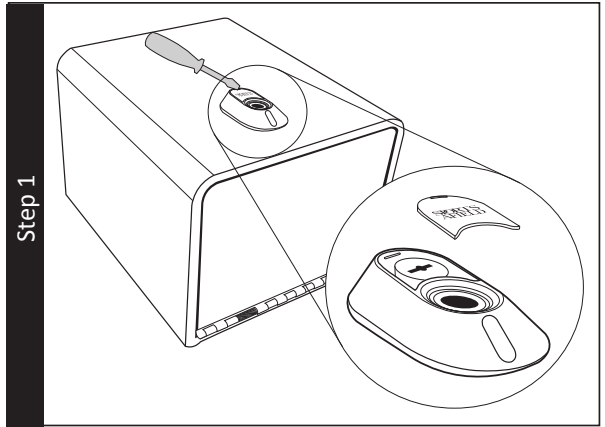

2. Turn the key clockwise to unlock your vault.

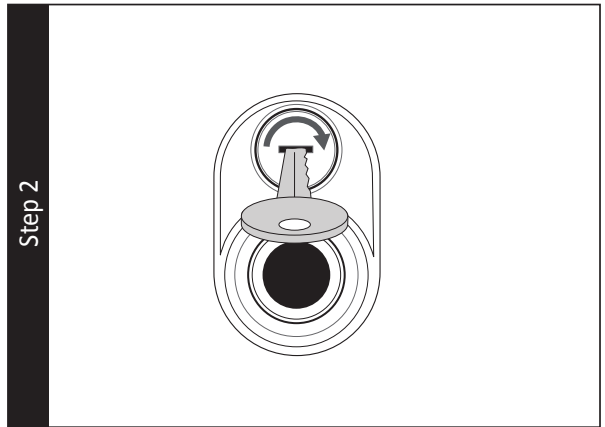

3. The spring loaded door will drop open and you now have access to your vault.

WARNING: BE SURE NOT TO PLACE VALUABLES OR HANDS IN FRONT OF DOOR AS THE FORCE OF THE DOOR OPENING DOWNWARD COULD CAUSE DAMAGE OR INJURY.

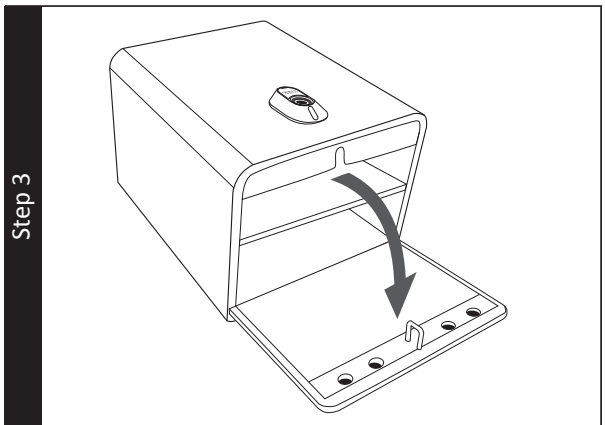

4. BATTERY INSTALLATION

WARNING: The battery must be inserted with the correct polarity. Exhausted battery must be removed from the product and discarded safely. Do not use rechargeable (nickel – cadmium) batteries.

1. Locate the battery compartment on the inside of the door panel. Insert the 9V battery in the proper orientation. Scanner will beep when the battery is successfully installed.

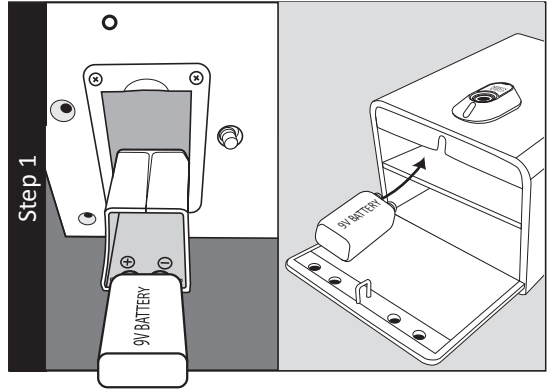

5. PROGRAMMING YOUR FINGERPRINT

1. Press and release the reset button. The scanner will beep once and the indicator ring will illuminate, indicating you are now programming more fingerprints. ***Keep vault lid open while programming new fingerprint***

NOTE: Programming mode will time out after 10 seconds of inactivity. If this occurs press reset button and begin again.

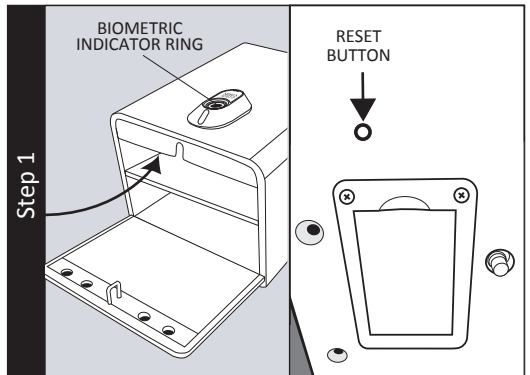

5. PROGRAMMING YOUR FINGERPRINT

2. **Place and hold** the pad of your finger on the scanner **until it flashes green and beeps one time.**

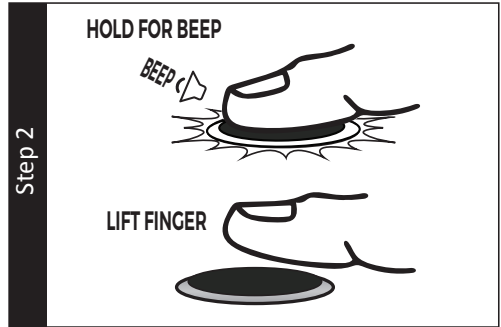

3. **Repeat** at least **3 more times** until there are **2 consecutive beeps** and **2 green flashes.**

⚠ IMPORTANT: Be sure to use the same area of the same finger for each recording sequence.

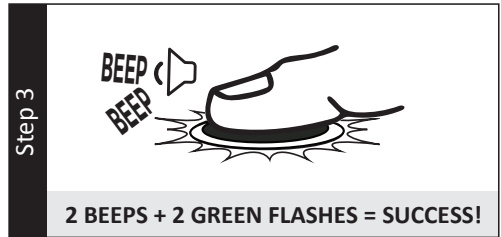

6. OPENING VAULT WITH PROGRAMMED FINGERPRINT

With keys in hand, close and lock the door.

Place and hold the **programmed** finger on the scanner, indicator ring will illuminate green and vault door will open automatically.



If your fingerprint is not accepted: If indicator ring will flash 1 time and sounds 1 time, the scanner did not read your fingerprint (try again).

⚠ IMPORTANT: If you see **5 red flashes** and the unit sounds **5 times**, the scanner read your fingerprint but did not accept it. Follow section 5 to reprogram your fingerprint.

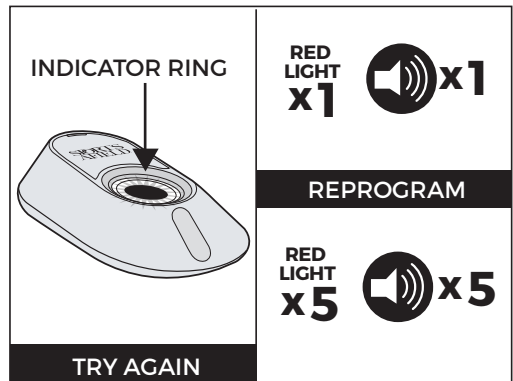

7. PROGRAMMING ADDITIONAL FINGERPRINTS

When accessing your vault quickly, there is a chance you may touch the scanner with a part of your finger that you have not registered before. For this reason, we recommend programming additional areas of your fingerprint to ensure fast and reliable entry to your vault.

INDIVIDUALLY MAPPING ALL ZONES OF YOUR FINGERPRINT WILL ENSURE A RELIABLE READING BY THE SCANNER.

To ensure each programming sequence is properly captured, it needs to read the exact same place on your finger four times in a row, once successful you can move onto the next zone of your fingerprint. This counts as one programmed fingerprint of 100 fingerprints this unit can keep in memory.

Once programming sequence has been successfully completed, you can move onto the next zone of your fingerprint.

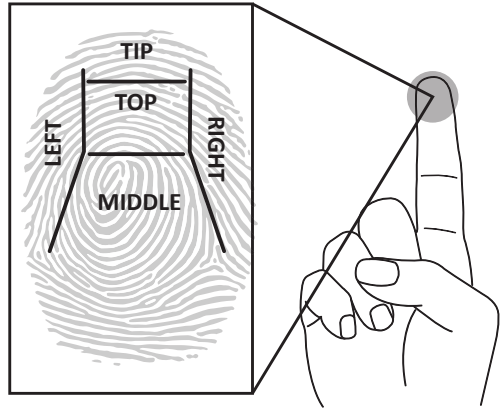

Press the reset button and follow Section 4 instructions again, for each fingerprint zone you would like to program.

If you experience any problems reading your fingerprint, including inconsistent readings, note the area of your fingerprint that doesn't work properly, and specifically re-program that area.

This scanner will hold up to 100 different fingerprints.

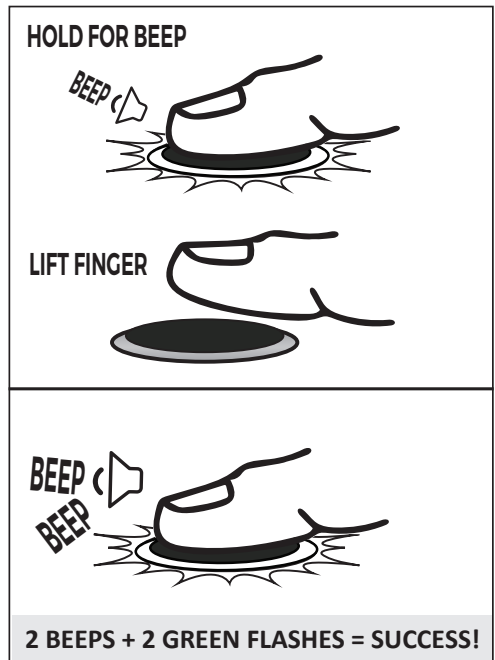

8. TROUBLE SHOOTING

In the event that you run into issues with programming and accessing your vault, please read through this section for answers to your questions.

Low Battery Indicator

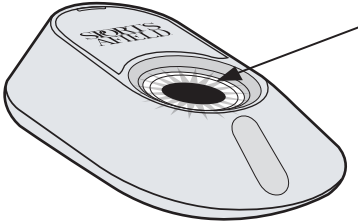

After an accepted fingerprint the scanner will illuminate and hold a beep for 3 seconds, signaling the vault is in low battery mode. Replace batteries immediately to avoid being locked out of your vault.

Locked Out Of Your Vault

In the event you are locked out your vault, use your backup keys to gain access and follow the section 3 Initial Entry instructions.

If you have lost your backup keys, or are still having any difficulties, contact customer service at the number below. Proof of purchase is required to obtain keys.

Contact Customer Service at cs@saproducts.com or (888) 792-4264

PROBLEM	SOLUTION
THE SCANNER IS NOT READING YOUR FINGERPRINT	Make sure to hold down your finger on the scanner instead of tapping. Scanner needs time to complete the scanning process.
	Fingerprints may lack definition due to excessive skin dryness. We recommend applying moisturizer or slide your fingerprint against your forehead before scanning process.
YOUR PROGRAMMED FINGERPRINT IS NOT READING AT ALL TIMES	Placing a portion of a fingerprint on the scanner that has not been programmed can result in an error. We recommend programming multiple areas of each fingerprint.

9. LOCKOUT MODE/TAMPER PROTECTION

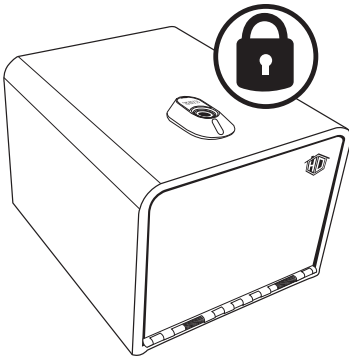

1. Three consecutive incorrect code entries will put the vault in “Basic Lockout” mode. Scanner is deactivated for 30 seconds.
2. After “Basic Lockout” mode has ended, another three consecutive incorrect code entries will result in “Severe Lockout” mode. Scanner is deactivated for 5-minutes.

10. SILENT ENTRY MODE

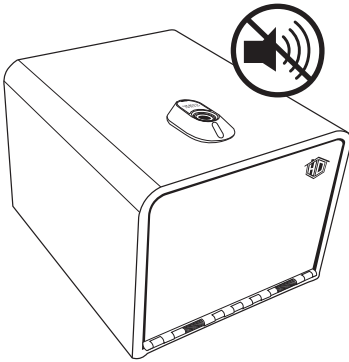

To initiate silent entry mode, hold a programmed finger on the scanner for 5 seconds beyond your fingerprint being accepted. The green indicator ring will turn off and back on, but will not beep, indicating you are now in silent entry mode.

You will not hear any sounds for any functions while the vault is in silent entry mode.

To turn the sound back on, hold a programmed finger on the scanner for 5 seconds beyond your fingerprint being accepted. The green indicator ring will turn off and back on and will beep once indicating you are no longer in silent entry mode.

11. CLEARING ALL PROGRAMMED FINGERPRINTS

Hold Reset button. Initially, the indicator ring will flash green and beep once. Continue holding reset button for 5 seconds, the indicator ring will flash green two times and beep two times.

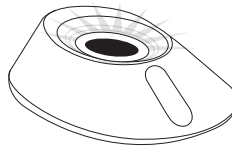

**GREEN
LIGHT
x2**



NOTE:

If 100 max fingerprints have already been programmed indicator ring will flash 5 times and beep 5 times. We recommend clearing all programmed fingerprints and starting the programming process over.

12. PROPER PLACEMENT AND MOVING OF VAULT

1. To maximize burglary protection and stability, securing the vault to the floor or wall is recommended.
2. SA Consumer Products recommends that you store your vault in a closet, office, basement, bedroom or any other location that is convenient for you but out of direct line of sight from prying eyes.
3. Always ensure the vault is in an isolated and dry area. Never place the vault in direct contact with a wet floor. When installing your vault on a concrete floor, use of a moisture/protective barrier is highly recommended. Failure to do so or exposing the vault to chemicals or other adverse environments may void the warranty.

13. SECURING YOUR VAULT

SECURING YOUR VAULT WITH PROVIDED CABLE

1. A security cable is included with your vault. To secure the cable around a fixed object, first loop the cable around the object as shown in the figure to the right.

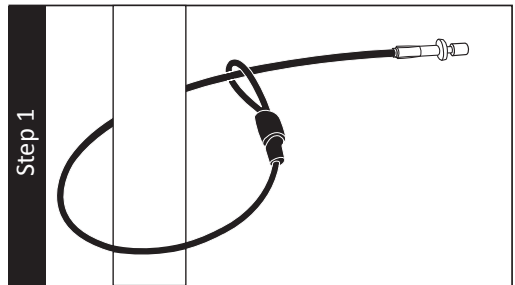

2. Insert the cable's metal peg end into the hole on the side of the vault while still open.
3. From the inside of the vault, take the cable clip and push it over the metal peg until fully secured. Use pliers if needed.

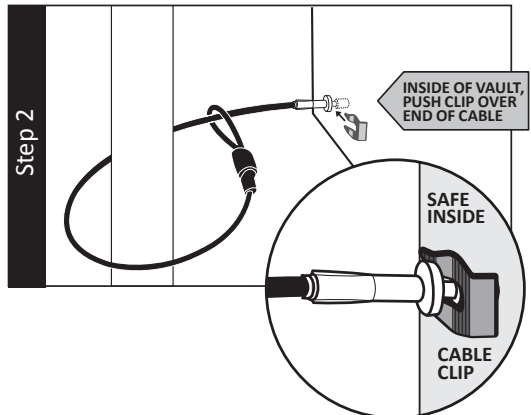

13. SECURING YOUR VAULT (CONTINUED)

TOOLS AND HARDWARE NEEDED TO SECURE VAULT TO A WOOD OR CONCRETE SURFACE:

- **DRILL**
- **3/8" DRILL BIT**
(FOR DRILLING ANCHOR HOLE)
or **3/16"** (FOR INSTALL W/ OUT ANCHOR)
- **SOCKET WRENCH TO MATCH BOLT HEAD SIZE**
- **2 STEEL LAG BOLTS (NOT INCLUDED)** - SIZE 1/4" X 1.50" TO 2.0" LONG
- **2 STEEL WASHERS (NOT INCLUDED)** - 1/4"
- **2 PLASTIC ANCHORS (NOT INCLUDED)**- SIZE #10-12 X 1.5" TO 1.75" LONG
(FOR CONCRETE INSTALLATION)
- **4 PADS (INCLUDED)**

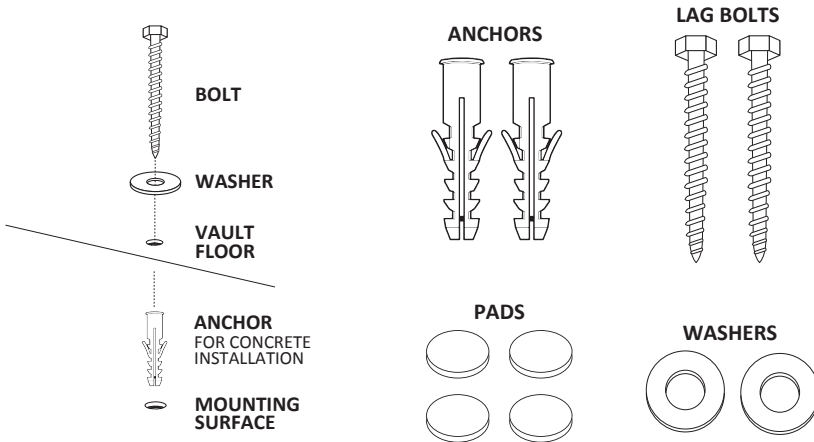

1. Use the recommended hardware or consult your hardware retailer for fastening hardware for your particular mounting surface.
2. Open the vault door to provide access to the factory drilled bolt down holes that are located under the protective foam liner.
3. To secure your vault to the floor, it will first be necessary to mark and drill pilot holes in the floor surface.
4. Drill the appropriate diameter and depth of pilot holes based on the type of hardware being used and the type of floor surface. When mounting on concrete we recommend using a hammer drill and a concrete drill bit to drill the two corresponding holes in the mounting surface.
5. Secure the vault by threading anchor bolts through the factory drilled bolt down holes in the vault and screw down tight with a ratchet wrench.

14. LOADING YOUR VAULT

1. Store ammunition separately from valuables.
2. Do not put anything in your vault that will put pressure against the door when it is closed.

15. MAINTAINING HINGES AND INTERNAL MECHANISMS

The hinges and internal locking mechanism are permanently lubricated, thus needing no maintenance. Opening the door panel of your vault may void your warranty. Always consult our customer service experts prior to doing so.

THREE YEAR WARRANTY

SA Consumer Products will repair or replace, at their sole discretion, any Sports Afield vault with defective parts, paint or lock for three years of the original owner purchase date.

If SA Consumer Products deems a replacement vault is to be sent, they will pay the freight costs to ship the replacement vault to the original owner.

This three year warranty is limited to the vault and expressly excludes any loss associated with the contents of the vault.

SA Consumer Products reserves the right to receive full evidence of your misfortune, such as a police report and/or homeowner's statement of coverage. This warranty is not valid outside of the United States and Canada.

Proof of registration and copy of sales receipt must be on file at the time of claim. Visit our website at www.saproducts.com to register your vault.

Three year warranty only applies to the original owner of the vault.

SA Consumer Products shall only be responsible and liable when the vault is used in compliance with the directions specified in your new SA Consumer Products owner's manual.

SA Consumer Products requires that specific guidelines be followed for repair. The vault will be repaired in-home if possible (to include parts and labor); however, if factory replacement is necessary (at SA Consumer Products' sole discretion), the replacement will be shipped freight prepaid, curbside delivery.

This warranty is inclusive and is in lieu of any and all other warranties, express or implied. Specifically excluded are the warranties of merchantability and fitness for a particular purpose. This warranty is limited to the vault itself and/or its value and does not include consequential damages of any kind including, but not limited to, the contents in and of the vault.