



Anywhere, Anytime



## SAFETY INFORMATION

- Do not try and lift the RTT on your own; make sure to have at least 2 people, using proper lifting techniques.
- Ensure that the RTT is installed correctly and that all connections, straps and surfaces are checked regularly for degradation and loosening.
- Ensure that the roof rack or roof bars can support the full weight of the RTT (70kg) while in motion or supporting two adults.
- Ensure the RTT's weight is centred over the middle of the vehicle and its sides are not over hanging the vehicle.
- The RTT will increase your vehicles overall height, be wary of this when entering undercover areas.
- Take care when operating the telescopic-ladder, ensuring its locked in place and the sliders will not pinch you.

## COMPONENTS

### Included in the kit:

1. Roof Top Tent
2. Telescopic Ladder
3. 8x Flat Brackets
4. 8x Bolts & Nuts
5. 2x Spanner





# INSTALLATION INSTRUCTIONS

At least 2-3 people are needed to install our RTT.

**Do not try and lift and install our tent on your own.**



1. Lift the RTT onto your vehicle's roof rack. Position so that the weight is centred evenly over the roof.

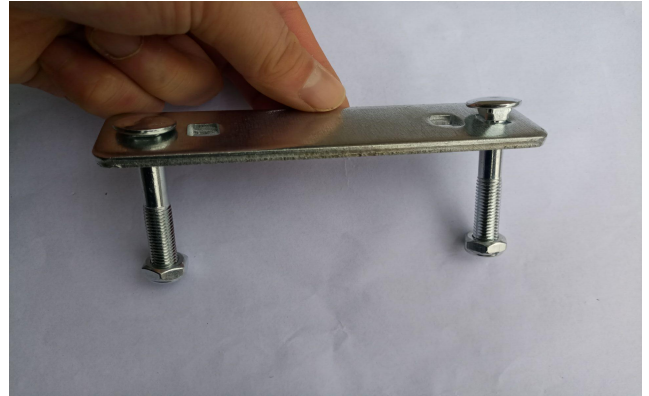

2. Assemble 4 of the flat brackets with 2 bolts each.



3. With the flat brackets assembled, lift the side of the RTT and slide 2 flat brackets with bolts along each mounting rail. Slide the flat brackets with bolts along the mounting rails



4. Connect the 4 remaining flat brackets with 2 nuts each. Tighten all the nuts, making sure the RTT is firmly mounted and will not move. The flat brackets should have a slight bend around the cross bar .

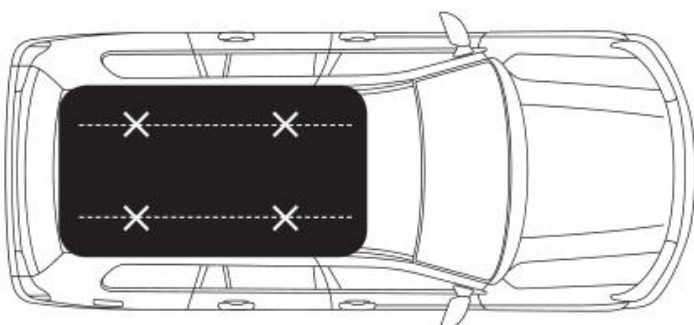

5. The RTT should have 4 spaced, strong points of contact on the roof rack.

Take the vehicle for a low-speed, short drive. Afterwards, check all the bolts are secure. Tighten if required .