



Anywhere, Anytime



SAFETY INFORMATION

- Do not try and lift the RTT on your own; make sure to have at least 2 people, using proper lifting techniques.
- Ensure that the RTT is installed correctly and that all connections, straps and surfaces are checked regularly for degradation and loosening.
- Ensure that the roof rack or roof bars can support the full weight of the RTT (70kg) while in motion or supporting two adults.
- Ensure the RTT's weight is centred over the middle of the vehicle and its sides are not over hanging the vehicle.
- The RTT will increase your vehicles overall height, be wary of this when entering undercover areas.
- Take care when operating the telescopic-ladder, ensuring its locked in place and the sliders will not pinch you.

COMPONENTS

Included in the kit:

1. Roof Top Tent
2. Telescopic Ladder
3. 8x Flat Brackets
4. 8x Bolts & Nuts
5. 2x Spanner



INSTALLATION INSTRUCTIONS

At least 2-3 people are needed to install our RTT.

Do not try and lift and install our tent on your own.



1. Lift the RTT onto your vehicle's roof rack. Position so that the weight is centred evenly over the roof.

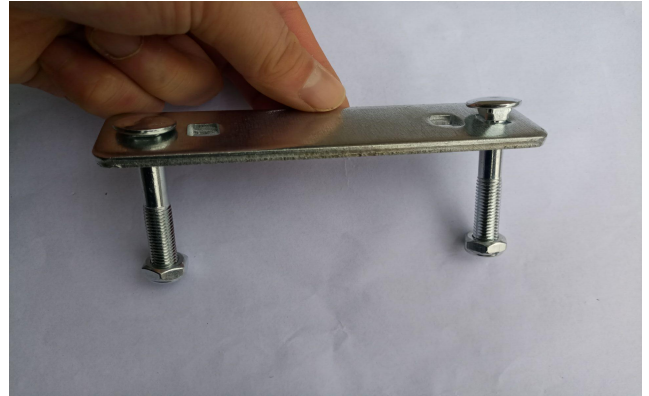

2. Assemble 4 of the flat brackets with 2 bolts each.



3. With the flat brackets assembled, lift the side of the RTT and slide 2 flat brackets with bolts along each mounting rail. Slide the flat brackets with bolts along the mounting rails



4. Connect the 4 remaining flat brackets with 2 nuts each. Tighten all the nuts, making sure the RTT is firmly mounted and will not move. The flat brackets should have a slight bend around the cross bar .

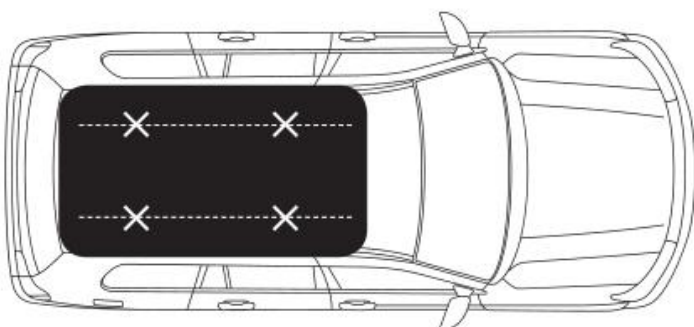

5. The RTT should have 4 spaced, strong points of contact on the roof rack.

Take the vehicle for a low-speed, short drive. Afterwards, check all the bolts are secure. Tighten if required .