

DR[®] RAPIDFIRE™ LOG SPLITTER

SAFETY & OPERATING INSTRUCTIONS



Models:
PRO K28
PRO XLK34

Serial No. _____

Order No. _____

DR Power Equipment
Toll-free phone: 1-800-DR-OWNER (376-9637)
Website: www.DRpower.com

WARNING

Read and understand this manual and all instructions before operating the DR RAPIDFIRE LOG SPLITTER.

Table of Contents

Chapter 1: General Safety Rules..... 4

Chapter 2: Setting Up The DR RAPIDFIRE LOG SPLITTER 8

Chapter 3: Operating The DR RAPIDFIRE LOG SPLITTER..... 12

Chapter 4: Maintaining The DR RAPIDFIRE LOG SPLITTER 15

Chapter 5: Troubleshooting 22

Chapter 6: Parts Lists and Schematic Diagrams 24

Conventions used in this manual

! WARNING

This indicates a hazardous situation, which, if not avoided, **could** result in death or serious injury.

! CAUTION

This indicates a hazardous situation, which, if not avoided, **could** result in minor or moderate injury.

NOTICE

This information is important in the proper use of your machine. Failure to follow this instruction could result in damage to your machine or property.

Serial Number and Order Number

A Serial Number is used to identify your machine and is located on the Serial Number Label on your machine (**Figure 1**). An Order Number is used to check and maintain your order history and is located on the upper left portion of your packing slip. For your convenience and ready reference, enter the Serial Number and Order Number in the space provided on the front cover of this manual.

Additional Information and Potential Changes

DR Power Equipment reserves the right to discontinue, change, and improve its products at any time without notice or obligation to the purchaser. The descriptions and specifications contained in this manual were in effect at printing. Equipment described within this manual may be optional. Some illustrations may not be applicable to your machine.

California Proposition 65

! WARNING
CANCER AND REPRODUCTIVE HARM - www.P65Warnings.ca.gov.

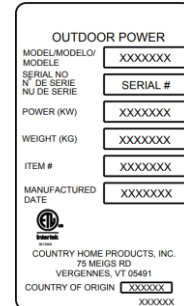

Figure 1

! WARNING

Read this Safety & Operating Instructions manual before you use the DR RAPIDFIRE LOG SPLITTER. Become familiar with the operation and service recommendations to ensure the best performance from your machine. If you have any questions or need assistance, please contact us at www.DRpower.com or call toll-free 1-800-DR-OWNER (376-9637) and one of our Technical Support Representatives will be happy to help you.

Labels

Your DR RAPIDFIRE LOG SPLITTER carries prominent labels as reminders for its proper and safe use. Shown below are copies of all the Safety and Information labels that appear on the equipment. Take a moment to study them and make a note of their location on your LOG SPLITTER as you set up and before you operate the unit. Replace damaged or missing safety and information labels immediately.

#321281

#333611



#188871



#250441



#137581

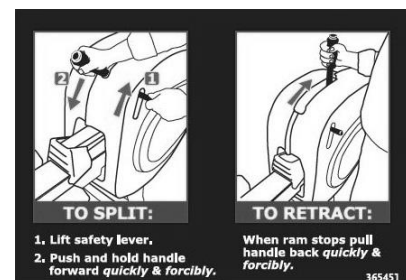

#365451

Protecting Yourself and Those Around You

WARNING

This is a high-powered machine, with moving parts operating with high energy. You must operate the machine safely. Unsafe operation can create a number of hazards for you, as well as anyone else in the nearby area. Always take the following precautions when using this machine:

- Keep in mind that the operator or user is responsible for accidents or hazards occurring to other people, their property, and themselves.
 - Always wear protective goggles or safety glasses with side shields while using the Log Splitter to protect your eyes from possible thrown debris.
 - Avoid wearing loose clothing or jewelry, which can catch on moving parts.
 - We recommend wearing gloves while using the Log Splitter. Be sure your gloves fit properly and do not have loose cuffs or drawstrings.
 - Wear shoes with non-slip treads when using your Log Splitter. If you have safety shoes, we recommend wearing them. Do not use the machine while barefoot or wearing open toed sandals.
 - Wear long pants while operating the Log Splitter.
 - Use ear protectors or ear plugs rated for at least 20 dba to protect your hearing.
 - Keep bystanders at least 50 feet away from your work area at all times. Stop the engine when another person or pet approaches.
-

Safety for Children and Pets

WARNING

Tragic accidents can occur if the operator is not alert to the presence of children and pets. Children are often attracted to the machine and the splitting activity. *Never* assume that children will remain where you last saw them. Always follow these precautions:

- Keep children and pets at least 50 feet from the working area and ensure they are under the watchful care of a responsible adult.
 - Be alert and turn the machine off if children or pets enter the work area.
 - Never allow children to operate the Log Splitter.
-

Towing

WARNING

- ALWAYS check before towing to make certain your Splitter is correctly and securely attached to the towing vehicle. Be sure that the ball hitch you are using is the proper size for the hitch coupler on the machine. Be sure the safety chains are properly hooked to the vehicle leaving enough slack for turning.
 - ALWAYS secure the rack to the beam before towing.
 - ALWAYS use accessory lights and devices when transporting on a road or highway to warn operators of other vehicles. Check your local government regulations for DOT information.
 - ALWAYS allow for added length of the Splitter when turning, parking, crossing intersections, and in all driving situations.
 - ALWAYS be careful when backing up. You could jackknife your Splitter if care is not taken.
 - NEVER exceed 45 mph. when towing your Splitter. Obey all state and local regulations when towing on state and local roads and highways. Adjust your speed for terrain and conditions, as needed. Be extra cautious when towing over rough terrain, especially over a railroad crossing.
 - NEVER allow anyone to sit or ride on your Splitter.
 - NEVER carry any cargo on your Splitter.
 - Do travel slowly over rough terrain, on hillsides, and around curves to prevent tipping.
 - Do not tow the Splitter near the edge of a ditch or excavation.
-

Safety with Gasoline - Powered Machines

! WARNING

Gasoline is a highly flammable liquid. Gasoline also gives off flammable vapor that can be easily ignited and cause a fire or explosion. Never overlook the hazards of gasoline. Always follow these precautions:

- Never run the engine in an enclosed area or without proper ventilation as the exhaust from the engine contains carbon monoxide, which is an odorless, tasteless, and deadly poisonous gas.
 - Store all fuel and oil in containers specifically designed and approved for this purpose and keep away from heat and open flame, and out of the reach of children.
 - Replace rubber fuel lines and grommets when worn or damaged and after 5 years of use.
 - Fill the gasoline tank outdoors with the engine off and allow the engine to cool completely. Don't handle gasoline if you or anyone nearby is smoking, or if you're near anything that could cause it to ignite or explode. Reinstall the fuel tank cap and fuel container cap securely.
 - If you spill gasoline, do not attempt to start the engine. Move the machine away from the area of the spill and avoid creating any source of ignition until the gas vapors have dissipated. Wipe up any spilled fuel to prevent a fire hazard and properly dispose of the waste.
 - Allow the engine to cool completely before storing in any enclosure. Never store a machine that has gas in the tank, or a fuel container, near an open flame or spark such as a water heater, space heater, clothes dryer or furnace.
 - Never make adjustments or repairs with the engine running. Shut down the engine, disconnect the spark plug wire, keeping it away from the spark plug to prevent accidental starting, wait 5 minutes before making adjustments or repairs.
 - Never tamper with the engine's governor setting. The governor controls the maximum safe operation speed and protects the engine. Over-speeding the engine is dangerous and will cause damage to the engine and to the other moving parts of the machine. If required, see your authorized dealer for engine governor adjustments.
 - Keep combustible substances away from the engine when it is hot.
 - Never cover the machine while the muffler is still hot.
 - Do not operate the engine with the air cleaner or the carburetor air intake cover removed. Removal of such parts could create a fire hazard. Do not use flammable solutions to clean the air filter.
 - The muffler and engine become very hot and can cause a severe burn; do not touch.
-

General Safety

! WARNING

Operating this Log Splitter safely is necessary to prevent or minimize the risk of death or serious injury. Unsafe operation can create a number of hazards for you. Always take the following precautions when operating this Log Splitter:

- Your Log Splitter is a powerful tool, not a plaything. Exercise extreme caution at all times. The machine is designed to split logs. Do not use it for any other purpose.
 - Know how to stop the Log Splitter quickly; see "stopping the engine" in chapter 3.
 - Never operate your unit on a slippery, wet, muddy, or icy surface. Exercise caution to avoid slipping or falling.
 - See manufacturer's instructions for proper operation and installation of accessories. Only use accessories approved by DR Power Equipment.
 - Never use the machine without ensuring that all guards and shields are in place.
 - Never, under any conditions, remove, bend, cut, fit, weld, or otherwise alter standard parts on the Log Splitter. This includes all shields and guards. Modifications to your machine could cause personal injuries and property damage and will void your warranty.
 - Allow only one person to operate the Log Splitter at any time.
-

General Safety (continued)

WARNING

- If the machine should start making an unusual noise or vibration, shut down the engine, disconnect the spark plug wire, keeping it away from the spark plug to prevent accidental starting, wait 5 minutes for machine to cool down, then inspect for damage. Vibration is generally a warning of trouble. Check for damaged parts and clean, repair and replace as necessary.
 - Never tamper with safety devices. Check their proper operation regularly.
 - Before performing any maintenance or inspection procedure on the Log Splitter shut down the engine, disconnect the spark plug wire keeping it away from the spark plug to prevent accidental starting, wait 5 minutes for machine to cool down.
 - Never allow people who are unfamiliar with these instructions to use the Log Splitter. Allow only responsible individuals who are familiar with these rules of safe operation to use your machine.
 - Never overload or attempt to split logs beyond the recommendations listed in this manual. Personal injury or damage to the machine could result.
 - While using the Log Splitter, don't hurry or take things for granted. When in doubt about the equipment or your surroundings, stop the machine and take the time to look things over.
 - Never operate the machine when under the influence of alcohol, drugs, or medication.
 - Use the machine only in daylight.
 - Stay alert for hidden hazards or traffic.
 - Keep all nuts and bolts tight and keep the equipment in good operating condition.
-

A Note to All Users

Under California law, and the laws of some other states, you are not permitted to operate an internal combustion engine using hydrocarbon fuels without an engine spark arrester. This also applies to operation on US Forest Lands. All DR RAPIDFIRE LOG SPLITTERS shipped to California, New Mexico and Washington State are provided with spark arresters. Failure of the owner or operator to maintain this equipment in compliance with state regulations is a misdemeanor under California law and may be in violation of other state and/or federal regulations. Contact your State Park Association or the appropriate state organization for specific information in your area.

No list of warnings and cautions can be all-inclusive. If situations occur that are not covered by this manual, the operator must apply common sense and operate this DR RAPIDFIRE LOG SPLITTER in a safe manner. Contact us at www.DRpower.com or call 1-800-DR-OWNER (376-9637) for assistance.

Chapter 2: Setting Up The DR RAPIDFIRE LOG SPLITTER

It may be helpful to familiarize yourself with the controls and features of your DR RAPIDFIRE LOG SPLITTER as shown in Figure 2 before beginning these procedures. If you have any questions at all, please feel free to contact us at www.DRpower.com.

DR RAPIDFIRE LOG SPLITTER Controls and Features

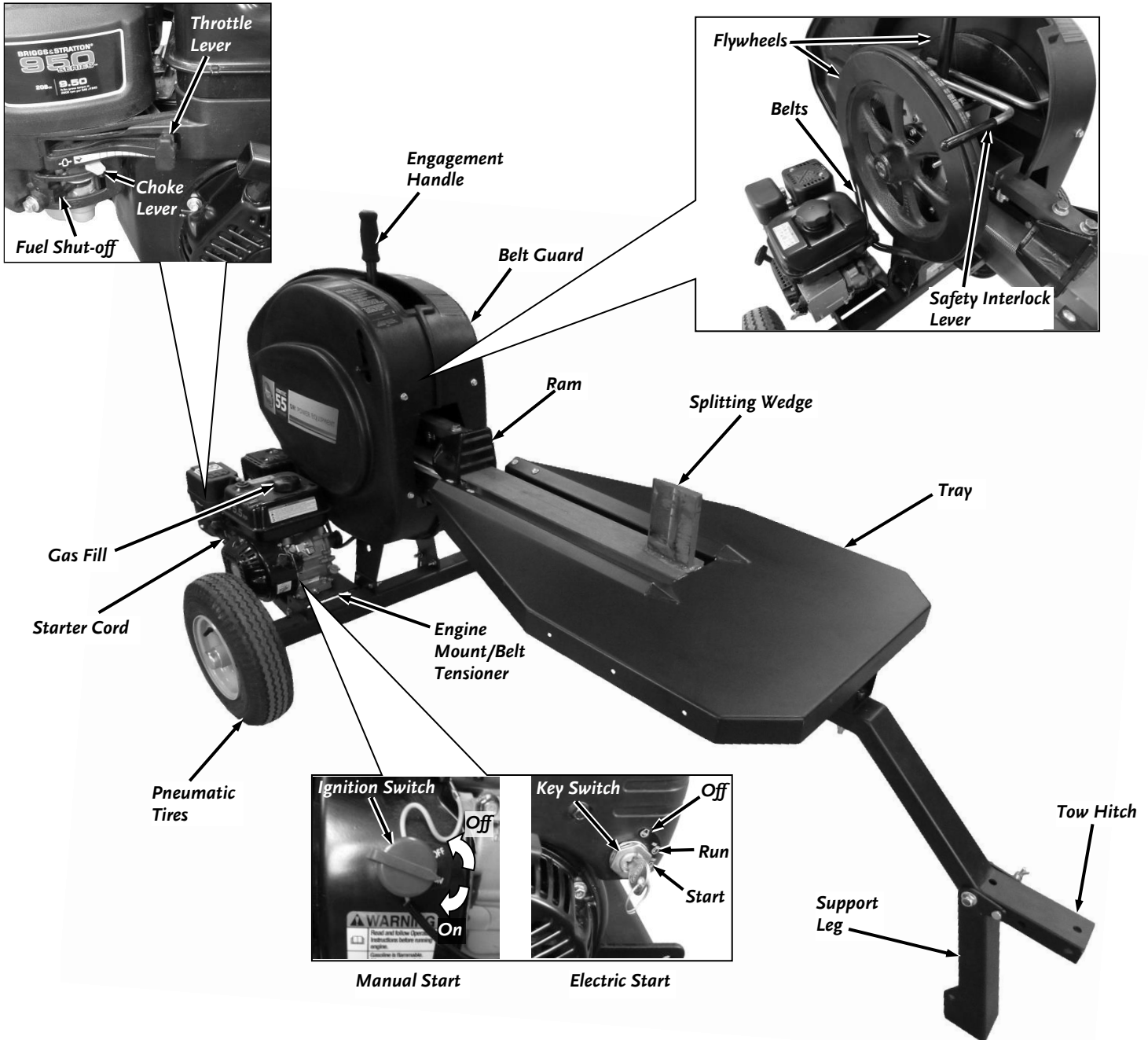

Figure 2

Specifications

| | RapidFire Pro K28 | RapidFire Pro XLK34 (manual start) | RapidFire Pro XLK34 (elec. start) |
|----------------------------|---|---|---|
| Engine | B&S, 7.50 CR (see engine manual for specifications) | B&S, 9.50 CR (see engine manual for specifications) | B&S, 9.50 XR (see engine manual for specifications) |
| Wedge Height | 6-1/4" | 6-1/4" | 6-1/4" |
| Log Capacity | Length 24 inches, Diameter 30 inches* | Length 24 inches, Diameter 30 inches* | Length 24 inches, Diameter 30 inches* |
| Cycle Time | 3 seconds (approx.) | 3 seconds (approx.) | 3 seconds (approx.) |
| Tires | 16" | 16" | 16" |
| Beam Height | 26" | 26" | 26" |
| Overall Height | 48.3" | 48.3" | 48.3" |
| Overall Length w/ Tray | 100.9" | 100.9" | 100.9" |
| Overall Length w/out Tray | 83.5" | 83.5" | 83.5" |
| Width | 46.8" | 46.8" | 46.8" |
| Splitter Weight w/ Tray | 395 lbs. (179kg) | 435 lbs. (197kg) | 440 lbs. (200kg) |
| Splitter Weight w/out Tray | 363 lbs. (165kg) | 403 lbs. (183kg) | 408 lbs. (185kg) |
| Flywheel Weight | 55 lbs. (34kg) | 74 lbs. (34kg) | 74 lbs. (25kg) |
| Flywheel Diameter | 18-1/4" | 18-1/4" | 18-1/4" |
| Flywheel Max RPM | 400 RPM | 400 RPM | 400 RPM |

*The diameter listed is indicative of the maximum suggested size - a small log can be difficult to split when it contains knots or a particularly tough fiber. On the other hand, it may not be difficult to split logs with regular fibers even if its diameter exceeds the maximum indicated above.

Assembling the DR RAPIDFIRE LOG SPLITTER

Tools and Supplies needed:

- Utility Knife
- Wire Cutters
- Gloves
- Two 9/16" Wrenches

Installing the Tray Kit

Parts Supplied in Tray Kit (Figure 3):

| Item # | Part # | Description | Qty |
|--------|--------|--------------------------------------|-----|
| 1 | 313631 | Table, Log (not shown) | 1 |
| 2 | 321041 | Bolt, Carriage, 3/8-16 X 1", GR5, ZP | 4 |
| 3 | 333331 | Nut, Nylon Lock, Flanged, 3/8-16 | 4 |
| 4 | 150431 | Bolt, HHCS, 3/8-16 X 1-1/4", GR5 | 4 |
| 5 | 112411 | Washer, Flat, 5/16", USS, ZP | 4 |
| 6 | 180811 | Washer, Lock, 3/8" | 4 |

Compare the contents of the Tray Kit with the "Parts Supplied" list above. If you have any questions, please contact us at www.DRpower.com or call 1-800-DR-OWNER (376-9637) for assistance.

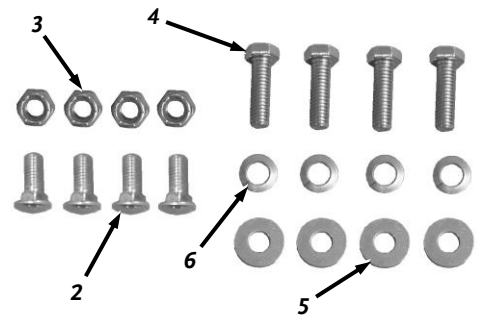

Figure 3

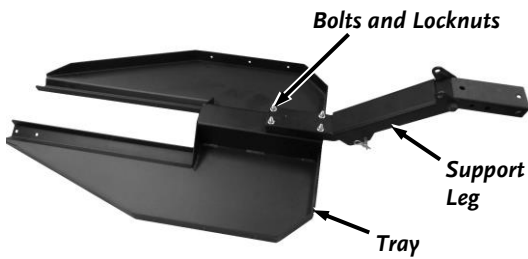

Figure 4

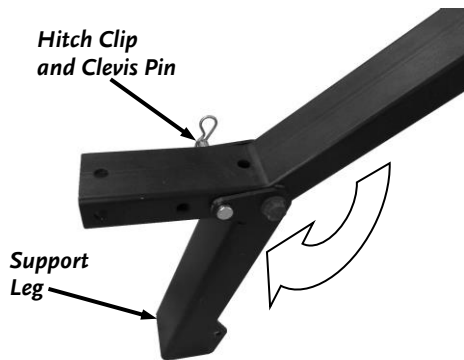

Figure 5

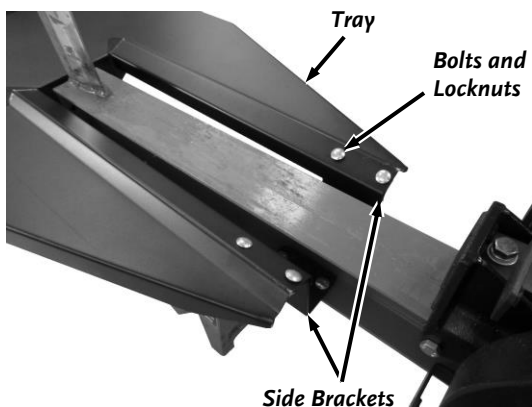

Figure 6

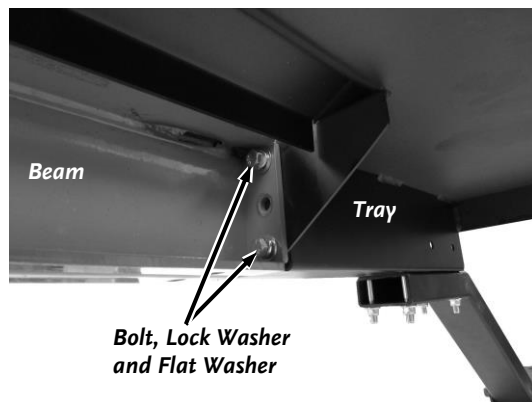

Figure 7

1. Support the end of the Beam with a Jack Stand or equivalent to position the Beam parallel with the ground.
2. Install the Tow Bar to the Tray with four 3/8-16 X 2.5 Bolts and Lock Nuts (from product package) using two 9/16" Wrenches (**Figure 4**).
3. Pull the Hitch Clip and Clevis Pin from the Leg and fold it to the down position. Align the holes and secure the Leg with the Clevis Pin and Hitch Clip (**Figure 5**).
4. For easier alignment in the following step, slightly loosen the Side Bracket Hardware using a 9/16" Wrench (**Figure 6**).
5. Position the Tray onto the Side Brackets and install the four Carriage Bolts and Locknuts (from the tray kit) by hand.
6. Install the four Bolts, Lock Washers and Flat Washers (from the tray kit) to secure the Tray to the end of the Beam using a 9/16" Wrench (**Figure 7**).
7. Tighten all remaining Tray hardware using a 9/16" Wrench.

Adding Oil and Gasoline

| | |
|-------------------|---|
| Engine Oil | See Engine Manual for specific Engine capacities and specifications |
| Fuel | Unleaded gasoline |

NOTE: Use only the recommended high detergent engine oil. Other types of oil could cause problems operating your machine. Please refer to your Engine Owner's Manual for detailed oil information.

Supplies Needed:

- Clean Rag
- Engine Oil

NOTICE

The Engine must be level to get an accurate reading when adjusting the amount of oil. If the machine is not level, the oil level reading will not be accurate and may cause engine damage.

1. Position the machine so the Engine is level. Remove the Oil Fill/Dipstick (**Figure 8**) and clean the end of it with a rag.

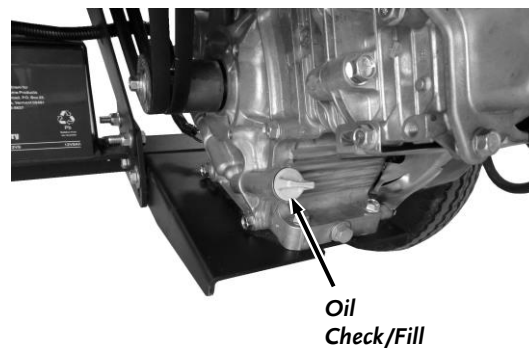

Figure 8

2. **Machines are shipped with no oil.** Initially add 16 oz. of the oil recommended by the Engine Manufacturer. Wait one minute for the oil to settle.
3. Replace the Dipstick, but **DO NOT** screw it in to ensure an accurate reading and then remove it to check the oil level (clean the Dipstick with the clean rag after checking).
4. Continue adding a few ounces of oil at a time, rechecking the Dipstick until the oil reaches the fill mark. Be careful not to overfill.
5. Replace the Dipstick and screw all the way down when full.
6. Remove the Gas Fill Cap and fill the Gas Tank with fresh, unleaded gas (with a minimum of 85 Octane) to approximately 1" to 1-1/2" below the top of the fill neck to allow for fuel expansion (**Figure 9**). Be careful not to overfill. Install the Gas Fill Cap before starting the engine. See your Engine Owner's Manual for more detailed information.

NOTE: To refill the gas tank, turn the engine OFF and let the engine cool at least five minutes before removing the gas fill cap.

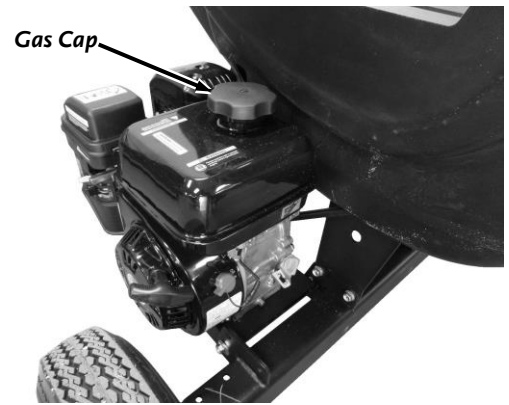

Figure 9

NOTICE

We highly recommend the use of fuel treatments in your fuel to prevent Carburetor fouling.

Check the Tire Pressure

Tools Needed:

- Tire Pressure Gauge
- Air Compressor

1. Remove the Valve Stem Protective Cap (**Figure 10**) and check the tire pressure with a Tire Pressure Gauge.
2. Check what the manufacturers recommended pressure is that is stamped on the side of the Tire.
3. If the pressure is too low, add air through the Valve Stem with an air hose.
4. Replace the Valve Stem Protective Cap when finished.



Figure 10

⚠ WARNING

Do not over inflate the tires. Inflate to the manufacturers recommended pressure found on the tires.

Connect the Battery (electric start models)

1. Connect the Black Negative Terminal onto the negative Battery Lug (**Figure 11**).

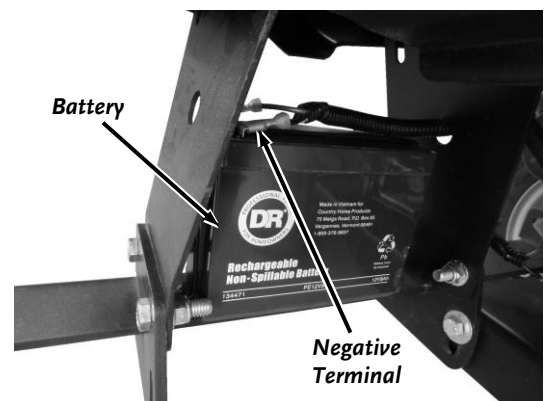

Figure 11

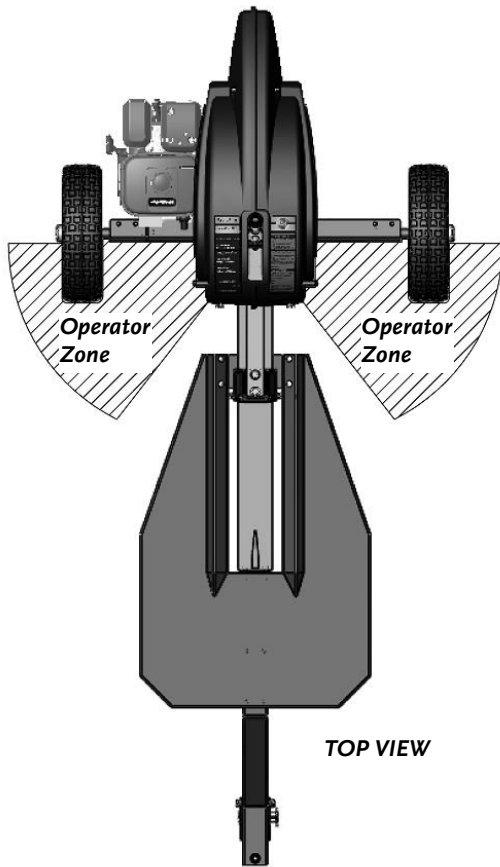

Figure 12

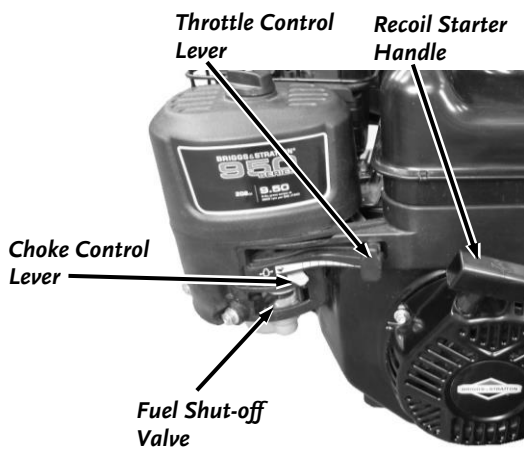

Figure 13

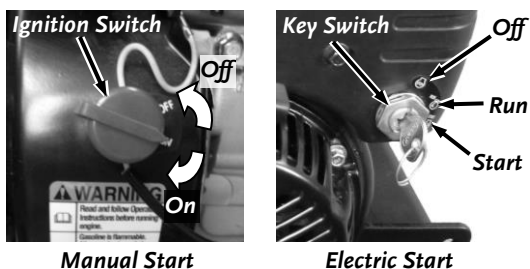

Figure 14

It may be helpful to better familiarize yourself with the features of your Log Splitter by reviewing **Figure 2** in Chapter 2 before beginning the steps outlined in this chapter.

⚠ WARNING

- Read and understand all instructions, safety precautions, and/or warnings listed in “Chapter 1 General Safety Rules” before operating this DR RAPIDFIRE LOG SPLITTER. If any doubt or question arises about the correct or safe method of performing anything found in this manual, please contact our Customer Service Representatives at our toll-free number: 1-800-DR-OWNER (376-9637).
- When operating the Log Splitter, make sure you are standing in the safe operating area (OPERATOR ZONE) as shown in **Figure 12**. You must stay in the safe operating area at all times when the ram is in motion (whether extending or retracting). Never place any part of your body into a position that causes an unsafe operating condition.

Starting the Engine

Note: See the Engine Manual for more detailed and specific information on operating the Engine.

1. Position your Log Splitter on flat, dry ground and chock the Wheels to prevent the Splitter from moving during use.
2. Make sure the fuel shut-off valve is in the “ON” position (**Figure 13**).
3. Move the choke control lever to the CHOKE position to the left (should only be needed if the engine is cold).
4. Move the throttle control lever to the FAST “Rabbit” position.
5. Manual Start: Turn the Ignition Switch to the “On” position (**Figure 14**). Grasp the recoil starter handle and slowly pull until you feel resistance (**Figure 13**). Let the cord retract a little bit then pull the cord rapidly to start the engine. One or two pulls usually starts the engine.
6. Electric Start: Turn and hold the Key in the “Start” position until Engine starts then let the Key return to run position (**Figure 14**).
7. Move the choke control lever (if used for cold engine) slowly back to the OPEN position (to the right) when the engine is running well (**Figure 13**).

Note: If the Log Splitter has not been running (cold engine), warm up the engine by running the engine at half throttle for 3 to 4 minutes, then advance the engine throttle control to maximum speed.

Stopping the Engine

1. Move the Throttle Lever to Idle “Turtle” position (**Figure 13**).
2. Manual Start: Turn the Ignition Switch to the “Off” position (**Figure 14**).
3. Electric Start: Turn the Key to the “Off” position.

Splitting

Note: All logs should be no longer than 24". Use the following photos for the correct and incorrect methods of splitting logs. Never split a log using an incorrect or unsafe method.

WARNING

- Do not place your hands on the ends of the log when loading the Log Splitter. This is a very UNSAFE method and could result in injury to your hands (**Figure 15**).
- Do not reach or step across the beam while the Log Splitter is running. This is a very UNSAFE method which could cause personal injury or even death.

CAUTION

- Never attempt to split wood across the grain. The Log Splitter was not designed for cross-grain splitting. Doing so could damage the Log Splitter and may cause personal injury (**Figure 16**).
- Make sure both ends of the log you are splitting are cut as square as possible. This will prevent the log from sliding out of position while under pressure (**Figure 17**).

NOTICE

THE RAPIDFIRE LOG SPLITTER OPERATES DIFFERENTLY THAN A HYDRAULIC SPLITTER. NOT OPERATING THE MACHINE PROPERLY WILL RESULT IN DAMAGE TO THE MACHINE. ALWAYS FOLLOW THESE NOTICES:

- Do not be timid. A rapid movement of the Engagement Handle is necessary for the Rack and Pinion to engage and disengage fully without damage.
- The Engagement Handle should never be stopped in any location between the fully forward or fully backward positions.
- Do not hold the Handle in the forward position when the Ram stops moving forward. Always pull the Engagement Handle RAPIDLY to the back (Auto-Retract) position as soon as the Log is split or when the Ram is at the end of the stroke or when the Ram stops moving forward due to a tough log.

1. Place the log on the Log Splitter. Grasp the log on the sides near the middle of the block (**Figure 18**). Center the log, side-to-side, on the rail of the Log Splitter, making sure that one end is against the Splitting Wedge.

CAUTION

The engagement Handle must be held fully forward against the hard stop when splitting. Failure to do so may result in kickback of the Handle.



Figure 15



Figure 16



Figure 17

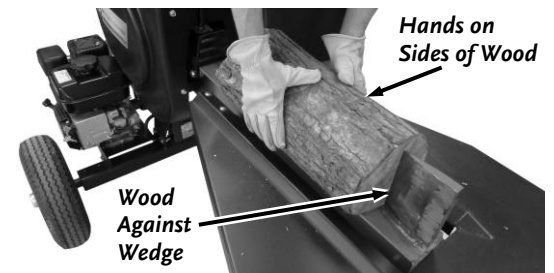

Figure 18

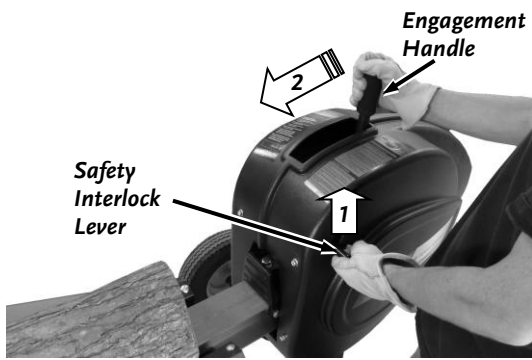

Figure 19

2. With one hand, lift and hold the Safety Interlock Lever up, then **RAPIDLY** press the Engagement Handle fully forward until it contacts the hard stop and hold firmly until the Log is split (**Figure 19**).
3. **IMMEDIATELY AFTER** the log is split, pull and hold the Engagement Handle to the Auto-Retract position to allow the Ram to return. If the Ram stops before the end of the stroke while splitting a tough log, quickly pull the Engagement Handle back to the Auto-Retract position.

Splitting Tough Logs

If the Ram stops before the end of the stroke while splitting a tough Log, quickly pull the Engagement Handle back to the Auto-Retract position. Let the Ram return and allow the Flywheels to gain momentum for another full power split.

Chapter 4: Maintaining the DR RAPIDFIRE LOG SPLITTER

Regular maintenance is the way to ensure the best performance and long life of your machine. Please refer to this manual and the engine manufacturer's owner's manual for maintenance procedures. Service intervals listed in the checklist below supersede those listed in the engine manufacturer's owner's manual.

⚠ WARNING

Before performing any maintenance procedure or inspection, stop the engine, wait five minutes to allow all parts to cool. Disconnect the spark plug wire, keeping it away from the spark plug. Disconnect the Battery Terminals (Electric start only).

Regular Maintenance Checklist

| PROCEDURE | BEFORE EACH USE | EVERY 10 HOURS | EVERY 25 HOURS | EVERY 100 HOURS |
|-----------------------------------|------------------------------|----------------|----------------|-----------------|
| Check Engine Oil Level | ▲ | | | |
| Check General Equipment Condition | ▲ | | | |
| Perform Rail Maintenance | ▲ | | | |
| Check Belts | ▲ | | | |
| Grease Engagement Handle | | ▲ | | |
| Check Tire Pressure | | | ▲ | |
| Clean Engine Exterior and Cooling | | | ▲ | |
| Change Engine Oil | 1 st time 5 hours | | ▲ | |
| Replace Air Filter | | | ▲ | |
| Replace Spark Plug | | | | ▲ |

Engine Service

Refer to the engine manufacturer's manual for engine maintenance.

Lubrication

All Bearings of your Splitter are sealed units and should have sufficient lubricant to last the life of your machine with normal use. Perform machine lubrication per the following instructions.

Changing Engine Oil

One of the easiest methods to remove oil from this Engine is to use a siphon style Oil Extractor. If you do not have one you can purchase it from us at www.DRpower.com.

Tools and Supplies needed:

- Clean Approved Container for used Oil
- 10mm Wrench

1. Place an approved Container under the Oil Plug.
2. Remove the Oil Drain Plug with a 10mm Wrench to drain the Oil into the Container (**Figure 20**).
3. Reinstall the Oil Drain Plug.
4. Add oil as described in "Adding Oil and Gasoline" in Chapter 2.

Rail Maintenance

Between each use of the LOG SPLITTER, we recommend applying a rust preventative (Fluid Film or equivalent) to any bare metal areas on the top of the rail (**Figure 21**). This will assure the smoothest return action of the ram.

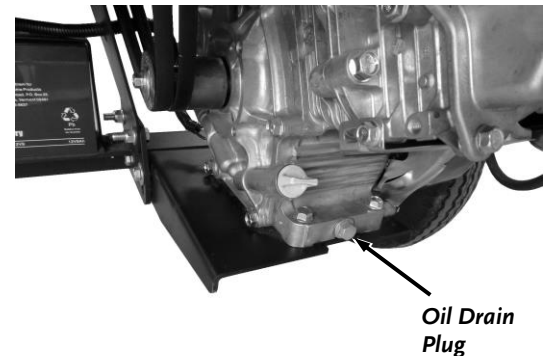

Figure 20

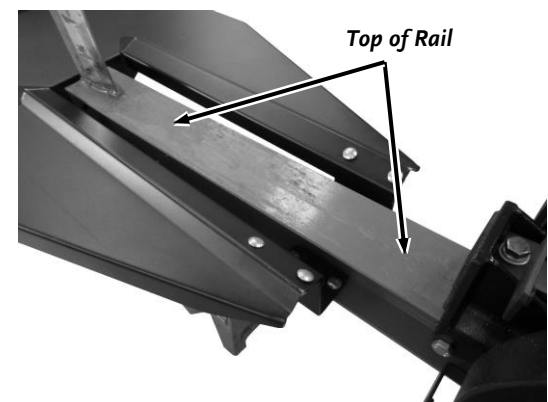

Figure 21



Figure 22

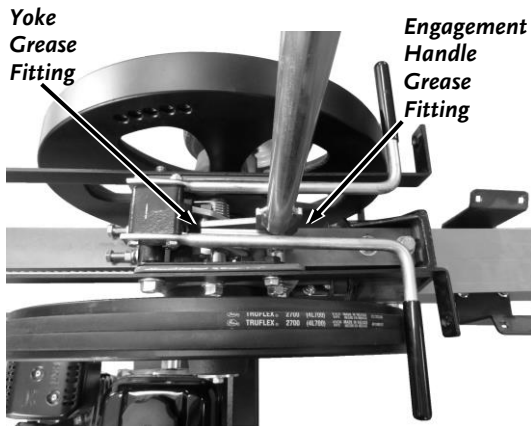

Figure 23

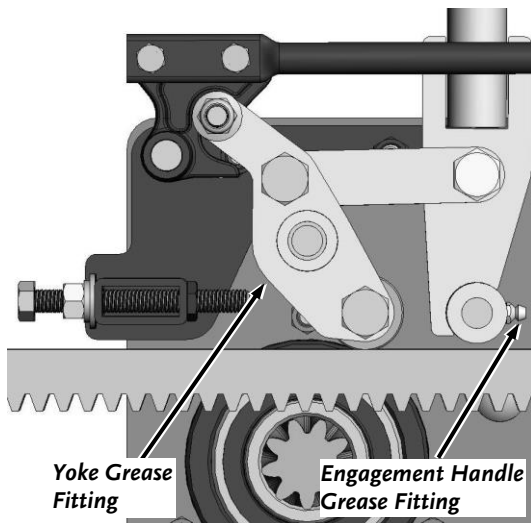

Figure 24

Greasing the Engagement Handle and Yoke

Tools and Supplies needed:

- Two 9/16" Wrenches
- Extended Hose Grease Gun with all Purpose Grease
- Clean Rags

1. Remove the two Flange Bolts and Washers at the front of the right side Guard using a 9/16" Wrench (**Figure 22**).
2. Remove the two locknuts and Washers at the rear of the guard using two 9/16" Wrenches. Remove the right side Guard from the Splitter.
3. Clean the Engagement Handle and Yoke Grease Fittings with a clean Rag (**Figure 23 and 24**).
4. Grease the Engagement Handle Grease Fitting with a few pumps of All Purpose Grease.

Note: If there is a Height Adjustment Bolt in front of the Yoke Grease Fitting preventing access (**Figure 25**), you will need to remove it using a 9/16" Wrench. Not all machines have the Height Adjustment Bolt.

5. Grease the Yoke with a few pumps of All Purpose Grease.
6. Reinstall and adjust the Height Adjust Bolt only enough so the Handle is not touching the Belt (**Figure 26**). Hold the Bolt still while tightening the Jam Nut using two 9/16" Wrenches (**Figure 25**).
7. Ensure that the Spacers are on the Rear Guard Bolts (**Figure 29 on next page**) and reinstall the right side Guard (**Figure 22**).

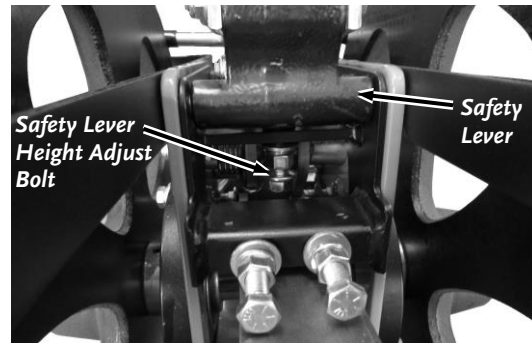

Figure 25



Figure 26

Changing and Adjusting the Belts

Tools and Supplies needed:

- Two 9/16" Wrenches
- DR Belts

1. Remove the two Flange Bolts and Washers at the front of the right side Guard using a 9/16" Wrench (**Figure 27**).
2. Remove the two locknuts and Washers at the rear of the guard using two 9/16" Wrenches. Remove the right side Guard from the Splitter.
3. Loosen the front two Engine Mount Pivot Bolts and Locknuts with two 9/16" Wrenches (**Figure 28**).
4. Loosen the rear two Angle Setting Bolts with Flat Washers using two 9/16" Wrench.
5. Pivot the Mount up slightly and remove the Belts.

Note: The weight of the Engine should be enough to tension the Belts properly but depending on hardware looseness and cleanliness of Engine Mount pivot area, you may need to push down slightly to aid in proper tension. The Belts perform best with a slight amount of slack to allow for some slippage when the Wedge encounters a tough log. Too much tension may stall the engine or slip the belt on the engine pulley.

6. Install the new Belts around the center of the Flywheel and the Engine Pulley and adjust tension as described in the note above (**Figure 29**).
7. Tighten the two Engine Mount Bolts that are at the center of the machine (shown) first and then tighten the outer two Bolts (**Figure 28**).
8. Ensure that the Spacers are on the Rear Guard Bolts (**Figure 29**) and reinstall the right side Guard (**Figure 27**).

Adjusting the Rack Alignment

Tools and Supplies needed:

- 9/16" Wrench
- 7/16" Wrench

1. Remove the two Flange Bolts and Washers at the front of the right side Guard using a 9/16" Wrench (**Figure 27**).
2. Remove the two locknuts and Washers at the rear of the guard using two 9/16" Wrenches. Remove the right side Guard from the Splitter.
3. Pull the Ram out enough to disconnect the Return Springs from the Ram Bearing Hardware (**Figure 30**) and pull the Ram out to the Wedge.
4. Center the Rack to the Frame.



Figure 27

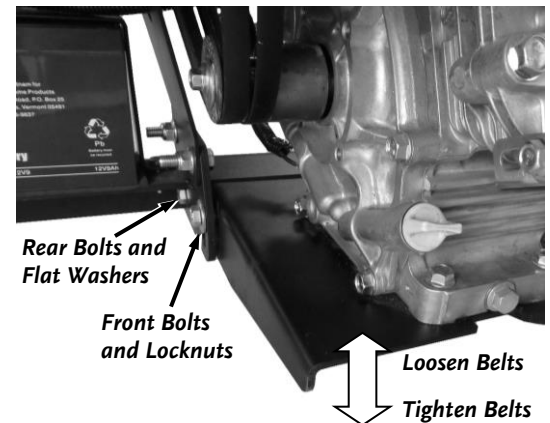

Figure 28

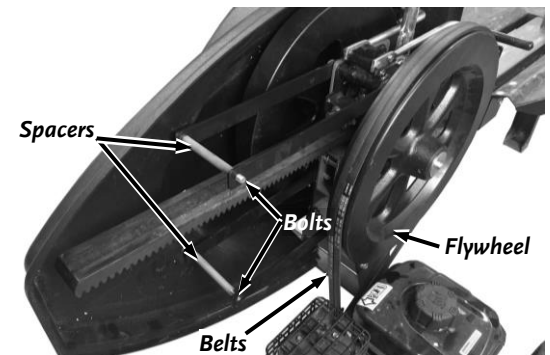

Figure 29

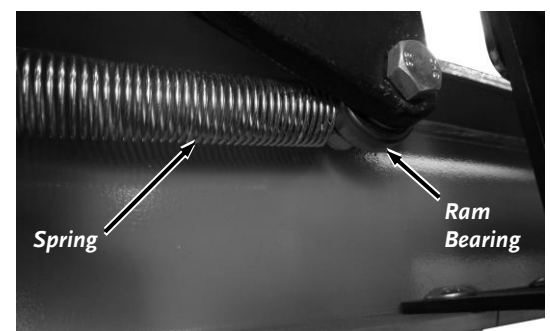

Figure 30

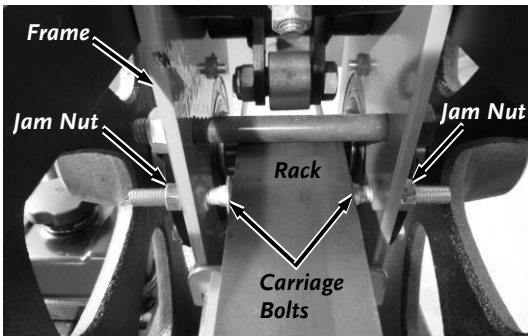

Figure 31



Figure 32

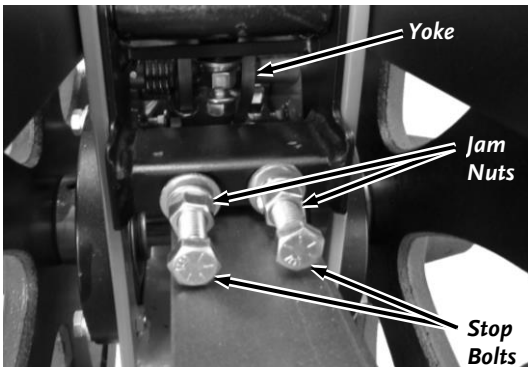

Figure 33

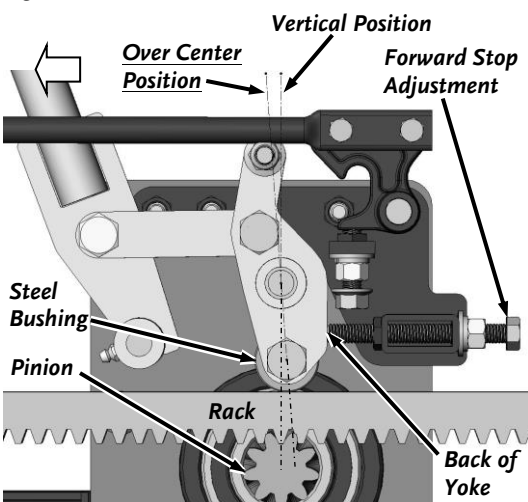

Figure 34

5. Loosen the Jam Nuts with a 9/16" Wrench and turn the Carriage Bolts with a 10mm Wrench until they touch the Rack (**Figure 31**).
6. Turn each Carriage Bolt back away from Rack two turns.
7. Tighten the Locknuts against the Frame to lock the Carriage Bolts into place.
8. Replace the Guard.

Adjusting the Steel Bushing Over Center

Tools needed:

- Two 9/16" Wrenches
- 9/16" Socket and Ratchet

1. Remove the two Flange Bolts and Washers at the front of the right side Guard using a 9/16" Wrench (**Figure 32**).
2. Remove the two locknuts and Washers at the rear of the guard using two 9/16" Wrenches. Remove the right side Guard from the Splitter.
3. Loosen the Stop Bolt Jam Nuts (**Figure 33**).
4. Lift the Safety Interlock Lever and push the Engagement Handle forward to position the Steel Bushing Yoke as close to vertical as you can and hold it there (**Figure 34**).
5. Rotate the Stop Bolts until they touch the Steel Bushing Yoke. Turn the Bolt back out of the Frame counterclockwise 1-1/4 revolutions. Tighten the Jam Nuts with a 9/16" Wrench to lock the Stop Bolts at this position.

NOTICE

Do not adjust more than 1-1/4 revolutions when adjusting off center. Adjustment too far off center will not allow the Rack Teeth to engage fully and will cause damage to the Splitter.

6. Ensure that the Spacers are on the Rear Guard Bolts (**Figure 35**), and reinstall the right side Guard (**Figure 32**).

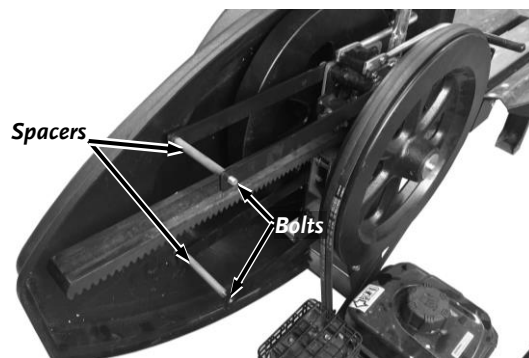

Figure 35

Greasing the Rack

It is important to grease the Rack every 5 hours for proper operation.

Tools and Supplies needed:

- General Purpose Lithium Grease
 - Clean Rags
1. Pull out the Ram and slide both return Spring ends from the Ram Bearing hardware (**Figure 36**).
 2. Pull the Rack out and grease the Teeth (**Figure 37**).
 3. Reinstall the Spring ends when finished greasing.

Replacing the Wheels

Tools and Supplies needed:

- Channel lock Pliers
- Clean Rags
- Adjustable Wrench
- Needle Nose Pliers
- Jack and Jack Stands
- Hammer and Wood Block

⚠ CAUTION

The Splitter must be supported carefully so it does not tip over when jacking or it could cause Splitter damage or personal injury.

1. Jack the Splitter off the ground and secure with Jack Stands.
2. Remove the Dust Cap from the Wheel Assembly with Channel Lock Pliers (**Figure 38**).
3. Straighten the ends of the Cotter Pin with Needle Nose Pliers so the Cotter Pin can be pulled from the hole in the Axle (**Figure 39**).
4. Remove the Castle Nut with the Channel Lock Pliers.
5. Pull the Wheel assembly and Taper Bearing from The Axle (**Figure 40**).
6. Slide a Wheel Assembly onto the Axle Shaft with the Valve Stem facing out. The open side of the Wheel Hub with the loose Taper Bearing will be facing towards you.

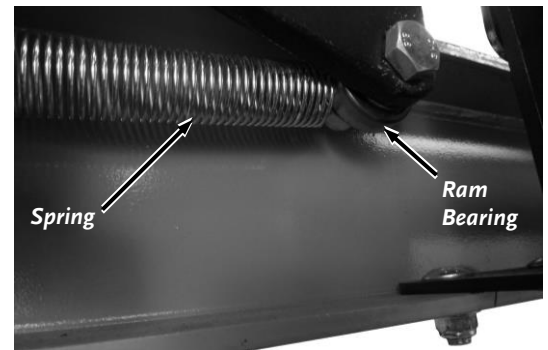

Figure 36

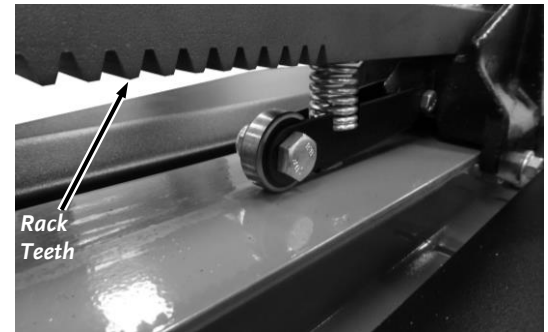

Figure 37



Figure 38

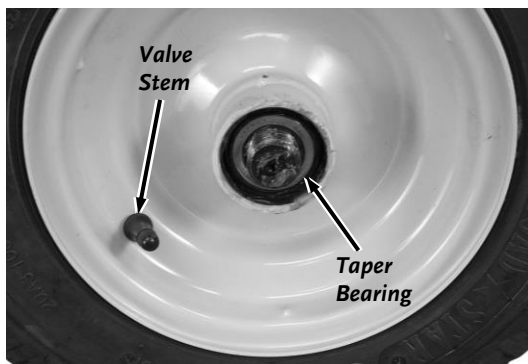

Figure 40

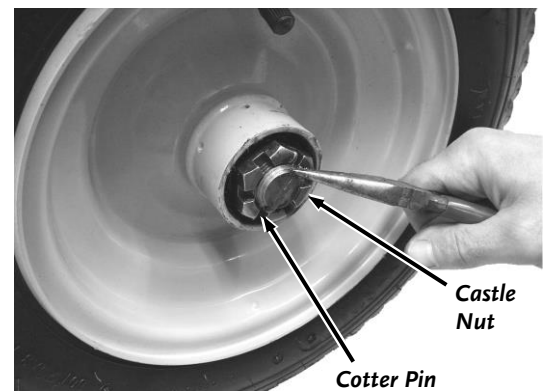

Figure 39

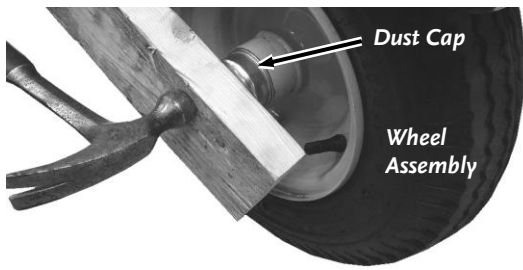

Figure 41

7. Screw the Castle Nut onto the Axle and tighten it with an Adjustable Wrench to seat the Bearings (**Figure 39**).
8. Back the Castle Nut off and then snug it up to the Bearing lightly.
9. Insert a Cotter Pin through the slots of the Castle Nut and into the hole in the Axle.
10. Bend the ends of the Cotter Pin with Needle Nose Pliers to secure it.
11. Place the Dust Cap onto the Wheel Assembly and secure it by placing a piece of wood over it and pounding lightly with a Hammer until it is seated against the lip (**Figure 41**).
12. Jack the back of the Splitter up and remove the Jack Stands.
13. Lower the Splitter to the ground.

Replacing the Battery

Tools Needed:

- Two 7/16" Wrenches



When working with batteries take care not to short the positive terminal with the battery strap

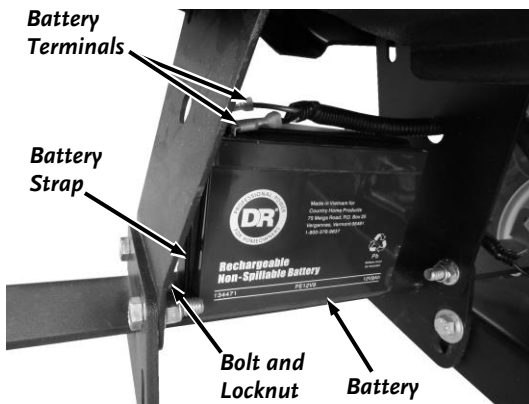

Figure 42

1. Disconnect the Battery Terminals (**Figure 42**).
2. Remove the Bolts and Locknuts that secure the Battery Strap using two 7/16" Wrenches.
3. Remove the Strap and the old Battery.
4. Install the new Battery.
5. Install the Battery Strap and secure with the Bolts and Locknuts using two 7/16" Wrenches.
6. Attach the Battery Terminals. Black Wire to the negative black Terminal and Red Wire to the positive red Terminal.

Battery Care (electric start models)

Proper care can extend the life of a Battery. Follow these recommendations to ensure your Battery's best performance and long life:

- Do not allow the Battery charge to get too low. If the machine is not used, charge the Battery every 4 – 6 weeks. Operate the engine for at least 45 minutes to maintain proper Battery charge.
- Store an unused Battery in a dry environment with temperatures between +40°F (+5°C) and +95°F (+35°C). Make sure the storage temperatures will never be outside of these limits. The lower the storage temperature is within the specified temperature, the better as the battery will discharge more slowly at low temperatures.
- Do not charge an already charged Battery. In theory, you cannot overcharge our Battery with a trickle charger; however, when a Battery is fully charged, and the charger is still on, it generates heat that could be harmful to the Battery. A fully charged Battery will read 12V-13.2V with a voltmeter.
- Do not continue to crank your Engine when the Battery charge is low.

Charging the Battery

Operate the Engine for at least 45 minutes to maintain proper Battery charge. If the Battery loses its charge, you will need to use a trickle charger (like the DR Battery Charger) to recharge it. The Charger should have an output of 12 volts DC at no more than 2 amps.

- At 1 amp the Battery may need to be charged for as long as 48 hours.
- At 2 amps, the Battery may need to be charged for as long as 24 hours.

NOTE: *Using the Recoil Starter and then running the Engine will not recharge a dead or significantly discharged Battery.*

To connect a Battery Charger to your DR RAPIDFIRE LOG SPLITTER, follow the steps listed below.

1. Attach the Black (-) alligator clipped wire from the Charger Adapter to the Negative (-) terminal of the Battery, then attach the Red (+) alligator clipped wire to the Positive (+) Battery terminal.
2. Plug the Charger into a standard wall outlet.
 - Typically, the Battery takes between 6 and 8 hours to fully charge. Do not leave the charger on the battery longer than 24 hours for a 2 amp charger, or 48 hours for a 1 amp charger as you could potentially damage the Battery..
 - You can charge the Battery many times. The Battery lasts longer if you charge it before it is fully drained. Keep it fully charged and at room temperature when not using your DR RAPIDFIRE LOG SPLITTER.
 - If the Battery does not hold its charge for very long under normal conditions or it simply won't hold a charge, then replace it. You can purchase replacement Batteries directly from us. To install your new Battery, follow the directions on the previous page.

NOTICE

When you are finished charging the Battery, disconnect the Charger from the outlet first, then disconnect the Battery Charger Wires from the Battery. If you leave the Battery Charger Wires connected to the Battery, the Battery will discharge itself back into the Charger.

Disposing of the Battery Responsibly

The Battery is a sealed lead-acid Battery. Recycle or dispose of it in an environmentally sound way.

- Do not dispose of a lead-acid Battery in a fire; the Battery may explode or leak.
- Do not dispose of a lead-acid Battery in your regular, household trash. Law in most areas prohibits incinerating, disposing in a landfill, or mixing a sealed lead-acid Battery with household trash.

Recycling a Used Battery

Please dispose of your used Batteries responsibly by recycling them. Call your local Solid Waste Management District or your local waste handler to locate the collection site nearest you. Some collection sites recycle Batteries year-round; others collect them periodically.

You can also visit the Web site of Earth 911 for more information [www.earth911.org]. Enter the search term 'battery' and your zip code in the search function at the top of the page. The site lists recycling centers located near you.

For a fee, you can recycle your Batteries with the International Metals Reclamation Company. Visit them at www.inmetco.com and click Services; or contact them at:

INMETCO, One INMETCO Drive, Ellwood City, PA 16117, (724) 758-2800; fax (724) 758-2845

To learn more about hazardous waste recycling, visit the Web site for Battery Council International [www.batterycouncil.org] or for the Environmental Protection Agency [www.epa.gov].

Chapter 5: Troubleshooting

Most problems are easy to fix. Consult the Troubleshooting Table below for common problems and their solutions. If you continue to experience problems, contact us at www.DRpower.com or call toll-free 1-800-DR-OWNER (376-9637) for support.

WARNING

Before performing any maintenance procedure or inspection, stop the engine, wait five (5) minutes to allow all parts to cool. Disconnect the spark plug wire, keeping it away from the spark plug.

Troubleshooting Table

| SYMPTOM | POSSIBLE CAUSE |
|--|---|
| <p><i>The engine won't start.</i></p> <p><i>(Please refer to the engine owner's manual for engine-specific procedures.)</i></p> | <ul style="list-style-type: none"> ⇒ Is the ignition switch in the "On" position? ⇒ Is the fuel shut-off valve on? ⇒ Are you using fresh, clean gas? If the gas is old, change it. Use a fuel stabilizer if you keep gas longer than 30 days. ⇒ Is the spark plug clean? If the spark plug is dirty or cracked, change it. If it's oily, leave it out, hold a rag over the plug hole and pull the recoil cord several times to blow out any oil in the cylinder, then wipe off the plug and reinsert it. ⇒ If your engine still won't start, contact us at www.DRpower.com for assistance. |
| <p><i>The engine lacks power or is not running smoothly.</i></p> <p><i>(Please refer to the engine owner's manual for engine-specific procedures.)</i></p> | <ul style="list-style-type: none"> ⇒ Check that the Throttle Lever is in the "Run" position and the Choke is off. ⇒ Is the air filter clean? If it's dirty, change it following the procedure in the engine manufacturer's owner's manual. ⇒ Is the spark plug clean? If it's fouled or cracked, change it. If it's oily, leave it out, hold a rag over the plug hole and pull your recoil cord several times to blow out any oil in the cylinder, then wipe off the plug and reinsert it. ⇒ Are you using fresh, clean unleaded gas? If it's old, change it. Use a fuel stabilizer if you keep gas longer than 30 days. ⇒ Does your engine have the right amount of clean oil? If it's dirty, change it following the procedure in the engine manufacturer's owner's manual. ⇒ Check the oil level and adjust as needed. ⇒ If your engine still lacks power, contact us at www.DRpower.com for assistance. |
| <p><i>Engine smokes.</i></p> <p><i>(Please refer to the engine owner's manual for engine-specific procedures.)</i></p> | <ul style="list-style-type: none"> ⇒ The choke may still be on; Move the choke lever to the open position. ⇒ Check the oil level and adjust as needed. ⇒ Check the air filter and clean or replace if needed. ⇒ You may be using the wrong oil—too light for the temperature. Refer to your Engine Owner's Manual for detailed information. ⇒ Clean the cooling fins if they're dirty. ⇒ If the engine still smokes, contact us at www.DRpower.com for assistance. |
| <p><i>Rack catching on tail tube (at end of stroke).</i></p> <p><i>Rack returning very slow or not returning properly.</i></p> | <ul style="list-style-type: none"> ⇒ Check for wood chips or debris between ram bushing plate and beam. Clean beam of built up/caked on debris. ⇒ Check rack lift bearing for alignment or damage. ⇒ Return spring is unhooked or damaged. Reconnect or replace as needed. ⇒ Machine wedge end too low. Must be almost level or wedge end slightly higher. Perform rail maintenance and lubricate the beam- prolonged exposure may rust the beam without lubrication. |

Troubleshooting Table (Continued)

WARNING

Before performing any maintenance procedure or inspection, stop the engine, wait five (5) minutes to allow all parts to cool. Disconnect the spark plug wire, keeping it away from the spark plug.

| SYMPTOM | POSSIBLE CAUSE |
|--|---|
| <i>Operator Lever snapping out of gear or not staying in gear.</i> | <ul style="list-style-type: none"> ⇒ Lever not all the way forward when rack comes under full load. Push lever quicker and more forcefully into the full forward position. A hard stop should be felt at the end of the stroke when engaging the handle. ⇒ Stop bolt may be bent or not adjusted properly; contact us at www.DRpower.com for assistance. ⇒ Ram has been overloaded at lower part of face. Check rack gear for straightness. |
| <i>Rack slamming back too fast.</i> | <ul style="list-style-type: none"> ⇒ Wedge end of machine too high. Must be almost level with ram end or just slightly higher. ⇒ Springs not operating properly. Fix or replace as needed. |
| <i>Machine does not seem to have full splitting power.</i> | <ul style="list-style-type: none"> ⇒ The belt(s) may be too loose and slipping. Adjust or replace belt(s) as needed. |
| <i>Operator Lever not engaging rack with pinion gear.</i> | <ul style="list-style-type: none"> ⇒ Clean wood chips or other debris from under rack. ⇒ Clean accumulated dirt from frame where carriage assembly rests against rubber bumpers. |
| <i>Rack not disengaging from pinion when handle is released</i> | <ul style="list-style-type: none"> ⇒ Belts must be loosened to allow for slipping while disengaging |

Chapter 6: Parts Lists and Schematic Diagrams

Parts List - TOW BAR AND GUARD ASSEMBLY

NOTE: Part numbers listed are available through DR Power Equipment.

| <u>Ref#</u> | <u>Part#</u> | <u>Description</u> | <u>Ref#</u> | <u>Part#</u> | <u>Description</u> |
|-------------|--------------|--|-------------|--------------|--|
| 1 | 150431 | Bolt, HHCS, 3/8-16 X 1-1/4", GR5 | 17 | 352441 | Label, K34 Branding |
| 2 | 321041 | Bolt, Carriage, 3/8-16 X 1", GR5, ZP | | 352431 | Label, K28 Branding |
| 3 | 313631 | Table, Log | 18 | 333351 | Nut, Nylon Lock, Flanged, 1/2-13 |
| 4 | 333511 | Bolt, Hex, Flange, 3/8-16 X 1.25" | 19 | 333511 | Bolt, Hex, Flange, 3/8-16 X 1.25" |
| 5 | 333331 | Nut, Nylon Lock, Flanged, 3/8-16 | 20 | 333331 | Nut, Nylon Lock, Flanged, 3/8-16 |
| 6 | 333741 | Guard, Plastic, LH, W/ Warning Labels | 21 | 333531 | Bolt, Hex, Flange, 1/2-13 X 4" |
| 7 | 250441 | Label, Warning, Pinch Point, 3.5"x1" | 22 | 333481 | Bolt, Hex, Flange, 3/8-16 X 2.5" |
| 8 | 333611 | Label, Operation | 23 | 112391 | Washer, Flat, 3/8", USS |
| 9 | 333731 | Guard, Plastic, RH, W/ Warning Labels | 24 | 350891 | Bolt, HCS, 3/8-16 X 5.50", Full Thread, GR 5, ZP |
| 10 | 321281 | Label, Operation | | | |
| 11 | 367401 | Towbar | 25 | 365451 | Label, RapidFire Splitting Tips |
| 12 | 321051 | Mount, Tray | 26 | 376331 | Spacer, Cover |
| 13 | 321101 | Stand, Jack | 27 | 180811 | Washer, Lock, 3/8" |
| 14 | 187371 | Pin, Clevis, 1/2" OD X 4.5" LG | 28 | 112411 | Washer, Flat, 5/16", USS, ZP |
| 15 | 160031 | Pin, Hair, 1/2" To 9/16", .12" Wire | | | |
| 16 | 189671 | Washer, Flat, Neoprene, .490"ID X 1.06"OD X .09"TH | | | |

Schematic – TOW BAR AND GUARD ASSEMBLY

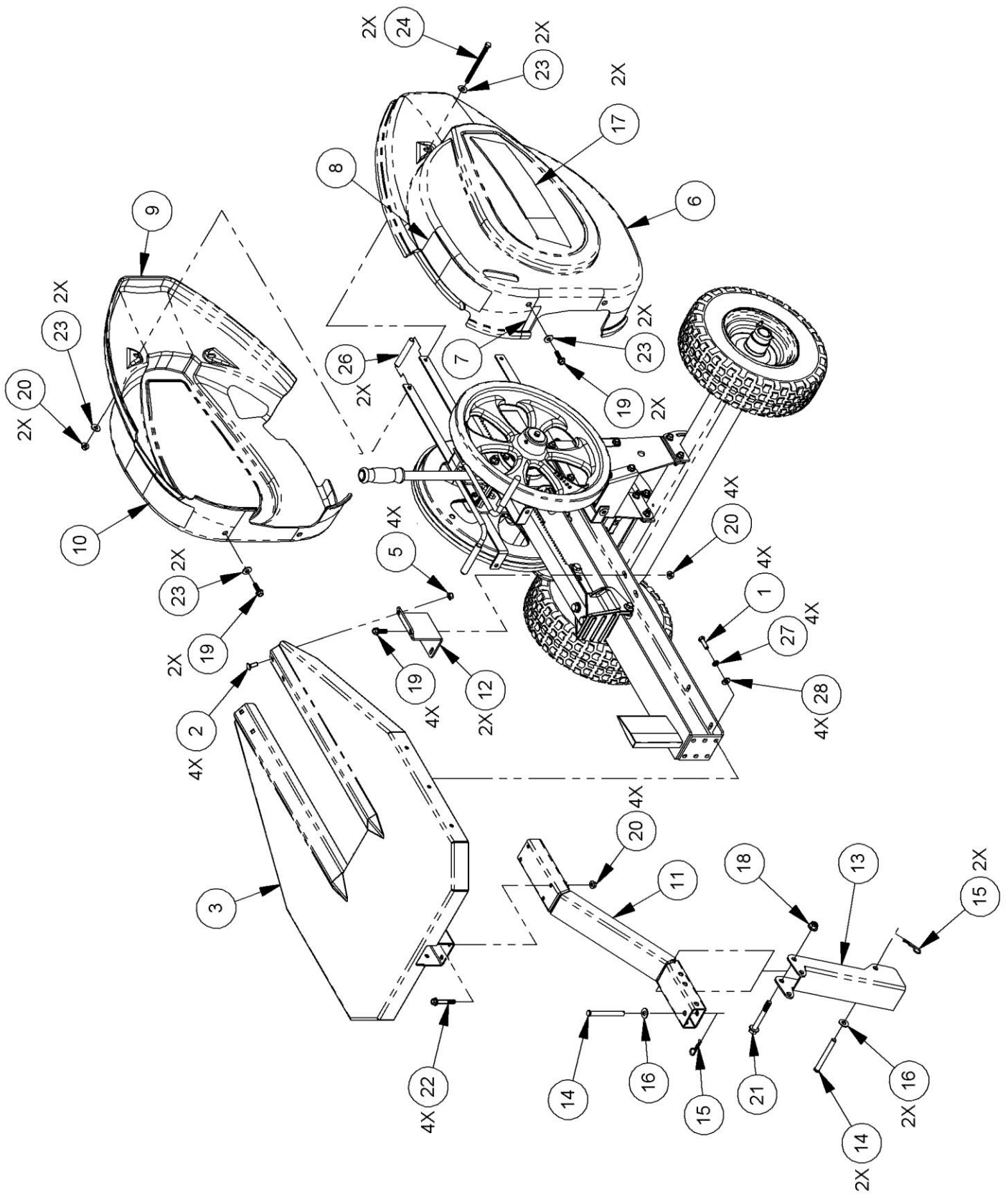

Parts List – DRIVE ASSEMBLY

NOTE: Part numbers listed are available through DR Power Equipment.

| Ref# | Part# | Description | Ref# | Part# | Description |
|------|--------|---|------|--------|---|
| 1 | 294611 | Flywheel, 75 Lb (K34) | 20 | 321141 | Pulley, 2 Groove, 4l, 3/4" Keyway |
| | 321251 | Flywheel, 55 Lb (K28) | 21 | 333561 | Belt, 4l700 |
| 2 | 370751 | Engine, B&S, 9.50 XR, E/S, W/Labels | 22 | 294981 | Cylinder, Bumper |
| | 370761 | Engine, B&S, 9.50 CR, M/S, W/Labels | 23 | 321261 | Bracket, Return, Stop |
| | 370771 | Engine, B&S, 7.50 CR, M/S, W/Labels | 24 | 321221 | Washer, 5/16" ID, 2.0" OD, 0.13" T |
| 3 | 294871 | Boot, Terminal, Red | 25 | 123361 | Bolt, HHCS, 5/16-18 X 1.25", GR.5, ZP |
| 4 | 312831 | Nut, Lock Serrated Flange, 1/4-20 | 26 | 111521 | Bolt, HHCS, .375-16 X 1.00" Lg. |
| 5 | 294941 | Key, Square, 3/8" X 3/8" X 1.5" L | 27 | 333581 | Bolt, Hex, Flange, M12-1.75 x 50, CL 8.8, ZP |
| 6 | 294931 | Screw, Set, Cup Point, 3/8 X 16 X .5 L | 28 | 312381 | Bolt, HCS, 1/2-20 X 2.5", GR8, ZP |
| 7 | 294541 | Gear, Pinion | 29 | 234991 | Washer, SAE Flat, 1/2", ZP |
| 8 | 275751 | Key, Square, 3/16" X 3/16" - 1/2" | 30 | 333511 | Bolt, Hex, Flange, 3/8-16 X 1.25" |
| 9 | 279011 | Washer, Flat, 3/8" X 1.25" X .25", ZP | 31 | 333521 | Bolt, Hex, Flange, 5/16-18 X 1.5" |
| 10 | 112431 | Washer, Lock, Split, 5/16" | 32 | 333321 | Nut, Nylon Lock, Flanged, 5/16-18 |
| 11 | 178821 | Bolt, HCS, 5/16-24 x 1", GR2 ZP | 33 | 333331 | Nut, Nylon Lock, Flanged, 3/8-16 |
| 12 | 294551 | Housing, Bearing | 34 | 187551 | Nut, Nylon Lock, 5/16-18, LP |
| 13 | 294561 | Insert Bearing W/ Snap Ring | 35 | 134431 | Bolt, HCS, 5/16-18 X 1-1/2", GR5, ZP |
| 14 | 313561 | Mount, Engine | 36 | 112421 | Washer, Lock, 0.5" |
| 15 | 321111 | Bearing, 6301, 12mm ID, 37mm OD, 12mm W | 37 | 302531 | Nut, Nylon Lock, M12-1.75 |
| 16 | 321071 | Ram | 38 | 333541 | Bolt, HCS, M12-1.75 x 30, CL 8.8, ZP |
| 17 | 294591 | Gear, Rack | 39 | 333461 | Bushing, Bronze, 0.5" ID, 0.625" OD, 0.375" L |
| 18 | 294681 | Spring, Compression, Carriage | 40 | 111581 | Bolt, HCS, 5/16-18 X 1", GR5, ZP |
| 19 | 320991 | Bracket, Rack, Lifter | | | |

Schematic – DRIVE ASSEMBLY

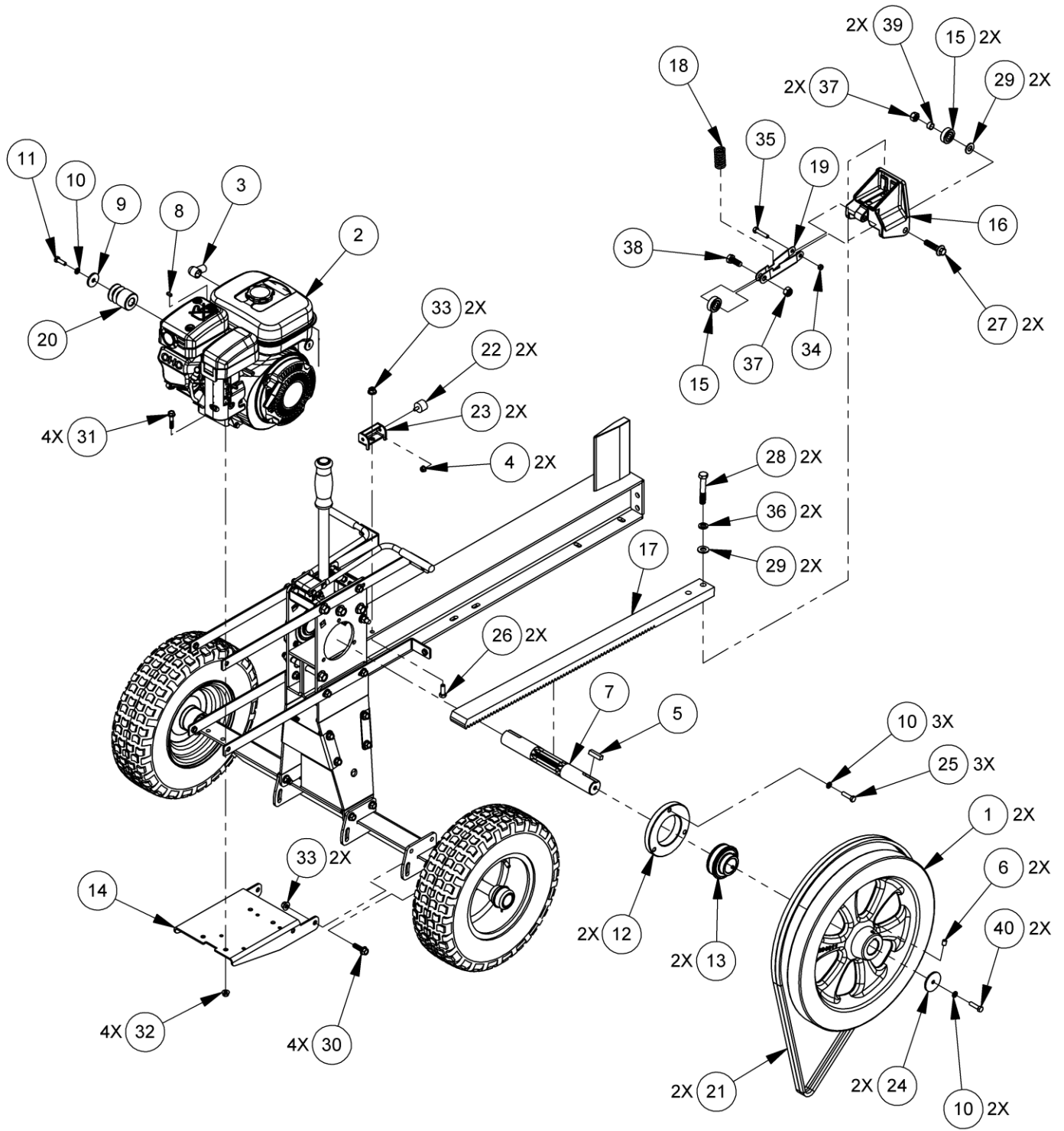

Parts List – FRAME AND AXLE ASSEMBLY

NOTE: Part numbers listed are available through DR Power Equipment.

| <u>Ref#</u> | <u>Part#</u> | <u>Description</u> | <u>Ref#</u> | <u>Part#</u> | <u>Description</u> |
|-------------|--------------|--------------------------------------|-------------|--------------|--|
| 1 | 313571 | Frame, Main | 24 | 112421 | Washer, Lock, 0.5" |
| 2 | 134471 | Battery, 12V, 9Ah | 25 | 109481 | Cap, Round, 1" |
| 3 | 114681 | Bolt, HHCS, 1/4-20 X 2.0", GR2, ZP | 26 | 352161 | Bracket, Cover, Mounting |
| 4 | 295071 | Harness, Wire | 27 | 333311 | Nut, Nylon Lock, Flanged, 1/4-20 |
| 5 | 320941 | Support, Axle | 28 | 333491 | Bolt, Hex, Flange, 1/2-13 X 5" |
| 6 | 313621 | Axle | 29 | 333511 | Bolt, Hex, Flange, 3/8-16 X 1.25" |
| 7 | 252971 | Wheel & Tire Assembly, w/Dust Cap | 30 | 333501 | Bolt, Hex, Flange, 3/8-16 X 2" |
| 8 | 253181 | Dust Cap | 31 | 352371 | Bushing, Roller |
| 9 | 126831 | Nut, 3/8-16, ZP | 32 | 353591 | Nut, Hex, Jam, 1/2-13, GR5, ZP |
| 10 | 313741 | Brace, Axle | 33 | 365531 | Bolt, HCS, 1/2-13 x 2", Partial Thd, GR8 |
| 11 | 321061 | Catch, Handle Engagement | 34 | 286971 | Pad, Battery 2.5" X 6.125" |
| 12 | 321091 | Lever, 2 Hand | 35 | 333331 | Nut, Nylon Lock, Flanged, 3/8-16 |
| 13 | 101891 | Grease Fitting 1/4-28 Straight | 36 | 333351 | Nut, Nylon Lock, Flanged, 1/2-13 |
| 14 | 180811 | Washer, Lock, 3/8" | 37 | 352381 | Bracket, Control Interface |
| 15 | 253111 | Pin, Cotter, 5/32" x 2" | 38 | 352251 | Yoke, Handle |
| 16 | 112411 | Washer, Flat, 5/16", USS, ZP | 39 | 352231 | Handle |
| 17 | 110221 | Grip, Shift Handle | 40 | 352241 | Link, Handle |
| 18 | 231031 | Bolt, Carr, 3/8-16 x 1 3/4", GR5, ZP | 41 | 352401 | Spring, Torsion |
| 19 | 320981 | Bushing, Bronze, SAE 954 | 42 | 353581 | Bolt, Hex Tap Bolt, Fully Threaded, 3/8-16 X 3-1/2", GR8, ZP |
| 20 | 333551 | Grip, Foam, 1" Tube, 5.1" Long | 43 | 229091 | Bolt, HCS, 1/2-13 X 1-1/2", GR5, ZP |
| 21 | 180851 | Bolt, HCS, 1/4-20 x 2.75" | 44 | 345121 | Bolt, Hex, Flange, 3/8-16 X .75", GR5, ZP |
| 22 | 253101 | Nut, Hex, Slotted | 45 | 242301 | Strap, Battery |
| 23 | 294711 | Spring, Extension, Carriage Return | | | |

Schematic – FRAME AND AXLE ASSEMBLY

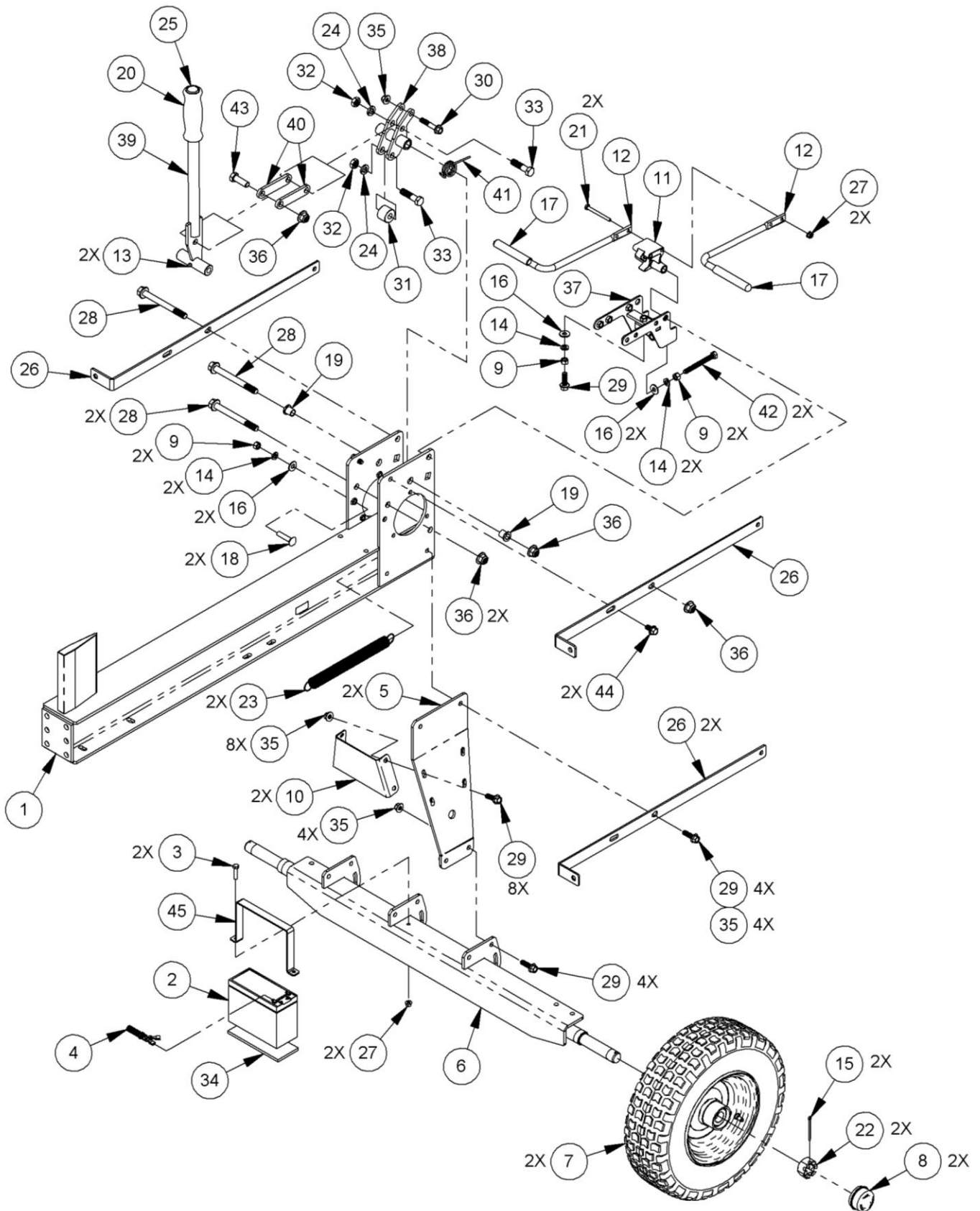

DR[®] RAPIDFIRE™ LOG SPLITTER



2-Year Limited Warranty

Terms and Conditions

The DR[®] RAPIDFIRE™ Log Splitter is warranted for two (2) years against defects in materials or workmanship when put to ordinary and normal consumer use; 90 days for commercial use. The engine manufacturer warrants the engine separately.

For the purposes of all the above warranties, "ordinary and normal use" does not include misuse, accidents or damage due to inadequate maintenance.

DR[®] Power Equipment certifies that the DR[®] RAPIDFIRE™ Log Splitter is fit for ordinary purposes for which a product of this type is used. DR[®] Power Equipment however, limits the implied warranties of merchantability and fitness in duration to a period of two (2) years in consumer use; 90 days for commercial use.

The 2-Year Limited Warranty on the DR[®] RAPIDFIRE™ Log Splitter starts on the date the machine ships from our factory. The 2-Year Limited Warranty is applicable only to the original owner.

The warranty holder is responsible for the performance of the required maintenance as defined by the manufacturer's owner's manuals. The warranty holder is responsible for replacement of normally wearing parts such as the Drive Belts, Air Filter, Highway Wheels, Battery, and Spark Plug. Accessories to the machine are not covered by this warranty.

During the warranty period, the warranty holder is responsible for the machine transportation charges, if required. During the warranty period, warranty parts will be shipped by standard method at no charge to the warranty holder. Expedited shipping of warranty parts is the responsibility of the warranty holder.

SOME STATES DO NOT ALLOW LIMITATIONS ON THE LENGTH OF IMPLIED WARRANTIES, SO THE ABOVE LIMITATIONS MAY NOT APPLY TO YOU.

DR[®] Power Equipment shall not be liable under any circumstances for any **incidental or consequential damages or expenses** of any kind, including, but not limited to, cost of equipment rentals, loss of profit, or cost of hiring services to perform tasks normally performed by the DR[®] RAPIDFIRE™ Log Splitter.

SOME STATES DO NOT ALLOW THE EXCLUSION OR LIMITATION OF INCIDENTAL OR CONSEQUENTIAL DAMAGES, SO THE ABOVE LIMITATIONS MAY NOT APPLY TO YOU.

THIS WARRANTY GIVES YOU SPECIFIC LEGAL RIGHTS, AND YOU ALSO HAVE OTHER RIGHTS, WHICH VARY FROM STATE TO STATE.

Daily Checklist for the DR LOG SPLITTER

To help maintain your DR LOG SPLITTER for optimum performance, we recommend you follow this checklist each time you use your Log Splitter.

WARNING

Before performing any maintenance procedure or inspection, stop the engine, wait five (5) minutes to allow all parts to cool. Disconnect the spark plug wire, keeping it away from the spark plug.

- [] Check the Engine Oil and Gas Tank level.
- [] Check that Engine is clean of debris.
- [] Check the general condition of the Log Splitter, e.g.; Nuts, Bolts, Welds, etc.
- [] Check Tire Pressure and wear.
- [] Check the Frame for wear and damage.
- [] Check the Wedge for nicks and wear. Sharpen if needed.
- [] Apply a rust preventative (Fluid Film or equivalent) to any bare metal areas on the top of the Rail. This will assure the longest possible service life of the Wear Pads.

End of Season and Storage

WARNING

Before performing any maintenance procedure or inspection, stop the engine, wait five (5) minutes to allow all parts to cool. Disconnect the spark plug wire, keeping it away from the spark plug.

- Change the Engine Oil.
- Clean or replace the Air Filter.
- Check the Wedge for nicks and wear. Sharpen if needed.
- Apply a rust preventative to the Rack and Pinion (fluid film or equivalent).
- Apply a rust preventative (Fluid Film or equivalent) to any bare metal areas on the top of the Rail.
- If your DR RAPIDFIRE LOG SPLITTER will be idle for more than 30 days, we recommend using a gas stabilizer. This will prevent sediment from gumming up the Carburetor. If there is dirt or moisture in the gas or Tank, remove it by draining the Tank. Completely fill the Tank with fresh, unleaded gas and add the appropriate amount of stabilizer or gasoline additive. Run the Engine for a short time to allow the additive to circulate.
- Clean the exterior of the unit to remove all dirt, grease, and any other foreign material. Clean dirt and debris from the Cylinder Head Cooling Fins and Muffler area of the Engine. To prevent rust, touch up painted surfaces that have been scratched or chipped.
- Be sure all Nuts, Bolts, and Screws are securely fastened.
- Remove the Spark Plug(s) and pour about 1 ounce of Motor Oil into the Cylinder hole. Replace the Plug(s) and crank the Engine over a couple of times using the Pull Cord, or the Electric Starter (for Electric Start Machines). This will coat the Piston and seat the Valves to prevent moisture buildup.
- If possible, store the Log Splitter in a dry, protected place. If it is necessary to store the Log Splitter outside, cover it with a protective material (especially the Engine). For Electric Start Model, store the machine in a dry environment with temperatures between +40°F (5°C) and +95F (+35°C). Make sure the storage temperatures will never be outside of these limits. The lower the storage temperature is within the specified temperature, the better as the Battery will discharge more slowly at low temperatures. If it is necessary to store the Log Splitter outside, make sure to disconnect the Battery and store it in an environment as listed above. Make sure the disconnected Battery terminals are not resting on any surface that may be prone to collecting water, snow or any other liquid as this may cause damage to the Terminals and to the Battery when reconnected.



800 HINESBURG ROAD, SOUTH BURLINGTON, VERMONT 05403