

DR® WIDE-CUT LAWN MOWER



Safety & Operating Instructions

Models:

SP26

SP30



Serial No. _____

Order No. _____

DR Power Equipment
Toll-free phone: 1-800-DR-OWNER (376-9637)
Fax: 1-802-951-8497
Website: www.DRpower.com

WARNING

Read and understand this manual and all instructions before operating the DR WIDE-CUT LAWN MOWER

Table of Contents

Chapter 1: General Safety Rules..... 4
Chapter 2: Setting Up the DR WIDE-CUT LAWN MOWER 8
Chapter 3: Operating the DR WIDE-CUT LAWN MOWER 12
Chapter 4: Maintaining the DR WIDE-CUT LAWN MOWER..... 16
Chapter 5: Troubleshooting 23
Chapter 6: Parts Lists and Schematic Diagrams..... 26

Conventions used in this manual

DANGER

This indicates a hazardous situation which, if not followed, will result in death or serious injury.

WARNING

This indicates a hazardous situation which, if not avoided, could result in death or serious injury.

CAUTION

This indicates a hazardous situation which, if not avoided, could result in minor or moderate injury.

NOTICE

This information is important in the proper use of your machine. Failure to follow this instruction could result in damage to your machine or property.

Serial Number and Order Number

A Serial Number is used to identify your machine and is located on the Serial Number Label on your machine. An Order Number is used to check and maintain your order history and is located on your packing slip. For your convenience and ready reference, enter the Serial Number and Order Number in the space provided on the front cover of this manual.

Additional Information and Potential Changes

DR Power Equipment reserves the right to discontinue, change, and improve its products at any time without notice or obligation to the purchaser. The descriptions and specifications contained in this manual were in effect at printing. Equipment described within this manual may be optional. Some illustrations may not be applicable to your machine.

California Proposition 65

 **WARNING**
CANCER AND REPRODUCTIVE HARM - www.P65Warnings.ca.gov.

Chapter 1: General Safety Rules

WARNING

Read this safety & operating Instructions manual before you use the DR WIDE-CUT LAWN MOWER. Become familiar with the operation and service recommendations to ensure the best performance from your machine. If you have any questions or need assistance, please contact us at www.DRpower.com or call toll-free 1-800-DR-OWNER (376-9637) and one of our Technical Support Representatives will be happy to help you.

Labels

Your DR WIDE-CUT LAWN MOWER carries prominent labels as reminders for its proper and safe use. Shown below are copies of all the Safety and Information labels that appear on the equipment. Take a moment to study them and make a note of their location on your Mower as you set up and before you operate the unit. Replace damaged or missing safety and information labels immediately.



#A0000213836



#136491



#325431

ONE-TOUCH HEIGHT ADJUSTMENT

322401

#322401

**WARNING: Check Oil
Before Starting Engine**

#137581

**HANDLEBAR
ADJUSTMENT**

Hold Handlebar While Adjusting

#A0000203118

 WARNING

**Only use DR Power
replacement belts/parts.**

Contact us at 802-877-1200
or visit us at drpower.com

#A0000247447

Protecting Yourself and Those Around You

WARNING

This is a high-powered machine, with moving parts operating with high energy. You must operate the machine safely. Unsafe operation can create a number of hazards for you, as well as anyone else in the nearby area. Always take the following precautions when using this machine:

- Keep in mind that the operator or user is responsible for accidents or hazards occurring to other people, their property, and themselves.
 - Always wear protective goggles or safety glasses with side shields while using the Mower to protect your eyes from possible thrown debris.
 - Avoid wearing loose clothing or jewelry, which can catch on moving parts.
 - We recommend wearing gloves while using the Mower. Be sure your gloves fit properly and do not have loose cuffs or drawstrings.
 - Wear shoes with non-slip treads when using your Mower. If you have safety shoes, we recommend wearing them. Do not use the machine while barefoot or wearing open sandals.
 - Wear long pants while operating the Mower.
 - Use ear protectors or ear plugs rated for at least 20 dba to protect your hearing.
 - Keep bystanders at least 100 feet away from your work area at all times. Release the Blade Control Bar to stop the engine and the Blade when another person or pet approaches.
-

Safety for Children and Pets

WARNING

Tragic accidents can occur if the operator is not alert to the presence of children and pets. Children are often attracted to the machine and the mowing activity. *Never* assume that children will remain where you last saw them. Always follow these precautions:

- Keep children and pets at least 100 feet from the working area and ensure they are under the watchful care of a responsible adult.
 - Be alert and turn the machine off if children or pets enter the work area.
 - Never allow children to operate the Mower.
 - Use extra care when approaching blind corners, shrubs, trees, or other objects that may block your view of a child or pet.
-

Safety with Gasoline - Powered Machines

WARNING

Gasoline is a highly flammable liquid. Gasoline also gives off flammable vapor that can be easily ignited and cause a fire or explosion. Never overlook the hazards of gasoline. Always follow these precautions:

- Never run the engine in an enclosed area or without proper ventilation as the exhaust from the engine contains carbon monoxide, which is an odorless, tasteless, and deadly poisonous gas.
 - Store all fuel and oil in containers specifically designed and approved for this purpose and keep away from heat and open flame, and out of the reach of children.
 - Replace rubber fuel lines and grommets when worn or damaged and after 5 years of use.
 - Fill the gasoline tank outdoors with the engine off and allow the engine to cool completely. Don't handle gasoline if you or anyone nearby is smoking, or if you're near anything that could cause it to ignite or explode. Never overfill the tank and reinstall the fuel tank Cap and fuel container cap securely.
 - The engine exhaust from this product contains chemicals known to the State of California to cause cancer, birth defects, or other reproductive harm.
-

WARNING

- If you spill gasoline, do not attempt to start the engine. Move the machine away from the area of the spill and avoid creating any source of ignition until the gas vapors have dissipated. Wipe up any spilled fuel to prevent a fire hazard and properly dispose of the waste. If fuel is spilled on clothing, change clothing immediately.
- Allow the engine to cool completely before storing in any enclosure. Never store a machine that has gas in the tank, or a fuel container, near an open flame or spark such as a water heater, space heater, clothes dryer, or furnace.
- Never make adjustments or repairs with the engine running. Shut down the engine, disconnect the spark plug wire, keeping it away from the spark plug to prevent accidental starting, wait 5 minutes before making adjustments or repairs.
- Never tamper with the engine's governor setting. The governor controls the maximum safe operation speed and protects the engine. Over-speeding the engine is dangerous and will cause damage to the engine and to the other moving parts of the machine.
- Keep combustible substances away from the engine when it is hot.
- Never cover the machine while the muffler is still hot.
- Do not operate the engine with the air cleaner or the carburetor air intake cover removed. Removal of such parts could create a fire hazard. Do not use flammable solutions to clean the air filter.
- The muffler and engine become very hot and can cause a severe burn; do not touch.
- Never fill containers inside a vehicle or on a truck or trailer bed with a plastic liner. Always place containers on the ground away from your vehicle before filling.
- Remove gas-powered equipment from the truck or trailer and refuel it on the ground. If this is not possible, then refuel such equipment with a portable container rather than from a gasoline dispenser nozzle.
- Keep the nozzle in contact with the rim of the fuel tank or container opening at all times until fueling is complete. Do not use a nozzle lock- open device.

General Safety

WARNING

Operating this Mower safely is necessary to prevent or minimize the risk of death or serious injury. Unsafe operation can create a number of hazards for you. This Mower is capable of amputating hands and feet and throwing objects. Always take the following precautions when operating this Mower:

- Your Mower is a powerful tool, not a plaything. Exercise extreme caution at all times. The machine is designed to mow grass. Do not use it for any other purpose.
- Ensure that the Mower is located flat on a level and clean area of lawn before starting.
- Know how to stop the Mower quickly; see "stopping the engine" in chapter 3.
- Never operate your unit on a slippery, wet, muddy, or icy surface. Exercise caution to avoid slipping or falling.
- Always walk when mowing, never run.
- Stop the blade when crossing surfaces other than grass, and when transporting the lawnmower to and from the area to be mowed.
- See manufacturer's instructions for proper operation and installation of accessories. Only use accessories approved by DR Power Equipment.
- Never use the machine without ensuring that all guards and shields are in place.
- Never, under any conditions, remove, bend, cut, fit, weld, or otherwise alter standard parts on the Mower. This includes all shields and guards. Modifications to your machine could cause personal injuries and property damage and will void your warranty.
- Clear the area of objects such as rocks, wire, toys, etc., which could be thrown by the blade.
- Keep hands and feet clear of the discharge opening at all times and only operate the Mower from the operator position behind the handlebars.
- Allow only one person to operate the Mower at any time.
- Never direct discharged material toward anyone. Avoid discharging material against a wall or obstruction. Material may ricochet back toward the operator.
- Do not pull machine backward unless absolutely necessary. Always look down and behind before and while moving backward.

! WARNING

- If the machine should start making an unusual noise or vibration, stop the engine, wait five minutes to allow all parts to cool. Disconnect the spark plug wire, keeping it away from the spark plug, then inspect for damage. Vibration is generally a warning of trouble. Check for damaged parts and clean, repair, and/or replace as necessary.
 - Never tamper with safety devices. Check their proper operation regularly.
 - Before performing any maintenance procedure or inspection, stop the engine, wait five minutes to allow all parts to cool. Disconnect the spark plug wire, keeping it away from the spark plug.
 - Never allow people who are unfamiliar with these instructions to use the Mower. Allow only responsible individuals who are familiar with these rules of safe operation to use your machine.
 - Never overload or attempt to mow material beyond the manufacturer's recommendation. Personal injury or damage to the machine could result.
 - While using the Mower, don't hurry or take things for granted. When in doubt about the equipment or your surroundings, stop the machine and take the time to look things over.
 - Never operate the machine when under the influence of alcohol, drugs, or medication.
 - Use the machine only in daylight.
 - Keep all nuts and bolts tight and keep the equipment in good operating condition.
-

A Note to All Users

Under California law, and the laws of some other states, you are not permitted to operate an internal combustion engine using hydrocarbon fuels without an engine spark arrester. This also applies to operation on US Forest Lands. All DR WIDE-CUT LAWN MOWERS shipped to California, New Mexico, Oregon, and Arizona are equipped with spark arresters. Failure of the owner or operator to maintain this equipment in compliance with state regulations is a misdemeanor under California law and may be in violation of other state and/or federal regulations. Contact your State Park Association or the appropriate state organization for specific information in your area.

No list of warnings and cautions can be all-inclusive. If situations occur that are not covered by this manual, the operator must apply common sense and operate this DR WIDE-CUT LAWN MOWER in a safe manner. Contact us at www.DRpower.com or call 1-800-DR-OWNER (376-9637) for assistance.

Chapter 2: Setting Up the DR WIDE-CUT LAWN MOWER

It may be helpful to familiarize yourself with the controls and features of your DR WIDE-CUT LAWN MOWER as shown in **Figure 1** before beginning these procedures. If you have any questions at all, please feel free to contact us at www.DRpower.com.

DR WIDE-CUT LAWN MOWER Controls and Features

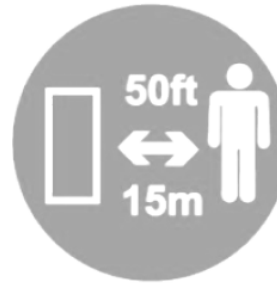

Figure 1

Pictogram Descriptions



Avoid steep slopes when using this mower. Use caution on all slopes. Mow across slopes rather than up and down. Do not use the Mower on slopes greater than 20 degrees. Doing so could result in serious injury or damage to your machine.



Keep bystanders 50 feet away from your work area at all times. Debris exits the machine at great speeds. To be safe, do not operate the machine near small children or pets, and never allow children to operate the machine. Stop the engine when another person or pet approaches.



Keep your Hands away from moving parts. Never reach under the deck or into the discharge openings. **SERIOUS INJURY OR DEATH** may occur.



Use ear protectors or ear plugs rated for at least 20 dba to protect your hearing. Always wear protective goggles or safety glasses with side shields while chipping to protect your eyes from possible thrown debris.



Machine may discharge debris at great speeds. Keep area of discharge clear of people, animals, buildings, glass, or anything else that will obstruct clear discharge, cause injury, or damage. Wind can also change discharge direction, so be aware.



Look behind when backing up the mower. Avoid pulling the mower backward except when necessary.



Keep all guards and safety devices in place and functional. Do not disable or remove guards, safety interlocks, or other protective devices.



Read this safety & operating Instructions manual before you use the machine. Become familiar with the operation and service recommendations to ensure the best performance.

Specifications

Engine	See Engine Manufacturers Manual for detailed Engine information
Cutting Width	26" (SP26), 30" (SP30)
Cutting Height	8 Heights, 1" min to 4" max
Deck Material	Cast Aluminum
Wheel Size	8" x 2" Front, 10" x 3" Rear
Dimensions	67" L x 28" W x 42" H (SP26), 72" L x 32" W x 42" H (SP30)
Weight	30" E/S - 125lbs, 30" M/S - 117lbs, 26" E/S - 111lbs, 26" M/S - 101lbs

Parts Supplied in Shipping Box:

Mulching Plug (shipped inside mower housing)
Discharge Deflector
Bagger Assembly
Mower Assembly

Compare the contents of the Shipping Box with the "Parts Supplied" list above. If you have any questions please contact us at www.DRpower.com or call 1-800-DR-OWNER (376-9637) for assistance.

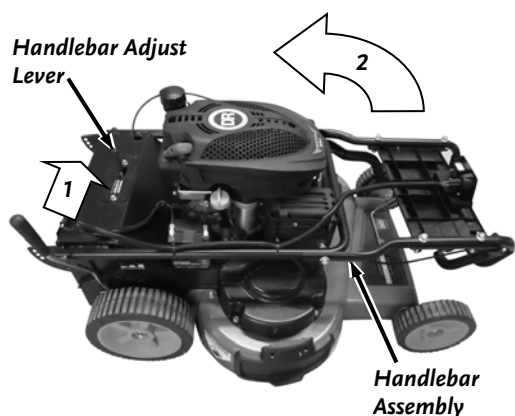

Figure 2

Unfolding the Handlebars

1. Move the Handlebar Adjust Lever to the left to release the Handlebar (**Figure 2**).
2. Hold the Lever as you pull up on the Handlebar Assembly.
3. Release the Lever when you are near the desired position and continue rotating the Handlebar until the pins lock into the holes in the side of the Frame.

Adding Oil and Gasoline

Engine Oil	SAE 30: above 40 degrees F; 10w-30: 10-90 degrees F; 5w-30: 40 degrees F or below
Fuel	Unleaded gasoline

Note: Refer to the Engine Manufacturers Manual for more detailed Engine information.

NOTICE

- You must add oil before starting the engine. This machine is shipped without oil. Traces of oil may be in the reservoir from factory testing, but **you must add oil before starting the engine**. Fill the reservoir slowly, checking the level frequently to avoid overfilling.
- To get an accurate reading when checking the oil level:
 - The machine should be on a level surface.
 - To ensure an accurate oil level reading, insert the Dipstick into the filler hole with Cap resting on top, but do not screw it down.

Tip: To avoid confusion, we recommend leaving the caps on the Fuel and Oil Fills until you are ready to pour either gasoline or oil into the correct Fill.

Note: You will need approximately 17 to 20 ounces of high detergent oil depending on Engine type. Use only high detergent oil classified "For Service SF, SG, SH, SJ" or higher. Do not use special additives. Other types of oil could cause problems with the operation of your machine. Please refer to your Engine Owner's Manual provided with your mower for detailed information on oil quantity and cold temperature oil specifications.

1. Place the machine on a level surface remove the Oil Fill/Dipstick (**Figure 3**).
2. Machines are shipped with no oil. Initially add 17 to 20oz. of the oil recommended by the Engine Manufacturer. Wait one minute for the oil to settle.
3. Insert the Oil Fill/Dipstick into the hole but do not screw it on all the way. Remove the Dipstick and check the oil level (**Figure 4**). Clean the Dipstick with the rag after checking.
4. Continue adding a few ounces of oil at a time, rechecking the Oil Fill/Dipstick until the oil reaches the fill mark. Be careful not to overfill.
5. Replace the Dipstick and screw all the way on when full.



Figure 3

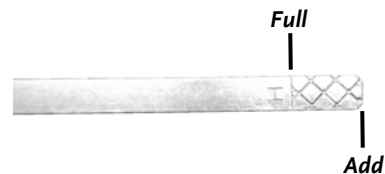

Figure 4

⚠ WARNING

Gasoline is extremely flammable and explosive. A fire or explosion from gasoline can burn you and others.

- To prevent static electricity from igniting the gasoline, place the container and/or mower directly on the ground before filling, not in a vehicle or on an object.
- Fill the tank outdoors when the engine is cold. Wipe up spills.
- Do not handle gasoline when smoking or around an open flame or sparks.
- Store gasoline in an approved fuel container, out of the reach of children.

6. Remove the Gas Fill Cap and fill the Gas Tank with fresh, unleaded gas (with a minimum of 85 Octane) to approximately 1" to 1-1/2" below the top of the fill neck to allow for fuel expansion (**Figure 5**). Be careful not to overfill and reinstall the Gas Fill Cap before starting the engine. See your Engine Owner's Manual for more detailed information.

Note: To refill the gas tank, turn the engine OFF and let the engine cool at least five minutes before removing the gas fill cap.



Figure 5

Connecting the Battery Wire Harness (Electric Start Models)

1. Plug the Negative Battery Wire onto the Negative Battery Terminal (**Figure 6**).



Figure 6

Chapter 3: Operating the DR WIDE-CUT LAWN MOWER

It may be helpful to better familiarize yourself with the features of your Mower by reviewing **Figure 1** in Chapter 2 before beginning the steps outlined in this chapter.

! WARNING

Read and understand all warnings listed in “Chapter 2 General Safety Rules” before operating this Mower.

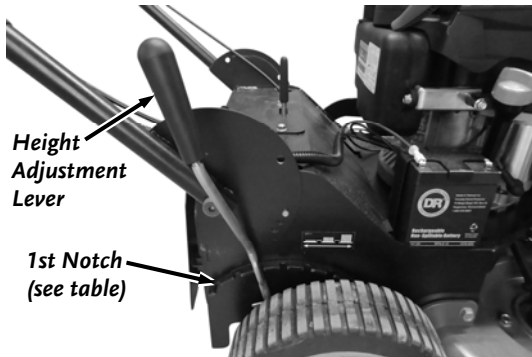

Figure 7

Adjusting the Cutting Height

! WARNING

Adjusting the cutting height may bring you into contact with the mowing blade causing serious injury.

- Stop the engine and wait for all moving parts to stop.
- Do not put your fingers under the housing when adjusting the cutting height.

Use the Height Adjustment Lever to set all four Wheels to the same cutting height as desired (**Figure 7**). Pull Lever outward, move Lever to desired position, and release Lever to lock in notch.

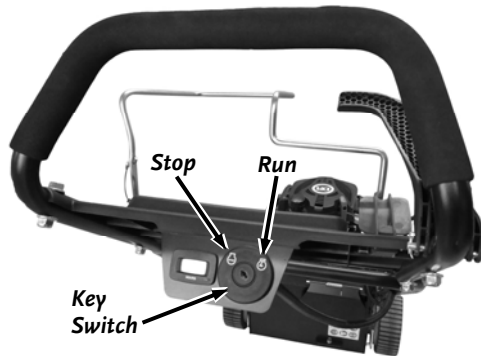

Figure 8

Notch Position	Cutting Height
1st: Fully towards rear of mower	1.0 inch (2.5 cm)
2nd:	1.5 inch (3.8 cm)
3rd:	2 inch (5.1 cm)
4th:	2.4 inch (6.1 cm)
5th:	2.9 inch (7.4 cm)
6th:	3.4 inch (8.6 cm)
7th:	3.7 inch (9.4 cm)
8th: Fully towards front of mower	4 inch (10.2 cm)

Starting the Engine

Note: Your DR Engine has a fixed Throttle position and is equipped with an Auto-Choke. No Throttle or Choke adjustment is required by the operator.

Manual Start

1. Turn the Key to the “RUN” position (**Figure 8**).
2. Grasp the Recoil Starter Handle and pull slowly until resistance is felt, then pull rapidly to overcome engine compression and to prevent kick back to start the engine (**Figure 9**).

Note: When starting the engine for the first time or if the engine has run out of fuel, it will take extra cranking time to move fuel from the tank to the engine.



Figure 9

Electric Start

1. Stand behind the Mower and turn the Key Switch to the “Start” position to start the engine (**Figure 10**). As soon as the Engine starts, release the Key and it will return to the “RUN” position.

Note: When starting the engine for the first time or if the engine has run out of fuel, it will take extra cranking time to move fuel from the tank to the engine.

Stopping the Engine

1. Turn the Key to the “STOP” position (**Figure 10**).

Engaging the Blades

1. Push the 2 Step Lever down (1) against the Handlebar Console (**Figure 11**).
2. Pull the Blade Engage Bail Bar against the Handlebar Grip (2).

Stopping the Blades

1. Release the Blade Engage Bail Bar (**Figure 12**).

WARNING

When you release the blade engage bail bar the blade should stop within 3 seconds. If it does not stop properly, shut the mower off immediately and contact us at www.DRpower.com or call toll-free 1-800-DR-OWNER (376-9637).

Forward Travel

TO TRAVEL FORWARD

Note: Do not pull mower backward when the Self-Propel Drive Lever is engaged.

1. Start the machine and slowly pull the Self Propel Drive Lever toward the Handlebar Grip and hold for maximum speed as needed (**Figure 13**).

Note: You can vary the speed of the machine by the position of the Drive Lever. Pulling the Drive Lever fully against the Handlebar Grip produces the maximum travel speed. Slowly releasing the Drive Lever will produce lower speeds until the Lever is fully released to stop forward travel.

TO STOP TRAVEL FORWARD

1. Fully release the Drive Lever (**Figure 13**).

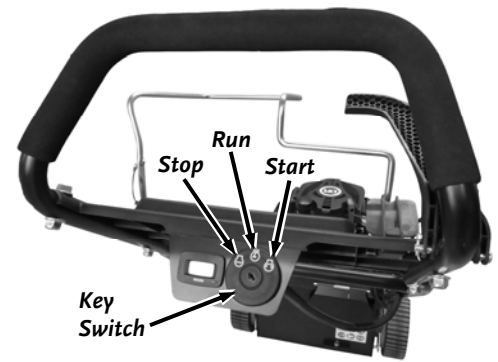

Figure 10

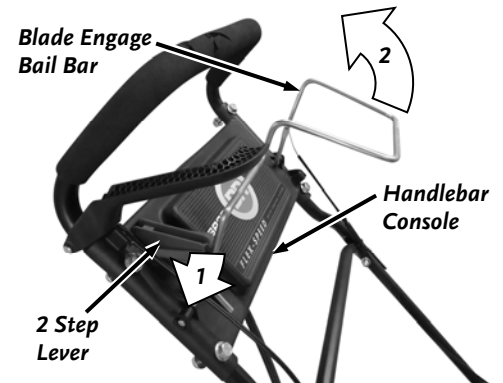

Figure 11



Figure 12



Figure 13

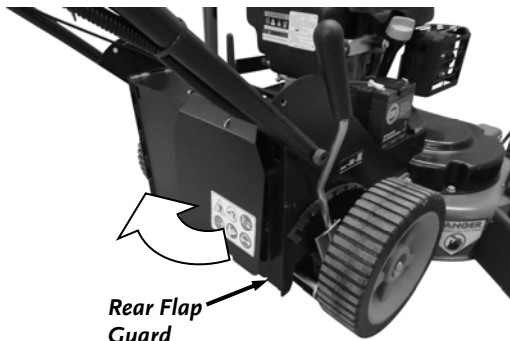

Figure 14

Setting up for rear Bagger discharge

1. Lift the Rear Flap Guard (*Figure 14*).
1. Remove the Mulching Plug (*Figure 15*).
1. Hold the Discharge Guard in the upright position as you place the tabs of the Bagger Assembly into the slots in the rear Frame on both sides (*Figure 16*).
2. Lower the Rear Flap Guard onto the Bagger Assembly.
3. Ensure the Discharge Deflector is removed and the Side Discharge Guard is down (*Figure 17*).

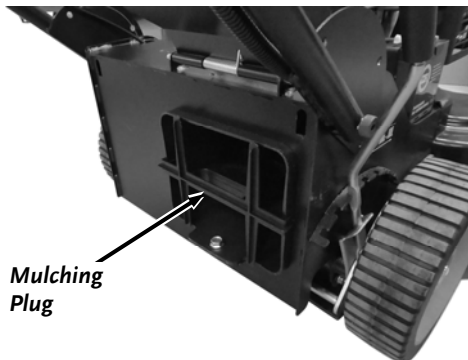

Figure 15

Setting up for Mulching

1. Ensure the Discharge Deflector is removed and the Side Discharge Guard is down (*Figure 17*).
2. Install the Mulching Plug (*Figure 15*).

Setting up for side discharge

1. Install the Mulching Plug (*Figure 15*).
2. Lift the Side Discharge Guard (*Figure 17*) to access to the Pivot Rod (*Figure 18*).
3. Insert the Discharge Deflector tabs under the Pivot Rod.
4. Lower the Side Discharge Guard onto the Discharge Deflector.

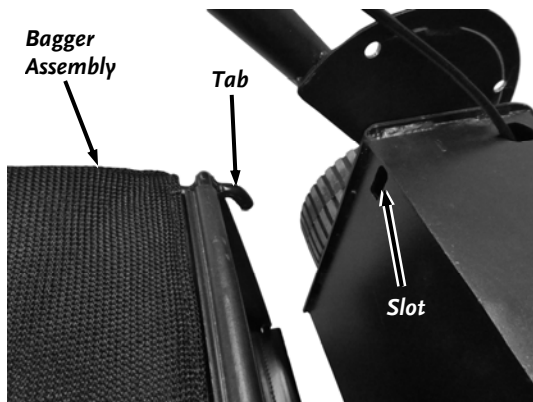

Figure 16

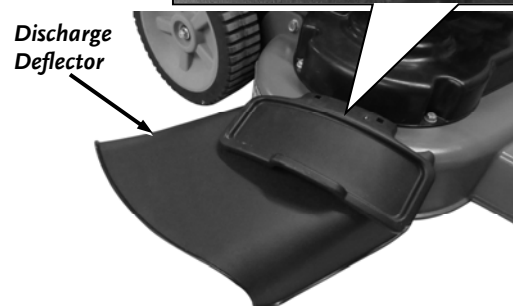
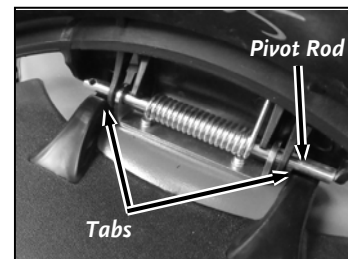

Figure 18



Figure 17

Operating Tips

WARNING

Wet grass or leaves can cause serious injury if you slip and contact the blade. Mow only in dry conditions.

- Clear the area of sticks, stones, wire, branches, and other debris that the blade could hit.
- Avoid striking solid objects with the blade. Never deliberately mow over any object.
- If the mower strikes an object or starts to vibrate, **immediately stop the engine, disconnect the wire from the spark plug**, and examine the mower for damage.
- For best performance, install a new blade before the cutting season begins.
- Replace the blade when necessary with a DR Power Equipment replacement blade.
- For demanding jobs, such as thick wet grass, Side Discharge mode is recommended to reduce clogging.

Cutting Grass

- Allow the engine to fully warm up prior to mowing.
- Do not cut more than a third of the grass blade at a time.
- When cutting grass over 6 inches (15 cm) tall, mow at the highest cutting height setting and walk slower; then mow again at a lower setting for the best lawn appearance. If the grass is too long, the mower may plug and cause the engine to stall.
- Mow only dry grass or leaves. Wet grass and leaves tend to clump on the yard and can cause the mower to plug or the engine to stall.
- Alternate the mowing direction. This helps disperse the clippings over the lawn for even fertilization.
- If the finished lawn appearance is unsatisfactory, try one or more of the following:
 - Replace the blade or have it sharpened.
 - Walk at a slower pace while mowing.
 - Raise the cutting height on your mower.
 - Cut the grass more frequently.
 - Overlap cutting swaths instead of cutting a full swath with each pass.

Cutting Leaves

- After cutting the lawn, ensure that half of the lawn shows through the cut leaf cover. You may need to make more than one pass over the leaves so more of the lawn shows through.
- Slow down your mowing speed if the mower does not cut the leaves finely enough.

Slope Operation

WARNING

Slopes are a major factor related to slip and fall accidents, which can result in severe injury. Operation on all slopes requires extra caution. If you feel uneasy on a slope, do not mow it.

- Do not use the Mower on slopes greater than 20 degrees. Doing so could result in serious injury or damage to your machine.
- Mow across the face of slopes; never up and down. Exercise extreme caution when changing direction on slopes.
- Watch for holes, ruts, bumps, rocks, or other hidden objects. Uneven terrain could cause a slip and fall accident. Tall grass can hide obstacles.
- Do not mow on wet grass or excessively steep slopes. Poor footing could cause a slip and fall accident.
- Do not mow near drop-offs, ditches, or embankments. You could lose your footing or balance.

Chapter 4: Maintaining the DR WIDE-CUT LAWN MOWER

Regular maintenance is the way to ensure the best performance and long life of your machine. Please refer to this manual and the engine manufacturer's owner's manual for maintenance procedures. Service intervals listed in the checklist below supersede those listed in the engine manufacturer's owner's manual.

! WARNING

Before performing any maintenance procedure or inspection on the Mower, release the blade control bail bar to stop the blades. Shut off the engine and wait 5 minutes for parts to cool. Remove the spark plug wire, keeping it away from the spark plug, and disconnect the negative battery wire to prevent accidental starting.

Regular Maintenance Checklist

PROCEDURE	BEFORE EACH USE	EVERY 25 HOURS	EVERY 100 HOURS
Check Engine Oil Level*	▲		
Check General Equipment Condition	▲		
Check Blades for Sharpness	▲		
Remove grass clippings and dirt from under the housing	▲		
Clean Engine Exterior & Cooling Fins	▲		
Check Belt Tension and Condition		▲	
Grease Idler Arm Fitting		▲	
Clean Air Filter		▲	
Replace Air Filter		▲	
Replace Spark Plug			▲

*Add Engine Oil as Needed



Figure 19

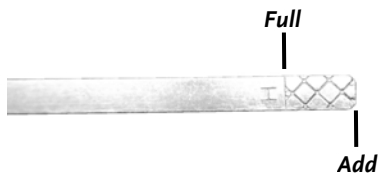

Figure 20

Checking the Engine Oil Level

NOTICE

To get an accurate reading when checking the oil level:

- The machine should be on a level surface.
- Insert the Dipstick into the filler hole with Cap resting on top, but do not screw it down.

1. Remove the Oil/Fill Dipstick, wipe it clean, and insert it back into the Oil Fill but do not screw it down (**Figure 19**).
2. Remove the dipstick and check the oil level (**Figure 20**). If the oil level is below the Operating Range on the dipstick, slowly pour oil into the oil fill tube until the oil level reaches the Operating Range on the dipstick. Do not overfill. (See your Engine users manual for detailed information on Oil type and quantity)
3. Insert and fully screw on the dipstick when the Oil level is correct.

Replacing the Oil

Tools and Supplies needed:

- SAE 30: above 40 degrees F; 10w-30: 10-90 degrees F; 5w-30: 40 degrees F or below (refer to your Engine Owner's Manual for quantity required)
- Small Engine Oil Extractor
- Rags

1. Remove the Oil Cap/Dipstick and position the tube of the Extractor into the Oil Cap/Dipstick hole (**Figure 21**).
2. Remove the Oil as described in the Oil Extractor instructions.
3. Refill the Engine using the recommended oil to the level indicated on the Dipstick.
4. Replace the Oil Cap/Dipstick when finished.

Note: Be sure to use environmentally safe disposal procedures in the disposing of the used oil.

Idler Arm Lubrication

Tools & Supplies Needed:

- Grease Gun w/General Purpose Grease
1. Set the Height Adjustment Lever to the 2nd or 3rd notch from the rear to lower the Deck (**Figure 22**).
 2. Remove the four Bolts securing the Belt Cover (**Figure 23**).
 3. First move the right hand side of the Belt Cover forward and then pull the Belt Cover under the Height Adjust Linkage and out the left side (**Figure 24**).
 4. Locate the Grease Fitting on the idler arm (**Figure 25**).
 5. Using the grease gun add a small amount of grease (1-2 pumps or until slight resistance).

Note: Over greasing may cause grease to leak onto the Mower Drive Belt.

6. Reinstall the Belt Cover in the reverse order.



Figure 21

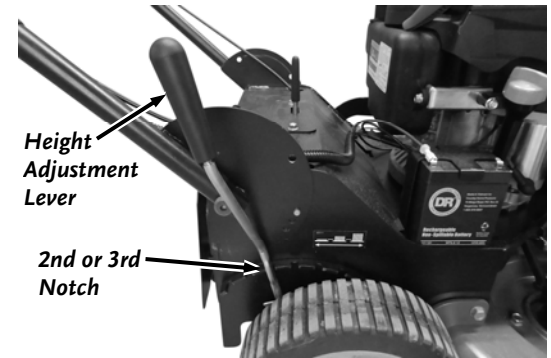

Figure 22



Figure 23

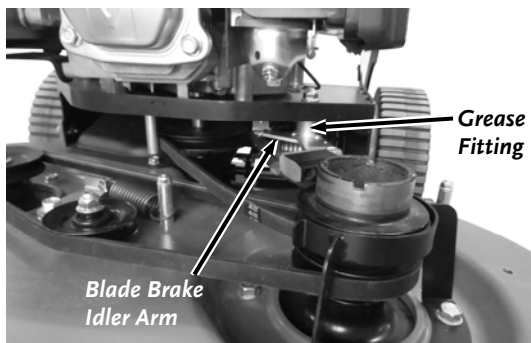

Figure 25

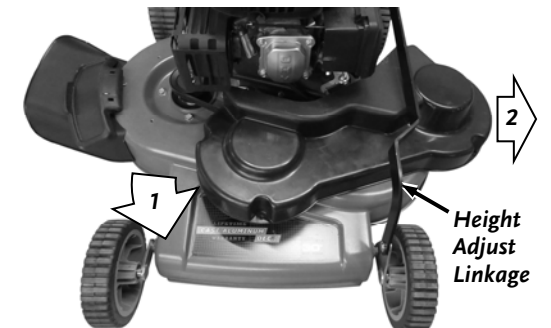

Figure 24

Removing the Blades for Replacement or Sharpening

Tools and Supplies Needed:

- 3/4" Socket
- Ratchet with Extension
- Torque Wrench
- Block of Wood
- Gloves

WARNING

The blade is sharp; contacting the blade can result in serious personal injury. Wear gloves when servicing the blade.

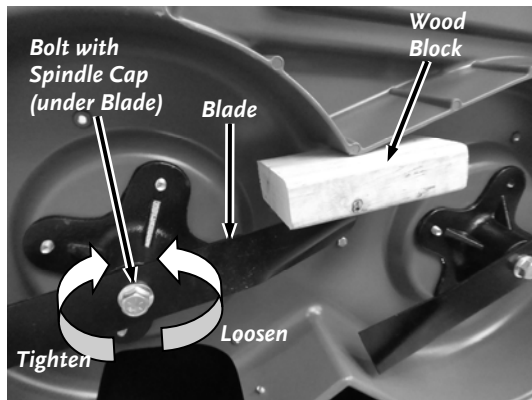

Figure 26

IMPORTANT: You will need a torque wrench to install the blade properly. If you do not have a torque wrench or are uncomfortable performing this procedure, contact us at www.DRpower.com.

Examine the blade whenever you run out of gasoline. If the blade is damaged or cracked, replace it immediately. If the blade edge is dull or nicked, have it sharpened or replace it.

1. Remove the Belt Cover as described in "Idler Arm Lubrication" steps 1 thru 3.
2. Support the Mower with Blocks or a Jack Stand to gain access under the Deck.
3. Use a block of wood between the Blade and Deck to hold the blade from turning (**Figure 26**).
4. Remove Bolt, Blade, and Spindle Cap.

IMPORTANT: Make sure in the following step that you position the curved ends of the blade pointing up toward the mower housing.

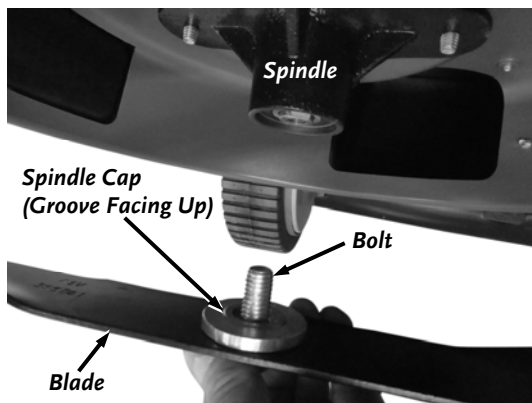

Figure 27

5. Position the Spindle Cap (groove facing up) and Blade (bent ends facing up) onto the Shaft and secure with the Bolt (**Figure 27**).
6. Hold the Pulley Locknut at the top side of the Deck with a 3/4" Socket so the Bolts can be torqued in the next step (**Figure 28**). The Pulley will rotate if the Pulley Bolt is not held while tightening.
7. Secure the Blade Bolt using a torque wrench to tighten the Bolt to 55 ft-lb (74.6 Nm).
8. Reinstall the Belt Cover when finished.

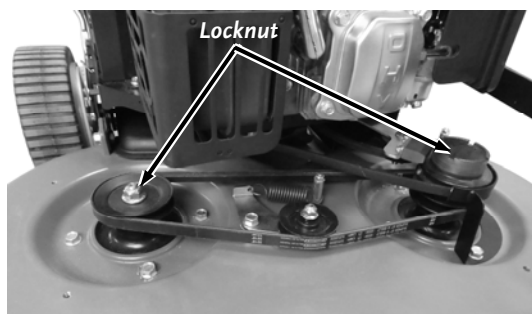

Figure 28

Replacing the Blade Belt

! WARNING

ONLY USE DR BELTS ON THE DR MOWER. The Belts have been tested and are designed specifically to work with the Blade Braking system. Use of other Belts could damage the machine and cause serious injury to the operator.

Tools and Supplies Needed:

- DR Belt #395621 (SP30), # A0000033075 (SP26)
- 1/2" Wrench
- 9/16" Wrench

1. Remove the Belt Cover as described in "Idler Arm Lubrication" steps 1 thru 3.
2. Remove the two Bolts securing the Blade Pulley Belt Guide (**Figure 29**).
3. Remove the Blade Brake Belt from the Blade Pulley by rotating the Pulley with a Screwdriver (in slots) as you roll the Blade Brake Belt over the top of the Pulley (**Figure 30**).
4. Move the Blade Brake Arm back and move the Blade Brake Belt out of the way.
5. Move the Blade Belt Idler back and remove the Blade Belt from the right side Pulley (**Figure 31**).
6. Move the Blade Brake Arm back and remove the Blade Belt from the machine.
7. Install the new Blade Belt.
8. Reinstall the Blade Brake Belt.
9. Reinstall the Belt Guide.
10. Reinstall the Belt Cover.

Replacing the Blade Brake Belt

! WARNING

ONLY USE DR BELTS ON THE DR MOWER. The Belts have been tested and are designed specifically to work with the Blade Braking system. Use of other Belts could damage the machine and cause serious injury to the operator.

Tools and Supplies Needed:

- DR Belt #395651 (SP30), 396151 (SP26)
- 1/2" Wrench
- 9/16" Wrench

1. Remove the Traction Drive Belt as described in the "Replacing the Traction Drive Belt" section on the next page.
2. Remove the Belt Cover as described in "Idler Arm Lubrication" steps 1 thru 3 on page 17.
3. Remove the two Bolts securing the Blade Pulley Belt Guide and remove the Guide (**Figure 32**).

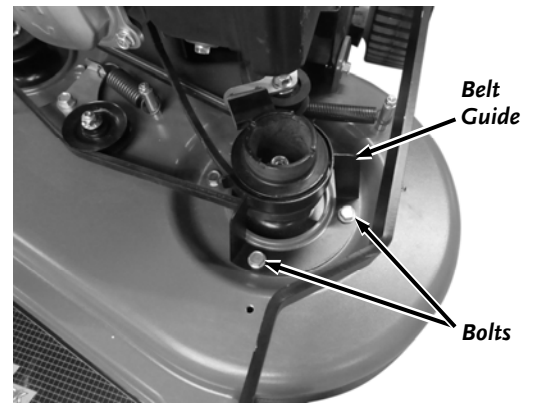

Figure 29

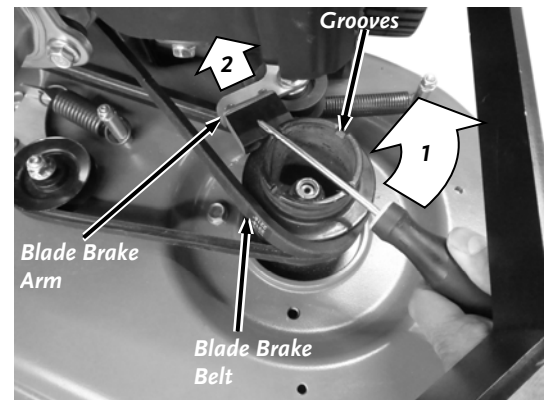

Figure 30

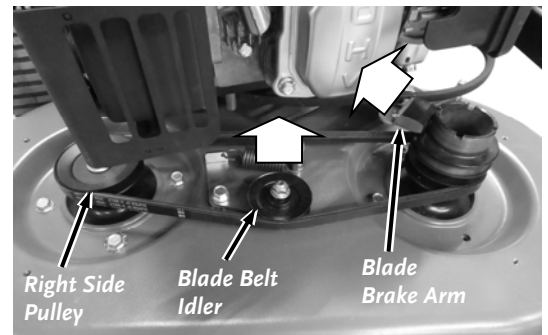

Figure 31

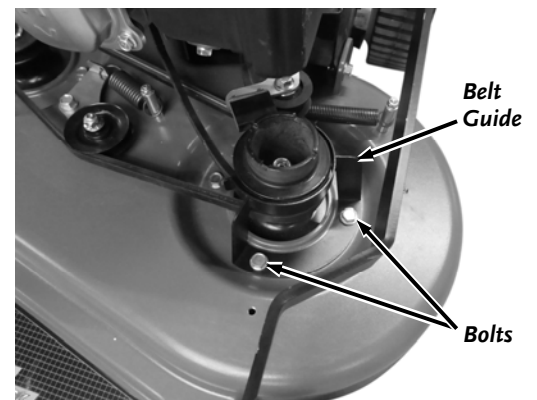

Figure 32

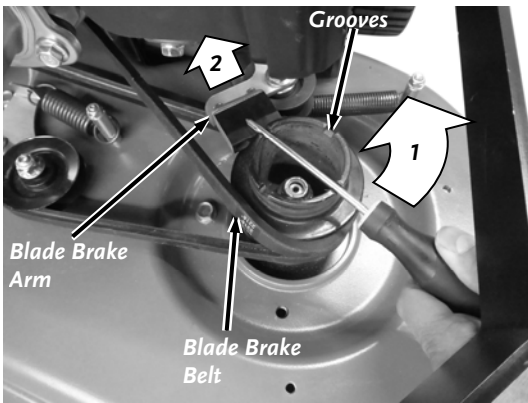

Figure 33

4. Remove the Blade Brake Belt from the Blade Pulley by rotating the Pulley with a Screwdriver (in slots) as you roll the Blade Brake Belt over the top of the Pulley (**Figure 33**).
5. Push the Blade Brake Arm back and remove the Blade Brake Belt from the Blade and Engine Pulleys.
6. Install the new Belt onto the Engine Pulley and Blade Pulley.
7. Reinstall the Belt Guide.
8. Reinstall the Belt Cover.
9. Reinstall the traction Drive Belt.

Replacing the Traction Drive Belt

! WARNING

ONLY USE DR BELTS ON THE DR MOWER. The Belts have been tested and are designed specifically to work with the Blade Braking system. Use of other Belts could damage the machine and cause serious injury to the operator.

Tools and Supplies Needed:

- DR Belt #395651 (SP30), #396151 (SP26)
- 9/16" Wrench
- Locking Pliers

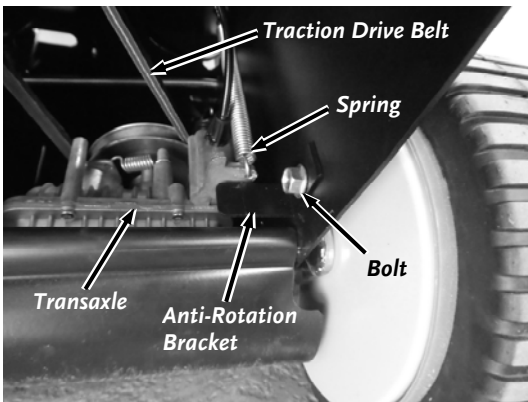

Figure 34

1. Support the front of the Mower with Blocks or Jack Stands to gain access under the Deck.
2. Remove the Bolt securing the Anti-Rotation Bracket and remove the Bracket (**Figure 34**).
3. Remove the Spring end from the Transaxle using Locking Pliers.
4. Rotate the transaxle forward to remove the Belt from the Transaxle pulley and Engine Pulley.
5. Install the new Belt onto the Pulleys.
6. Secure the Spring to the Transaxle using Locking Pliers.
7. Reinstall the Anti-Rotation Bracket.

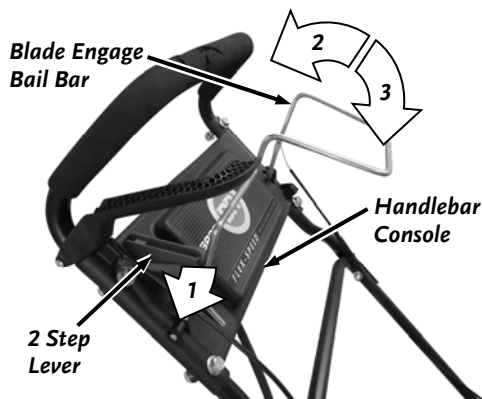

Figure 35

Adjusting the Blade Engage Cable

The Blade Engage Belt will stretch slightly when new, then more over time. If the Belt appears to be slipping when mowing, adjust the Blade Engage Cable to tighten it. The Adjuster is located on the Cable itself. If adjusting the Cable doesn't stop the Belt from slipping, replace the Blade Engage Belt.

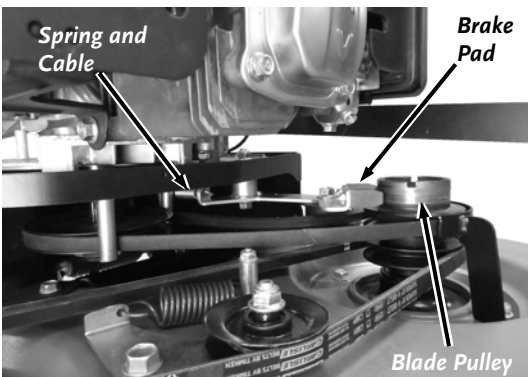

Figure 36

1. Remove the Belt Cover as described in "Idler Arm Lubrication" steps 1 thru 3 on page 17.
2. Engage and release the Blade Engage Bail Bar a few times, then fully release it (**Figure 35**).
3. With the Blade Engage Bail Bar released, ensure that the Brake Pad is resting against the Blade Pulley and the Cable going from the Console to the Bail Bar has a small amount of play (is slightly loose). (**Figure 36**).

4. Double Check that the Belt wraps tightly around the Pulleys when Bail Bar is engaged and that the Brake fully engages the Pulley when the Bail Bar is released (**Figure 33**). Tighten/loosen the Cable as needed by the following steps.
5. Locate the Blade Engage Cable along the left Handlebar. There is an In-Line Adjuster to change the tension on the Cable (**Figure 37**).
6. You can tighten the cable by rotating the body of the In-Line Adjuster in the clockwise direction (looking down on the Cable). If the Cable is too tight, you can loosen the Cable by twisting the adjuster in the opposite direction.

Note: The Blade Engage Cable is adjusted properly when the coils of the Spring are pulled apart slightly when the Bail Bar is pulled fully against the Handlebar. When the Bail Bar is released, there should be a very slight sag in the Spring and Cable.

Adjusting the Traction Drive Cable

If the Traction Drive appears to be losing speed, the Traction Drive Cable must be tightened to restore maximum speed. Avoid over tensioning the Cable because it may cause the Transmission to engage even if the Drive Lever is fully released.

If the Mower is difficult to push forward when the Traction Drive Lever is fully released, the Cable tension will need to be loosened to disengage the Transmission.

Note: When properly adjusted, tension on the Traction Drive Lever should increase when the Lever is about parallel to (almost touching) the Handlebar Grip.

1. Locate the Traction Drive Cable on the Handlebar (**Figure 38**). There is an In-Line Adjuster to change the length of the Cable.
2. Rotate the center portion clockwise while holding the ends stationary to expand the In-Line Adjuster and remove slack from the cable as needed. Counterclockwise rotation will add more slack in the Cable.

Replacing the Battery

Tools and Supplies Needed:

- 3/8" Wrench

REMOVAL

1. Remove the Battery Wires from the Terminals (**Figure 39**).
2. Remove the Bolt that secures the Battery Bracket.

Note: There are wire terminals secured by the Battery Clamp Bolt. These wires must be secured by the bolt when the Battery Clamp is reinstalled.

3. Position the Battery and install the Battery Clamp.
4. Install the wires onto the Bolt and install the Bolt to secure the Clamp.
5. Reinstall the Battery Wires.

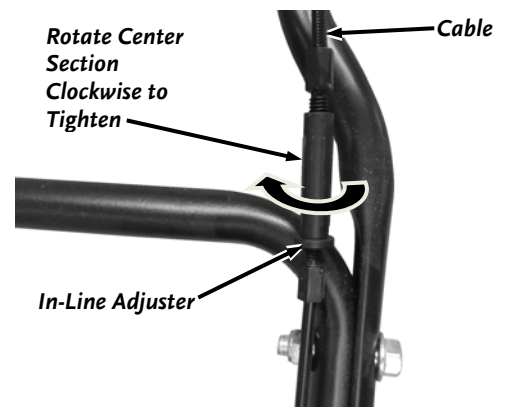

Figure 37

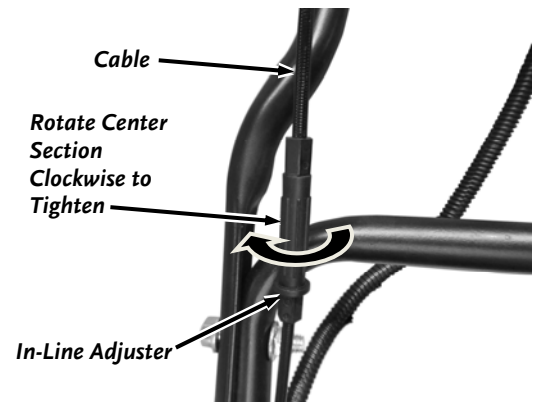

Figure 38

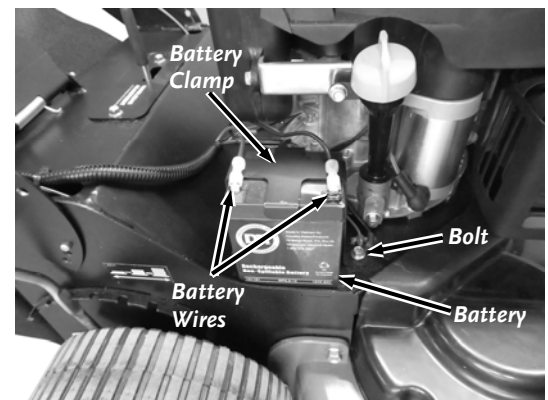

Figure 39

Battery Care (For Electric-Starting Models Only)

Proper care can extend the life of a Battery. Follow these recommendations to ensure your Battery's best performance and long life:

- Do not allow the Battery charge to get too low. If the machine is not used, charge the Battery every 4 – 6 weeks. Operate the engine for at least 45 minutes to maintain proper Battery charge.
- Store an unused Battery in a dry area that does not freeze.
- Do not charge an already charged Battery. In theory, you cannot overcharge our Battery with a trickle charger; however, when a Battery is fully charged and the charger is still on, it generates heat that could be harmful to the Battery. A fully charged Battery will read 12V-13.2V with a voltmeter.
- Do not continue to crank your Engine when the Battery charge is low.

Charging the Battery

⚠ WARNING

Before performing any maintenance procedure or inspection on the Mower, release the blade control bail bar to stop the blades. Shut off the engine and wait 5 minutes for parts to cool. Remove the spark plug wire, keeping it away from the spark plug and disconnect the negative battery wire to prevent accidental starting.

NOTICE

When you are finished charging the battery, disconnect the charger from the outlet first, then disconnect the battery charger wires from the battery. If you leave the battery charger wires connected to the battery, the battery will discharge itself back into the charger.

Operate the mower Engine for at least 45 minutes to maintain proper Battery charge. If the Battery loses its charge, you will need to use a trickle charger (like the DR Battery Charger) to recharge it. The Charger should have an output of 12 volts at no more than 2 amps.

- At 1 amp the Battery may need to be charged for as long as 48 hours.
- At 2 amps, the Battery may need to be charged for as long as 24 hours.

Note: *Using the Recoil Starter and then running the Engine will not recharge a dead or significantly discharged Battery.*

To connect a Battery Charger to your DR WIDE-CUT LAWN MOWER, follow the steps listed below.

1. Remove the upper Belt Cover and pull the protective rubber material from the terminals.

Note: *An alternative method could be to remove the Cover at the back of the machine and remove the Battery from the Bracket to charge it.*

2. Attach the Black (-) alligator clipped wire from the Charger Adapter to the Negative (-) terminal of the Battery, then attach the Red (+) alligator clipped wire to the Positive (+) Battery terminal.
3. Plug the Charger into a standard wall outlet.
 - Typically, the Battery takes between 6 and 8 hours to fully charge. The Battery does not have a "memory"; so don't worry about overcharging the Battery or charging it too often.
 - You can charge the Battery many times. The Battery lasts longer if you charge it before it is fully drained. Keep it fully charged and at room temperature when not using your mower.
 - If the Battery does not hold its charge for very long under normal conditions or it simply won't hold a charge, then replace it. You can purchase replacement Batteries directly from us. To install your new Battery, follow the directions on the previous page.

Chapter 5: Troubleshooting

Most problems are easy to fix. Consult the Troubleshooting Table below for common problems and their solutions. If you continue to experience problems, contact us at www.DRpower.com or call toll-free 1-800-DR-OWNER (376-9637) for support.

WARNING

Before performing any maintenance procedure or inspection on the Mower, release the blade control bail bar to stop the blades. Shut off the engine and wait 5 minutes for parts to cool. Remove the spark plug wire, keeping it away from the spark plug and disconnect the negative battery wire to prevent accidental starting.

Troubleshooting Table

SYMPTOM	POSSIBLE CAUSE
<i>Recoil will not pull out or is difficult to pull.</i>	<ul style="list-style-type: none"> ⇒ The engine is difficult to start in heavy or high grass. Move the mower to a clean dry surface. ⇒ Make sure the blade control Bail Bar is NOT in operating position. ⇒ Check the Engine oil level, the Engine may be seized. ⇒ There may be an oil compression lock in the Cylinder. Take out the Spark Plug; hold a rag over the Spark Plug hole and pull the Recoil Cord several times to blow out any oil in the Cylinder. Wipe off the Spark Plug and reinstall it. ⇒ The Recoil may be broken or jammed. Visit our web site at www.DRPower.com or call 1-800-DR-OWNER (376-9637) for assistance.
<i>The Engine will not start manually (Please refer to the Engine Owner's Manual for Engine-specific procedures.)</i>	<ul style="list-style-type: none"> ⇒ Ensure the Key Switch is in the RUN position. ⇒ Make sure the blade control Bail Bar is NOT in operating position. ⇒ Check for proper attachment of the Spark Plug wire. ⇒ Check that the Engine has the right amount of oil. ⇒ You should be using fresh, clean, unleaded gas. If the gas is old, change it. Use a fuel stabilizer if you keep gas longer than one month. ⇒ Check that the Air Filter is clean. If it is dirty, change it following the procedure in the Engine Owner's Manual. ⇒ Make sure that the Spark Plug is clean. If the Spark Plug is dirty or cracked, change it. If it's oily, leave it out, hold a rag over the Spark Plug hole and pull the Recoil Cord several times to blow out any oil in the Cylinder, then wipe off the Spark Plug and reinsert it. ⇒ If the Engine still will not start, visit our web site at www.DRPower.com or call 1-800-DR-OWNER (376-9637) for assistance.
<i>The Engine will not start using Electric-Start. (Please refer to the Engine Owner's Manual for engine-specific procedures.)</i>	<ul style="list-style-type: none"> ⇒ Check the previous section (Manual Starting) for possible causes. ⇒ Check the wire connections—especially the ground wire connection to the Battery Bracket. ⇒ The Battery should be charged. Check the voltage yourself or at a gas station. If it's low, charge it with a 12-volt, 1 to 2 Amp trickle charger. If you don't use your machine for at least 45 minutes at a time, the Battery may need to be periodically charged. See the Battery Care section in Chapter 4. ⇒ If your Battery is charged and your mower still won't start, visit us at www.DRpower.com or call 1-800-DR-OWNER (376-9637) for assistance.

Troubleshooting Table (continued)

SYMPTOM	POSSIBLE CAUSE
<i>The Engine will not stop.</i>	<ul style="list-style-type: none"> ⇒ Release the blade control Bar. If the engine does not stop when the blade control Bar is released, pull the spark plug wire off the spark plug using insulated handle pliers and call us at 1-800-DR-OWNER (376-9637) for assistance. ⇒ Make sure that the Wire harness did not disconnect from the key switch. Reconnect if it has.
<i>Engine smokes.</i>	<ul style="list-style-type: none"> ⇒ Check the oil level and adjust as needed. ⇒ You may be operating the machine on too great an incline. ⇒ Check the Air Filter and clean or replace as needed. ⇒ You may be using the wrong oil - too light for the temperature. Refer to your Engine Owner's Manual for detailed information. ⇒ Clean the Engine cooling fins and the carburetor housing if they are dirty. ⇒ If the Engine still smokes, visit our web site at www.DRPower.com or call 1-800-DR-OWNER (376-9637) for assistance.
<p><i>The Engine lacks power or is not running smoothly.</i></p> <p><i>(Please refer to the Engine Owner's Manual for Engine-specific procedures.)</i></p>	<ul style="list-style-type: none"> ⇒ Check the height of cut settings. Raise the height of cut if the grass is high. ⇒ Allow the engine to fully warm up if it is cold. The Auto Choke feature requires a cold engine to heat to operating temperature prior to achieving full operating RPM. ⇒ Check the bottom of the mower housing. Clean the blade housing of grass and other debris. ⇒ Check for debris (hay seed, etc.) clogging the Air Filter Intake and clean out as required. ⇒ The Engine's Blower Housing, Throttle Linkage, and Cooling Fins should be free of debris. Clean them following the instructions in the Engine Owner's Manual. ⇒ Check that the Air Filter is clean. If it is dirty, change it following the procedure in the Engine Owner's Manual. ⇒ Remove the Spark Plug wire and dry the connection with a rag. ⇒ The Spark Plug may be dirty or cracked, change it. If it's oily, leave it out, hold a rag over the Spark Plug hole and pull the Recoil Cord several times to blow out any oil in the Cylinder, then wipe off the Spark Plug and reinsert it. ⇒ You should be using fresh, clean, unleaded gas. If it is old, change it. Use a fuel stabilizer if you keep gas longer than one month. ⇒ Check that the Engine has the right amount of oil. ⇒ If your Engine still lacks power, visit our web site at www.DRPower.com or call 1-800-DR-OWNER (376-9637) for assistance.
<i>Excessive Vibration</i>	<ul style="list-style-type: none"> ⇒ Remove the blades and check for balance. Repair or replace as needed. ⇒ Check for a bent or broken blade. A DAMAGED BLADE IS DANGEROUS AND MUST BE REPLACED. ⇒ Check the blade adapter. Replace a broken blade adapter. ⇒ If the vibration continues, visit our web site at www.DRPower.com or call 1-800-DR-OWNER (376-9637) for assistance.
<i>The grass will not discharge correctly.</i>	<ul style="list-style-type: none"> ⇒ Clean the bottom of the mower housing. ⇒ Check for a badly worn blade. Remove and sharpen the blade. For safety, replace the blade every two years with a DR Power replacement blade. ⇒ Check bagger assembly. Clean and dry bagger assembly as needed. ⇒ The engine speed is too slow. Place throttle control in FAST position.

SYMPTOM	POSSIBLE CAUSE
<i>The grass is not cut even.</i>	⇒ Check the blades for sharpness. Sharpen the blades as needed. ⇒ Check for a bent or broken blade. A DAMAGED BLADE IS DANGEROUS AND MUST BE REPLACED. ⇒ Check the blade adapter. Replace a broken blade adapter. ⇒ Check bagger assembly. Clean and dry bagger assembly as needed.
<i>Traction Drive Lacks Power.</i>	⇒ Improper cable adjustment. Tighten cable to increase power. ⇒ Anti rotation bracket is not installed or not installed properly. Check that it is installed correctly.

Chapter 6: Parts Lists and Schematic Diagrams

Parts List – Deck Assembly

Note: Part numbers listed are available through DR Power Equipment.

Ref#	Part#	Description	Ref#	Part#	Description
1	362801	Spindle Assembly, Finish	20	144091	Pulley, V-Belt, 2-5/8"
2	395701	Blade, 15.13", High Lift (SP 30)	21	395611	Chute, Discharge
	396291	Blade, 13.13", High Lift (SP26)	22	396281	Plug, Mulching
3	395561	Pulley, 3.5" OD, 3/4" Hub, A Profile	23	379151	Bushing, Belt Guide
4	395521	Bushing, Idler, Blade Belt	24	352811	Bolt, Hex Flange, TL, 3/8-16 X 3/4"
5	395511	Arm, Idler, Blade Belt	25	289901	Screw, Unsltd Trilobe, 3/8-16 X 1"
6	396141	Cover, Belt, 30" Deck	26	111731	Screw, 5/16-18 X 1/2", Tri
	396271	Cover, Belt, 26" Deck	27	101451	Bolt, HSC, 1/4-20 X 1-1/2", GR5, ZP
7	A0000043848	Spring, Ext, 1" OD X 3"L X 0.105 Wire	28	114561	Bolt, HCS, 1/4-20 X 2", GR5, ZP
8	10000047518	Guide, Belt, Sheet metal, Blade Pulley, 3.5" (SP30)	29	119851	Bolt, HCS, 3/8-16 X 1 1/2", GR5, ZP
	396171	Guide, Belt, Sheet metal, Blade Pulley, 3" (SP26)	30	333331	Nut, Nylon Lock, Flanged, 3/8-16
9	10000040695	Pulley, Blade Brake, 3.5" (SP30)	31	333351	Nut, Nylon Lock, Flanged, 1/2-13
	395401	Pulley, Blade Brake, 3" (SP26)	32	333311	Nut, Nylon Lock, Flanged, 1/4-20
10	395341	Wheel, Front, 8" X 2", Square Tread	33	365631	Bolt, Hex Flange, 1/2-13 X 1.25", GR8, ZP
11	395361	Axle, Front	34	A0000191692	Label, Deck (SP30)
12	395391	Bushing, Axle		A0000191694	Label, Deck (SP26)
13	10000040701	Guard, Side Discharge (SP30)	35	362791	Cap, Spindle, Finish
	10000041070	Guard, Side Discharge (SP26)	36	371691	Key, ANSI #605 Woodruff, 3/16" X 5/8"
14	10000041169	Spring, Torsion, Discharge Guard	37	136491	Label, Danger
15	10000040677	Bracket, Discharge Cover	38	A0000277001	Guard, Rear Deck, 30", Right
16	A0000296273	Deck, Cast w/labels (SP30)		A0000277004	Guard, Rear Deck, 26", Right
	A0000296272	Deck, Cast w/labels (SP26)		A0000276999	Guard, Rear Deck, 30", Left
17	395621	Belt, A40, Wrapped (SP30)		A0000277003	Guard, Rear Deck, 26", Left
	A0000033075	Belt, A36, Wrapped (SP26)	Not Shown:		
18	10000040960	Rod, Pivot, -Side Discharge Guard		A0000247447	Label, Warning, Only Replace with DR Belts
19	10000040720	Deflector, Discharge (SP30)			
	10000041115	Deflector, Discharge (SP26)			

Schematic – Deck Assembly

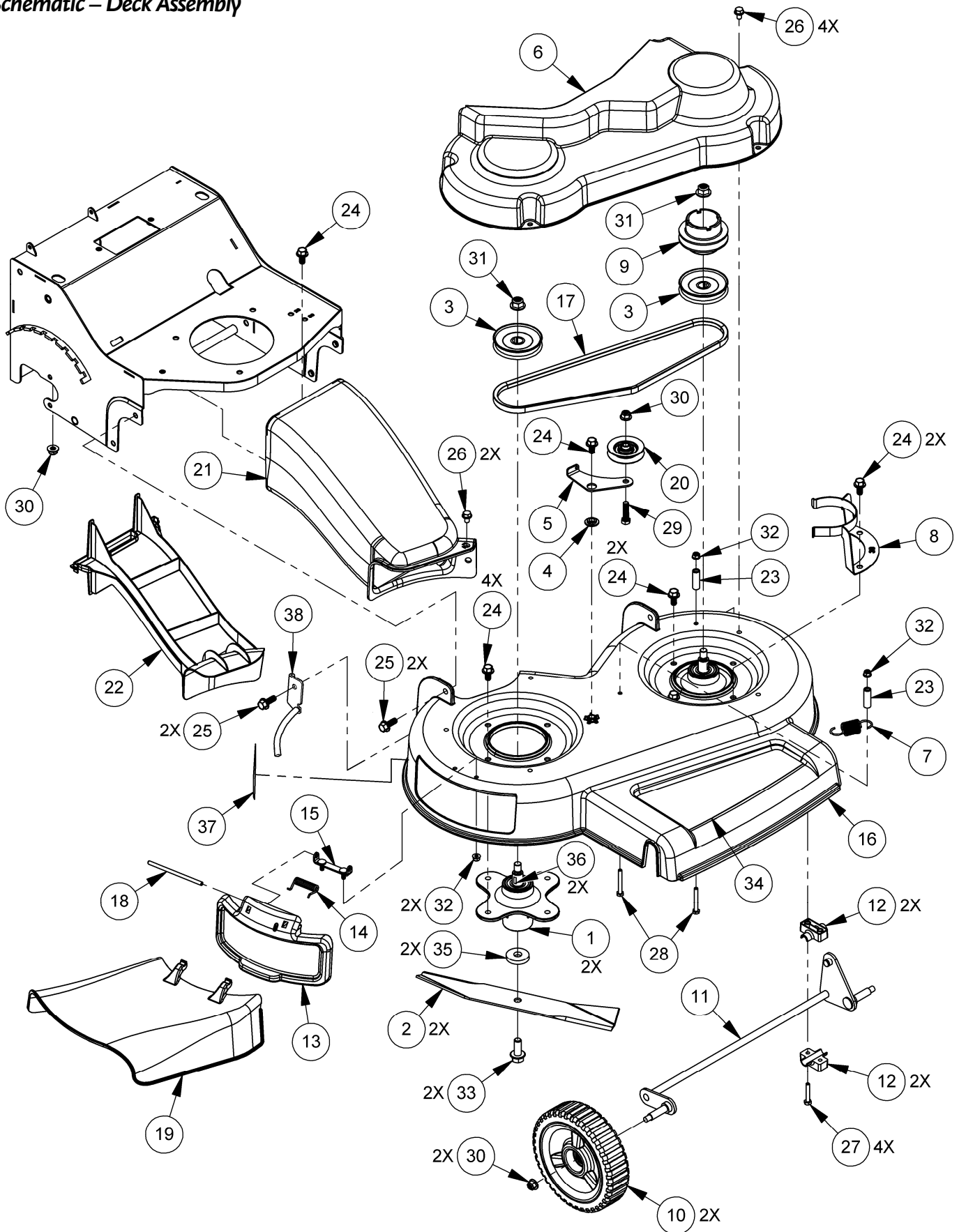

Parts List - Drive Assembly

Note: Part numbers listed are available through DR Power Equipment.

Ref#	Part#	Description	Ref#	Part#	Description
1	10000041169	Spring, Torsion, Discharge Guard	29	395441	Axle, Rear
2	A0000210405	Spring, Extension, Blade Brake	30	395551	Handle, Height Adjust
3	395531	Bushing, Idler, Blade Brake	31	396181	Knob, Tapered, Plastic
4	395541	Arm, Idler, Blade Brake (SP30)	32	395431	Cover, Wheel
	A0000166771	Arm, Idler, Blade Brake (SP26)	33	A0000296268	Linkage, Height Adjust w/labels (SP30)
5	395571	Pulley, Engine		A0000296269	Linkage, Height Adjust w/labels (SP26)
6	A0000296259	Frame	34	352811	Bolt, Hex, Flange, TL, 3/8-16 X 3/4"
7	A0000296276	Engine, DR, 225cc, ES w/labels (SP30)	35	289901	Screw, Unsltd Trilobe, 3/8-16 X 1"
	A0000296277	Engine, DR, 225cc, MS w/labels (SP30)	36	111731	Screw-5/16-18 X 1/2 Tri
	A0000296278	Engine, DR, 200cc, ES w/labels (SP26)	37	365211	Bolt, Hex Flange, 1/4-20 X 5/8", ZP
	A0000296281	Engine, DR, 200cc, MS w/labels (SP26)	38	385961	Bolt, Hex, Flange, 3/8-16 X 1-3/4", GR5
8	395661	Pin, Pivot, Rear Discharge Guard	39	390861	Bolt, Hex, Flange, 3/8-16 X 2-1/4", GR8
9	395771	Guard, Trailing	40	333331	Nut, Nylon Lock, Flanged, 3/8-16
10	A0000296270	Guard, Rear Flap w/labels	41	189751	Ring, Retaining, .468" ID, External
11	396311	Spring, Ext, 1.25" OD, 6.5" L, .162" Wire	42	333311	Nut, Nylon Lock, Flanged, 1/4-20
12	10000040710	Bracket, Anti Rotation, Transmission	43	118731	Nut, Nylon Lock, 10-24
13	A0000215154	Guide-Belt-Pin-Engine Pulley	44	111551	Bolt, HCS, 3/8-24 X 3/4", GR5, ZP
14	131191	Battery, 5.6 Ah, 12V (ES Only)	45	A0000162518	Screw, Plastic Thread Forming, 8-16 X 1"
15	325141	Pad, Secondary Brake, Beaver Blade	46	A0000213836	Label, Warning, General
16	350471	Pulley, Flat Idler, 1.75" X .75"	47	A0000212734	Label, One Touch Height Adjustment
17	A0000020863	Clamp, Battery, 5Ah (ES Only)	48	101891	Zerk, Grease, 1/4-28, Straight
18	377381	Bushing, Spacer	49	0K0982	Ring, Snap, 1/2", Type E
19	395651	Belt, AP35, Blade Brake (SP30)	50	323441	Screw, 10-24 X 0.75", Fillister
	396151	Belt, AP31, Blade Brake (SP26)	51	276761	Pin, Cotter, 3/32" X 1/2", ZP
20	395241	Belt, 3L320, Self Propel	52	A0000191699	Label, Engine Branding, RV225 (SP30)
21	395351	Wheel, Rear, 10" X 3", Square Tread		A0000191697	Label, Engine, RV200 (SP26)
22	395471	Pinion, Rear Axle	53	A0000191696	Label, Engine Torque, RV225 (SP30)
23	395481	Gear, Spur, Drive	54	343251	Bolt, Hex, Flange, 1/4-20 X 1"
24	395461	Housing, Bearing, Rear Axle			
25	391261	Transmission & Axle			
26	396191	Bearing, Flanged, 1/2" ID, 1-3/8" OD			
27	395501	Plate, Support, Bearing			
28	396321	Spring, Ext, 0.5" OD, 5.25" L, 0.08" Wire			
			Not Shown:		
				137581	Label, Warning, Check Oil

Schematic – Drive Assembly

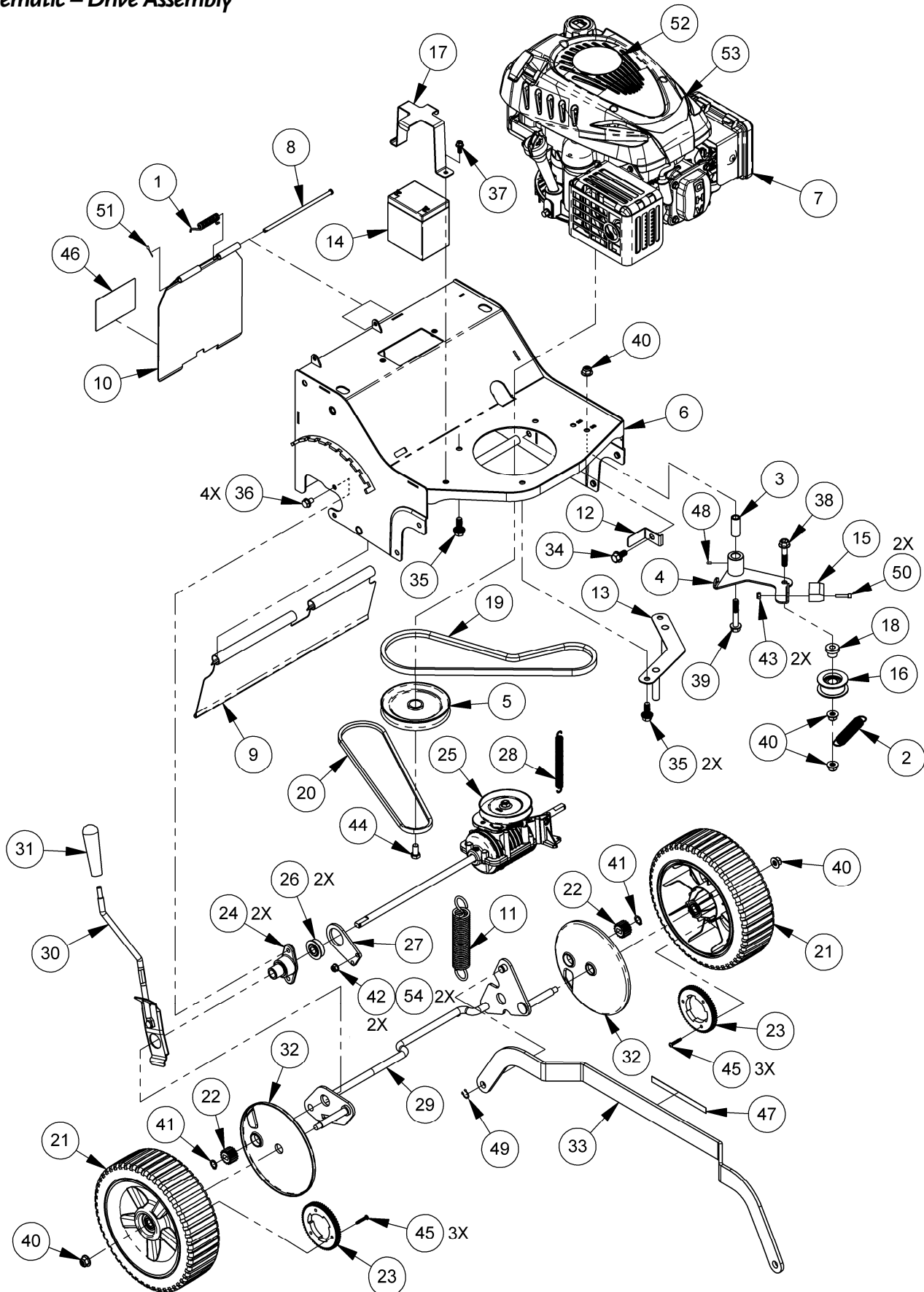

Parts List - Handlebar Assembly

Note: Part numbers listed are available through DR Power Equipment.

<u>Ref#</u>	<u>Part#</u>	<u>Description</u>	<u>Ref#</u>	<u>Part#</u>	<u>Description</u>
1	395601	Lever, Handlebar Adjust	19	333331	Nut, Nylon Lock, Flanged, 3/8-16
2	A0000296271	Bracket, Handlebar Adjust w/labels	20	333311	Nut, Nylon Lock, Flanged, 1/4-20
3	395591	Pin, Wire Form, Handlebar Adjust	21	A0000052226	Bolt, Shoulder, 1/2" OD X 1-1/4" X 3/8-16 Thread
4	10000041178	Spring, Torsion, Handlebar Adjust	22	A0000052276	Pin, Clevis, 1/4" X 2-1/8" ZP
5	395691	Handlebar, Lower	23	A0000203118	Label, Handle Adjust
6	395681	Handlebar, Upper	24	A0000162520	Screw, Plastic Thread Forming, 8-16 X 1/2"
7	395751	Bracket, Switch	25	A0000069640	Wire Harness, E/S
8	395781	Cable, Traction Drive		A0000069641	Wire Harness, M/S
9	395791	Cable, Blade Engage	26	276751	Pin, Clevis, 1/4" X 1-1/8"
10	A0000296274	Console, Handlebar w/labels (SP26)	27	A0000163050	Spring, Torsion, 2-Step Lever
	A0000296275	Console, Handlebar w/labels (SP30)	28	276761	Pin, Cotter, 3/32" X 1/2"
11	151311	Plug, Panel, 2.0" X 1.4"	29	A0000191688	Label, Console (SP30)
12	222231	Switch, Snap in, E/S		A0000191690	Label, Console (SP26)
	165201	Switch, Snap in, M/S	Not Shown:		
13	396221	Bail Bar, Blade Engage		396231	Frame, Grass Bag
14	395721	Lever, Self Propel Drive		396241	Bag, Fabric
15	395741	Lever, 2 Step			
16	365211	Bolt, Hex Flange, 1/4-20 X 5/8", ZP			
17	385961	Bolt, Hex Flange, 3/8-16 X 1-3/4", GR5			
18	343251	Bolt, Hex, Flange, 1/4-20 X 1"			

Schematic – Handlebar Assembly

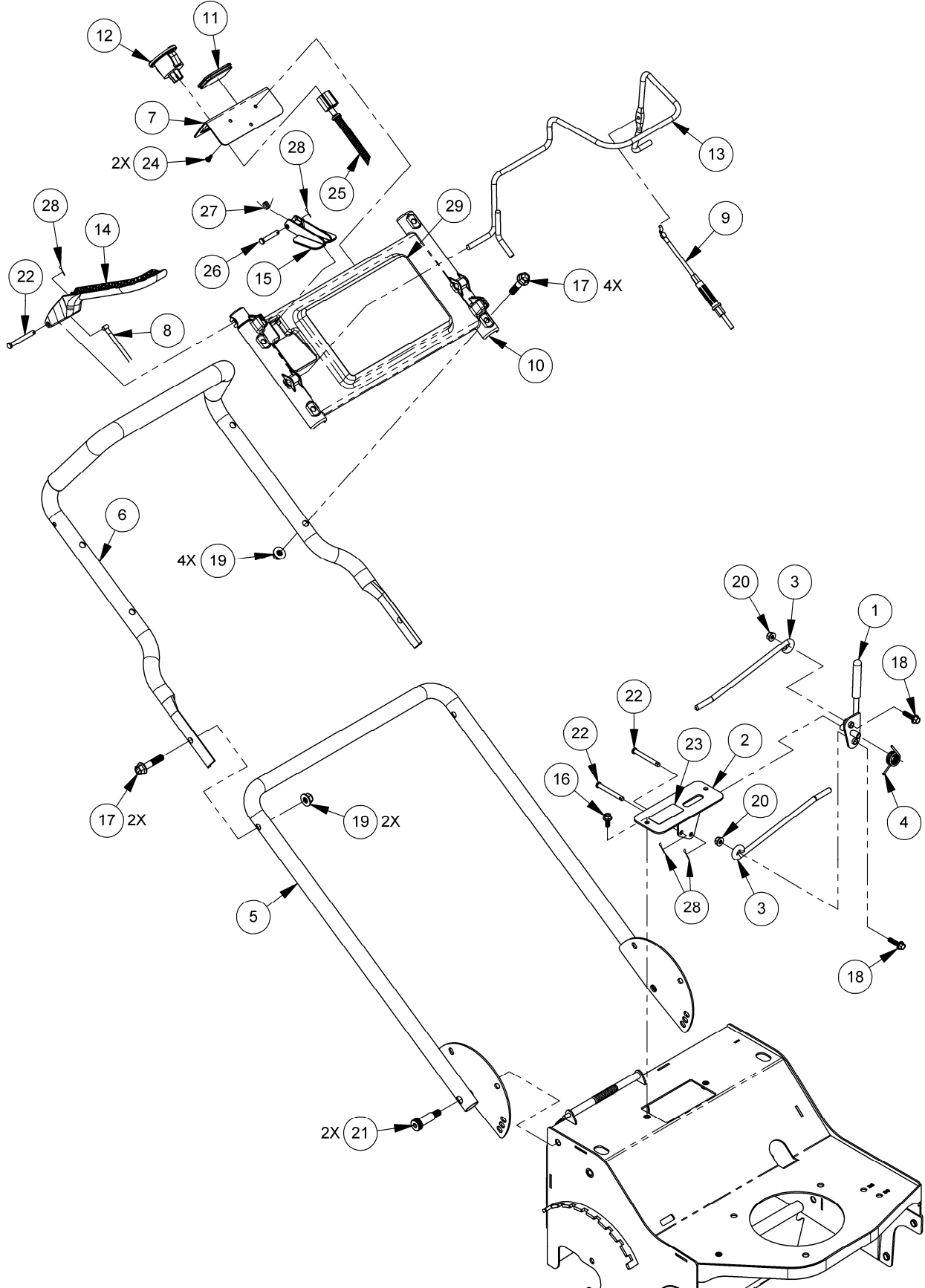

Daily Checklist for the DR WIDE-CUT LAWN MOWER

WARNING

Before performing any maintenance procedure or inspection on the Mower, release the blade control bail bar to stop the blades. Shut off the engine and wait 5 minutes for parts to cool. Remove the spark plug wire, keeping it away from the spark plug and disconnect the negative battery wire to prevent accidental starting.

To help maintain your DR WIDE-CUT LAWN MOWER for optimum performance, we recommend you follow this checklist each time you use your Mower.

- Check the engine oil level.
- Check the fuel level.
- Check that the blades and mounting hardware are not worn or damaged.
- Check the general condition of the Mower, e.g.; nuts, bolts, welds, etc.

Cleaning the Mower

1. For best results, clean the mower soon after you have completed mowing.
2. With the engine running on a flat paved surface, spray a stream of water in front of the right rear wheel.
3. The water will splash into the path of the blade, cleaning out the clippings.
4. When no more clippings come out, stop the water and move the mower to a dry area.
5. Run the engine for a few minutes to dry the housing.

End of Season and Storage

WARNING

Before performing any maintenance procedure or inspection on the Mower, release the blade control bail bar to stop the blades. Shut off the engine and wait 5 minutes for parts to cool. Remove the spark plug wire, keeping it away from the spark plug and disconnect the negative battery wire to prevent accidental starting.

Immediately prepare your mower for storage at the end of the season or if the mower will not to be used for 30 days or more. See your Engine owner's manual for detailed engine care and storage procedures.

- When the mower is to be stored, remove all dirt, grease, leaves, etc.
- On the last refueling of the year, add fuel stabilizer to the fuel as directed by the engine manufacturer. Run the mower until the engine stops from running out of fuel. Prime the engine and start it again. Allow the engine to run until stops. When you can no longer start the engine, it is sufficiently dry. Remove the spark plug, add 1 oz. (30 ml) of oil through the spark plug hole, and pull the starter rope slowly several times to distribute oil throughout the cylinder to prevent cylinder corrosion during the off- season.
- Clean the exterior of the unit to remove all dirt, grease, and any other foreign material. To prevent rust, touch up painted surfaces that have been scratched or chipped.
- Store your mower indoors and cover it with a suitable protective cover to give protection from dust and dirt. Do not use plastic. Plastic cannot breathe which allows condensation to form and will cause some mower parts to rust.



800 HINESBURG ROAD, SOUTH BURLINGTON, VERMONT 05403