

# TOW-BEHIND DR<sup>®</sup> FIELD and BRUSH MOWER

## SAFETY & OPERATING INSTRUCTIONS

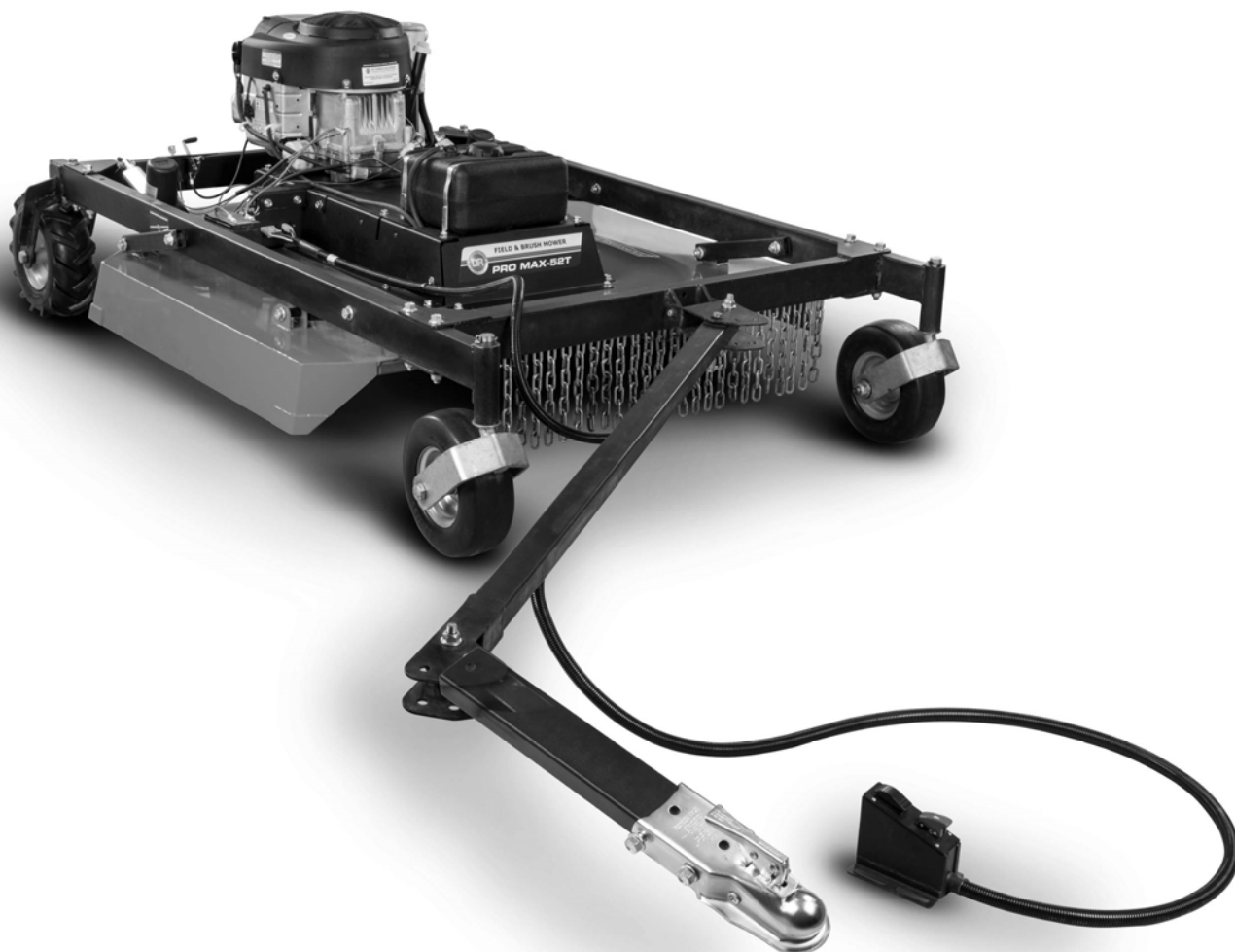

Serial No. \_\_\_\_\_

Order No. \_\_\_\_\_

DR Power Equipment  
Toll-free phone: 1-800-DR-OWNER (376-9637)  
Fax: 1-802-877-1213  
Website: [www.DRpower.com](http://www.DRpower.com)

### **WARNING**

Read and understand this manual and all instructions before operating the TOW BEHIND DR FIELD and BRUSH MOWER.

## Table of Contents

|  |    |
|--|----|
| Chapter 1: General Safety Rules.....                                 | 3  |
| Chapter 2: Setting Up The TOW-BEHIND DR FIELD and BRUSH MOWER.....   | 6  |
| Chapter 3: Operating the TOW-BEHIND DR FIELD and BRUSH MOWER.....    | 14 |
| Chapter 4: Maintaining the TOW-BEHIND DR FIELD and BRUSH MOWER ..... | 20 |
| Chapter 5: Troubleshooting .....                                     | 26 |
| Chapter 6: Parts Lists and Schematic Diagrams.....                   | 28 |

## Conventions used in this manual

### **⚠ WARNING**

This indicates a hazardous situation, which, if not avoided, **could** result in death or serious injury.

### **⚠ CAUTION**

This indicates a hazardous situation, which, if not avoided, **could** result in minor or moderate injury.

### **NOTICE**

This information is important in the proper use of your machine. Failure to follow this instruction could result in damage to your machine or property.

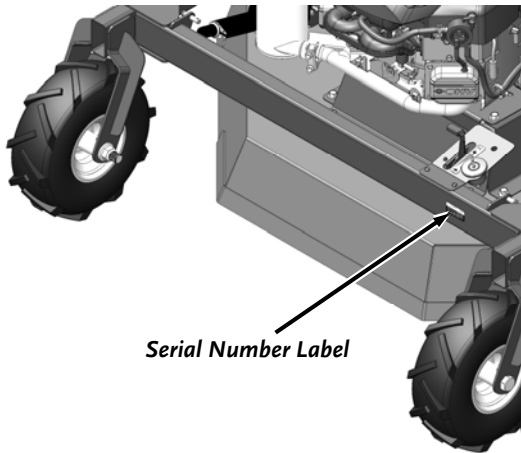

Figure 1

### **Serial Number and Order Number**

A Serial Number is used to identify your machine and is located on the Serial Number Label on your machine (**Figure 1**). An Order Number is used to check and maintain your order history and is located on your packing slip. For your convenience and ready reference, enter the Serial Number and Order Number in the space provided on the front cover of this manual.

### **Additional Information and Potential Changes**

DR Power Equipment reserves the right to discontinue, change, and improve its products at any time without notice or obligation to the purchaser. The descriptions and specifications contained in this manual were in effect at printing. Equipment described within this manual may be optional. Some illustrations may not be applicable to your machine.

## Chapter 1: General Safety Rules

### **WARNING**

Read this Safety & Operating Instructions manual before you use the TOW BEHIND DR FIELD and BRUSH MOWER. Become familiar with the operation and service recommendations to ensure the best performance from your machine. If you have any questions or need assistance, please contact us at [www.DRpower.com](http://www.DRpower.com) or call toll-free 1-800-DR-OWNER (376-9637) and one of our Technical Support Representatives will be happy to help you.

### Labels

Your TOW BEHIND DR FIELD and BRUSH MOWER carries prominent labels as reminders for its proper and safe use. Shown below are copies of all the Safety and Information labels that appear on the equipment. Take a moment to study them and make a note of their location on your Mower as you set up and before you operate the unit. Replace damaged or missing safety and information labels immediately.



#13649



#13683



#13758



#36581



#36582

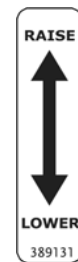

#38913



#36585



#37122



#36584

## Protecting Yourself and Those around You

---

### **WARNING**

This is a high-powered machine with moving parts operating at high speeds. Always take the following precautions when operating this machine:

- Always wear protective goggles or safety glasses with side shields.
  - We recommend wearing sturdy shoes with non-slip tread, long pants, and gloves while using this machine. Be sure the gloves fit properly and do not have loose cuffs or drawstrings.
  - Use ear protectors or ear plugs.
  - Allow only responsible adults who are familiar with these safety rules and operating instructions to use your DR FIELD and BRUSH MOWER.
  - Keep your hands and feet away from the blades, belt, pulley, and concealed areas while the engine is running.
  - Keep people and pets away from your machine and out of the work area at all times. Disengage the blade and stop the engine if a person or pet is within 100 feet of the machine.
  - Children are often attracted to the machine and the mowing activity. Never assume that children will remain where you last saw them.
  - Never allow people to ride on the Mower.
  - Before mowing, clear the area of objects such as rocks, toys, wire, bones, sticks, etc.
  - Never remove or alter standard parts or add anything to the DR FIELD and BRUSH MOWER, especially all shields and guards.
  - Before and while moving backwards, look behind, and down for small children.
  - Use extra care when approaching blind corners, shrubs, trees, or other objects that may obscure your vision.
- 

## Safety with Gasoline - Powered Machines

---

### **WARNING**

Gasoline is a highly flammable liquid that gives off flammable vapor that can be ignited and cause a fire or explosion. Always follow these precautions:

- Never run the engine in an enclosed area or without proper ventilation as the exhaust contains carbon monoxide, an odorless, tasteless, and poisonous gas.
  - Store all fuel and oil in containers specifically designed and approved for this purpose. Keep away from heat and open flame and out of the reach of children.
  - Replace rubber fuel lines and grommets when worn or damaged or after 5 years of use, whichever comes first.
  - Fill the gasoline tank outdoors with the engine off and after the engine has cooled completely. Don't handle gasoline if you or anyone nearby is smoking.
  - If you spill gasoline do not start the engine. Move the machine away from the area until the gas vapors have dissipated.
  - Before performing engine maintenance or repairs, shut down the engine, disconnect the spark plug wire, and wait 5 minutes for the engine to cool.
  - Never change the engine governor settings or modify the engine speed.
  - Never check for an ignition spark with the spark plug or spark plug wires removed. Always use an approved spark tester.
  - Never tamper with safety devices. Regularly check their proper operation.
  - Allow the engine to cool completely before storing in any enclosed area.
  - Keep combustible substances away from the engine when it is hot. Never cover the machine while the muffler is still hot.
  - To reduce fire hazard, keep the engine and muffler free of debris build-up.
  - Do not operate the engine with the air cleaner or the carburetor air intake cover removed.
  - Do not use flammable solutions to clean the air filter.
  - Never operate the engine without the muffler and deflector, if so equipped. Inspect the muffler and deflector periodically and replace if necessary.
  - The muffler and engine become very hot and can cause a severe burn. Do not touch.
-

## Slope Operation

### **WARNING**

Use of machinery on slopes is a major factor in outdoor power equipment accidents. All slopes require caution. If you feel uneasy on a slope, do not mow it. Always take the following precautions when using this machine on slopes:

- Operate the machine up and down the face of slopes. Exercise extreme caution when changing direction on slopes.
- Never operate near drop-offs, ditches, or embankments or on slopes greater than 20 degrees.
- Never operate on wet or slippery slopes.
- Never park the tow vehicle on a steep grade or slope.

## General Safety

### **WARNING**

Safe operation of the TOW-BEHIND DR FIELD and BRUSH MOWER is necessary to prevent death or serious injury. Always take the following precautions when operating this machine:

- The TOW-BEHIND DR FIELD and BRUSH MOWER is designed to mow grass and brush. Do not use it for any other purpose.
- Always mount the remote control (if supplied) within easy reach of the operator's position.
- If the machine makes an unusual noise or vibration or if there are obstructions underneath the machine, shut off the tow vehicle and the DR FIELD and BRUSH MOWER engines. Wait five (5) minutes for the engine to cool. Disconnect the spark plug wires, keep them away from the spark plugs and then inspect the machine for clogs or loose parts. Clear any obstructions and repair and/or replace damaged parts.
- The mower blades are sharp. Wrap the blades or wear gloves and use extra caution when servicing.
- Always keep the machine in good, safe operating condition. Always make certain nuts and bolts are tight. Do not use substitute hardware.
- Use the TOW-BEHIND DR FIELD and BRUSH MOWER only in daylight.
- Always give undivided attention to the machine and your surroundings. Watch for traffic when mowing near roadways.
- Disengage the mower blades and exercise extreme caution when on or crossing drives, walks, or roads.
- If leaving the machine, shift the tow vehicle into neutral and set the parking brake; turn off the tow vehicle engine and remove its key. Turn off the DR FIELD and BRUSH MOWER engine and remove its key.
- Do not operate the mower when under the influence of alcohol, drugs, or medication.

## California Proposition 65

### **WARNING**

California Proposition 65:

- Engine exhaust and some of its constituents are known to the State of California to cause cancer, birth defects, and other reproductive harm.
- This product contains or emits chemicals known to the State of California to cause cancer, birth defects, and other reproductive harm.

## A Note to All Users

Under California law, and the laws of some other states, you are not permitted to operate an internal combustion engine using hydrocarbon fuels without an engine spark arrester. This also applies to operation on US Forest Lands. All TOW-BEHIND DR® FIELD and BRUSH MOWERS shipped to California, New Mexico and Washington State are provided with spark arresters. Failure of the owner or operator to maintain this equipment in compliance with state regulations is a misdemeanor under California law and may be in violation of other state and/or federal regulations. Contact your State Park Association or the appropriate state organization for specific information in your area.

No list of warnings and cautions can be all-inclusive. If situations occur that are not covered by this manual, the operator must apply common sense and operate this TOW-BEHIND DR FIELD and BRUSH MOWER in a safe manner. Contact us at [www.DRpower.com](http://www.DRpower.com) or call 1-800-DR-OWNER (376-9637) for assistance.

## Chapter 2: Setting Up The TOW-BEHIND DR FIELD and BRUSH MOWER

It may be helpful to familiarize yourself with the controls and features of your TOW-BEHIND DR FIELD and BRUSH MOWER by reviewing **Figure 2** before beginning these procedures. If you have any questions at all, please feel free to contact us at [www.DRpower.com](http://www.DRpower.com).

### TOW-BEHIND DR FIELD and BRUSH MOWER Controls and Features

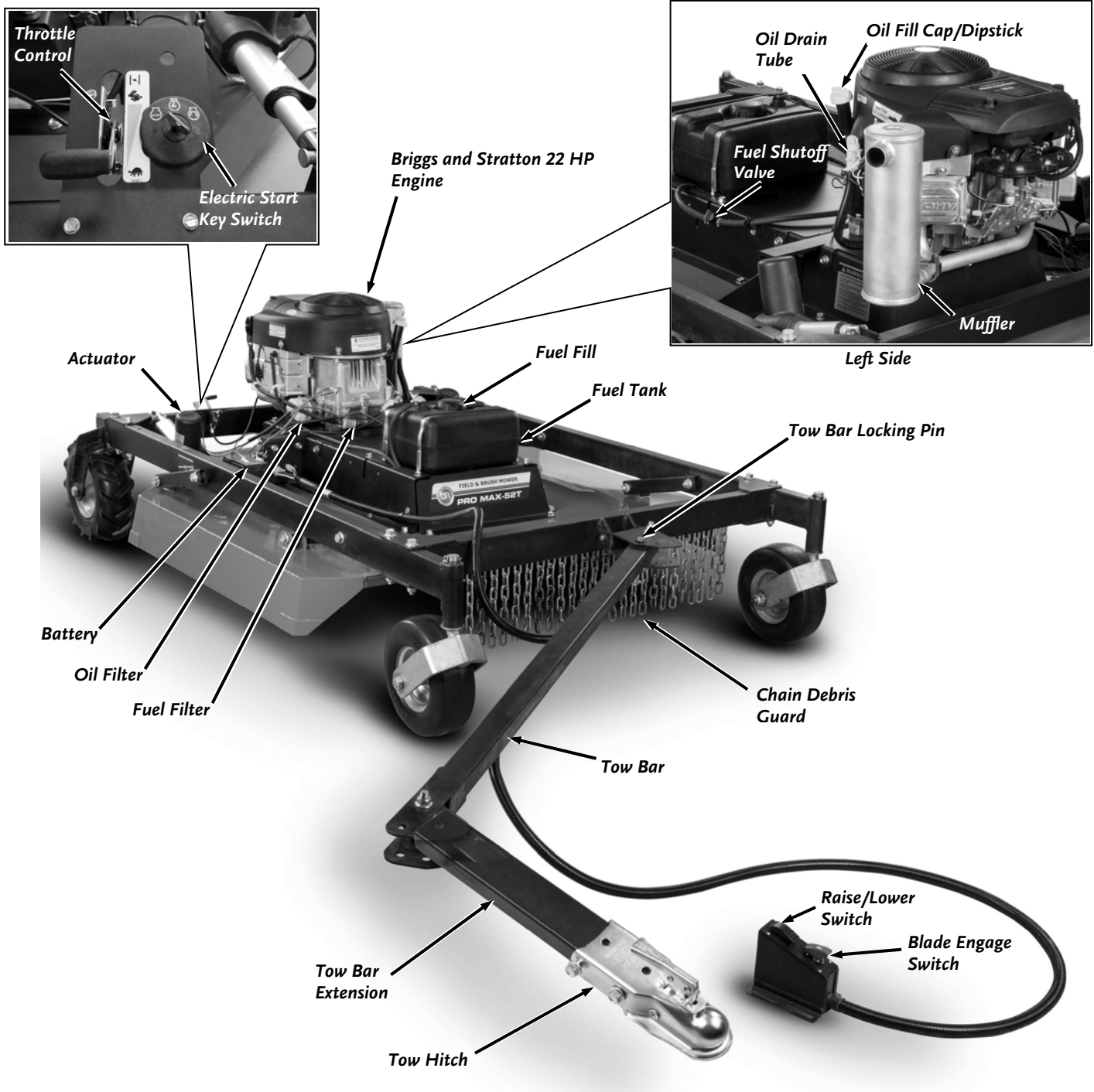

Figure 2

## Specifications

|   | <b>22 HP Pro-Max</b>   |
|---|--|
| <b>Engine</b>   | See your Engine Manual for oil capacity and other Engine specifications.                 |
| <b>Starting System</b>                                | Electric Start   |
| <b>Fuel Tank</b>                                      | 2.5 Gal. (9.46 L), Gasoline, Unleaded  |
| <b>Battery</b>  | 12 Volt 9Ah  |
| <b>Wheels</b>   | Front: 11 X 4-5, Flat Free.<br>Rear: 13 x 5-6, Lugged (with tube)                        |
| <b>Tether Length</b>                                  | 14'-5"   |
| <b>Distance From Centerline To Outer Cutting Edge</b> | 72" - full offset<br>53.5" - mid offset  |
| <b>Number of Offset Positions</b>                     | 5 (2 Left, 2 Right, 1 Center)  |
| <b>Adjustable Cutting Height</b>                      | From 4" min. to 7-1/2" max.  |
| <b>Cutting Width</b>                                  | 52"  |
| <b>Cutting Capacity</b>                               | 6' high grass, 8'-high weeds & brush, 3" thick saplings                                  |
| <b>Blade Tip Speed</b>                                | 18,500 - 19,000 ft/min   |
| <b>Blades</b>   | Break Away/Swing, Air Tipped   |
| <b>Deck</b>   | 12 GA Welded Steel   |
| <b>Discharge</b>                                      | Rear   |
| <b>Spindle</b>  | 1-3/8" Dia. Shaft with 2 Sealed 30 mm Bearings   |
| <b>Belt</b>   | B53  |
| <b>Electric Clutch</b>                                | 95 ft-lb   |
| <b>Fuses</b>  | 20 AMP Type AGC Fuse (Engine Alternator Circuit)<br>7 AMP Type AGC Fuse (Clutch Circuit) |
| <b>Max Speed Mow/Tow</b>                              | 5 mph on flat terrain, 4 mph on rough terrain  |
| <b>Tongue Weight</b>                                  | 11 lbs.  |
| <b>Machine Dimensions</b>                             | 156" L x 53.2 " W x 32.5" T  |
| <b>Machine Weight</b>                                 | 566 Lbs.   |

## Assembling the TOW-BEHIND DR FIELD and BRUSH MOWER

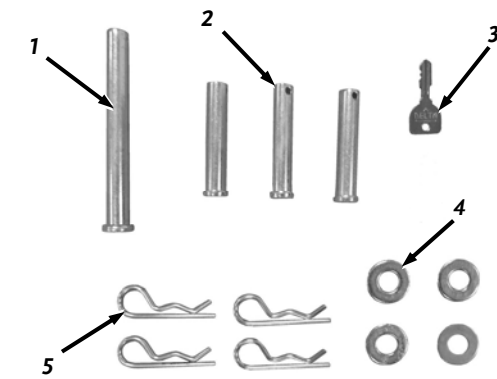

Figure 3

### Hardware Supplied in Product Package (Figure 3 and Table below):

| Item # | Part # | Description                         | Qty |
|--------|--------|-------------------------------------|-----|
| 1      | 18737  | Pin, Clevis, 1/2" OD X 4.5" LG      | 1   |
| 2      | 25549  | Pin, Clevis, 1/2" X 2-1/2", TRT     | 3   |
| 3      | 15720  | Key, Ignition Switch                | 1   |
| 4      | 23499  | Washer, SAE Flat, 1/2", ZP          | 4   |
| 5      | 16003  | Pin, Hair, 1/2" To 9/16", .12" Wire | 4   |

Compare the hardware of the Product Package with the "Parts Supplied" list above. If you have any questions please contact us at [www.DRpower.com](http://www.DRpower.com).

### Attaching the Tow Bar to the Push Bar

The Tow Bar can be installed for offsetting to the right or left depending on which side of the Tow Vehicle you choose to mow. See section "Offset Mowing" in Chapter 3 to determine how the Tow Bar should be installed for your needs. The following steps describe installing the Offset Bracket to allow offsetting to the right side of the Tow Vehicle.

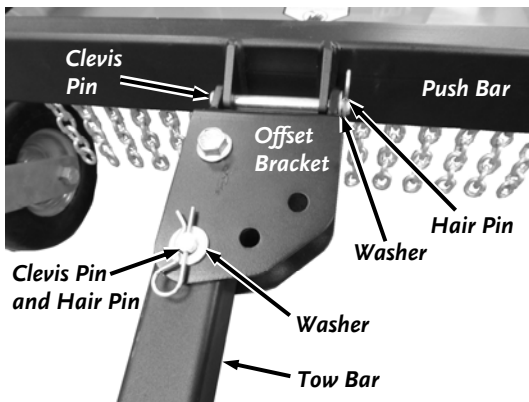

Figure 4

1. Secure the Offset Bracket to the Push Bar in the configuration shown (for left side offset) using the 4.5" long Clevis Pin, Washer, and Hair Pin (Figure 4).
2. Align the Tow Bar so it is pointed straight out from the Mower and install a Clevis Pin, Washer, and Hair Pin in the Offset Bracket to lock the Tow Bar in position.

### **! WARNING**

Always install the Clevis Pins from the bottom with the Washers and Hair Pins on top to prevent the Hair Pin from being pulled out by tall grass or bushes.

3. Align the Tow Bar Extension with the Tow Bar and install a Clevis Pin, Washer, and Hair Pin in the Tow Bar to lock the Tow Bar Extension in place (Figure 5).

### Connecting the Remote Control

#### Tools Needed:

- Wire Cutters
- 5/16" Socket w/Ratchet

1. Use Wire Cutters to cut the Cable Tie that is securing the Remote-Control Cable to the Frame for shipping.
2. Remove the Screws securing the Cable Clamps to the Tow Bar using a 5/16" Socket w/Ratchet.
3. Route the Remote-Control Cable over the Push Bar and on top of the Tow Bar. Leave some slack in the Remote-Control Cable around the Push Bar to allow for Mower Deck movement.

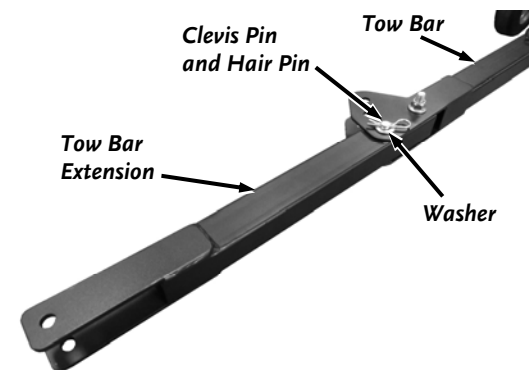

Figure 5



- Gently spread open the Cable Clamps and install them onto the Control Cable, positioning the clamps on the tow bar keeping the Control Cable flat and centered on the Tow Bar (**Figure 6**).
- Line up the hole in the Clamp with the hole in the Tow Bar and secure the Clamps to the Tow Bar with the Screws using a 5/16" Socket w/Ratchet.

### Adding Oil and Gasoline

**Tip:** To avoid confusion, we recommend leaving the caps on the Fuel and Oil Fills until you are ready to pour either gasoline or oil into the correct Fill.

| Engine Oil and Fuel Capacities |                 |                  |
|--------------------------------|-----------------|------------------|
|                                | Oil (SAE 30 HD) | Fuel (Unleaded)  |
| Briggs and Stratton – 22 HP    | 64 oz. w/Filter | 2.5 Gal (9.46 L) |

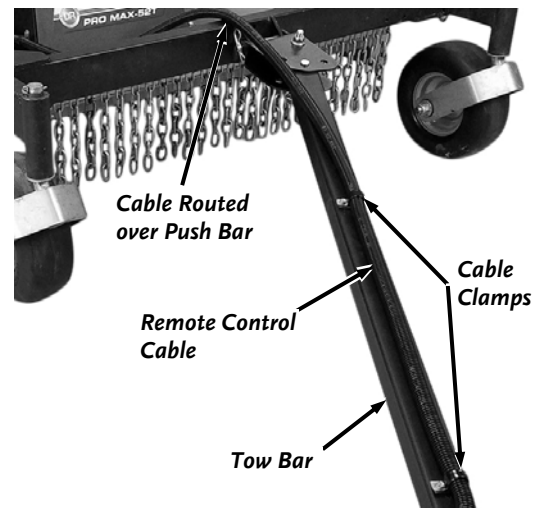

Figure 6

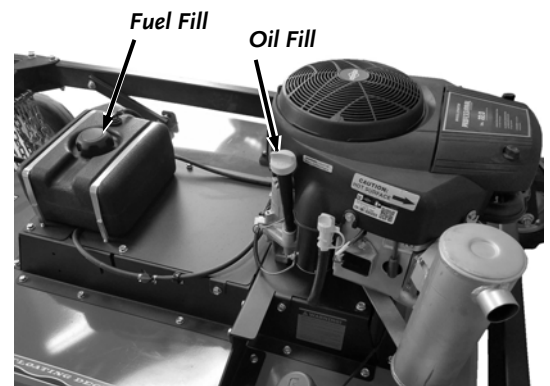

Figure 7

### NOTICE

- You must add oil before starting the engine. This machine is shipped without oil. Traces of oil may be in the reservoir from factory testing, but **YOU MUST ADD OIL BEFORE STARTING THE ENGINE**. Fill the reservoir slowly, checking the level frequently to avoid overfilling.
- To get an accurate reading when checking the oil level:
  - The machine should be on a level surface.
  - The dipstick **SHOULD** be screwed down.

**Note:** Use only SAE 30 HD (High Detergent) oil. Other types of oil could cause problems with the operation of your machine. Please refer to your Engine Owner's Manual for detailed oil information.

**Note:** See the Engine Owner's Manual for more detailed information.

- Place the machine on a level surface and remove the Oil Fill Cap/Dipstick (**Figure 7**).
- Initially add 32 oz. of SAE 30 High Detergent oil (recommended by the Engine Manufacturer) into the Oil Fill and wait one minute for the oil to settle.
- Replace the Dipstick fully and then remove it to check the oil level. Continue adding a few ounces of oil at a time, rechecking the Dipstick until the oil reaches the fill mark. Be careful not to overfill.
- Replace the Dipstick and turn it a quarter turn clockwise to lock it fully into position.
- Remove the Fuel Cap and fill the gas tank to within 1-1/2" below top of fill neck (to allow for fuel expansion) with fresh, unleaded gas. Replace the Fuel Cap when finished.

### Connecting the Battery Wire

We ship all Electric-Starting machines with the green negative (ground) Battery Wire disconnected. This prevents the Battery from discharging during shipment. Before using your TOW-BEHIND DR FIELD and BRUSH MOWER, you must connect the green negative Battery Wire.

- Push the negative Wire Connector fully onto the negative terminal of the Battery (**Figure 8**).

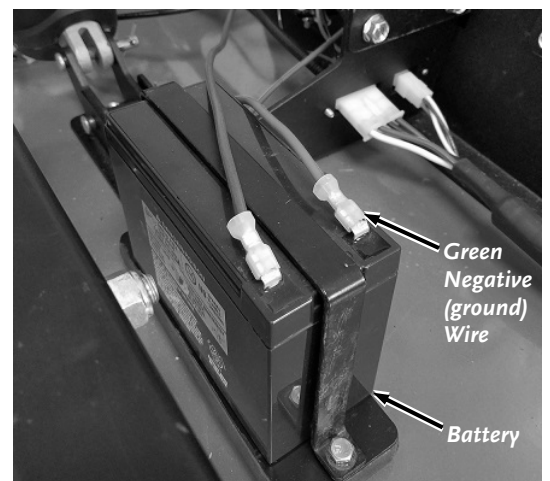

Figure 8

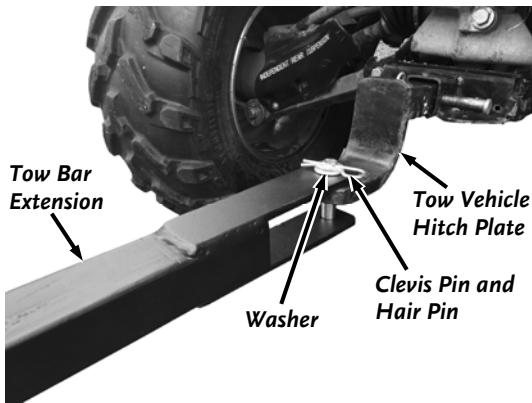

Figure 9

## Connecting the TOW-BEHIND DR FIELD and BRUSH MOWER to your Tow Vehicle

The pin type hitch that comes installed on the TOW-BEHIND DR FIELD and BRUSH MOWER Tow Bar is quick and easy to attach to Tow Vehicles with a hole in the Hitch Plate. A Ball Hitch Kit is also provided if you would prefer attachment to a 2" Ball on the Tow vehicle. Go to the next page for info on installation and operation of the Ball Hitch.

1. Move your Tow Vehicle to a flat area and set the Parking Brake.
2. Align the Tow Hitch to the hole in the center of your Hitch Plate with the top portion of the Tow Hitch above the Hitch Plate and the bottom portion below (Figure 9).
3. Secure the Hitch with the Clevis Pin and Hair Pin.



Figure 10a: ATV Mounting

## Attaching the Remote-Control

**NOTICE**  
Be sure to route the Remote-Control Cable away from the muffler of the tow vehicle to prevent damage to the Cable.

1. Position the Remote Control on your Tow Vehicle within reach of the seated Tow Vehicle driver (Figure 10a and 10b).
2. Secure the Remote Control to a fixed object on your Tow Vehicle using the mounting holes at either end of the Control Box with Cable Ties or equivalent.

**Tip:** Mounting the Remote Control on the side of the Tow Vehicle that the mower is offset will make it easier to access while observing the mower.

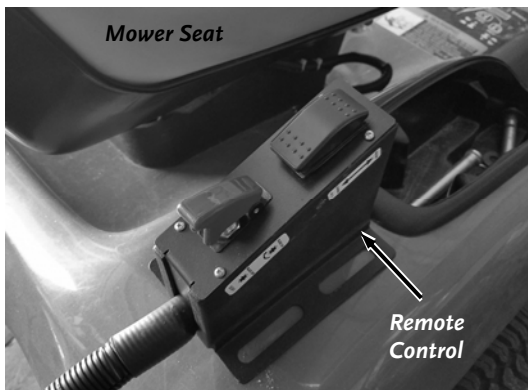

Figure 10b: Mower Mounting

## Checking the Rear Tire Pressure

- Tools Needed:**
- Tire Pressure Gauge
  - Air Compressor

1. Remove the Valve Stem Protective Cap (Figure 11) and check the tire pressure with a Tire Pressure Gauge.
2. Compare the tire pressure reading from step 1 with the manufacturer's recommended tire pressure stamped on the side of the tire.
3. If the pressure is too low, add air through the Valve Stem with an air hose.
4. Replace the Valve Stem Protective Cap when finished.

**WARNING**  
Do not over inflate the tires. Inflate to the manufacturers recommended pressure found on the tires.



Figure 11

## Installing and Operating the Ball Hitch Kit

### Parts Supplied (Figure 12):

| Item # | Part # | Description                                  | Qty |
|--------|--------|--|-----|
| 1      | 24648  | Receiver, 2", Class II,.....                 | 1   |
| 2      | 36308  | Extension, Tow Bar, Ball Hitch .....         | 1   |
| 3      | 25312  | Chains, Safety, 36", Individual .....        | 2   |
| 4      | 33349  | Bolt, Hex, Flange, 1/2-13 X 5".....          | 2   |
| 5      | 23499  | Washer, .53" ID X 1.06" OD X .095", ZP ..... | 4   |
| 6      | 33335  | Nut, Nylon Lock, Flanged, 1/2-13.....        | 2   |
| 7      | 33443  | Link, Chain Threaded Connector .....         | 2   |

Compare the contents of the Parts Box with the "Parts Supplied" list above and Figure 1. If you have any questions please contact us at [www.DRpower.com](http://www.DRpower.com) or call 1-800-DR-OWNER (376-9637) for assistance.

### Tools Needed:

- Two 3/4" Wrenches
- 10mm Wrench

## ! WARNING

Before performing this kit installation, you must first shut off the engine, wait five minutes to allow parts to cool and disconnect the spark plug wires, keeping them away from the spark plugs.

### Installing the Ball Hitch Kit

1. Attach a Threaded Chain Connector to the end of each safety Chain and tighten with a 10mm Wrench (**Figure 13**).

**Note:** In order to attach the Chains in Step 3, position the Chain Connector so that the shorter end is on the side connected to the Safety Chains (**Figure 13**).

2. Position the Receiver on the Ball Hitch Extension from the kit and secure the Front End loosely by hand with a 1/2-13 x 5" Flanged Bolt, Flanged Locknut, and two Washers (**Figure 14**).
3. Secure the Rear End of the Receiver and the Safety Chains loosely by hand with a 1/2-13 x 5" Flanged bolt, Flanged Locknut, and two Washers.

**Note:** Position each Washer between the Safety Chain and the Receiver.

4. Using two 3/4" Wrenches, Tighten the Hardware from Steps 2 and 3.

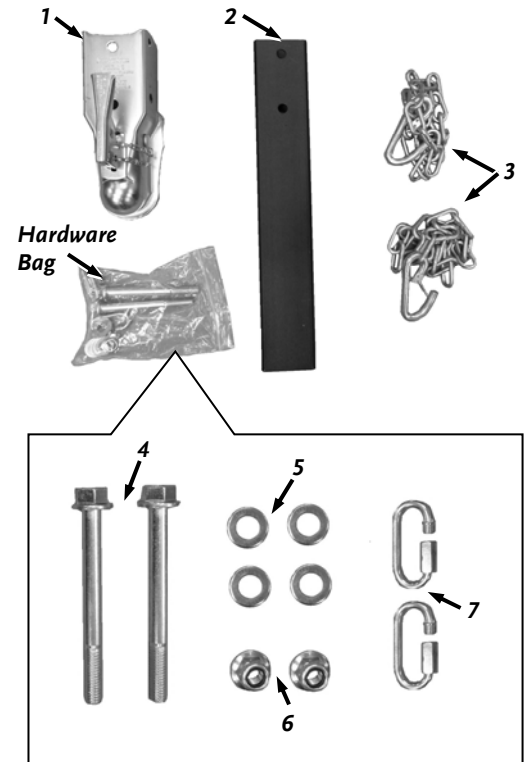

Figure 12

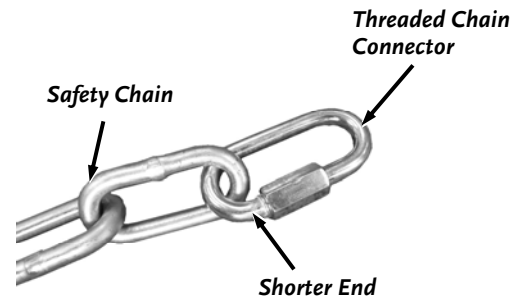

Figure 13

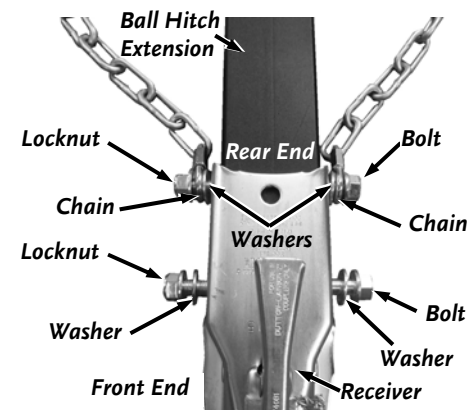

Figure 14

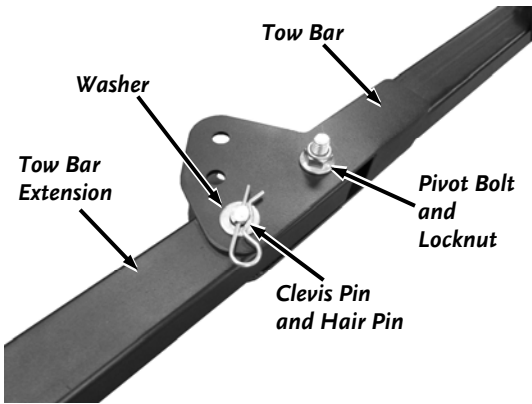

Figure 15

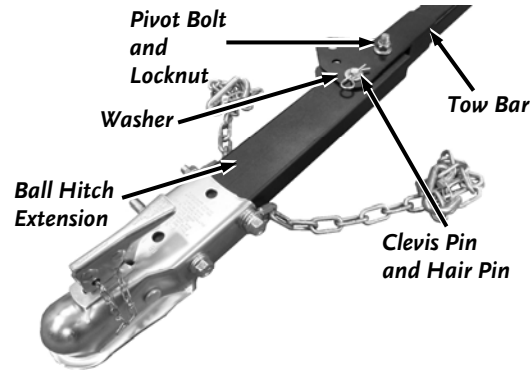

Figure 16

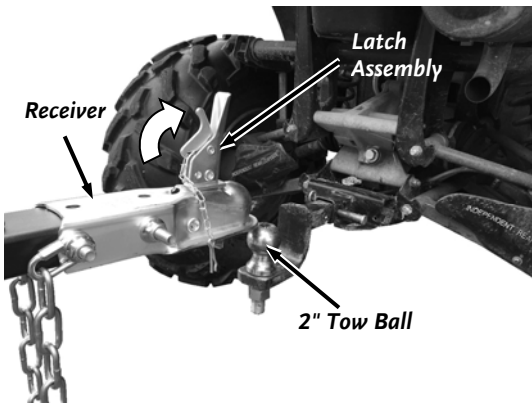

Figure 17

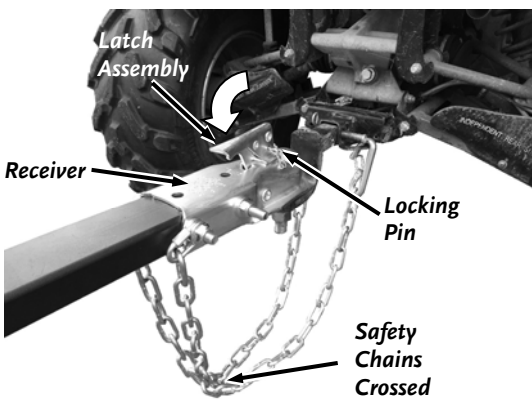

Figure 18

5. Remove the Hair Pin, Washer, and Clevis Pin from the Tow Bar (**Figure 15**).
6. Remove the Pivot Bolt and Locknut that is securing the Tow Bar Extension to the Tow Bar using two 3/4" Wrenches. Store the Tow Bar Extension for future use.
7. Secure the Ball Hitch Extension from the kit to the Tow Bar using the Pivot Bolt and Locknut you removed in the last step (**Figure 16**).
8. Reinstall the Clevis Pin, Washer, and Hair Pin in the Tow Bar to lock the Ball Hitch Extension in place.

**Note:** Make sure the Washer and Hair Pin are always installed on the top side. This prevents the Hair Pin from catching on tall grass.

### Connecting the Tow Behind DR Field and Brush Mower to the Tow Vehicle

#### **! WARNING**

- The Ball Hitch Kit for the Tow Behind DR Field and Brush Mower is designed for ATV, UTV, or Tractors with a 2" Ball installed for towing.
- Do not exceed 10 mph when towing.
- Never tow on roads.
- Never tow with a truck or other road vehicle.

1. Remove the Locking Pin and Pull the Latch assembly on the Receiver up into the open position (**Figure 17**). Position the Receiver onto the tow vehicle's tow ball (must be a 2" tow ball).
2. Close the Latch Assembly on the Tow Hitch Assembly to lock it onto the Tow Ball (**Figure 18**). Attach the towing Safety Chains to the tow vehicle ensuring there is enough slack for turning.

**Note:** When attaching the Safety Chains, Attach the left chain to the right anchor and the right chain to the left anchor so that that the Safety Chains cross each other under the Ball Hitch.

3. Insert the Locking Pin into the hole in the Latch Assembly.

#### **! WARNING**

Making sure the mower is securely attached to the ATV, UTV, or Tractor is the responsibility of the owner/operator. Failure to securely attach the mower can cause loss of control of the tow vehicle or the mower being separated from the vehicle, resulting in serious injury or death.

## Receiver Adjustment Check

1. Place a 2" ball in the socket of the receiver and close the latch assembly (**Figure 19**). Verify that the locking trigger is properly engaged in its detent.
2. Pull on the ball and/or receiver, trying to remove the ball from the socket. If the ball moves more than 1/16" in the receiver's socket, the clamp requires adjustment. Follow the proper adjustment procedure in the following steps.

## Receiver Adjustment

1. With the 2" ball in the socket of the receiver, close the latch of the receiver completely (**Figure 20**). Verify that the locking trigger is properly engaged in its detent.
2. Tighten the lock nut on the underside of the receiver until the spring between the nut and the clamp is fully compressed. Then back off the lock nut 1/2 turn or just enough that the latch is able to clamp and unclamp from the ball.

If you have any questions please contact us at [www.DRpower.com](http://www.DRpower.com) or call 1-800-DR-OWNER (376-9637) for assistance.

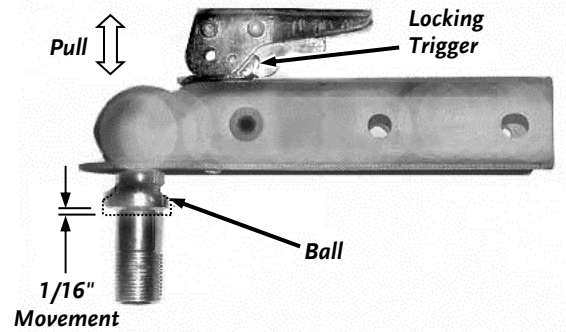

Figure 19

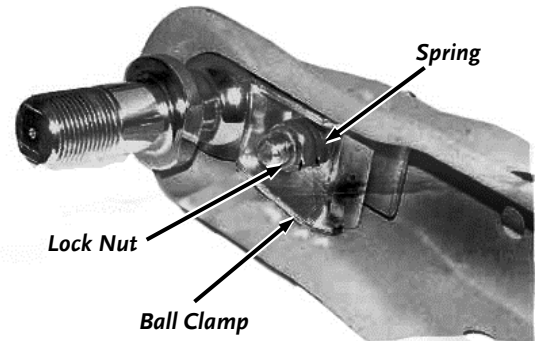

Figure 20

## Chapter 3: Operating the TOW-BEHIND DR FIELD and BRUSH MOWER

---

This chapter covers the procedures for starting and stopping your new TOW-BEHIND DR FIELD and BRUSH MOWER and discusses basic operation features. You may find it helpful to review the TOW-BEHIND DR FIELD and BRUSH MOWER Controls and Features on page 6 before reading this chapter.

### **WARNING**

- This machine is designed for cutting grass and brush. Never use this machine for any other purpose as it could cause serious injury.
- Contact with internal rotating parts will cause serious personal injury. Never put hands, face, feet, or clothing under the deck or near the discharge area with the engine running.
- Before performing any maintenance procedure or inspection, stop the Engine and wait five (5) minutes to allow all parts to stop and cool. Disconnect the spark plug wires keeping them away from the spark plugs.

### **Operating Parameters**

We recommend a few types of Tow Vehicles for the TOW-BEHIND DR FIELD and BRUSH MOWER. The Tow Vehicle may be either 2 or 4-wheel drive, but some vehicle types are not suitable for rough, hilly terrain or heavy brush conditions. See the Tow Vehicle Restrictions section below.

- ATV
- Lawn/Garden Tractor (17 HP and above and weighing at least 500 pounds)
- Utility Vehicle
- Compact or Sub-Compact Tractor

### **Tow Vehicle Restrictions:**

- You must be able to secure the Blade Engage/Disengage Remote Control of the TOW-BEHIND DR FIELD and BRUSH MOWER within easy reach of the driver seated on the Tow Vehicle.
- Riding Lawn Mowers with Engines under 17 HP and weighing less than 500 pounds are not suitable for use on slopes greater than 5°.
- Never operate your TOW-BEHIND DR FIELD and BRUSH MOWER on slopes greater than 20° using any type of Tow Vehicle.
- If your Tow Vehicle will not travel by itself over the terrain you plan to use it with the TOW-BEHIND DR FIELD and BRUSH MOWER, then it will not be suitable as a Tow Vehicle over that terrain.

**Tip:** Riding Lawn Mowers will work best as a Tow Vehicle with their cutting deck removed.

### **CAUTION**

- We do not recommend driving over 5 mph on flat terrain and over 4 mph on rough terrain while operating your TOW-BEHIND DR FIELD and BRUSH MOWER.
- Never use a truck (2 or 4wd) or jeep to operate the TOW-BEHIND DR FIELD and BRUSH MOWER. It would be difficult to see and you cannot operate the mower controls from these types of tow vehicles. Using these vehicles will void the TOW-BEHIND DR FIELD and BRUSH MOWER warranty.

## Before Starting the Engine





### **! WARNING**

Inspect the area where you will be working. The site must be free of potentially hazardous obstacles such as glass, large stones, sticks, wire, rope, and string-like materials. Make sure there are no people or animals in the area around the TOW-BEHIND DR FIELD and BRUSH MOWER.

1. Check the oil level every time you use the machine. See your Engine Owner's Manual.
2. Check the gasoline level.
3. Open the Fuel Shut-Off Valve on the left-hand side of the Mower (**Figure 21**).
4. Make sure the Blade Switch Safety Cover is pushed down to the disengaged position (**Figure 22**).

**Note:** The Blade Switch Safety Cover must be pushed down or the Engine will not start.



## Starting

1. Ensure the Blade Switch Safety Cover is down (**Figure 22**).
2. When starting a cold Engine, push the Throttle Control Lever up to the Choke  position (**Figure 23**). When starting an already warm Engine, push the Throttle Control Lever to the Run  position.
3. Turn the Key Switch to the Start  position until the Engine starts, then release. The Key will snap back to the center On  position and the Engine will continue to run.
4. As the Engine warms up, slowly adjust the Throttle to the Run  position. Wait until the Engine runs smoothly before each Throttle adjustment. For maximum performance, operate the Engine with the Throttle in the Run position.

## Stopping the Engine

### **NOTICE**

Never stop the engine by moving the throttle control lever to the choke position. This could cause an engine backfire resulting in engine damage.

1. Disengage the Blades by pushing the Blade Switch Safety Cover down (**Figure 22**).
2. Move the Throttle Control Lever all the way down to the Idle  position and turn the Key to Stop  (**Figure 23**).
3. Remove the Key for safety.

**Note:** Close the Fuel Shut-Off Valve when transporting or storing the TOW-BEHIND DR FIELD and BRUSH MOWER (**Figure 21**).

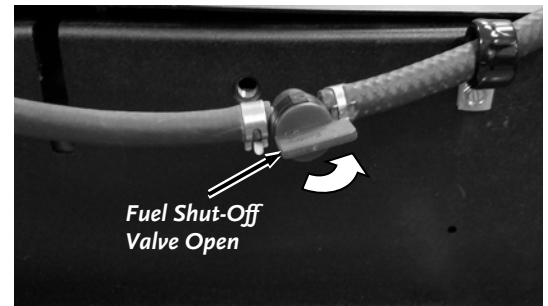

Figure 21



Figure 22

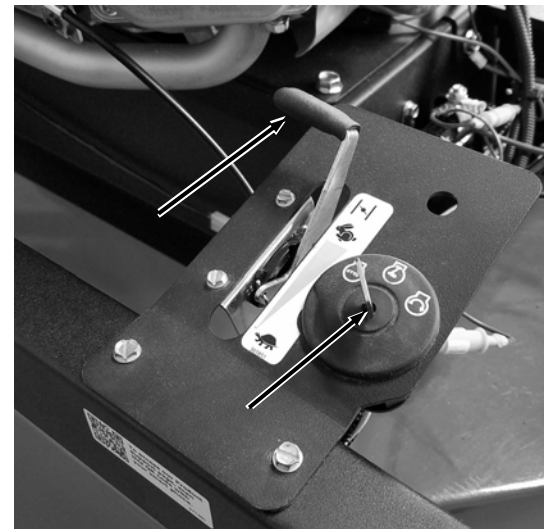

Figure 23

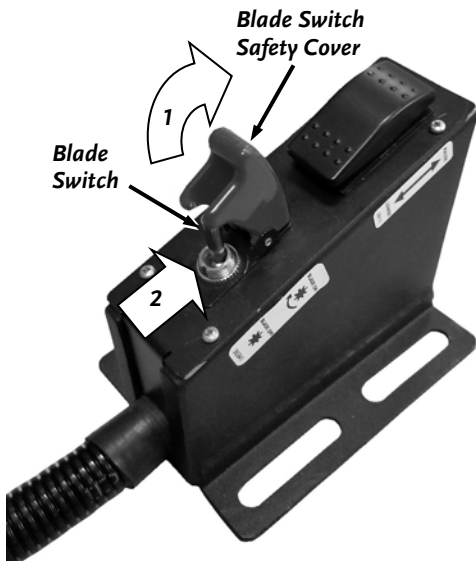

Figure 24

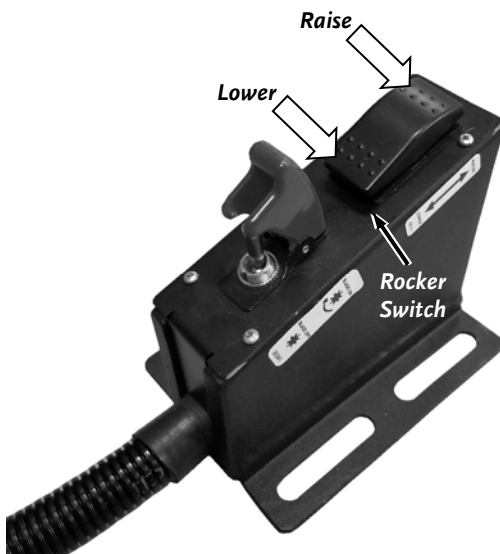

Figure 25



Figure 26

### Engaging the Blades

1. Engage the Blades by pulling up on the Blade Control Safety Cover and pushing forward on the Blade Control Switch (**Figure 24**).

### Stopping the Blades

1. Push down on the Blade Control Safety Cover (**Figure 22**).

### Adjusting the Mower Deck Height

#### **! WARNING**

- Shut off the Brush Mower Engine before adjusting the Deck height or serious injury may result. The Blades could sever your foot if it goes under the deck with the Engine running.
- Never get off the Tow Vehicle without first stopping the Blades and shutting off the Tow Vehicle Engine.

#### **! CAUTION**

Keep your foot clear of the Mower Deck when adjusting the height. You could pinch your foot if it is under the Deck.

**Note:** The TOW-BEHIND DR FIELD and BRUSH MOWER Deck cutting Height ranges from a minimum of 4" to a maximum of 7.5".

1. To Lower the cutting Height of the Mower, press "Lower" on the Rocker Switch (**Figure 25**) until the Sway Brace is aligned with the desired cutting height lines on the Height Adjust label (**Figure 26**).
2. To Raise the cutting Height, press "Raise" on the Rocker Switch until the Sway Brace is aligned with the desired cutting height lines on the Height Adjust label.



## Offset Mowing

The Tow Bar allows you to offset the cutting path of the TOW-BEHIND DR FIELD and BRUSH MOWER up to 72" from the center of the Tow Vehicle. The provided offset positions are "No Offset" (in line with Tow Vehicle), "Middle Offset" (53-1/2" from center of Tow Vehicle) or "Full Offset" (72" from the center of the Tow Vehicle). Offset mowing allows you to mow closer to equipment, trees, and fences while the Tow Vehicle stays at a safer distance. It also allows you to drive in an area already cut and not through grass and brush that hasn't been cut yet.

See the section "Changing the Tow Bar Offset Direction" on the next page to allow offsetting the Mower to the left side of the Tow Vehicle.

### **⚠ CAUTION**

When performing offset mowing, always be sure that the Tow Bar offset and the Tow Bar Extension offset match (**Figure 27**). This ensures the Tow-Behind DR Field and Brush Mower will track parallel to the tow vehicle path.

#### **Offsetting the Tow Bar:**

1. Remove the Hair Pin, Washer, and Clevis Pin that secures the Tow Bar in the Offset Bracket (**Figure 28**).
2. Rotate the Tow bar to the Desired Offset (No Offset, Middle Offset, or Full Offset).
3. Reinstall the Clevis Pin, Washer, and Hair Pin to Lock the Tow Bar in Place.

### **⚠ WARNING**

Always install the Clevis Pins from the bottom with the Washers and Hair Pins on top to prevent the Hair Pin from being pulled out by tall grass or bushes.

#### **Offsetting the Tow Bar Extension:**

1. Remove the Hair Pin, Washer, and Clevis Pin that secures the Tow Bar Extension to the Tow Bar (**Figure 29**).
2. Rotate the Tow Bar Extension so that the Offset angle is the same as at the Offset Bracket (No Offset, Middle Offset, or Full Offset).
3. Reinstall the Clevis Pin, Washer, and Hair Pin to Lock the Tow Bar Extension in Place.

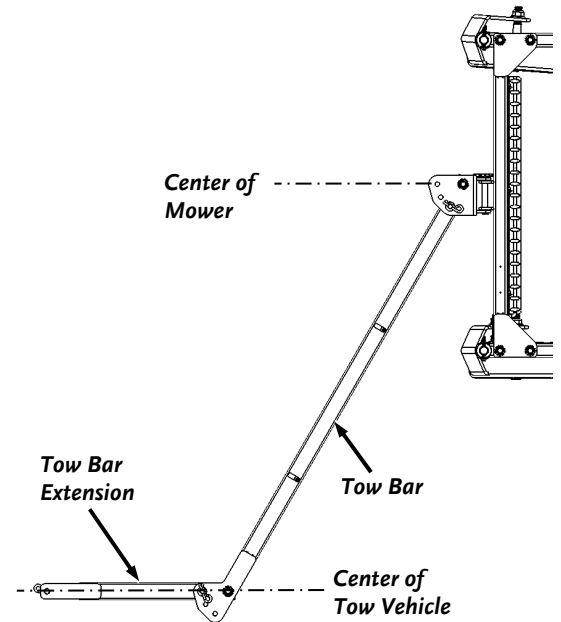

**Figure 27: Full Offset Shown**

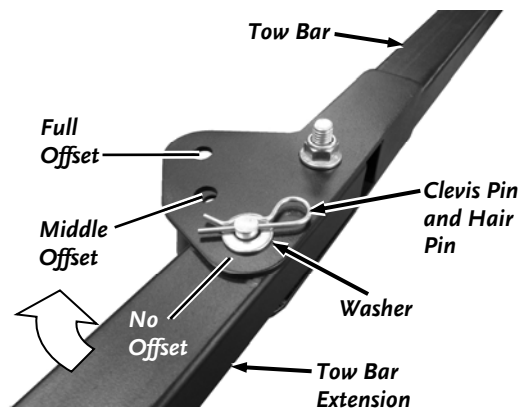

**Figure 29**

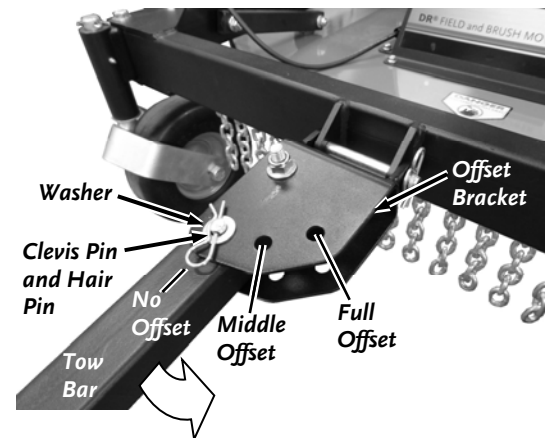

**Figure 28**

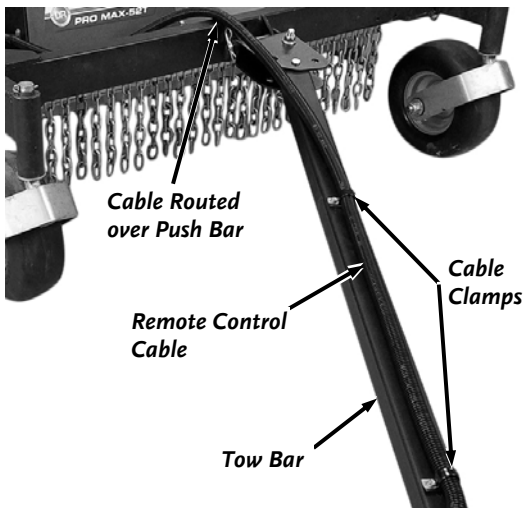

Figure 30

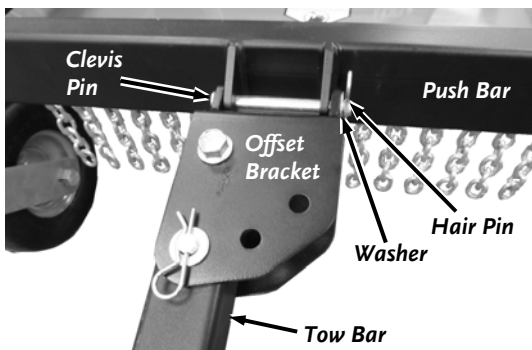

Figure 31

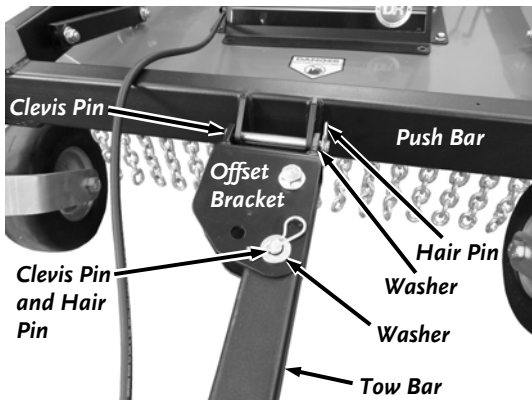

Figure 32

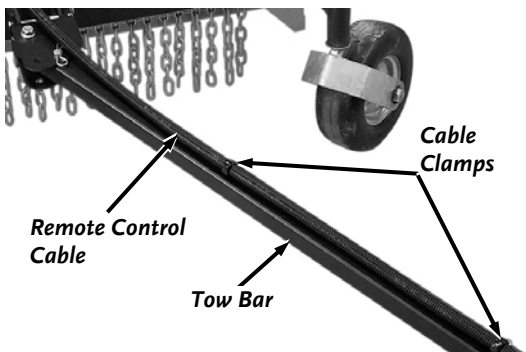

Figure 33

## Changing the Tow Bar Offset Direction

The Tow Bar can be installed for offsetting to the right or left depending on which side of the tow vehicle you choose to mow. The following steps describe installing the Offset Bracket to allow offsetting to the left side of the Tow Vehicle.

### Tools Needed:

- 5/16" Socket w/Ratchet

1. Remove the Screws securing the Cable Clamps and Remote Control Cable to the Tow Bar using a 5/16" Socket w/Ratchet (**Figure 30**).
2. Support the Tow Bar as you remove the Hair Pin, Washer and Clevis Pin that secures the Offset Bracket to the Push Bar (**Figure 31**).
3. Turn the Tow Bar over to position the Offset Bracket for left side offset and reinstall it to the Push Bar with the Hair Pin, Washer and Clevis Pin (**Figure 32**).
4. Remove the Clamps from the Remote Control Cable and rotate them so that they are facing the opposite direction, then reinstall them onto the cable (**Figure 33**).
5. Route the cable over the Tow Bar and line up the holes in the Cable Clamps with the holes in the Tow Bar. Keep the Cable flat and centered on the Tow Bar.
6. Secure the Cable Clamps to the Tow Bar with the Screws using a 5/16" Socket w/Ratchet.
7. Remove the Hair Pins, Washers and Clevis Pins that are at the Tow Bar and Tow Bar Extension offsets and reinstall with the Washers and Hair Pins on top.

### **! WARNING**

Always install the Clevis Pins from the bottom with the Washers and Hair Pins on top to prevent the Hair Pin from being pulled out by tall grass or bushes.

8. To adjust the offset, see section "Offset Mowing" on the previous page.

## *Slopes and Uneven Terrain*

---

### **WARNING**

- Check the owner's manual for your tow vehicle to determine its recommended towing capabilities on slopes.
  - When operating the TOW-BEHIND DR FIELD and BRUSH MOWER over uneven terrain or slopes, use extreme caution not to tip over the machine.
  - Never use the TOW-BEHIND DR FIELD and BRUSH MOWER on slopes greater than 20 degrees. Doing so could result in serious injury or damage to your machine.
  - If you need to mow on sloping terrain less than 20 degrees, mow up and down, never across the slope, for better control.
- 

## *If the machine gets hung up*

---

### **WARNING**

- If you need to leave the tow vehicle to clear debris from the mower deck, set the parking brake and shut off the tow vehicle engine, disengage the mower blades, shut off the TOW-BEHIND DR FIELD and BRUSH MOWER engine and disconnect the spark plug wires.
  - Never touch the exhaust areas when reaching for the spark plugs; they may be very hot.
- 
1. Disengage the Blades and STOP the Engine. NEVER try to free the machine from stumps or debris with the Blades engaged.
  2. Try driving over or backing away from the obstacle.

## *Cutting Brush and Saplings*

- The cutting capacity is 3" saplings.
- When cutting woody material, small saplings, etc., allow the machine to ride up and over material slowly. Adjust your forward speed to varying conditions.
- After cutting brush, etc., you may want to mow over it again to remove any remaining branches. It works best to mow from the trunk end toward the top as brush lies on the ground.

## *Cutting Wet and Heavy Growth*

- Avoid steep slopes and other slippery areas.
- Use a lower, slower speed when mowing in wet conditions.

## Chapter 4: Maintaining the TOW-BEHIND DR FIELD and BRUSH MOWER

This chapter covers regular maintenance procedures that will ensure the best performance and long life of your TOW-BEHIND DR FIELD and BRUSH MOWER. For Engine maintenance, please refer to the Engine Owner's Manual that came with your machine. Service intervals listed in the checklist below supersede those listed in the Engine Owner's Manual.

### **! WARNING**

When performing any adjustment or maintenance, you must first disengage the Blade, shut off the engine, wait five minutes to allow parts to cool and disconnect the spark plug wires, keeping them away from the spark plugs.

### Regular Maintenance Checklist

**Note:** Consider the service intervals shown as maximum under normal operating conditions. Increase frequencies under extremely dirty or dusty conditions.

| PROCEDURE  | BEFORE EACH USE | EVERY 25 HOURS | EVERY 100 HOURS |
|--|-----------------|----------------|-----------------|
| Check Engine Oil Level   | ▲               |                |                 |
| Check General Condition, e.g. nuts, bolts, welds, etc.                 | ▲               |                |                 |
| Check the Blades Sharpness   | ▲               |                |                 |
| Clean Engine Exterior & Cooling Fins                                   | ▲               |                |                 |
| Check Cable connections  |                 | ▲              |                 |
| Check Tire Pressure of rear Wheels (psi on side of tire)               |                 | ▲              |                 |
| Change Engine Oil and Filter. Note: 1 <sup>st</sup> time after 5 hours |                 | ▲              |                 |
| Replace Air Filter   |                 | ▲              |                 |
| Lubricate Wheel Bearings   |                 | ▲              |                 |
| Check Drive Belt Condition   |                 | ▲              |                 |
| Replace Spark Plug(s)  |                 |                | ▲               |
| Replace In-line Gas Filter   |                 |                | ▲               |



Figure 34

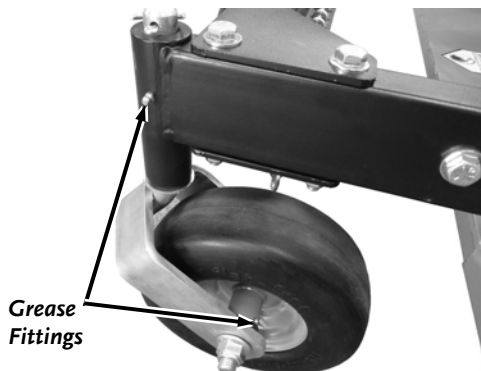

Figure 35

### Lubrication

#### Tools and Supplies Needed:

- Grease gun with Multipurpose Automotive Grease
- Clean Rags

#### Lubricate Wheel Bearings and Casters:

1. Clean the Grease Fitting with a clean Rag (**Figure 34 and 35**).
2. Lubricate each Rear Wheel and Caster Shaft with Multipurpose Automotive Grease using a grease gun on the Grease Fitting.

## Removing and Replacing the Engine Oil and Filter

**Note:** Refer to the Engine Owner's manual for more detailed instructions for Engine maintenance. Drain the oil when the Engine is warm. Warm oil drains quickly and completely.

### Tools and Supplies Needed:

- Oil Filter Wrench (available at local auto parts or hardware store)
- Rags and an approved container for used oil
- SAE 30 High Detergent Oil

1. Remove the Oil Fill Cap/Dipstick (**Figure 36**).
2. Turn the Oil Drain Cap a quarter turn counterclockwise and open the end of the Drain Hose Assembly.
3. Position an appropriate drain container near the Drain Hose.
4. Remove the Oil Drain Hose Assembly from the Bracket and lower the Cap end over the Container to drain.
5. The Engine Oil Filter is located on the side of the Engine (**Figure 37**). Using an Oil Filter Wrench, or grasping the Oil Filter firmly with your hand, unscrew the Oil Filter counterclockwise from the Engine. **BE SURE THAT THE OLD FILTER GASKET COMES OFF WITH THE FILTER.**
6. Wipe the mounting base for the Oil Filter with a clean cloth.
7. Apply a thin coat of clean motor oil to the new Oil Filter Gasket. **DO NOT USE GREASE OR USED OIL.**
8. Line up the threads carefully to avoid cross threading and screw the new Oil Filter on until the Filter Gasket contacts the base, and then tighten the Oil Filter 3/4 to 1 turn. **DO NOT OVER TIGHTEN.**
9. Mount the Oil Drain Hose Assembly onto the Bracket and replace the Oil Fill Cap.
10. Refill the oil by following the instructions in Chapter 2.

**Note:** Be sure to use environmentally safe disposal procedures in the disposing of the used oil.

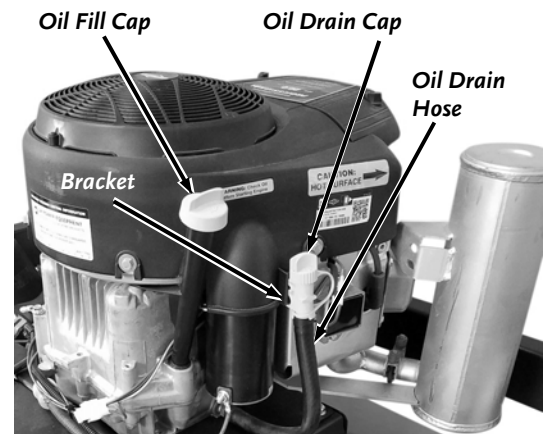

**Figure 36**



**Figure 37**

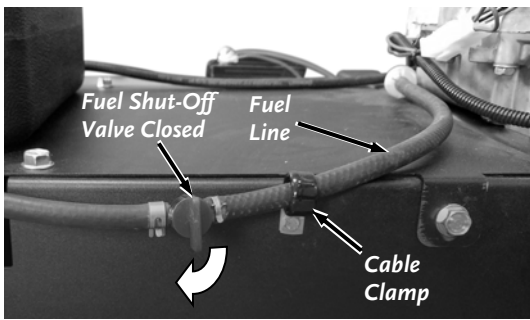

Figure 38

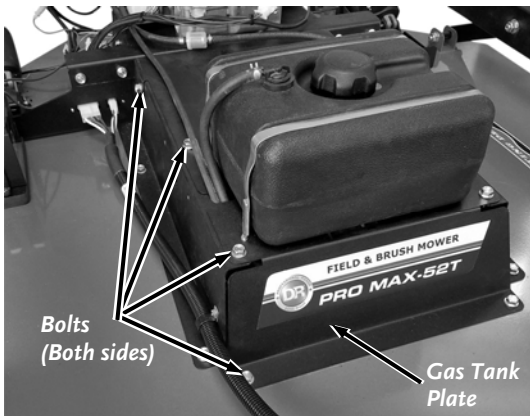

Figure 39

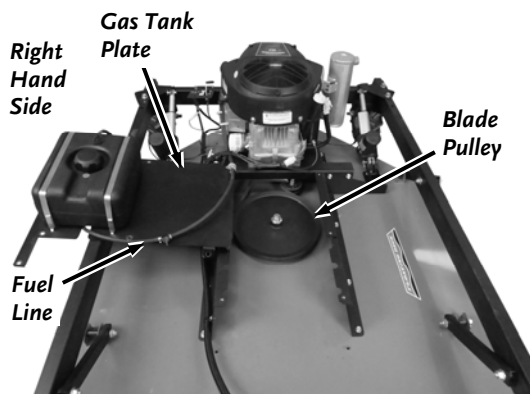

Figure 40

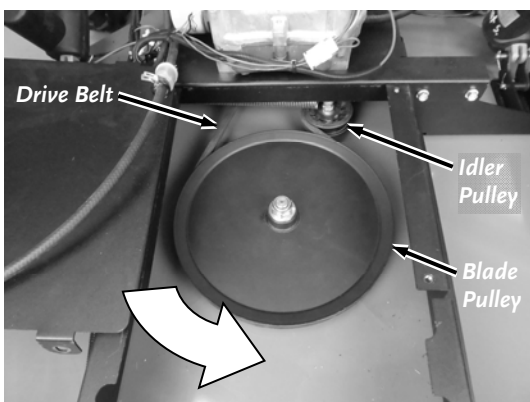

Figure 41

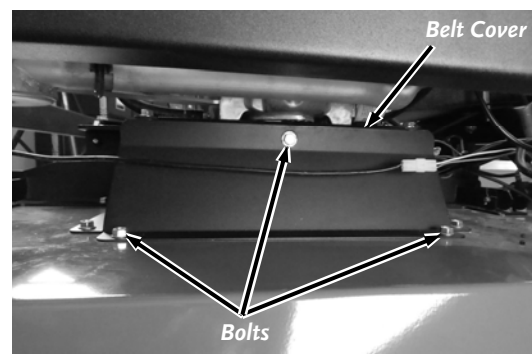

Figure 42

## Removing and Replacing the Drive Belt

### Tools Needed:

- 5/16" Socket w/Ratchet
- 9/16" Wrench
- Pry Bar or long Screwdriver
- Gloves

### NOTICE

Use only DR belts on your machine. They have been thoroughly tested and proven for many hours of use.

### Removing the Belt

1. Turn the Fuel Shut-Off Valve to the Closed position (**Figure 38**).
2. Remove the Screw that secures the Fuel Line Cable Clamp Using a 5/16" Socket w/Ratchet.
3. Remove the eight bolts securing the Gas Tank Plate using a 9/16" Wrench (**Figure 39**).
4. Ensure that the Gas Tank Cap is tight.

### NOTICE

When moving the Gas Tank Plate, be careful not to stress the Fuel Lines because it could damage the Fuel Lines or Connections.

5. Carefully lift the Gas Tank Plate and position it on the right hand side of the machine (**Figure 40**). Leave enough space to access the Blade Pulley.
6. Rotate the Blade Pulley Counter Clockwise as you roll the Drive Belt up and over the Blade Pulley (**Figure 41**).

**Note:** It works best to roll the Belt off and onto the Blade Pulley on the opposite side of the Idler Pulley.

7. Rotate the Idler Pulley away from the Blade Pulley as you pull the Belt up and away from the Pulleys.
8. At the back of the machine, use a 9/16" Wrench to remove the three Bolts securing the Belt Cover and set the Belt Cover aside (**Figure 42**).

- Rotate the Idler Pulley away from the Drive Belt using a Pry Bar or Long Screwdriver and pull the Drive Belt down off the Clutch Pulley (**Figure 43**).
- Pull the Drive Belt out from the back of the machine.

### **Installing the Belt**

- From the back of the machine, insert the new Drive Belt under the Clutch Pulley until one end is over the Blade Pulley up front and the other end is near the Clutch Pulley (**Figure 43**).
- Rotate the Idler Pulley away from the Clutch Pulley using a Pry Bar or Long Screwdriver and position the Drive Belt onto the Clutch Pulley.
- From the front of the machine, rotate the Idler Pulley away from the Blade Pulley as you position the Belt between the two Pulleys (**Figure 44**).
- Insert the Drive Belt "V" into the Blade Pulley Groove on the left side of the machine. Rotate the Blade Pulley Clockwise until the Drive Belt slides fully into the Pulley groove.
- Perform a final check to ensure that the belt is installed properly into the Clutch Pulley, Idler Pulley, and Blade Pulley.
- Reinstall the Belt Cover at the back of the machine.
- Reinstall the Gas Tank Plate making sure that the Fuel Line, Vapor Lines, and Wire Harness do not get pinched under the Plate.

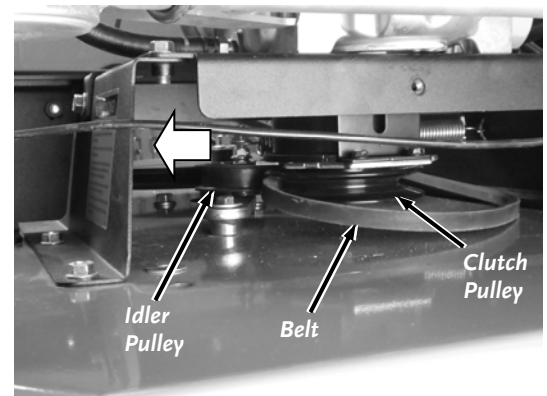

**Figure 43**

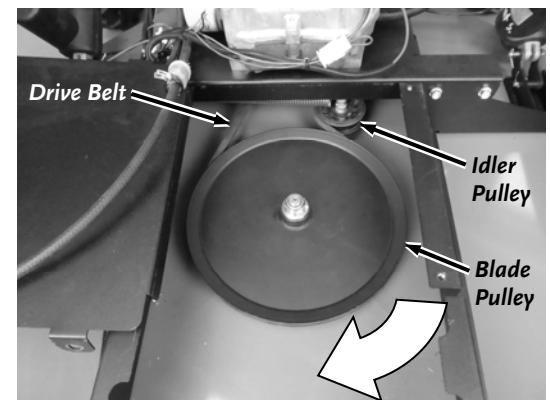

**Figure 44**

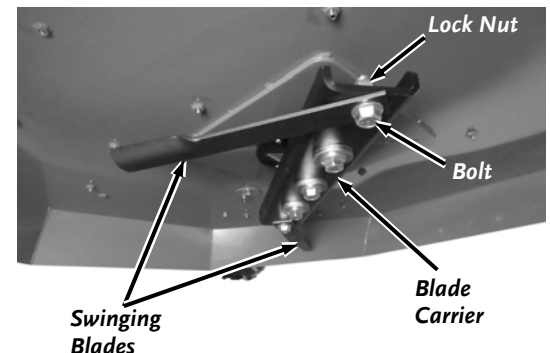

**Figure 45**

### **NOTICE**

When positioning the Gas Tank Plate be careful not to stretch the Fuel and Vapor Lines. Ensure that the Fuel and Vapor Lines as well as the Wire Harness are not pinched under the Gas Tank Plate.

- Reinstall the Cable Clamp that secures the Fuel Line.

### **Removing and Replacing the Swinging Blades**

**Note:** Replace the Blade(s) when worn or damaged.

#### **Tools and Supplies needed:**

- Two 1-1/8" Wrenches
- Gloves

### **! WARNING**

Wear gloves and use caution when pushing or pulling the wrench next to the blade. If the wrench slips off the bolt you may be seriously injured.

- Disconnect the Tow Behind DR Field and Brush Mower from the Tow Vehicle.
- Lift and support the front of the Mower off the Ground using a Jack and Jack Stands. Chock the rear wheels to prevent them from moving.
- Remove the Bolt and Lock Nut securing the Swinging Blade to the Blade Carrier using two 1-1/8" Wrenches and remove the Blade. (**Figure 45**).
- Position the new or sharpened Swinging Blade under the Blade Carrier. Push the Bolt up From the Bottom and secure on top with the Locknut.
- Using two 1-1/8" Wrenches, tighten the Locknut until it touches the Blade Carrier to allow for the Blade Swinging action.

**Note:** If the Blade does not swing freely after tightening, loosen the Locknut about 1/4 to 1/2 turn.

- Repeat steps 3 through 5 for the other Swinging Blade.

## Replacing the Carbon Canister

### Tools needed:

- Wire Cutters
- Pliers

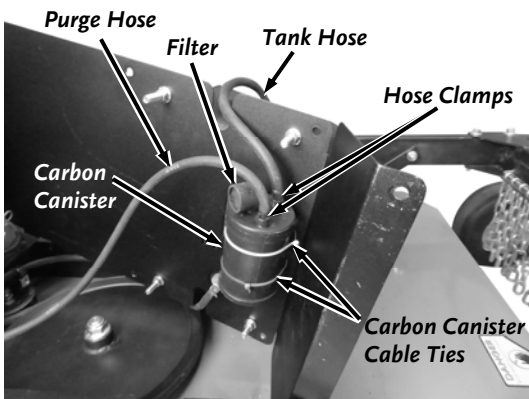

Figure 46

1. Remove the Gas Tank Plate as described in steps 1 through 5 on page 22 of the “Removing and Replacing the Drive Belt” section.
2. Cut the Cable Ties that are securing the Carbon Canister to the Gas Tank Plate using Wire Cutters (**Figure 46**).
3. Remove the rubber Filter Elbow for better access to the Hoses.
4. Slide the Hose Clamps away from the Hose connections using Pliers and twist as you pull the Hoses from the Canister.
5. Install the Hoses onto the new Carbon Canister and position the Hose Clamps onto the ends with Pliers.

**Note:** The Hoses **MUST** be installed onto the new Canister in the same location as they were on the old Canister. The Canister is labeled “Purge” (this hose is from the engine) and “Tank” (this hose is from the top of the fuel tank).

6. Slide new Cable Ties through the Canister Brackets and position the Canister onto the Brackets. Make sure the Filter is installed and facing in a direction that will be pointing down when the Tank Plate is reinstalled (the filter can be rotated if needed).
7. Tighten the Cable Clamps around the Canister and cut the excess with Wire Cutters.
8. Reinstall the Gas Tank Plate and Fuel Line Clamp. Turn the Fuel Shut-Off Valve to the Open position.



## Battery Care

Proper care can extend the life of a Battery. Follow these recommendations to ensure your Battery's best performance and long life:

- Do not allow the Battery charge to get too low. If the machine is not used, charge the Battery every 4 – 6 weeks. Operate the Engine for at least 45 minutes to maintain proper Battery charge.
- Store an unused Battery in a dry area that does not freeze.
- Do not charge an already charged Battery. In theory, you cannot overcharge our Battery with a trickle Charger; however, when a Battery is fully charged and the Charger is still on, it generates heat that could be harmful to the Battery. A fully charged Battery will read 12V-13.2V with a Voltmeter.
- Do not continue to crank the Engine when the Battery charge is low.

## Disposing of the Battery Responsibly

The Battery is a sealed lead-acid Battery. Recycle or dispose of it in an environmentally sound way.

- Do not dispose of a lead-acid Battery in a fire; the Battery may explode or leak.
- Do not dispose of a lead-acid Battery in your regular, household trash. Laws in most areas prohibit incinerating, disposing in a landfill, or mixing a sealed lead-acid Battery with household trash.

## Charging the Battery

Operate the Mower Engine for at least 45 minutes to maintain proper Battery charge. If the Battery loses its charge, you'll need to use a trickle Charger (like the DR Battery Charger) to recharge it. The Charger should have an output of 12 volts at no more than 2 amps.

**Note:** *The charging system of a running engine is designed to maintain a battery's present charge. Starting a machine that has a significantly discharged or dead Battery using the Recoil Starter or Jumper Cables will not recharge the Battery.*

To connect a Battery Charger to your TOW BEHIND DR FIELD and BRUSH MOWER, follow the steps listed below.

1. Detach the two Battery wires going to the Battery on your Mower.
2. Attach the black (-) Battery Charger wire to the Battery negative (-) terminal, and attach the red (+) Battery Charger wire to the Battery positive (+) terminal.
3. Plug the Battery Charger into an outlet.
4. Charge until Battery Charger indicates that it is charged or Battery measures to 12-14V
  - At 1 amp, you may have to charge the Battery for as long as 24 hours.
  - At 2 amps, you may have to charge the Battery for as long as 12 hours.
5. Once Charged, disconnect Charger from outlet
6. Disconnect Battery from the Charger.
7. Reconnect the Battery Wires.

## Recycling a Used Battery

---

### NOTICE

Please dispose of used batteries responsibly, according to your local hazardous materials regulations. Never throw away used batteries in your household trash.

---

Please dispose of your used Batteries responsibly by recycling them. Call your local Solid Waste Management District or your local waste handler to locate the collection site nearest you. Some collection sites recycle Batteries year-round; others collect them periodically.

Visit these sites for more information:

- Web site of Earth 911 [[www.earth911.com](http://www.earth911.com)]
- International Metals Reclamation Company [[www.inmetco.com](http://www.inmetco.com)]
- Battery Council International [[www.batterycouncil.org](http://www.batterycouncil.org)]
- Environmental Protection Agency [[www.epa.gov](http://www.epa.gov)]

## Chapter 5: Troubleshooting

Most problems are easy to fix. Consult the Troubleshooting Table below for common problems and their solutions. If you continue to experience problems, contact us at [www.DRpower.com](http://www.DRpower.com) or call toll-free 1-800-DR-OWNER (376-9637) for support.

### WARNING

When performing any adjustment or maintenance, you must first shut off the engine, wait five (5) minutes to allow parts to cool and disconnect the spark plug wires, keeping them away from the spark plugs.

### Troubleshooting Table

| SYMPTOM  | POSSIBLE CAUSE   |
|--|--|
| <p><i>The Engine will not start.</i></p> <p><i>(Please refer to the Engine Owner's Manual for Engine-specific procedures.)</i></p>                         | <ul style="list-style-type: none"> <li>⇒ Check all the items under the section called "Starting" in Chapter 3.</li> <li>⇒ Check that the Blade Switch Safety Cover is DOWN in the Disengaged position.</li> <li>⇒ Make sure the Spark Plug wires are attached.</li> <li>⇒ If the Engine is cold, make sure the Throttle is in the CHOKE position. See "Starting" in Chapter 3.</li> <li>⇒ The gas must be fresh and clean. If the gas is old, change it. Use a fuel stabilizer if you keep gas longer than one month.</li> <li>⇒ The Spark Plugs may be dirty or cracked, change them.</li> <li>⇒ If the Spark Plugs are oily, leave them out, hold a rag over the Plug holes and crank the Engine over a couple of times using the Electric Starter to blow out any oil in the Cylinders, then wipe off the Plugs and reinsert them.</li> <li>⇒ The Air Filter may be dirty, change it following the procedure in the Engine Owner's Manual.</li> <li>⇒ There are two Fuses in the Wiring Harness. Check the Fuses and replace if needed.</li> <li>⇒ Check the wire connections—especially the ground connection, the large green Wire coming from the Battery, where it connects to the Channel Support.</li> <li>⇒ The Battery may not be charged. Check the voltage yourself or at a service station. If it is low, charge it with a 12-volt, 1 to 2-amp trickle charger. If you do not use your machine for at least 45 minutes at a time, the Battery may need to be periodically charged. See the "Battery Care" section in Chapter 4.</li> <li>⇒ If the Battery is charged and the DR TOW-BEHIND FIELD &amp; BRUSH MOWER still will not start, visit our website at <a href="http://www.DRpower.com">www.DRpower.com</a>.</li> </ul> |
| <p><i>The Engine lacks power or is not running smoothly.</i></p> <p><i>(Please refer to the Engine Owner's Manual for Engine-specific procedures.)</i></p> | <ul style="list-style-type: none"> <li>⇒ The Throttle Lever may be in the wrong position; Make sure the Throttle Lever is in the RUN position.</li> <li>⇒ The Air Filter may be dirty, change it following the procedure in the Engine Owner's Manual.</li> <li>⇒ The Spark Plugs may be dirty or cracked, change them.</li> <li>⇒ If the Spark Plugs are oily, leave them out, hold a rag over the Plug holes and crank the Engine over a couple of times using the Electric Starter to blow out any oil in the Cylinders, then wipe off the Plugs and reinsert them.</li> <li>⇒ The gas must be fresh and clean. If the gas is old, change it. Use a fuel stabilizer if you keep gas longer than one month.</li> <li>⇒ The Engine may not have the right amount of clean oil. If it is dirty, change it following the procedure in Chapter 4.</li> <li>⇒ If the Engine still lacks power, visit our website at <a href="http://www.DRPower.com">www.DRPower.com</a>.</li> </ul>  |

**! WARNING**

When performing any adjustment or maintenance, you must first shut off the engine, wait five (5) minutes to allow parts to cool and disconnect the spark plug wires, keeping them away from the spark plugs.

**Troubleshooting Table (Continued)**

| <b>SYMPTOM</b>                                      | <b>POSSIBLE CAUSE</b>  |
|---|--|
| <i>Engine smokes.</i>                               | <ul style="list-style-type: none"> <li>⇒ Check the oil level and adjust as needed.</li> <li>⇒ You may be operating the machine on too great an incline. See “Slopes and Uneven Terrain” in Chapter 3</li> <li>⇒ Check the Air Filter and clean or replace if needed.</li> <li>⇒ You may be using the wrong oil—too light for the temperature. Refer to your Engine Owner’s Manual for detailed information.</li> <li>⇒ Clean the Cooling Fins and the Carburetor housing if they are dirty.</li> <li>⇒ If the Engine still smokes, visit our website at <a href="http://www.DRPower.com">www.DRPower.com</a> for assistance</li> </ul>   |
| <i>The Belt frays or rolls over the Pulley.</i>     | <ul style="list-style-type: none"> <li>⇒ There may be a nick in a Pulley groove. Check the Belt for wear and hard spots. File off any nicks on the Pulley.</li> <li>⇒ The Belt may be stretched; replace it. See Chapter 4.</li> </ul>   |
| <i>Blades vibrate when engaged.</i>                 | <ul style="list-style-type: none"> <li>⇒ The Blade Carrier Mounting Bolt may not be tight enough. Tighten the Bolt as tight as possible by hand with at least a 1ft long 1-1/8" Wrench.</li> <li>⇒ A Swinging Blade may be too loose on the Blade Carrier. Re-tighten the Swinging Blade mounting hardware. See Chapter 4. Be sure to turn OFF the Engine and remove the Spark Plug wire(s) before performing this operation.</li> <li>⇒ Replace a Swinging Blade if it is chipped, bent, or broken.</li> <li>⇒ The Spindle Bearings may be damaged or the Spindle Shaft is bent.</li> <li>⇒ If the Blades still vibrate, visit our website at <a href="http://www.DRpower.com">www.DRpower.com</a> for assistance.</li> </ul> |
| <i>The Blades are not cutting or are loose.</i>     | <ul style="list-style-type: none"> <li>⇒ The Blade Carrier Mounting Bolt may not be tight enough. Tighten the Bolt as tight as possible by hand with at least a 1ft long 1-1/8" Wrench.</li> <li>⇒ A Swinging Blade may be too loose on the Blade Carrier. Re-tighten the Swinging Blade mounting hardware. See Chapter 4. Be sure to turn OFF the Engine and remove the Spark Plug wire(s) before performing this operation.</li> <li>⇒ Sharpen the Swinging Blades; they may be dull or nicked.</li> </ul>   |
| <i>The Blades will not Engage and/or Disengage.</i> | <ul style="list-style-type: none"> <li>⇒ Faulty Blade Control Switch. Remove and replace the Switch on the Remote Control.</li> <li>⇒ Faulty/Blown Fuse. Remove and inspect fuses, replace if necessary.</li> <li>⇒ Faulty Electric Clutch. Visit our website at <a href="http://www.DRpower.com">www.DRpower.com</a> for assistance.</li> <li>⇒ Low or weak battery may cause electric clutch to not engage. Check battery for sufficient voltage.</li> </ul>   |
| <i>The Mower Deck Will Not Raise or Lower</i>       | <ul style="list-style-type: none"> <li>⇒ Faulty Blade Control Switch. Remove and replace the Switch on the Remote Control.</li> <li>⇒ Faulty Actuator. Visit our website at <a href="http://www.DRpower.com">www.DRpower.com</a> for assistance.</li> <li>⇒ Low or weak Battery may cause the Actuator not to function. Check Battery for sufficient voltage.</li> </ul>   |
| <i>Excessive Engine stalling.</i>                   | <ul style="list-style-type: none"> <li>⇒ The brush or grass is too heavy at the current cutting height or at the current Tow Vehicle speed. Raise the cutting height and drive slower when cutting.</li> </ul>   |

## Chapter 6: Parts Lists and Schematic Diagrams

### Parts List – Frame and Tow Bar

**Note:** Part numbers listed are available through DR Power Equipment.

| <u>Ref#</u> | <u>Part#</u> | <u>Description</u>                                | <u>Ref#</u> | <u>Part#</u> | <u>Description</u>                             |
|-------------|--------------|---|-------------|--------------|--|
| 1           | 33338        | Nut, Nylon Lock, Flanged, 3/4-10                  | 22          | 39501        | Rod, Retention, Chain Guard                    |
| 2           | 35281        | Bolt, Hex Flange, Tri Lobe, 3/8-16 X 3/4" GR5 ZP  | 23          | 39718        | Guard, Push Bar                                |
| 3           | 39711        | Support, Wheels                                   | 24          | 35495        | Bracket, Offset                                |
| 4           | 39509        | Push Bar  | 25          | 18737        | Pin, Clevis, 1/2" OD X 4.5" Lg                 |
| 5           | 39710        | Push Bar, Rear                                    | 26          | 16003        | Pin, Hair, 1/2" To 9/16", .12" Wire            |
| 6           | 36573        | Bolt, Hex, Flange, 1/2-13 X 4.5", GR5, ZP         | 27          | 35496        | Bar, Tow                                       |
| 7           | 33335        | Nut, Nylon Lock, Flanged, 1/2-13                  | 28          | 23499        | Washer, SAE Flat, 1/2", ZP                     |
| 8           | 36289        | Bushing, Sway Brace                               | 29          | 25549        | Pin, Clevis, 1/2" X 2 1/2", TRT                |
| 9           | 36572        | Bolt, Hex, Flange, 1/2-13 X 3.5", GR5, ZP         | 30          | 34511        | Bolt, Hex, Flange, 1/2-13 X 3", GR5, ZP        |
| 10          | 35494        | Brace, Sway                                       | 31          | 10000031528  | Clamp, Loop, Cushioned, 3/4" ID, 1-13/16" Long |
| 11          | 35498        | Caster, Front                                     | 32          | 35497        | Extension, Tow Bar                             |
| 12          | 18655        | Pin, Cotter, 3/16" X 2"                           | 33          | 15720        | Key, Ignition Switch                           |
| 13          | 35481        | Wheel, 11 X 4-5, Flat Free, Smooth Tread          | 34          | 15049        | Screw, 8-32 X 1/2"                             |
| 14          | 34324        | Bolt, HCS, 3/4-10 X 7", ZP                        | 35          | 39735        | Pin, Actuator, 40mm                            |
| 15          | 35482        | Wheel, 13 X 5-6, Lug Tread                        | 36          | 36582        | Label, Height Adjust, Left                     |
| 16          | 36548        | Control Panel                                     | 37          | 36581        | Label, Height Adjust, Right                    |
| 17          | 11170        | Screw, 10-32 X 1/2", Type F, Hex, ZP              | 38          | 24648        | Receiver, 2", Class II                         |
| 18          | 10000029087  | Cable, Throttle, 14"                              | 39          | 33349        | Bolt, Hex Flange, 1/2-13 x 5", GR8, ZP         |
| 19          | 22223        | Switch, Snap In, e/s                              | 40          | 25312        | Chains, Safety, 36", Individual                |
| 20          | 39500        | Bracket, Chain Guard                              | 41          | 33443        | Link, Chain, 9/16" ID, 1/4" TH                 |
| 21          | 36317        | Chain, Welded, 1/4", Grade 30 Proof Coil, 8 Links |             |              |  |

**Schematic – Frame and Tow Bar**

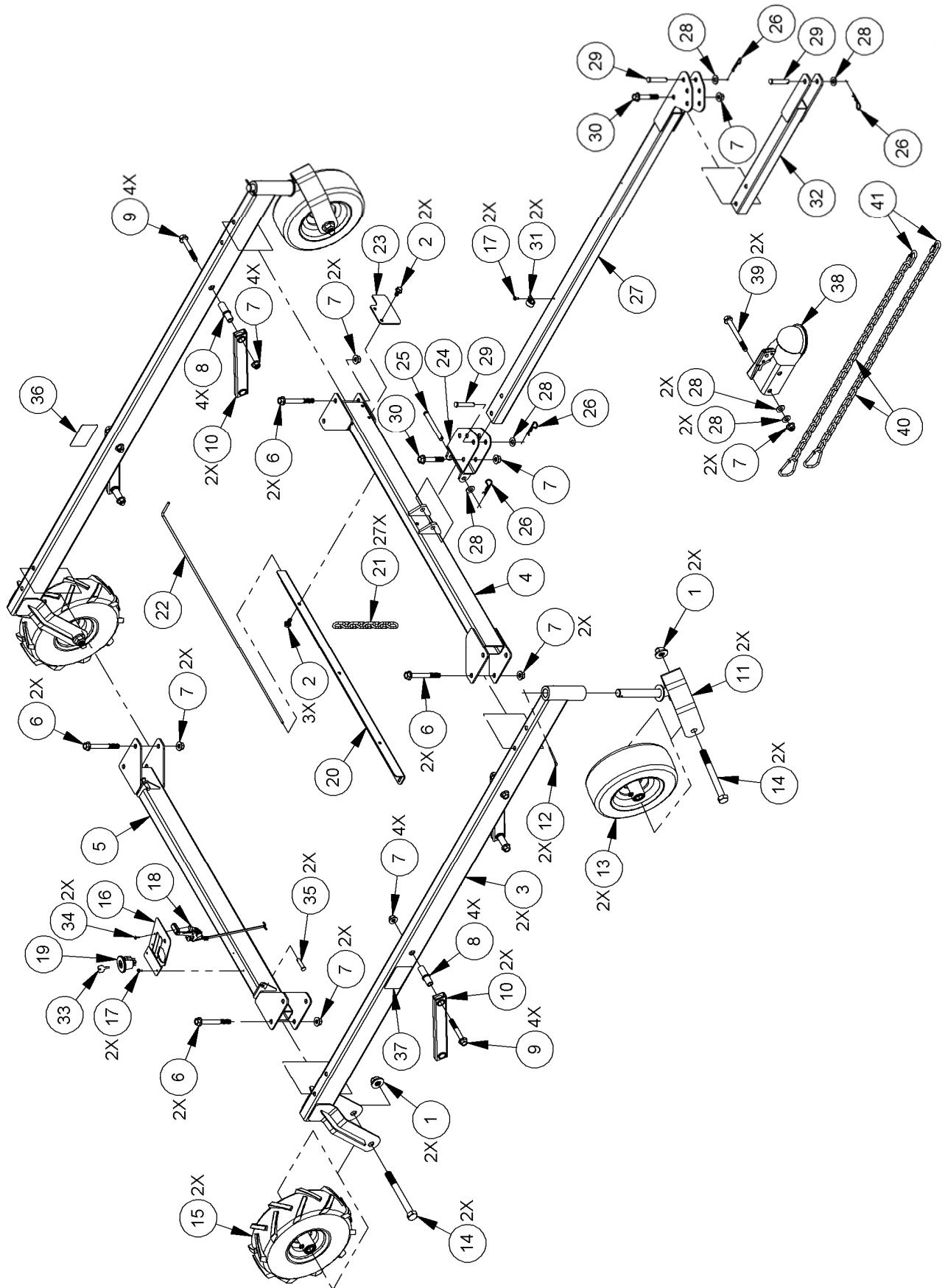

## Parts List – Deck Assembly

**Note:** Part numbers listed are available through DR Power Equipment.

| <u>Ref#</u> | <u>Part#</u> | <u>Description</u>                                | <u>Ref#</u> | <u>Part#</u> | <u>Description</u>   |
|-------------|--------------|---|-------------|--------------|--|
| 1           | 39149        | Deck, Brush, 52"                                  | 20          | 36555        | Spring, 1" OD, 8" L, .105" Wire  |
| 2           | 36259        | Spindle Assembly, Brush                           | 21          | 39713        | Channel, Support, Left   |
| 3           | 39257        | Carrier, Blade                                    | 22          | 39712        | Channel, Support, Right  |
| 4           | 36564        | Bolt, Hex, Flange, 3/4-10 X 1.75", GR8, ZP        | 23          | 36255        | Cover, Belt  |
| 5           | 36307        | Washer, Blade                                     | 24          | 11170        | Screw, 10-32 X 1/2", Type F, Hex, ZP                                   |
| 6           | 33338        | Nut, Nylon Lock, Flanged, 3/4-10                  | 25          | 39504        | Actuator   |
| 7           | 35483        | Blade, Swinging, Air Tip                          | 26          | 39707        | Link, Lift System  |
| 8           | 37382        | Idler Arm   | 27          | 39513        | Spacer, Lift System  |
| 9           | 11239        | Washer, Flat, 3/8", USS                           | 28          | 39706        | Mount, Molex   |
| 10          | 15712        | Bolt, HCS FT, 3/8-16 X 2-1/4", GR5, ZP            | 29          | 10000031528  | Clamp, Loop, Cushioned, 3/4" ID, 1-13/16" Long                         |
| 11          | 22253        | Washer, Lock, 3/8"                                | 30          | 35271        | Pulley, Idler, Flat, , 3.12" X .75" X .375" With 3/8" Shoulder Adapter |
| 12          | 33333        | Nut, Nylon Lock, Flanged, 3/8-16                  | 31          | 39733        | Pin, Actuator, 60mm  |
| 13          | 36258        | Bushing, .380" X .664" X .9"                      | 32          | 39734        | Pin, Actuator, 50mm  |
| 14          | 11465        | Bolt, HCS Ft, 3/8-16 X 3", GR5, ZP                | 33          | 18064        | Washer, 1.06" ID X 2" OD X .13", ZP                                    |
| 15          | 36563        | Bolt, Hex, Flange, 1/2-13 X 1.25", GR5, ZP        | 34          | 10000031667  | Label, Deck, Float   |
| 16          | 32237        | Key, Ansi #806 Woodruff, 1/4" X 3/4"              | 35          | 13649        | Label, Danger  |
| 17          | 39506        | Pulley, 13" OD, 1" Bore, 1/4" Key, B              | 36          | 37122        | Label, Warnings  |
| 18          | 39730        | Rail, Support, 3/8" Strps                         | 37          | 36261        | Cap, Spindle   |
| 19          | 35281        | Bolt, Hex, Flange, Tri Lobe, 3/8-16 X 3/4" GR5 ZP |             |              |  |

**Schematic – Deck Assembly**

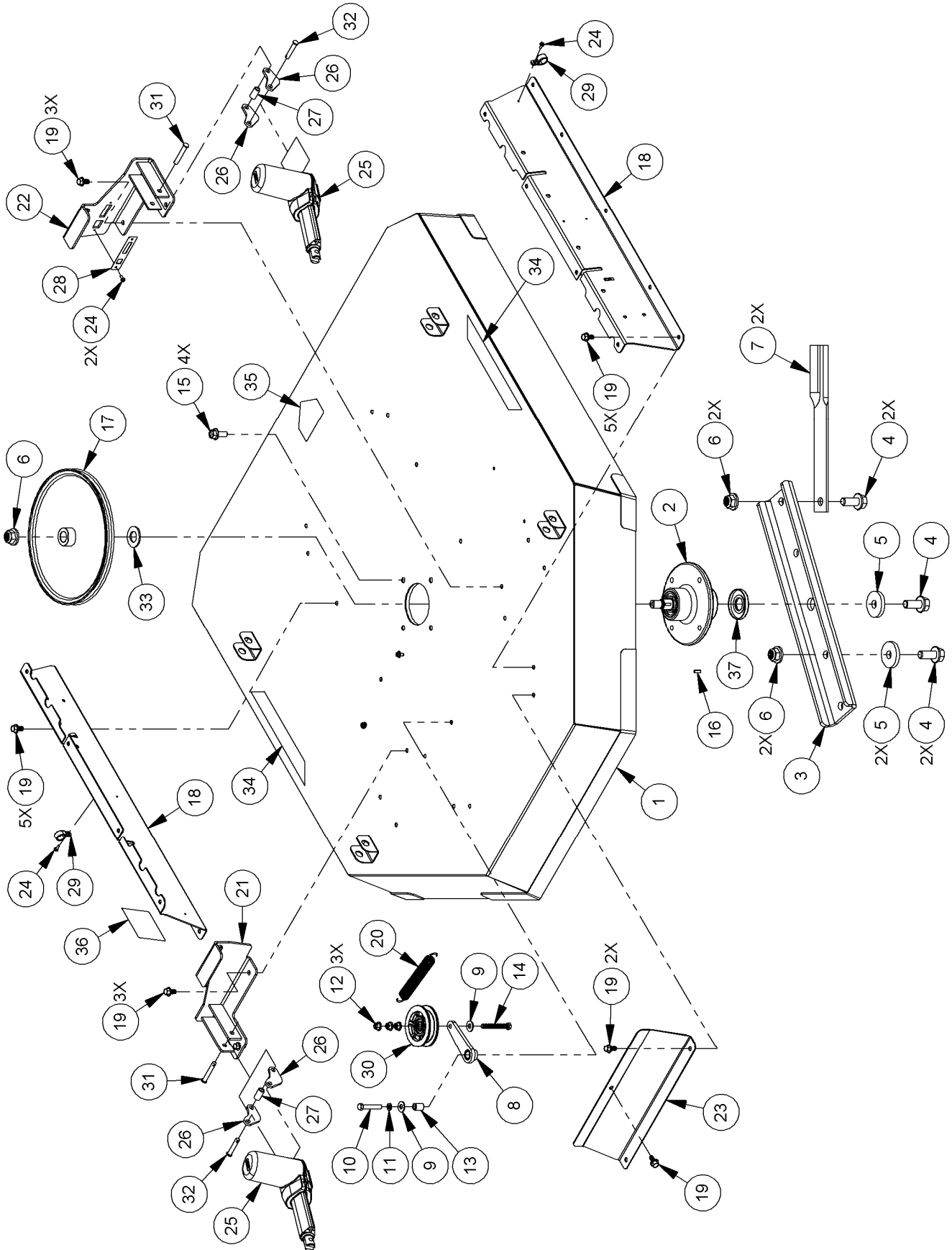

## Parts List – Drive Assembly

**Note:** Part numbers listed are available through DR Power Equipment.

| <u>Ref#</u> | <u>Part#</u> | <u>Description</u>                              | <u>Ref#</u> | <u>Part#</u> | <u>Description</u>   |
|-------------|--------------|---|-------------|--------------|--|
| 1           | 33333        | Nut, Nylon Lock, Flanged, 3/8-16                | 28          | 39520        | Wire Harness, Machine, TB52                                |
| 2           | 35281        | Bolt-Hex Flange Tri Lobe 3/8-16 X 3/4" GR5 ZP   | 29          | 31117        | Screw, HWH, 1/4-20 X 3/4, Taptite                          |
| 3           | 38581        | Strap, Tank, 3/8-16 Studs                       | 30          | 11073        | Nut, Nylon Lock, 1/4-20, ZP                                |
| 4           | 12797        | Cable Tie, 17", # 50                            | 31          | 17912        | Screw, 1/4-20 X .500", Tri-Lobe (Harness Ground to Engine) |
| 5           | 38530        | Carbon Cannister, 300cc, 1/4" Tank, 3/16" Purge | 32          | 31283        | Nut, Lock, 1/4-20, Serrated Flange (Located on Starter)    |
| 6           | 21166        | Hose, fuel, 1/4" ID, CE Cert                    | 33          | 22252        | Washer, Split Lock, 7/16", GR8                             |
| 7           | 26580        | Hose, Vapor, 3/16" ID                           | 34          | 11250        | Washer, Lock, 1/4" External Tooth                          |
| 8           | 10066        | Clamp, Fuel Line                                | 35          | 34275        | Wire, Battery Ground                                       |
| 9           | 39516        | Cover, Control Box                              | 36          | 13447        | Battery, 12V, 9Ah  |
| 10          | 39507        | Belt, B53                                       | 37          | 10000024617  | Screw, Sheet Metal   |
| 11          | 19130        | Washer, Flat, .469" X 1.62" X .25"              | 38          | 10000030628  | Pad, Battery, Foam   |
| 12          | 22142        | Spacer, 1.00" ID X 1.75" OD X 1.25"             | 39          | 10000032859  | Plate, Battery Pad   |
| 13          | 22214        | Bolt, 7/16-20 X 2-1/4", GR8, ZP                 | 40          | 10145        | Bolt, HCS, 1/4-20 X 1-1/2", GR5, ZP                        |
| 14          | 39729        | Mount, Motor                                    | 41          | 13758        | Label, Check Oil, 2.75" X .63"                             |
| 15          | 24230        | Strap, Battery                                  | 42          | 13683        | Label, Caution, Hot Surface                                |
| 16          | 34132        | Manifold, Exhaust, Briggs, 20HP V-Twin          | 43          | 36584        | Label, Blade Engage  |
| 17          | 34131        | Muffler, Exhaust, Briggs, 20HP V-Twin           | 44          | 38913        | Label, Raise/Lower   |
| 18          | 36286        | Valve, Fuel Shutoff                             | 45          | 36304        | Switch, Toggle   |
| 19          | 39519        | Wire Harness, Actuators                         | 46          | 36657        | Switch, Rocker   |
| 20          | 37050        | Clutch, Ogura, GT1.5A-GR02                      | 47          | 39518        | Wire Harness, Tether, 52"                                  |
| 21          | 38535        | Fuel Tank Assy, 2.5 Gal, Kelch Valve            | 48          | 39515        | Box, Control   |
| 22          | 39709        | Engine, 20HP, V-Twin, Pro, B&S                  | 49          | 36305        | Safety Cover, Toggle Switch                                |
| 23          | 34130        | Gasket, Exhaust, Briggs, 20HP V-Twin            | 50          | 10000031697  | Label, Branding, TB52                                      |
| 24          | 35056        | Bolt, Muffler, B&S, 20HP                        | 51          | 36551        | Wire Harness, Hand Control                                 |
| 25          | 27960        | Clamp, Exhaust, 1.25"                           | 52          | 39731        | Plate, Gas Tank  |
| 26          | 15045        | Bolt, HCS, 5/16-18 X 1-3/4", GR5, ZP            | 53          | 26581        | Clamp, Vapor Hose  |
| 27          | 33332        | Nut, Nylon Lock, Flanged, 5/16-18               |             |              |  |







# TOW-BEHIND DR<sup>®</sup> FIELD and BRUSH MOWER



## 2-Year Limited Warranty Terms and Conditions

The TOW-BEHIND DR<sup>®</sup> FIELD and BRUSH MOWER is warranted for two (2) years against defects in materials or workmanship when put to ordinary and normal consumer use; ninety (90) days for any other use.

For the purposes of all the above warranties, "ordinary and normal consumer use" refers to non-commercial residential use and does not include misuse, accidents, or damage due to inadequate maintenance.

DR Power Equipment certifies that the DR<sup>®</sup> FIELD and BRUSH MOWER is fit for ordinary purposes for which a product of this type is used. DR Power Equipment however, limits the implied warranties of merchantability and fitness in duration to a period of two (2) years in consumer use, ninety (90) days for any other use except all emission related components. DR Power Equipment limits the implied warranties of merchantability and fitness in duration to a period of two (2) years for all emissions related components. The Engine manufacturer warrants the Engine separately. The Battery is warranted for one (1) year.

The 2-Year Limited Warranty on the TOW-BEHIND DR<sup>®</sup> FIELD and BRUSH MOWER starts on the date the machine ships from our factory. The 2-Year Limited Warranty is applicable only to the original owner.

The warranty holder is responsible for the performance of the required maintenance as defined by the manufacturer's owner's manuals. The warranty holder is responsible for replacement of normally wearing parts such as the Drive Belts, Blades, Battery, Spark Plugs and Filters (Air and Oil). This warranty does not cover attachments and accessories to the machine.

During the warranty period, the warranty holder is responsible for the machine transportation charges, if required.

During the warranty period, warranty parts will ship by standard method at no charge to the warranty holder.

Expedited shipping of warranty parts is the responsibility of the warranty holder.

**SOME STATES DO NOT ALLOW LIMITATIONS ON THE LENGTH OF IMPLIED WARRANTIES, SO THE ABOVE LIMITATIONS MAY NOT APPLY TO YOU.**

DR<sup>®</sup> Power Equipment shall not be liable under any circumstances for any incidental or consequential damages or expenses of any kind, including, but not limited to, cost of equipment rentals, loss of profit, or cost of hiring services to perform tasks normally performed by the TOW-BEHIND DR<sup>®</sup> FIELD and BRUSH MOWER.

**SOME STATES DO NOT ALLOW THE EXCLUSION OR LIMITATION OF INCIDENTAL OR CONSEQUENTIAL DAMAGES, SO THE ABOVE LIMITATIONS MAY NOT APPLY TO YOU.**

**THIS WARRANTY GIVES YOU SPECIFIC LEGAL RIGHTS, AND YOU HAVE OTHER RIGHTS, WHICH VARY FROM STATE TO STATE.**

## Daily Checklist for the TOW-BEHIND DR FIELD and BRUSH MOWER

To help maintain your TOW-BEHIND DR FIELD and BRUSH MOWER for optimum performance, we recommend you follow this checklist each time you use your machine.

---

### WARNING

When performing any adjustment or maintenance, you must first shut off the engine, wait five (5) minutes to allow parts to cool and disconnect the spark plug wires, keeping them away from the spark plugs.

---

- Check the engine oil and Gas Tank level.
- Check that Engine is clean of debris.
- Check the general condition of the Mower, e.g.; nuts, bolts, welds, etc.
- Check Tire Pressure and wear.
- Check the Frame for wear and damage.
- Check the Blades and Spindle for tightness, nicks, cracks, wear or debris that has wrapped around.
- Check that the Remote Control is secure.

### End of Season and Storage

---

### WARNING

When performing any adjustment or maintenance, you must first shut off the engine, wait five (5) minutes to allow parts to cool and disconnect the spark plug wire(s), keeping it away from the spark plug(s).

---

**Note:** Please refer to the Engine Owner's Manual for Engine-specific procedures.

- Change the Engine oil and Oil Filter and replace the Fuel Filter.
- Remove the Spark Plugs and pour about 1 ounce of motor oil into the Cylinder holes. Replace the Plugs and crank the Engine over a couple of times using the Electric Starter. This will coat the pistons and seat the valves to prevent moisture buildup.
- Clean or replace the Air Filter.
- Clean dirt and debris from the Cylinder Head Cooling Fins, Blower Housing, Debris Screen, and Muffler area of the Engine.
- If your TOW-BEHIND DR FIELD and BRUSH MOWER will be idle for more than 30 days, we recommend using a gas stabilizer. This will prevent sediment from gumming up the Carburetor. If there is dirt or moisture in the gas or tank, remove it by draining the tank. Completely fill the tank with fresh, unleaded gas and add the appropriate amount of stabilizer or gasoline additive. Run the Engine for a short time to allow the additive to circulate.
- Remove any wrapped weeds from the Blades Carrier Housing. Clean grass and debris from the top and underneath the mower Deck with a stiff brush.
- Check the Blades for nicks and wear. Remove the Blades and sharpen them, or have them professionally sharpened if needed.
- Touch-up all rusted or chipped paint surfaces. Sand them lightly before painting.
- Be sure all nuts, bolts, and screws are securely fastened.
- Inspect moving parts and the Blades' Drive Belt for damage and wear; replace if necessary.
- Store the Battery in a dry area that will not freeze. If you will not use the machine over a long period, charge the Battery every four to six weeks.
- If possible, store your TOW-BEHIND DR FIELD and BRUSH MOWER inside, but not near an open flame or spark such as found in a water heater.
- After the TOW-BEHIND DR FIELD and BRUSH MOWER has cooled, cover the machine with a suitable protective cover that does not retain moisture. Do not use plastic, as this material cannot breathe; it also allows condensation to form, which will cause your machine to rust.



---

75 MEIGS ROAD, P.O. BOX 25, VERGENNES, VERMONT 05491