

NOTE:

THE REVOLT SERIES BATTERY PACK IS NOT CHARGED OUT OF THE CARTON. BEFORE USING THE BATTERY PACK AND CHARGER, READ THE SAFETY INSTRUCTIONS ON THE BACK. THEN FOLLOW ASSEMBLY AND CHARGING PROCEDURES OUTLINED BELOW.

INCLUDED COMPONENTS



BATTERY PACK (1)
33-100512



BATTERY CHARGER (1)
33-100513

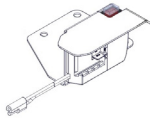

WEATHER SHIELD (1)
31-100502

TOOLS REQUIRED



PHILLIPS SCREWDRIVER

STEP 1

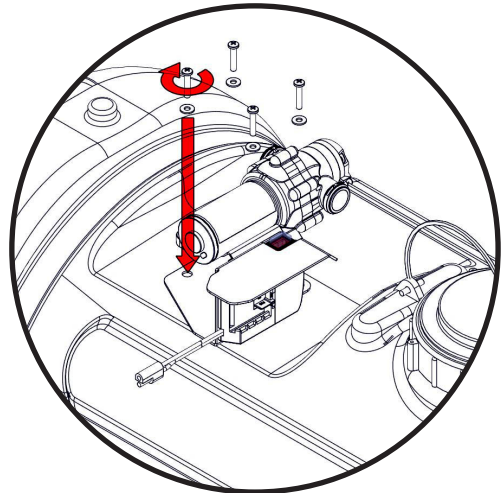

WITH A PHILLIPS SCREWDRIVER, REMOVE YOUR 12 VOLT PUMP FROM SPRAYER TANK.

LINEUP HOLES ON WEATHER SHIELD WITH SPRAYER TANK AND 12 VOLT PUMP.

MOUNT IN PLACE, UNDER THE PUMP, WITH EXISTING SCREWS.

STEP 2

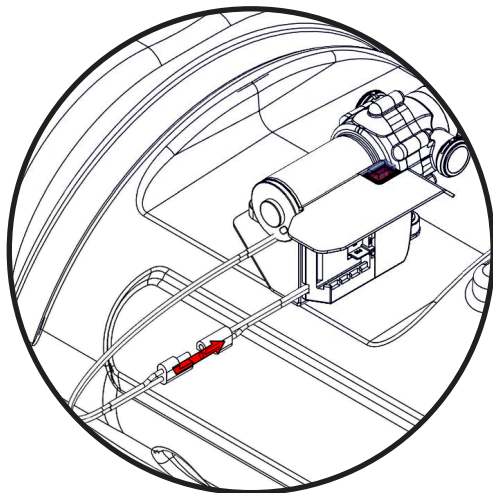

CONNECT THE WIRE HARNESS TO YOUR PUMP BY PUSHING THE TWO-PIN TERMINAL CONNECTORS TOGETHER.

REVOLT

RECHARGEABLE SPRAYER CONVERSION KIT

**ASSEMBLY GUIDE
& OPERATOR'S MANUAL**

WWW.MASTER-MFG.COM
320.340.6464

STEP 3

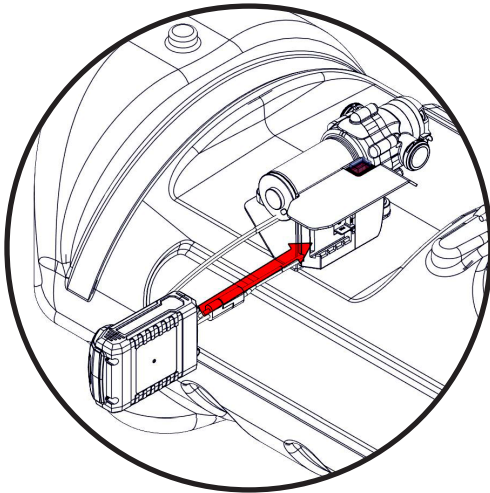

SLIDE BATTERY PACK INTO THE OPEN DOCK IN THE WEATHER GUARD. A CLICK WILL BE HEARD WHEN PROPERLY ATTACHED.

NOTE: TO RELEASE THE BATTERY PACK FROM THE WEATHER SHIELD DOCK, PRESS THE RELEASE BUTTON ON THE BACK OF THE BATTERY PACK.

STEP 4

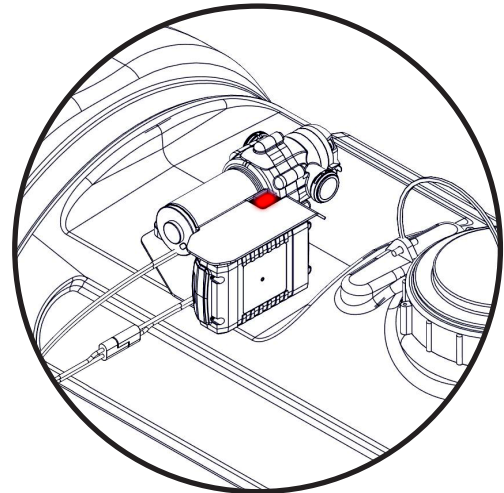

WHEN READY FOR SPRAYING, FLIP THE POWER SWITCH ON THE WEATHER SHIELD.

NOTE: THE POWER SWITCH WILL LIGHT UP IN THE ON POSITION, IF IT DOESN'T, THE BATTERY PACK WILL NEED TO BE FULLY CHARGED.

Charging Battery Pack

The REVOLT Series charger is designed to charge the Battery Pack in approximately 2 hours. This charger requires no adjustment and is designed to be as simple as possible to operate.

1. Connect Battery Charger to the open charge hole on top of the Battery Pack.
2. Plug the Battery Charger into an appropriate outlet.
3. The Battery Pack is fully charged when the Battery Charger light is **GREEN**.

WARNING READ AND UNDERSTAND ALL INSTRUCTIONS. Failure to follow all instructions listed below, may result in electric shock, fire and/or serious personal injury.

SAVE THESE INSTRUCTIONS – This manual contains important safety & operating instructions for the REVOLT Series charger.

1. **BEFORE USING THE BATTERY PACK AND CHARGER**, read this operator's manual, all labels on the battery pack, and your original sprayer manual.
2. **CAUTION:** To reduce risk of injury, **ONLY CHARGE REVOLT SERIES BATTERIES WITH REVOLT SERIES CHARGER**. Other types of batteries may burst causing personal injury and damage. Do not wire a battery pack to a power supply plug or the DC outlet of a vehicle. Batteries will be permanently disabled or damaged.
3. **AVOID DANGEROUS ENVIRONMENTS.** Do not charge battery pack in rain, snow, damp or wet locations. Do not use battery pack or charger in the presence of explosive atmosphere (gaseous fumes, dust or flammable materials) because sparks may be generated when inserting or removing battery pack, possibly causing fire.
4. **CHARGE IN A WELL VENTILATED AREA.** Do not allow smoking or open flames near charging battery pack. Vented gases may explode.
5. **DO NOT BURN OR INCINERATE BATTERY PACKS.** Battery packs may explode, causing personal injury or damage. Toxic fumes and materials are created when battery pack burns.
6. **DO NOT CRUSH, DROP OR DAMAGE** battery pack or charger. Do not use a battery pack or charger that has received a sharp blow, been dropped, run over, or damaged in any way.
7. **DO NOT DISASSEMBLE.** Incorrect reassembly may result in the risk of electric shock, fire or exposure to battery chemicals.
8. **BATTERY CHEMICALS CAUSE SERIOUS BURNS.** Never allow contact with skin, eyes, or mouth. If a damaged battery pack leaks battery chemicals, use rubber or neoprene gloves to dispose of it. If skin is exposed to battery fluids, wash with soap and water, and rinse with vinegar. If eyes are exposed to battery chemicals, immediately flush with water for 20 minutes and seek medical attention. Remove and dispose of contaminated clothing.

9. DO NOT SHORT CIRCUIT. A short circuited battery pack may cause fire, personal injury, and product damage. A battery pack will short circuit if a metal object makes a connection between the positive and negative contacts on the battery pack. Do not place a battery pack near anything that may cause a short circuit such as coins, keys or nails in your pocket.

10. DO NOT ALLOW FLUIDS TO FLOW INTO BATTERY PACK. Corrosive and conductive fluids, such as seawater, certain industrial chemicals, and bleach or bleach containing products, etc., can cause a short circuit.

11. STORE YOUR BATTERY PACK AND CHARGER in a cool, dry place. Do not store battery pack where temperatures may exceed 120°F (50°C).

12. ALWAYS SHIP REVOLT BATTERIES IN ACCORDANCE WITH THE CURRENT REGULATIONS GOVERNING THE CHOSEN MODE OF TRANSPORT (E.G. GROUND, AIR, SEA). When in doubt, contact the carrier or other trained Dangerous Goods professional to determine applicable regulations.

13. DISPOSING OF REVOLT BATTERY PACKS need to be disposed of according to federal, state and local regulations. Contact a recycling agency in your area for recycling locations. Even discharged battery packs contain some energy. Before disposing, use electrical tape to cover the terminals to prevent the battery pack from shorting, which could cause a fire or explosion.

TROUBLESHOOTING

• THE POWER INDICATOR IS ON, BUT THE PUMP ISN'T WORKING

Verify the pump is connected to the REVOLT Conversion Kit as shown in Step 2 above. If the pump is connected and the power indicator is lit but the pump still isn't working, the pump is the issue. Reach out to the pump manufacturer for troubleshooting procedures.

• THE POWER INDICATOR IS NOT LIGHTING UP

Make sure the Battery Pack is fully connected to the Dock. A click will be heard when properly attached.

Disconnect the Battery Pack and connect it to the Charger. If the light on the Charger is red, the Battery Pack needs to be charged. The Battery Pack is fully charged when light on Charger is green.

If the Battery Pack is fully charged and the power indicator isn't lighting up, then the connection within the Battery Dock is the issue.

• BAD CHARGER

If the Charger's light stays red for more than 4 hours and the Battery Pack isn't fully charged, the Charger is the issue.

For further troubleshooting, or replacement parts, please give our Customer Support a call at 320-340-6464.

WARRANTY

Every REVOLT series Battery Pack and Charger shall be warranted from defects in workmanship and material, when used within the service and the scope for which they were designed, for a period of one year from date of purchase. Contact our Customer Support for replacements. **DO NOT RETURN PRODUCT TO THE STORE.** Please have original proof of purchase readily available.