

WESTERN®



GLOBAL



TRANSPORTABLE TANK (UN IBC 31A/Y)

05,10,20,30TCG-GLB

WM001

WHY WESTERN?

WITH AN INNOVATIVE RANGE OF SOLUTIONS BACKED BY
A TEAM OF INDUSTRY EXPERTS, WESTERN GLOBAL FOCUSES
ON MAKING YOU MORE PRODUCTIVE, MORE EFFICIENT AND
ULTIMATELY MORE PROFITABLE.

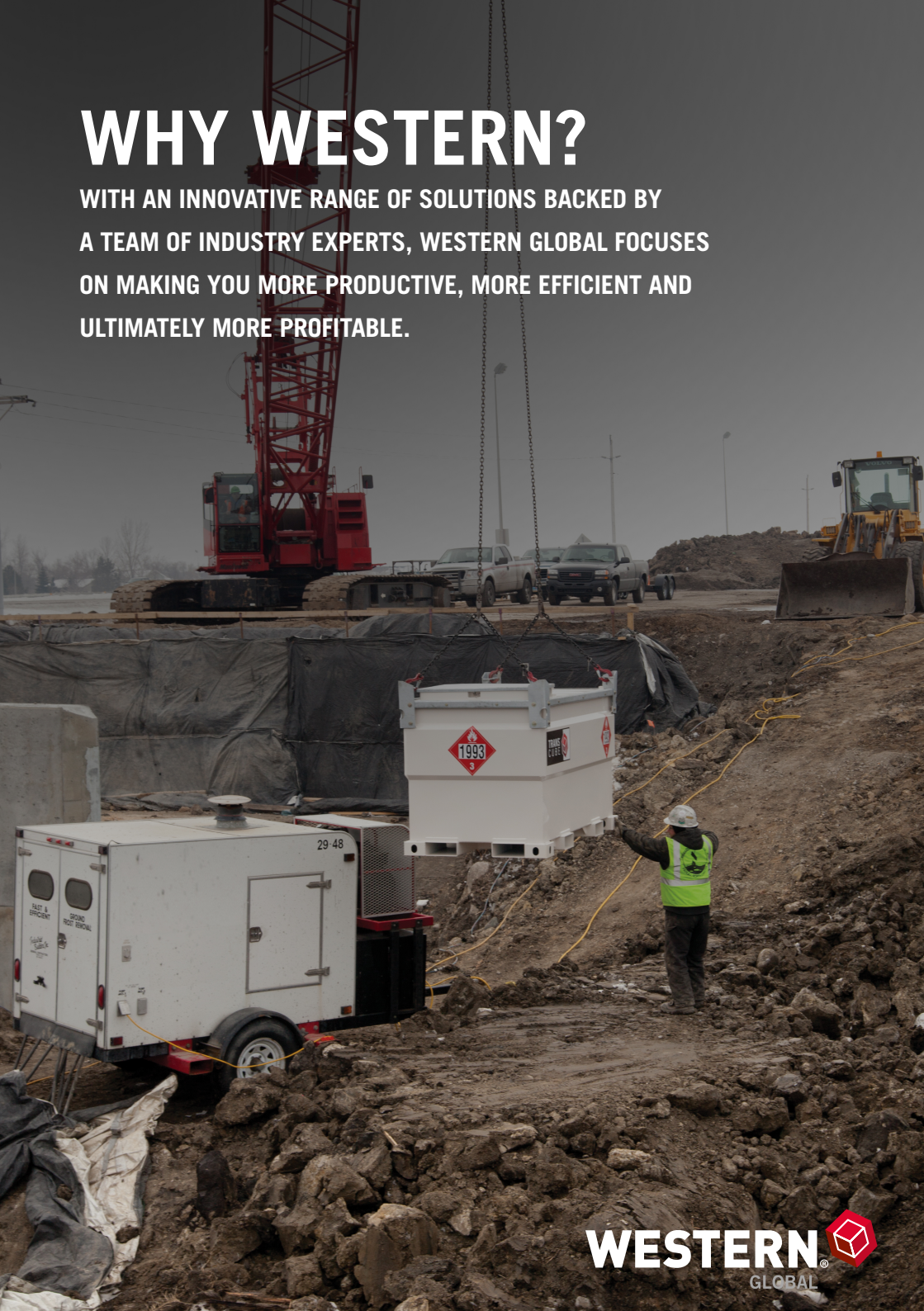

Contents

INTRODUCTION	1
DESCRIPTION	2
SIGN-OFF FORM.....	3
IDENTIFICATION MARKS	4
UNIT SPECIFICATION	6
SAFETY	8
ACCESS AND SECURITY	12
CABINET OVERVIEW	13
CENTRE OF GRAVITY	15
LIFTING & HANDLING	19
FILLING THE TCG	21
DISPENSING FUEL	22
TRANSPORTING	22
STACKING	23
STRAPPING CHARTS.....	24
MAINTENANCE AND SERVICE SCHEDULE	28
STATUTORY INSPECTION AND MAINTENANCE	29
INNER TANK REMOVAL.....	30
TORQUE SETTINGS.....	32
ENVIRONMENTAL RESPONSIBILITY	33
TROUBLE-SHOOTING	34
WARRANTY	35

INTRODUCTION

Thank you for choosing Western Global



Please read the contents of this manual before use.

- Ensure all operators are fully conversant with the procedures for lifting, loading, positioning, filling, maintaining and use of the unit
- By understanding and following the information and procedures in this manual, your tank will give you many years of safe use
- Certain information in this manual is governed by law and is subject to change without prior notice. Great care has been taken to ensure that the information is correct at the time of publication.
- However, it is the owner's / user's sole responsibility to ensure that they and the tank fully comply with all legal requirements. Western Global cannot and will not accept any liability for any inaccuracy or incorrectly stated legal requirements
- Western Global reserves the right to alter product specifications without prior notice or obligation

Western Global Tanks are design approved under various Global / International / National / Regional standards of safety¹

¹ Speak to your local / regional Western Global office for applicable standards.

DESCRIPTION



UN IBC 31A/Y – (IBC) Intermediate Bulk Container

The TCG range of UN IBC 31A/Y tanks have been designed to enable safe storage and transportation of Class 3 Flammable & Combustible fluids.

- The TCG conforms to UN/ADR, CDG Regs (UK), US DOT, and Transport Canada which allows the transportation of the unit containing fuel on the highway/road. There is no need to drain / empty the tank before transporting
- Meets UL 142 and CAN/ULC-S601-14 standard of safety for storage of Class 3 flammable and combustible liquids
- The TCG can be used as an auxiliary fuel tank, feeding generators etc., and for refuelling other equipment via a dedicated fuel pump
- All pipe work and pump systems are stored beneath a secure, lockable cabinet lid
- To aid both transporting and handling, the TCG is fitted with forklift pockets and crane sling lifting points
- Internal baffles ensure safe control of fuel movement when the unit is being lifted or transported
- Containment (Bund) has a capacity equal to 110% of the main tank's capacity
- The design enables maintenance of the containment area without specialty equipment
- The TCG has a comprehensive range of connection points to enable attachment of various fittings and equipment
- The TCG can supply fuel to multiple feed lines

SIGN-OFF FORM

- The equipment provider should follow the general Safety Standards specified by the UN/DOT for the transport of packing Group II and Group III liquids.
- Anyone who will be using and/or maintaining the tank must read and clearly understand ALL Safety, Usage and Maintenance information in this manual
- Periodic reviews of SAFETY and OPERATION should be standard practice for all your equipment
- A sign-off sheet is provided for your records, showing all personnel working with the equipment

I have read and understand the information in the Operator's Manual and have been instructed in the operation of the equipment		
Date	Employee Signature	Employer Signature

IDENTIFICATION MARKS

Each tank is supplied with 3 unique identification numbers.

1. UN IBC Serial Number
2. Manufacturing Serial Number
3. UL/ULC Serial Number

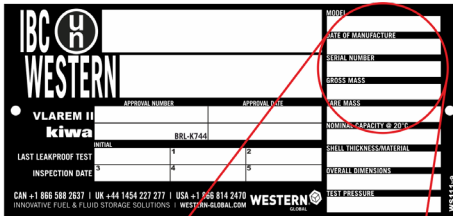

1, UN IBC Serial Number

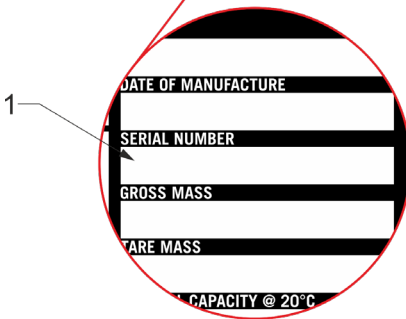

The UN IBC Plate is located on the external of the tank (front or Side near the cabinet area

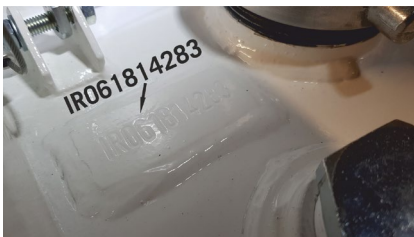

2, Manufacturing Serial Number

Tank number is positioned in the cab area and will be permanently attached to the main tank.

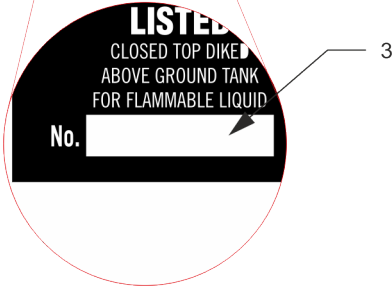
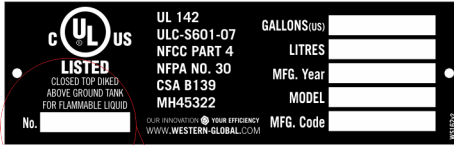

3, UL/ULC Serial Number

The UL Plate is located on the external of the tank (front or Side near the cabinet area

Record your serial numbers here

UN IBC Data-plate Serial Number	
Manufacturing Serial Number	
UL/ULC Data plate Serial Number	
Plant Number*	

*Optional customer plant number

UNIT SPECIFICATION

Capacities / Dimensions

Model	Capacity					
	Litres		US Gallon		Imp. Gallon	
	Nominal	95%	Nominal	95%	Nominal	95%
05TCG	499	474	132	125	110	104
10TCG	949	902	251	238	209	198
20TCG	2091	1986	552	525	460	437
30TCG	2980	2831	787	748	656	623

Model	Weight			
	KG		LBS	
	TARE	GROSS	TARE	GROSS
05TCG	415	889	915	1960
10TCG	540	1442	1190	3179
20TCG	823	2809	1814	6193
30TCG	1100	3931	2425	8666

Model	Dimension					
	Metric (mm)			Imperial (Inch)		
	L	W	H	L	W	H
05TCG	1150	1150	855	45	45	34
10TCG	1155	1155	1324	45	45	52
20TCG	2280	1150	1320	90	45	52
30TCG	2288	1550	1323	90	61	52

Current UN Reference number

UN Certificate of Packaging reference number TCG(G)

05TCG	31A/Y/** **/B/844/160021/1726/1014
10TCG	31A/Y/** **/B/844/160019/3106/1726
20TCG	31A/Y/** **/B/844/160022/6000/3333
30TCG	31A/Y/** **/B/844/160020/8347/4710

** ** = MM YY of manufacture.

Legacy UN reference numbers

Legacy UN IBC Certificate of Packaging reference numbers for older North America tanks.

IMPORTANT - FOR REFERENCE ONLY

Transport Canada - UN IBC Certificate of Packaging reference number

05TCG	31A/Y/** **/CAN / WEC 4-627 / 1661 / 923
10TCG	31A/Y/** **/CAN / WEC 4-627 / 2725 / 1514
20TCG	31A/Y/** **/CAN / WEC 4-627 / 5070 / 2817
30TCG	31A/Y/** **/CAN / WEC 4-627 / 7097 / 3943

** ** = MM YY of manufacture

Legacy UN IBC Certificate of Packaging reference numbers for older European tanks.

IMPORTANT - FOR REFERENCE ONLY

UN Certificate of Packaging reference number

05TCG	31A/Y/** **/GB/WESTERN - 6176/2146/972
10TCG	31A/Y/** **/GB/WESTERN - 5250/2840/1578
20TCG	31A/Y/** **/GB/WESTERN - 5249/5866/3259
30TCG	31A/Y/** **/GB/WESTERN - 5248/8264/4591

** ** = MM YY of manufacture

SAFETY



**Before using this equipment and to avoid personal injury,
carefully read and understand these instructions.**

General

- If there is anything you do not understand, contact your supplier for advice
- The unit must be operated by authorised personnel only
- This unit must not be moved, filled, maintained or operated by persons who are under the influence of alcohol or drugs, tired or unwell
- You MUST perform a risk assessment before using this equipment to ensure your safety and the safety of others
- Wear the correct Personal Protective Equipment for the task you are performing
- Do not wear loose jewellery or clothing that may get in the way or become trapped in the mechanism
- Inspect the unit before use, if there is any doubt about its condition, DO NOT USE IT
- Do not smoke – No naked flames near tank
- Please follow all necessary Transportation of Dangerous Goods act, regulations and codes, National and Regional Fire Safety Codes, and other Installation Codes as applicable in your region / country of use.



No Smoking



No Open Flames



Authorised Access Only



Wear Safety Glasses



Wear Safety Helmet



Wear Ear Protection



Wear Safety Shoes



Wear Safety Gloves



Wear Coveralls

NOTE: Please check with the local authority for any further site requirements or regional legislation. A full risk assessment may be required

Limitations of use

- The TCG is designed for the safe storage of Class 3 Flammable & Combustible fluids, on site or in transit
- Each unit should be filled up to a maximum of 95% of its stated Nominal capacity

Safe practice

The storage, transportation and dispensing of Flammable & Combustible fluids is governed by law and it is the user/operator who has sole responsibility to ensure that any such rules and regulations are abided by.

Earthing point

- The TCG is fitted with an earthing point. This is found on the front of the tank on the bottom frame
- Used to protect against static electricity build up, this should be connected to a suitable earthing point, by a qualified electrician, when in use

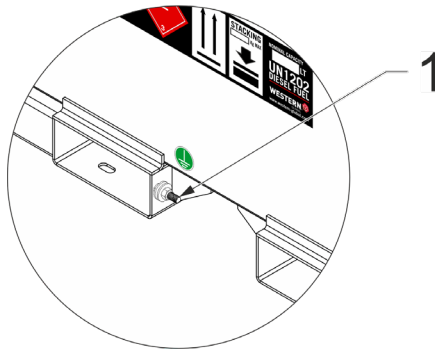

1. Earth point

Venting

Each unit has 2 common vents installed; these are in the Cab Area of the tank.

IMPORTANT: Do not operate the unit if these vents are damaged or missing

- 2" Pressure Vacuum Vent – Allows movement of air into the unit at low pressure during the pumping process and allows air out of the unit at a higher pressure to stop an over pressure of the internal tank
- ¼" Roll over Vent – Allows free flow air into and out of the tank at all times, this low volume vent will fully close if the tank is inverted or turned on its side
- For static installation follow local regional, state and national Fire Safety Codes and other governing Installation Codes for the Normal and Emergency Venting equipment and appurtenances.

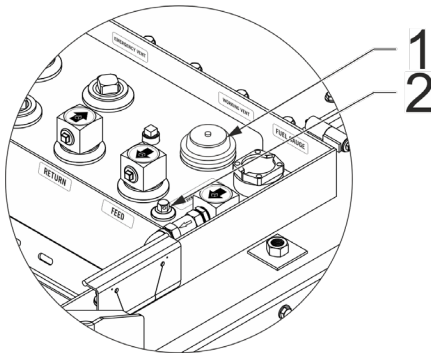

1. 2" Pressure / Vacuum Vent
2. ¼" Roll Over Vent

ACCESS AND SECURITY



SAFETY. Ingress to the inner tank must only be carried out by trained personnel and after a full risk assessment has been carried out.

Access to the inner tank

For maintenance, inspection and cleaning, access can be made through the installed access lid located on the top of the tank.

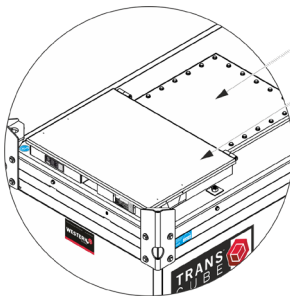

1
2

1. Access Lid
2. Cabinet hatch

Access to the Cab Area

- The cabinet hatch is constructed of a heavy-duty steel, care should be taken when opening or closing
- The cabinet hatch should be kept closed when the TCG is not being used to protect the fittings and containment area from weather conditions.

Security

- The TCG is fitted with a range of connections to enable the supply of Flammable & Combustible fluids. All the connections are housed behind the cabinet hatch, which can be locked using a suitable security padlock

CABINET OVERVIEW

Standard EU Unit

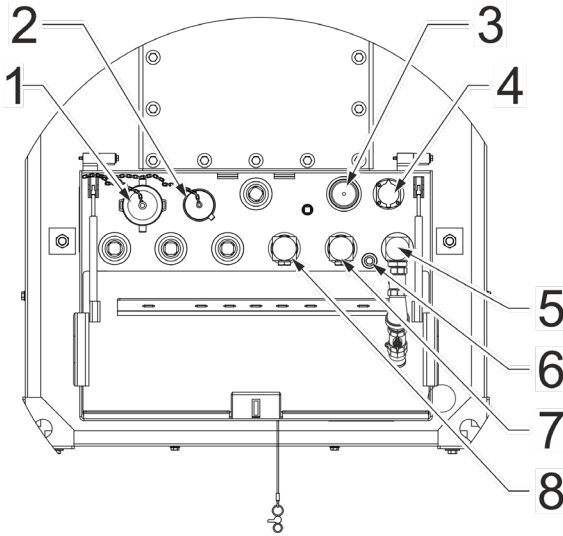

1. 3" NPTS Fill Point
2. 2" BSPP Fill Point
3. 2" NPT Pressure / Vacuum Vent
4. Fuel Gauge
5. 1" Pump Feed
6. ¼" NPT Roll Over Vent
7. ½" NPT Feed
8. ½" NPT Return

Standard NA Unit

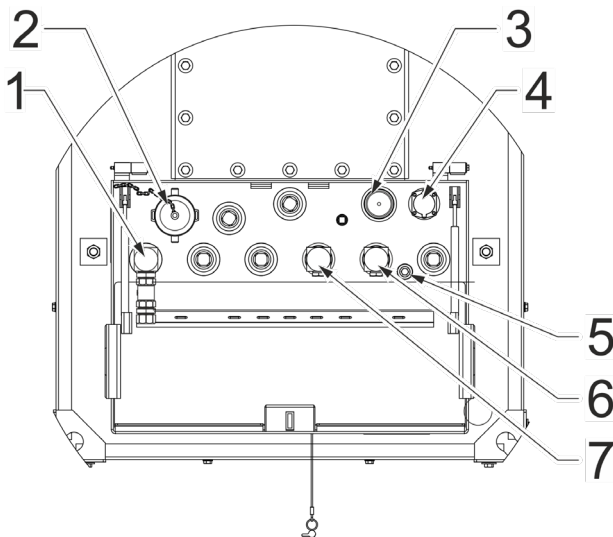

1. 1" Pump Feed
2. 3" NPTS Fill Point
3. 2"NPT Pressure / Vacuum vent
4. Fuel Gauge
5. ¼"NPT Roll Over Vent
6. ½" NPT Feed
7. ½" NPT Return

CENTRE OF GRAVITY

05TCG Centre of Gravity²



Center Of Gravity

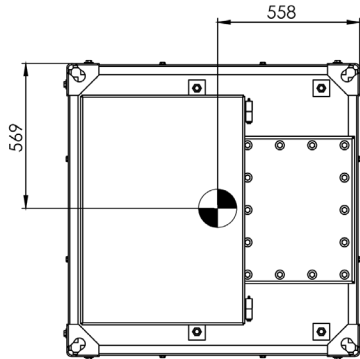
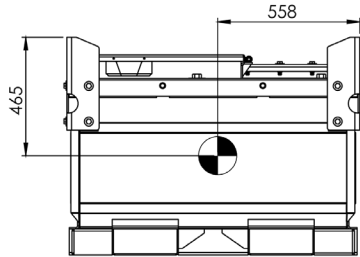
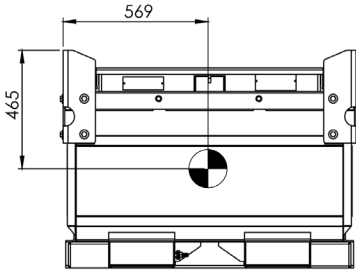

² Based on empty tank.

10TCG Centre of Gravity³



Centre Of Gravity

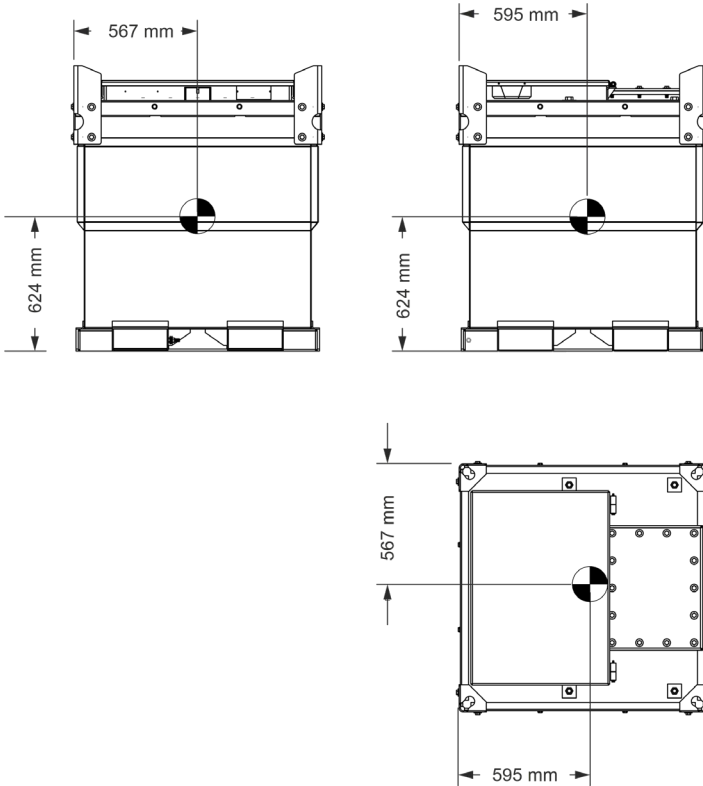

³ Based on empty tank.

20TCG Centre of Gravity⁴



Centre Of Gravity

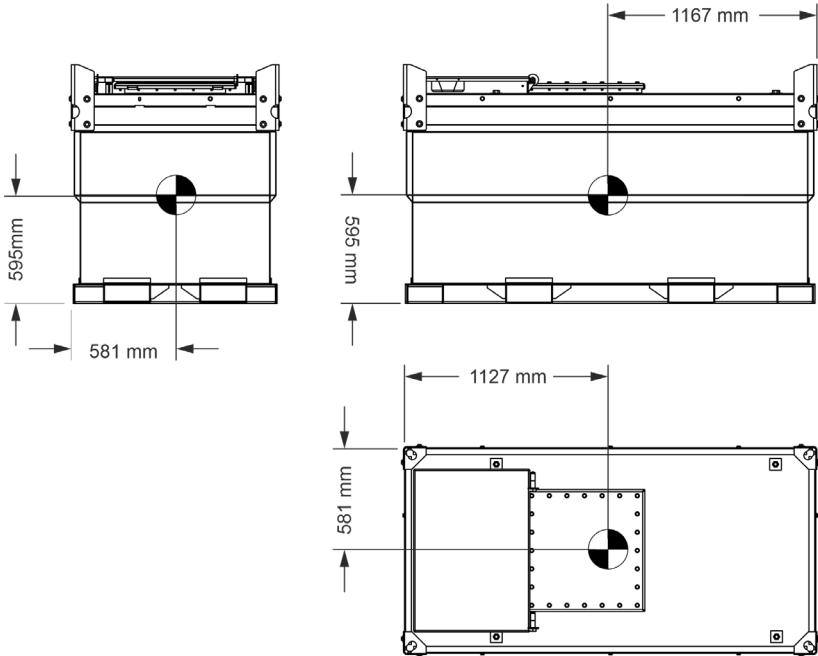

⁴ Based on empty tank.

30TCG Centre of Gravity⁵



Centre Of Gravity

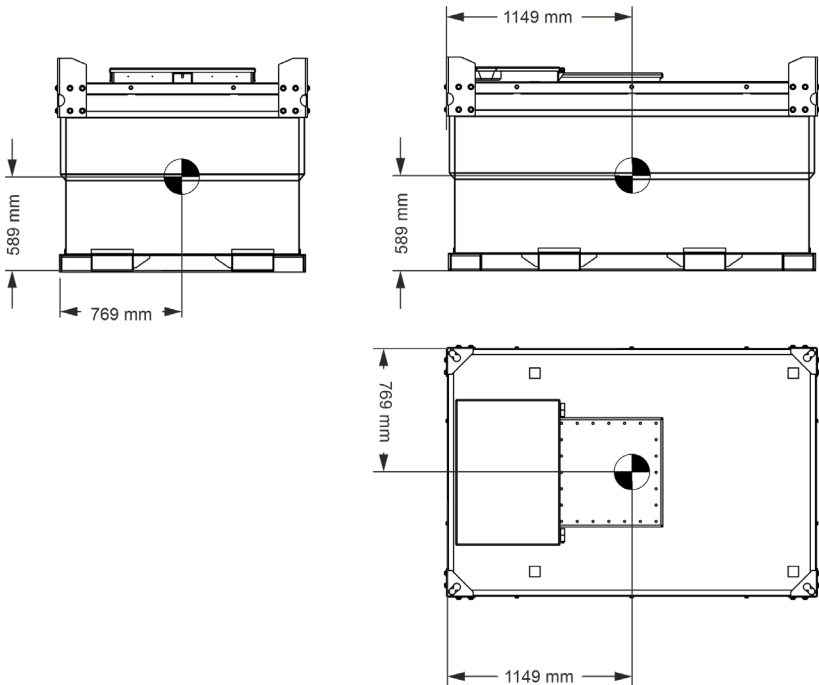

⁵ Based on empty tank.

LIFTING & HANDLING

IMPORTANT: Always prepare a Lifting Plan/Risk Assessment.

By Forklift / Tele-handler

- Each TCG is fitted with forklift pockets which are designed to allow the TCG to be raised by a forklift/tele-handler. The TCG can be lifted from all 4 sides. This must be considered in your risk assessment
- It is important that the total gross weight of the TCG is not more than half (50%) of the forklift's maximum SWL. Ensure that the forklift's forks are set to the correct width for the TCG's fork pockets

By Crane

- Lifting of tanks should only be undertaken by a competently trained person
- You will require a lifting device (crane) and suitable four-leg chain slings fitted with hooks and safety catches
- Always check and obtain official confirmation from the chain sling supplier that it is both suitable in SWL and chain length
- With the chain slings correctly attached to the lifting equipment, attach each hook to the lifting points. Once attached, ensure the catches fitted to all hooks are closed
- Attach tag lines to the base of the unit to control rotation
- Lift the chains until taut and check that the hooks are correctly positioned with catch closed and that the chains are not twisted. If a fault is found, lower the chain and reattach correctly
- Lift the unit until just off the ground and check that it is balanced and stable. Once you are satisfied that everything is correctly and safely set up, you can continue with the lift.

The TCG must ONLY be lifted via the dedicated crane lifting point(s) found in each corner. See Lifting Points

- ALL lifting point(s) must be used during a lift
- The lifting points MUST be inspected for condition and safe use
- DO NOT lift from the base, with polyester slings

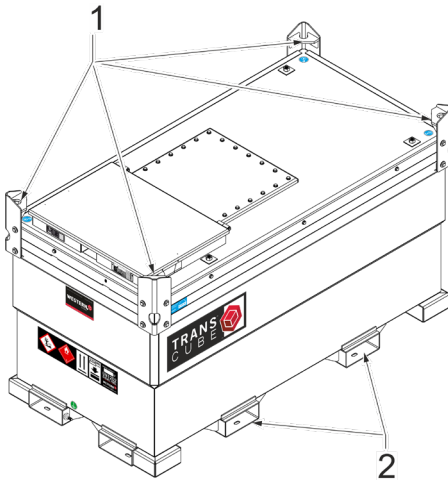

1. Lifting Points
2. Fork Pockets

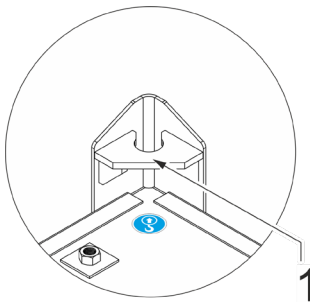

1. Lifting Point
LIFT HERE ONLY

WARNING
Do not allow anyone under the raised load at any time or for any reason.

- Use suitable tag lines to help control the movement of the unit and always keep constant communication with the crane operator
- Move slowly and smoothly to ensure full control of the unit's whereabouts
- Lower the unit to its required resting place using great care

Positioning

Where the TCG is to be permanently positioned for use (long or short term) it is important that certain aspects are considered

- You should make sure that both supplying vehicle and receiving vehicle have safe and easy access to the TCG
- The position should be selected where the unit will be protected from accidental impact
- Consideration should be given to the location of overhead services such as telecommunications, power cables and overhanging obstructions. Be aware of the location of underground services, such as drains, and manhole covers
- You must also consider the ground surface and make sure it can support the weight of the TCG, its contents when full and any stored equipment such as pumps, without the risk of subsidence. It should be positioned on smooth and level ground with access available to the rear and sides
- Allow for access that may be required by the emergency services should it become necessary

FILLING THE TCG

- **DO NOT FILL TANK WHEN DISPENSING IS IN OPERATION**
- Only fill the TCG to 95% of its nominal capacity
- Filling should only be performed by a suitably trained person and only following a full risk assessment
- The TCG must be positioned on a firm level surface, whether static, truck or trailer mounted
- Where truck or trailer mounted, ensure that the parking brake is set to ON and the wheels are chocked
- Before filling, ensure that you have a suitable spill containment kit and that you are wearing all required PPE
- Nozzle Fill - Unscrew and remove the 3" filler cap, place the filling nozzle in the 3" port.
- Hard Couple fill (EU Only) - Unscrew and remove the 2" filler cap, connect the 2" delivery hose. Remove the 3" cap to allow venting
- **Do not leave the nozzle unattended during the filling process**
- Observe the fuel level gauge for an indication of tank capacity, then once filled, replace the filler cap and clean up any spills

DISPENSING FUEL

There are two options available for dispensing/supplying fuel. Either manually via a fuel pump and nozzle or by direct coupling to the equipment such as a generator.

- **By Fuel Pump** - For the information about any pump system fitted to this TCG, please refer to documents supplied with the pump.
- **Direct Coupling** - enables continuous fuel feed to equipment such as generators where fuel is required continuously.

TRANSPORTING

- **When transporting ALL ports, valves and vents must be closed**
- Ensure pump is turned off
- Close and lock the access lid
- The TCG must be secured firmly to its means of transport
- Use tie down points shown below

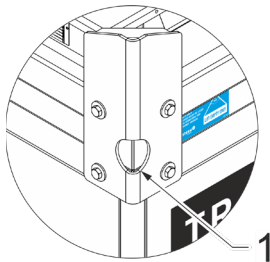

1. Tie Down Point

Each TCG incorporates baffle plates, these are situated in the inner tank. The baffle plates are designed to restrain and regulate the flow of fluid and remove the risk of damage to the tank during transport.

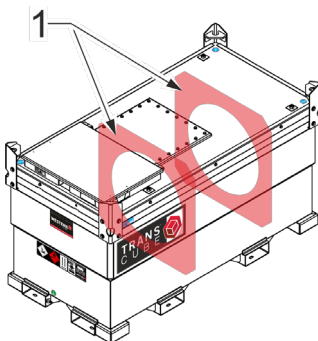

1. Baffles

The baffle plates run the width of the unit and are only effective if the tank is loaded correctly onto the trailer, truck etc. NOTE: always load the tank as shown below with the cabinet running in the direction of travel.

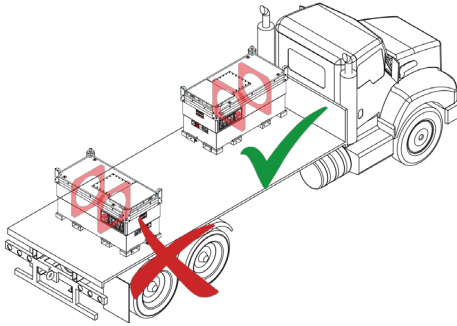

! IMPORTANT !

When transporting ALL ports, valves, vents and openings must be closed

STACKING

- The TCG is designed with the structural strength to allow stacking 2 high when full and 3 high when empty.
- Always mate the corner brackets together to stabilise the stack.
- Use only a hoist or forklift with the required lift capacity to raise, lower or stack the tanks.

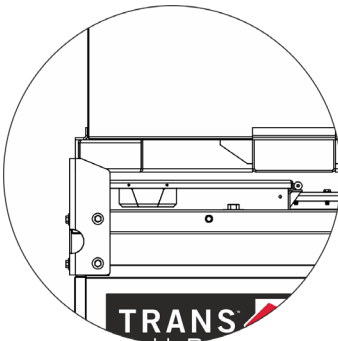

Stacking Arrangement

STRAPPING CHARTS

05TCG

Depth (mm)	Depth (in)	Fuel Level (Litre)	Fuel Level (US Gallon)	Fuel Level (Imp Gallon)
571.5	22.5	499	131.8	109.8
535	21.1	474	125.2	104.3
500	19.7	430	113.6	94.6
450	17.7	394	104.1	86.7
400	15.7	357	94.3	78.5
350	13.8	318	84	70
300	11.8	278	73.4	61.2
250	9.8	236	62.3	51.9
200	7.9	192	50.7	42.2
150	5.9	146	38.6	32.1
100	3.9	99	26.2	21.8
50	2	50	13.2	11
0	0	0	0	0

1. Highlighted on the strapping chart is the maximum safe fill level @ 95% of the nominal volume. DO NOT FILL ABOVE THIS LEVEL
2. The dip chart volume is taken from the lowest point in the tank.
3. When programming a level monitoring system, the difference in floor height at the port location (where the instrument is mounted) should be subtracted from the fill height for each volume increment line to equate to corresponding fill height at the instrument location.

10TCG

Depth (mm)	Depth (in)	Fuel Level (Litre)	Fuel Level (US Gallon)	Fuel Level (Imp Gallon)
1041	41	949	250.7	208.8
1000	39.4	910	240.4	200.2
970	38.2	902	238.3	198.4
950	37.4	875	231.2	192.5
900	35.4	840	221.9	184.8
850	33.5	802	211.9	176.4
800	31.5	764	201.8	168.1
750	29.5	723	191	159
700	27.6	682	180.2	150
650	25.6	639	168.8	140.6
600	23.6	594	156.9	130.7
550	21.7	548	144.8	120.5
500	19.7	500	132.1	110
450	17.7	452	119.4	99.4
400	15.7	402	106.2	88.4
350	13.8	352	93	77.4
300	11.8	301	79.5	66.2
250	9.8	251	66.3	55.2
200	7.9	201	53.1	44.2
150	5.9	151	39.9	33.2
100	3.9	100	26.4	22
50	2	50	13.2	11
0	0	0	0	0

1. Highlighted on the strapping chart is the maximum safe fill level @ 95% of the nominal volume. DO NOT FILL ABOVE THIS LEVEL
2. The dip chart volume is taken from the lowest point in the tank.
3. When programming a level monitoring system, the difference in floor height at the port location (where the instrument is mounted) should be subtracted from the fill height for each volume increment line to equate to corresponding fill height at the instrument location.

20TCG

Depth (mm)	Depth (in)	Fuel Level (Litre)	Fuel Level (US Gallon)	Fuel Level (Imp Gallon)
1041	41	2091	552.4	460
1000	39.4	2065	545.5	454.2
982	38.7	1986	524.6	436.9
950	37.4	1973	521.2	434
900	35.4	1880	496.6	413.5
850	33.5	1785	471.5	392.6
800	31.5	1688	445.9	371.3
750	29.5	1590	420	349.8
700	27.6	1491	393.9	328
650	25.6	1390	367.2	305.8
600	23.6	1288	340.3	283.3
550	21.7	1184	312.8	260.4
500	19.7	1080	285.3	237.6
450	17.7	972	256.8	213.8
400	15.7	864	228.2	190.1
350	13.8	756	199.7	166.3
300	11.8	648	171.2	142.5
250	9.8	540	142.7	118.8
200	7.9	432	114.1	95
150	5.9	324	85.6	71.3
100	3.9	216	57.1	47.5
50	2	108	28.5	23.8
0	0	0	0	0

1. Highlighted on the strapping chart is the maximum safe fill level @ 95% of the nominal volume. DO NOT FILL ABOVE THIS LEVEL
2. The dip chart volume is taken from the lowest point in the tank.
3. When programming a level monitoring system, the difference in floor height at the port location (where the instrument is mounted) should be subtracted from the fill height for each volume increment line to equate to corresponding fill height at the instrument location.

30TCG

Depth (mm)	Depth (in)	Fuel Level (Litre)	Fuel Level (US Gallon)	Fuel Level (Imp Gallon)
1050	41.3	2980	787.2	655.5
1000	39.4	2857	754.7	628.5
990	39	2831	747.9	622.7
950	37.4	2730	721.2	600.5
900	35.4	2600	686.8	571.9
850	33.5	2469	652.2	543.1
800	31.5	2335	616.8	513.6
750	29.5	2200	581.2	483.9
700	27.6	2062	544.7	453.6
650	25.6	1923	508	423
600	23.6	1781	470.5	391.8
550	21.7	1637	432.4	360.1
500	19.7	1490	393.6	327.8
450	17.7	1341	354.3	295
400	15.7	1192	314.9	262.2
350	13.8	1043	275.5	229.4
300	11.8	894	236.2	196.7
250	9.8	745	196.8	163.9
200	7.9	596	157.4	131.1
150	5.9	447	118.1	98.3
100	3.9	298	78.7	65.6
50	2	149	39.4	32.8
0	0	0	0	0

1. Highlighted on the strapping chart is the maximum safe fill level @ 95% of the nominal volume. DO NOT FILL ABOVE THIS LEVEL
2. The dip chart volume is taken from the lowest point in the tank.
3. When programming a level monitoring system, the difference in floor height at the port location (where the instrument is mounted) should be subtracted from the fill height for each volume increment line to equate to corresponding fill height at the instrument location.

MAINTENANCE AND SERVICE SCHEDULE

V = Visual inspection P = Physical Check L = Lubricate R = Replace							
Item	Daily	Weekly	Monthly	6 Monthly	Yearly	Other	Reference / Comments
General							
Housekeeping		V		P			Check site and tank. Remove debris etc.
Firefighting media (if fitted)		V		P			V = Check in place and unused P = Test pressure and function
Doors			V			L	V = Visual inspection L = Greases hinges
Signage			V/R				Check damage and wear
Tank							
Ball valves		P					P = Check operation
Vents, fittings and pipelines		V		P			V = Visual checks for leaks and damage P = physical check, bolt tightness, paint deterioration
Interstitial space (Containment)		P					Check for water or product
Tank earthing				V		P	V = Visual check OK P = Test continuity
Level gauges		V				P	V = Visual checks for leaks and damage P = Remove and check operation

STATUTORY INSPECTION AND MAINTENANCE

To retain the UN IBC approval⁶, it is required that the owner of the TCG carries out regular inspections and ensures that a record of each inspection is kept. Where fault is found, the unit **MUST** be removed from service until the fault is rectified and the unit is retested successfully.

Every 2 ½ years

- External inspection
- Function of all services equipment
- Leak test.

Every 5 years

- Internal inspection
- External inspection
- Function of all services equipment
- Leak test.

NOTE: The 2 ½ and 5-year Inspection must be carried out by a competent person

Record Keeping

A report of each inspection and test shall be kept by the owner of the IBC at least until the next inspection or test. The report shall include the results of the inspection and test and shall identify the party performing the inspection and test.

Owner			Date of manufacture		
Model					
Serial Number			Plant Number		
Capacity					
Date	2.5 or 5 Year	Pass or Fail	Comments	Inspectors Name	Signature

⁶ For United States - Periodic Testing is to be carried out by DOT certified person or approved facility under 49CFR
 For Canada – Transport Canada approved and Registered testing facility with valid certification under CAN/CGSB43.146-2016.

INNER TANK REMOVAL

For periodic inspection you may be required to remove the inner tank from the containment. Follow local Health and Safety rules when carrying out this operation.

IMPORTANT - Ensure the tank is empty before lifting.

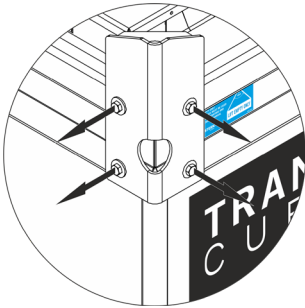

1. Remove all 4 corner brackets. Store brackets, nuts and bolts safely

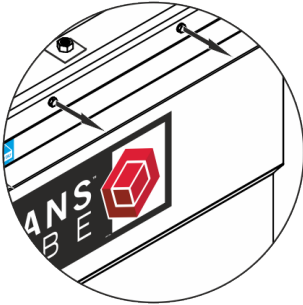

2. Remove 2 x side and 2 x end rails. Store rails, nuts and bolts safely

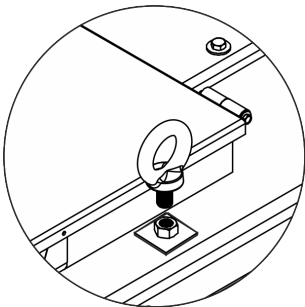

3. Insert 4 x M22 lifting eyes in each corner of the inner tank

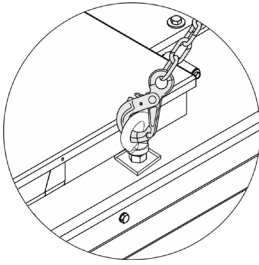

4. Using a 4-leg lifting chain attached to each corner carefully remove the inner tank

To re-install the inner tank into the containment, follow steps 1 – 4 in reverse. Always ensure the bolts are torqued.



Typical Lifting Eye M22

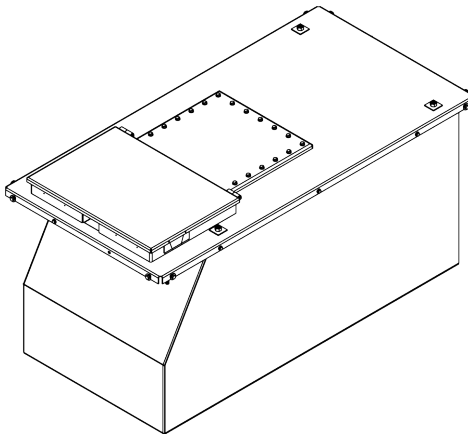

Inner tank removed from containment

TORQUE SETTINGS

Nuts and Bolts

If the tank is required to be dismantled and re-assembled the tank nuts and bolts used are required to be torqued, torque settings are shown in the table below.

Metric Torque Specifications

Size	Typical Maximum Tightening Torque Nm (<i>lb ft</i>)	
	Property Class	
	Grade 8.8	Grade 10.9
M8	30 (21)	40 (30)
M10	55 (42)	75 (60)
M12	100 (74)	135 (106)

Torque figures indicated above are valid for lightly oiled threads. Therefore, do not grease or oil bolts or cap screws unless otherwise specified.

Torque value for bolts and cap screws are identified by their head markings (property class).

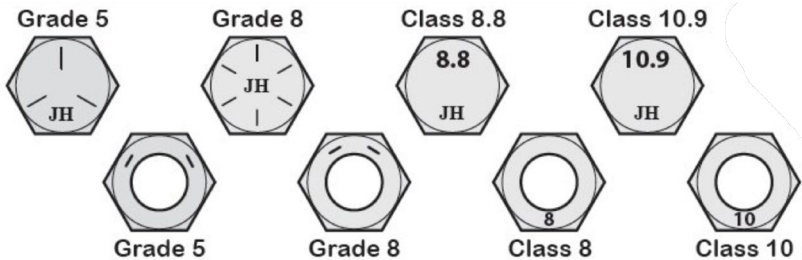

ENVIRONMENTAL RESPONSIBILITY

Correct and considerate management of Flammable & Combustible fluids, its storage and transfer are the responsibility of everyone who operates or maintains this equipment. All necessary precautions should be made to prevent spills and subsequent pollution of the environment.

Have in place a clear action plan to deal with accidental spill, no matter how small or large. Ensure that you have a Flammable & Combustible fluids spill containment kit available and that you understand its correct use.

Spills

Should a spill occur when emptying the containment, or when filling or transferring fuel, clear the spill as quickly as possible using absorbent material. Ideally, you should use a dedicated spill kit which will contain all the necessary items to retain and remove such a spill.

- DO NOT hose the area down or use any detergents
- DO NOT allow the fuel to enter drains or watercourses
- Spills must be reported to your local Authority
- All material used to retain and remove a spill should be bagged and collected by a registered carrier

Containment

The TCG containment area safeguards against any spill exiting the unit and polluting the immediate area. The containment is designed to retain up to 110% of the unit's primary tank maximum storage capability.

- Check regularly for liquid in the containment
- Remove any water
- Take immediate remedial action if product or water is found

WARNING

Waste may only be collected by a registered carrier.

Disposal

When maintaining, servicing or disposing of the TCG or consumable components, do not dispose of contaminated parts within general refuse.

Refer to local authority regulations for their correct disposal.

TROUBLE-SHOOTING

The Transcube is a simple and reliable system

Below we have listed common problems, causes and solutions that you may encounter.

If a problem is difficult to solve, even after having read through this trouble-shooting section, please call your local Western Global distributor or dealer.

Before you call, please have the tanks Identification Marks ready (Serial and Tank numbers)

PROBLEM	CAUSE	SOLUTION
Pump will not run	No Power	Connect power wires to correct power source
	Pump Off	Turn pump on
Fuel in containment	Loose fitting	Tighten fitting
	Leaking Coupler	Replace coupler
	Over filling	Watch fuel gauge when filling. Do not fill past 95% of the nominal capacity
Water in containment	Lid left open to weather	Keep lid closed

WARRANTY

The Company undertakes to replace or repair, free of charge, any defect which the Company considers to be due to faulty workmanship or material within 36 months (or otherwise stated) of the sale date, except for:

- Defects arising from neglect, misuse or unauthorised modifications.
- Damage caused by abuse, misuse, dropping or other similar damage caused by or because of a failure to follow transportation, storage, loading or operation instructions.
- Alterations, additions or repairs carried out by persons other than the manufacturer or their recognised distributors.
- Transportation or shipment costs to and from the manufacturer or their recognised agents, for repair or assessment against a warranty claim, on any product or component.
- Materials and/or labour costs to renew, repair or replace components due to normal wear and tear.
- Faults arising from the use of non-standard or additional parts, or any consequential damage or wear caused by the fitting or use of such parts.

IMPORTANT

Warranty may, at the sole discretion of the manufacturer, be voided if the scheduled service/inspections are not carried out in accordance with the logbook. The manufacturer and/or their recognised agents, directors, employees or insurers will not be held liable for consequential or other damages, losses or expenses in connection with, or by reason of, or due to the inability to use the product for any purpose.

NEED MORE INFORMATION?

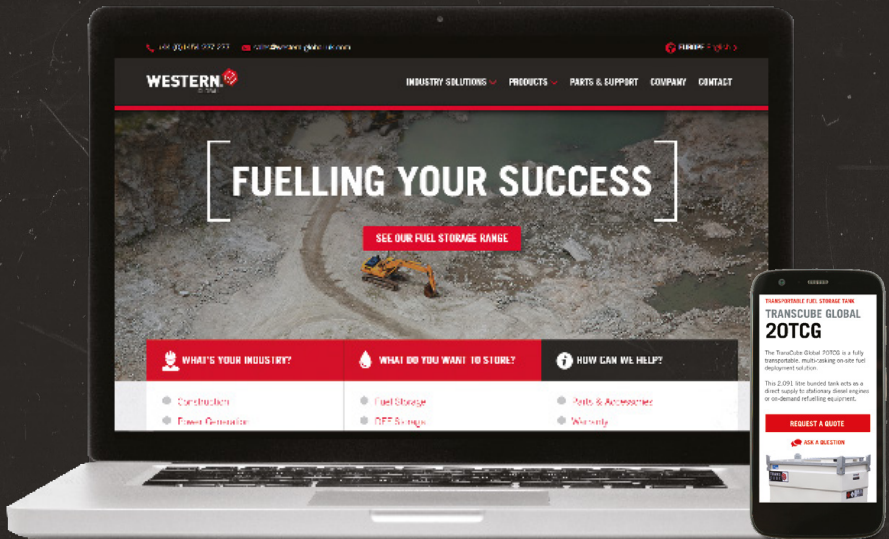

- Product Details and Specifications
- Accessories and Support Information
- Company News & Updates

VISIT WESTERN-GLOBAL.COM





HQ - WESTERN GLOBAL LTD

Western House
Broad Lane, Yate
Bristol - BS37 7LD
Tel: +44 (0) 1454 227 277
sales.uk@western-global.com

CANADA

Tel: +1 (204) 772 6525
info@western-global.ca

USA

Tel: +1 (203) 847 4300
info@western-global.us.com

All rights reserved. No part of this manual may be reproduced, stored in a retrieval system, or transmitted, in any form or by any means, electronic, mechanical, photocopying, recording or otherwise without the prior permission of Western Global Ltd