

SCHWINN®

Daytripper

CARGO TRAILER

13-SC320

OWNER'S MANUAL

This manual contains safety, assembly, use and maintenance instructions. Read these instructions carefully before use and keep them for future reference. Your safety may be affected if you do not follow these instructions. The Schwinn Bicycle Trailer must be assembled by an adult who has read and understands the instructions in this manual. Keep the packaging away from children and dispose all packaging before use.

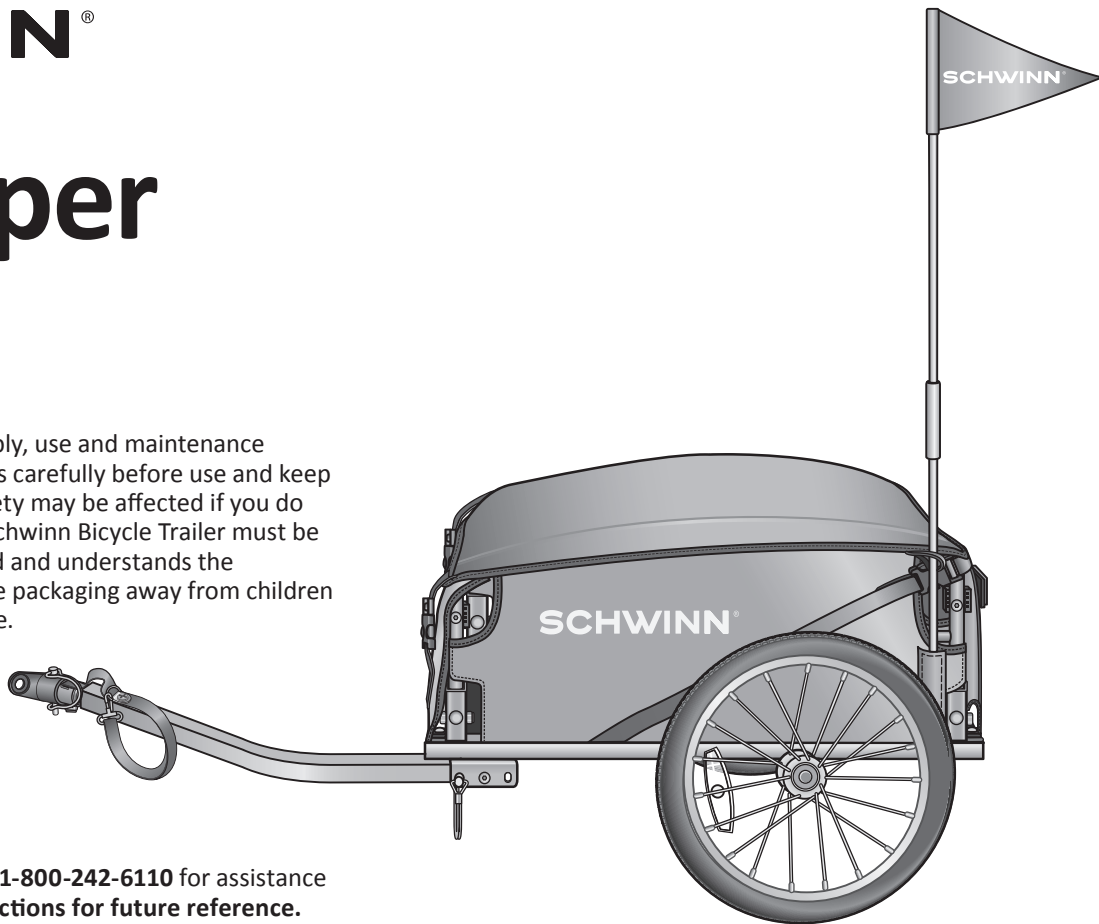

Do not return to store. Call toll free **1-800-242-6110** for assistance and replacement parts. **Keep instructions for future reference.**

Thank You

For purchasing the Schwinn Cargo Trailer. If you have any questions or comments our customer service hours are:

8:00 AM - 5:00 PM Monday through Friday CST.

You may also reach us through the following:

Web: www.pacific-cycle.com

Email: customerservice@pacific-cycle.com

Mail: P. O. Box 344
4730 E. Radio Tower Lane
Olney, IL 62450

Important!

Do not return the product to the store. Please contact customer service at 1-800-242-6110 for assistance and replacement parts.

Contents

1 SAFETY	1
Assembly	1
Safe Riding Warnings	1
Trailer Use Warnings	2
Care, Tips, Guidelines	2
2 PARTS AND FEATURES	3
3 ASSEMBLY	4
Extend and Secure the Tow Bar	4
Attach the Wheels	5
Unfold the Frame	7
Insert the Safety Flag	10
4 TRAILER ATTACHMENT	11
Attach the Safety Strap	16
5 USING THE CARGO TRAILER	17
6 DISASSEMBLY AND STORAGE	19
7 MAINTENANCE AND PARTS	22
Care	22
Accessories	22
8 WARRANTY	22

1 Safety

WARNING!

FAILURE TO FOLLOW THE SAFETY INSTRUCTIONS LISTED BELOW MAY RESULT IN SERIOUS INJURY OR DEATH. Always read and understand the information and warnings in this manual before using the Bicycle Trailer.

If you are unsure of any information in this manual or have a question regarding assembly or use please call customer service. Always keep this manual for reference and include it with resale of the Bicycle Trailer.

ASSEMBLY

- An adult who has read and understands the information and warnings in the manual shall assemble this product according to manufacturer's instructions.
- Do not use the product if there are any missing or damaged parts. Do not return the product to the store. Please contact customer service at **1-800-242-6110** for assistance and replacement parts.
- There are pinch points between the sidewalls and the frame of the trailer that may cause injury. Fold or unfold the trailer slowly using caution.
- Dispose of all plastic bags and wrapping material immediately.

SAFE RIDING WARNINGS

- Weight limit is 100 lbs. Do not carry loads exceeding 100 lbs, as the extra weight and height will increase the center of gravity, increasing the risk of tip over
- Do not carry items that exceed the trailer's frame by more than 8" (high). Carrying taller loads will increase the trailers center of gravity and increase the risk of tip over. Be sure to always keep the center of gravity as low as possible
- Do not carry humans or pets in this trailer
- Do not ride bicycle at excessive speeds as it increases the risk of the trailer tipping
- Avoid riding with the trailer on icy or slippery terrain, or when inclement weather makes bicycling unsafe
- Avoid riding on sloped terrain, with wheels perpendicular to the slope. Doing so will increase the likelihood of the trailer tipping
- Never tow trailer with any motorized vehicle
- Riding with this trailer increases your turning radius. Be sure to allow for extra clearance around curbs, signs, cars, and other obstacles.
- Make sure tow bar safety strap is properly secured, for additional safety

WARNING!

TRAILER USE WARNINGS

- The canopy must be properly fastened in open or closed positions (attached with buckles and secured by elastic straps) to avoid interference with the bicycle or ground
- We do not recommend carrying loads that extend past the back of the trailer's frame. This can create a hazard by interfering with the bicycle, ground, or other obstacles such as curbs, signs, cars, etc.)
- Tires must be properly inflated prior to use. Please refer to the PSI recommendations on the tire for proper inflation levels
- Over inflation of tires may result in tire failure and risk of serious injury. Do not exceed the maximum inflation pressure shown on the tire
- Inspect and maintain the bicycle trailer regularly, before each use. Ensure trailer hitch is properly attached and secure prior to riding
- Do not leave trailer outside after use. Inclement weather and harsh elements may stress the fabric on the trailer
- Never leave your cargo unattended
- Do not transport flammable, explosive, poisonous, or other hazardous material in your trailer

CARE/TIPS/GUIDELINES

- The canopy and side wall material is not weather resistant. The contents of the trailer may get wet during inclement weather
- Riding with a trailer will increase your normal braking distance. Practice braking with the trailer in areas with less traffic.
- Load heavier items in the front of the trailer bed to increase stability
- Be sure to secure all loads with properly sized fasteners, ropes, or straps

2 Parts and Features

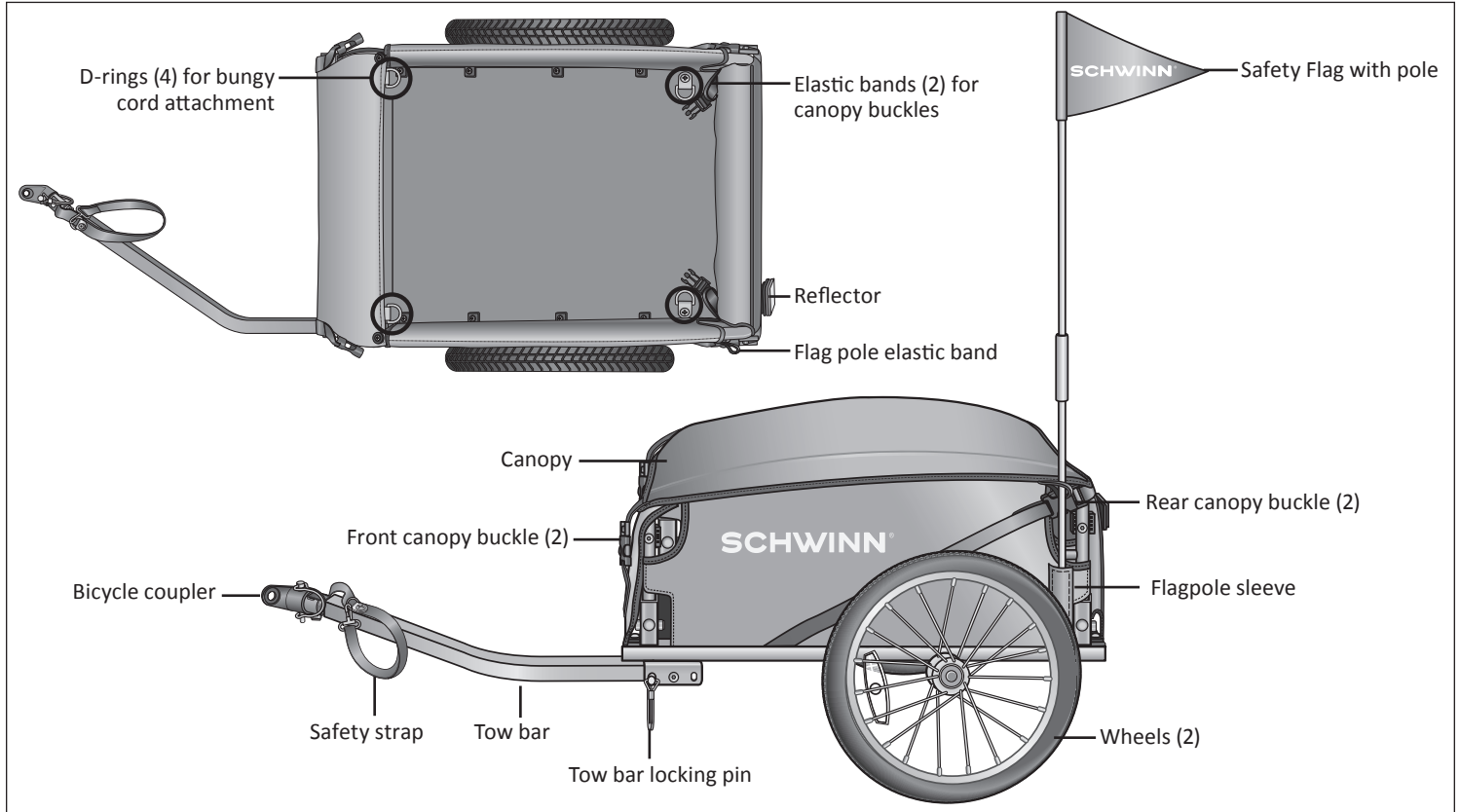

3 Assembly

EXTEND AND SECURE THE TOW BAR

⚠ WARNING!

- There are pinch points between the sidewalls and the frame of the trailer that may cause injury. Fold or unfold the trailer slowly using caution.
- Keep children clear when folding or unfolding the trailer.
- Ensure that all locking devices are engaged before use.

TIP! Start assembly with the tow bar side facing up.

- 1 Unlock the tow bar by removing the safety loop on the end of the locking pin. Remove the locking pin from the tow bar bracket. **Figure 3.1**
- 2 Rotate the tow bar out and away from the trailer. The tow bar should rest on the front of the frame. **Figure 3.1**

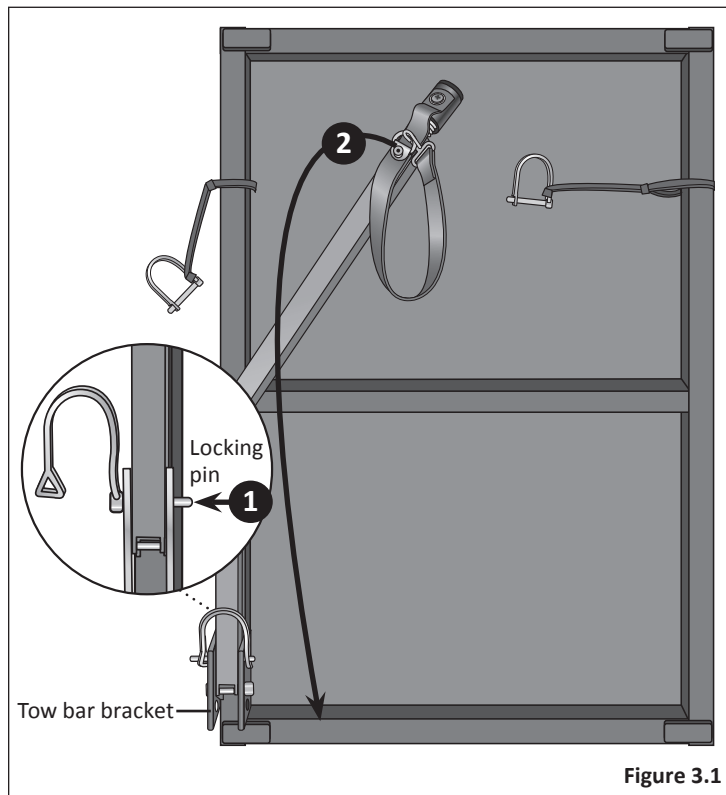
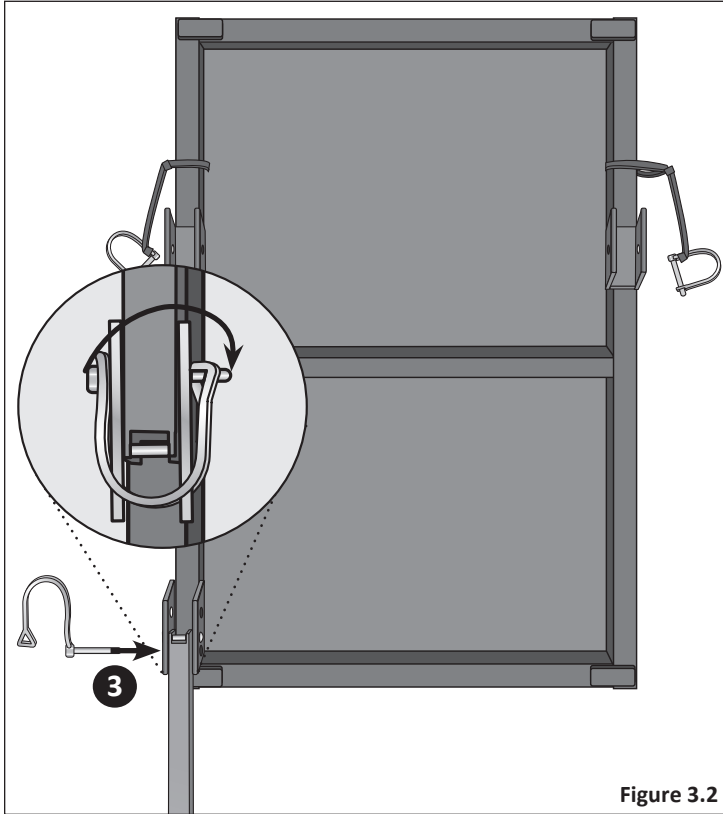

Figure 3.1

- 3 Re-insert the locking pin through the tow bracket, and lock it by inserting the end of the safety loop onto the end of the locking pin. **Figure 3.2**



ATTACH THE WHEELS

⚠ **WARNING!**

Wheels that are not securely locked in place may fall off the trailer and cause serious injury or death. Always check the wheels are securely locked in place before use.

- 1 Remove the caps from the ends of the wheels axles.
- 2 Insert the axle of the wheel completely into the hole located on the side of the wheel bracket. **Figure 3.3**

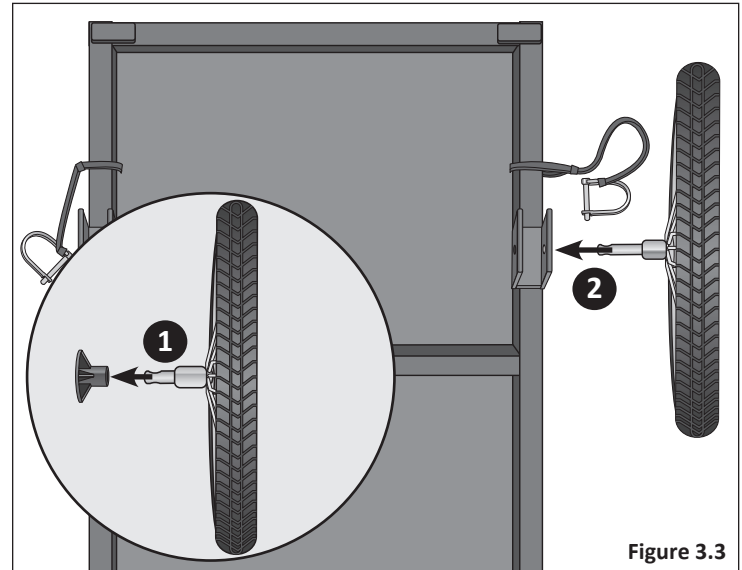

- 3** Insert the locking pin into the hole on the end of the axle and slide the end of the safety loop over the end of the locking pin. Check that the locking pin is securely in place. **Figure 3.4**

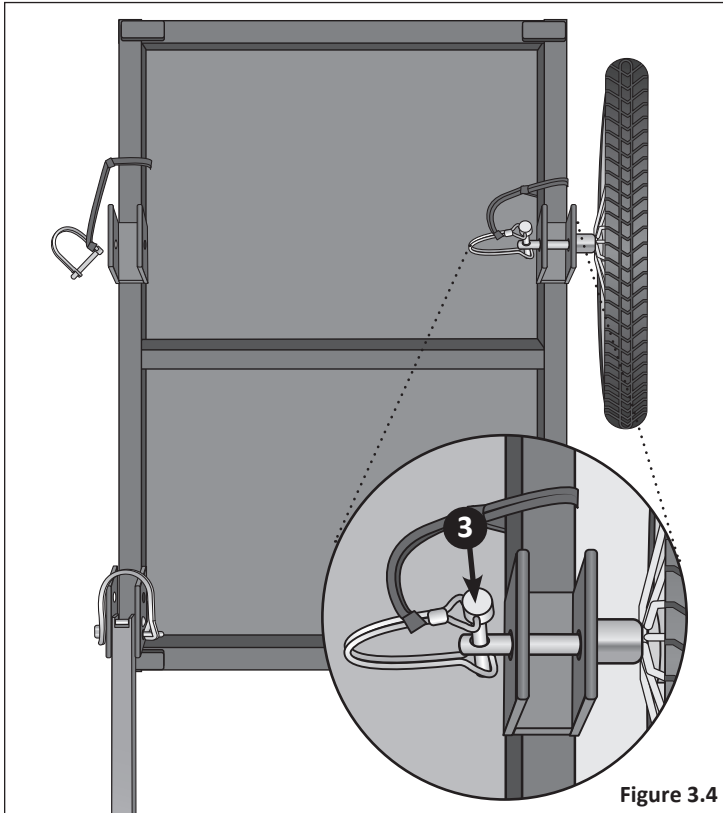

Figure 3.4

- 4** Repeat steps 2 and 3 for the remaining wheel. **Figure 3.5**

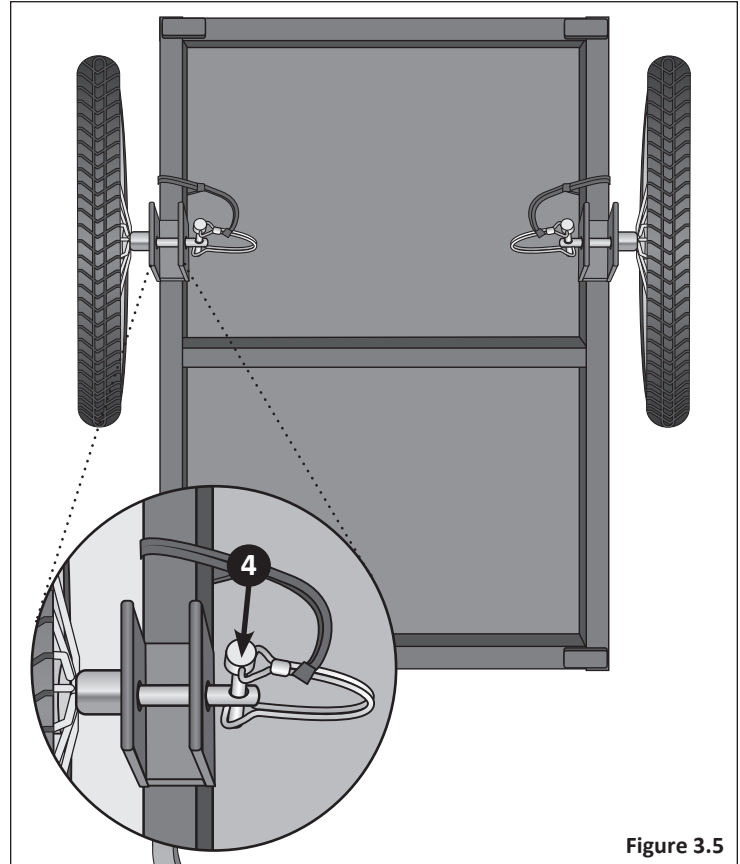

Figure 3.5

UNFOLD THE FRAME

⚠ WARNING!

- There are pinch points between the sidewalls and the frame of the trailer that may cause injury. Fold or unfold the trailer slowly using caution.
- Keep children clear when folding or unfolding the trailer.
- Ensure that all locking devices are engaged before use.

- 1 Holding the end of the tow bar, lift the tow bar and rotate the bar up and around until the trailer is right side up. **Figure 3.6**



Figure 3.6

- 2 Lift the **Right** side wall up into a vertical position. **Figure 3.7**

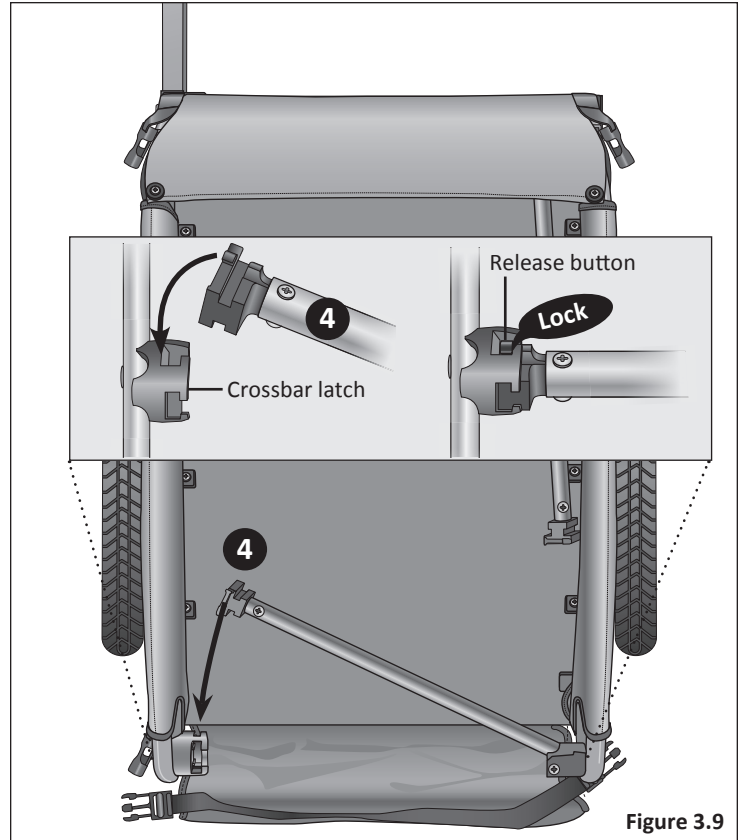

Figure 3.7

- 3 Lift the *left* side wall up into a vertical position. **Figure 3.8**



- 4 Rotate the back crossbar until it locks into the back crossbar latch. **Figure 3.9**



- 5 Rotate the front crossbar until it locks into the front crossbar latch. **Figure 3.10**

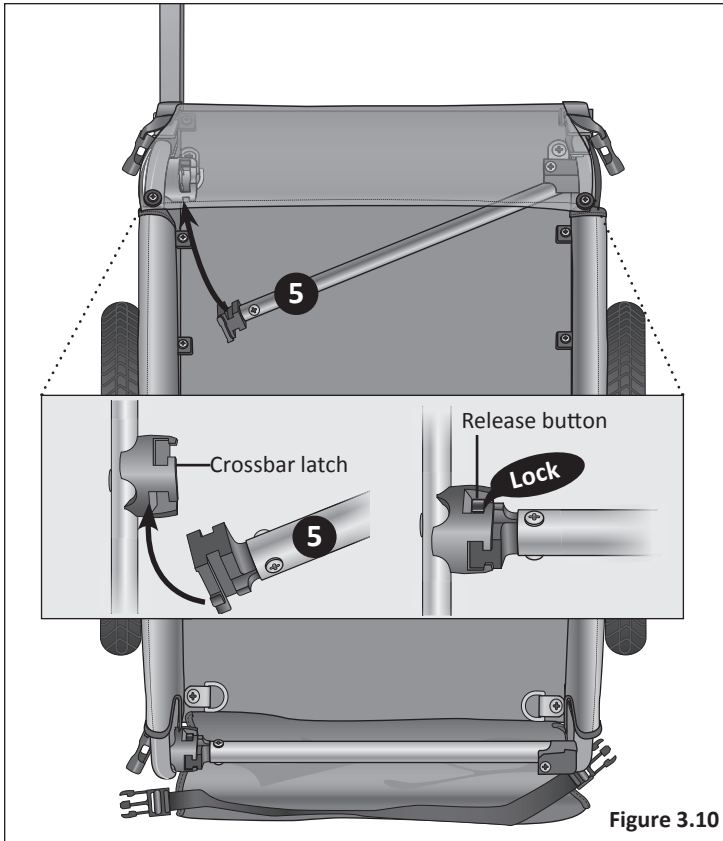

- 6 Pull the canopy over the back end of the trailer. **Figure 3.11**
- 7 Secure the canopy by fastening the buckles on the sides of the trailer. **Figure 3.11**

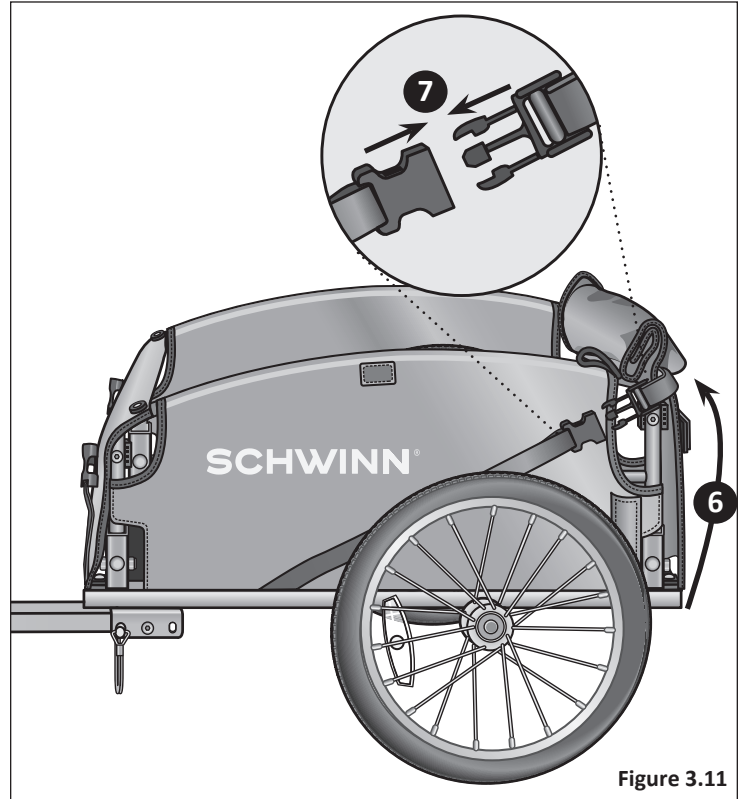

- 8 Fold the remaining section of the canopy over the back crossbar, and tuck the buckles of the canopy into the elastic bands inside the bottom corners of the trailer bed. **Figure 3.12**

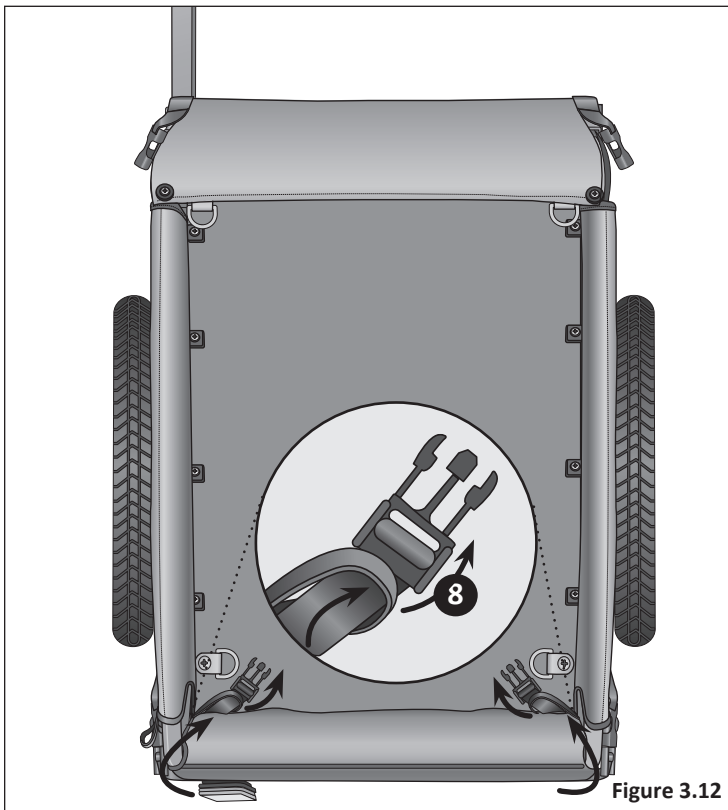

INSERT THE SAFETY FLAG

Important! The safety flag is an important safety feature that warns others that a trailer is present and on the bicycle. Always have the safety flag on the trailer when in use.

- 1 Insert the top half of the pole into the opening of the bottom half of the pole.
- 2 Insert the flag pole through the elastic loop on the back of the trailer and into the flag pole sleeve. **Figure 3.13**

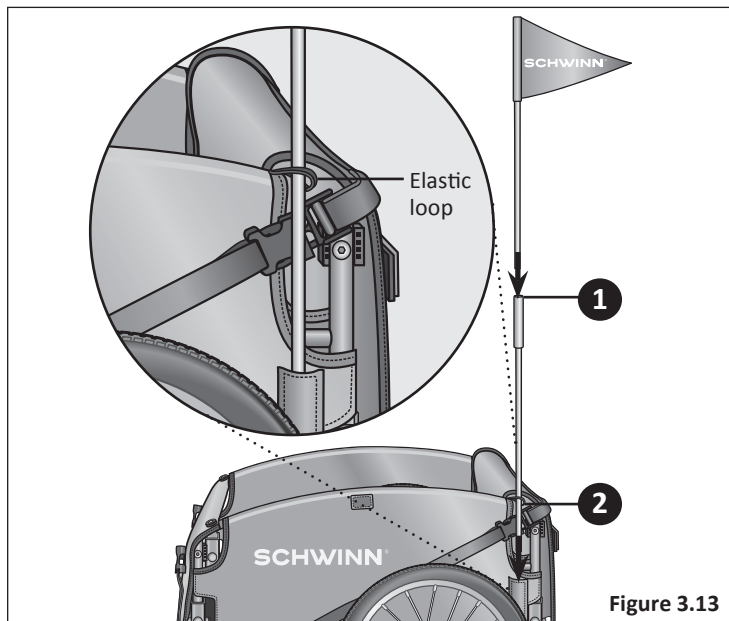

4 Trailer Attachment

⚠ WARNING!

Use of the trailer without the safety strap attached to the bicycle may result in serious injury or death. Always attach the safety strap to the bicycle when using the trailer.

Important! This section provides instructions for attaching the trailer coupler to the bicycle's REAR WHEEL with a hub nut or quick release lever. The coupler attaches to *most* bicycles.

- 1 To ensure secure attachment of the coupler to the bicycle, be sure the thread of the *rear axle* extends at least 2 mm's from the hub nut *before* proceeding to the next step. **Figure 4.1**
- 2 Using a wrench, remove the hub nut and washer from the bicycle's back wheel. **Figure 4.2**
- 3 Place the tab washer on the axle. Fit the tab into the slot on the bicycle frame dropout. Note: If your bicycle frame doesn't have a slot in the drop out, rotate the tab to fit into the axle slot. **Figure 4.3**

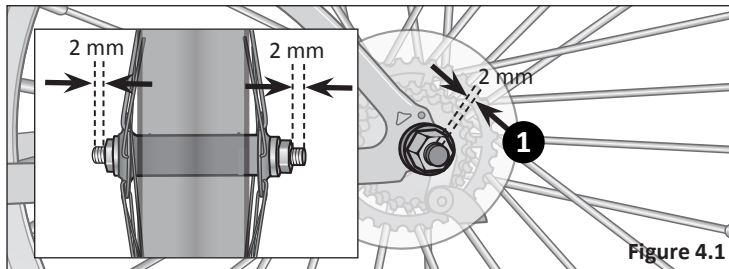

Figure 4.1

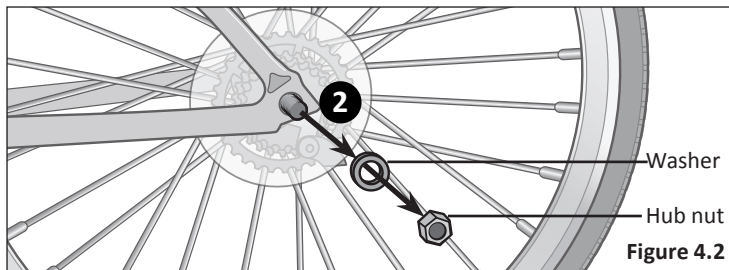

Figure 4.2

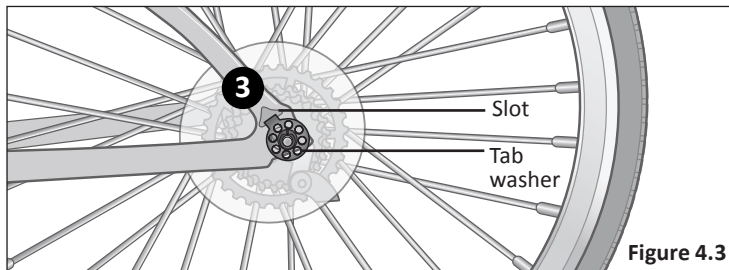
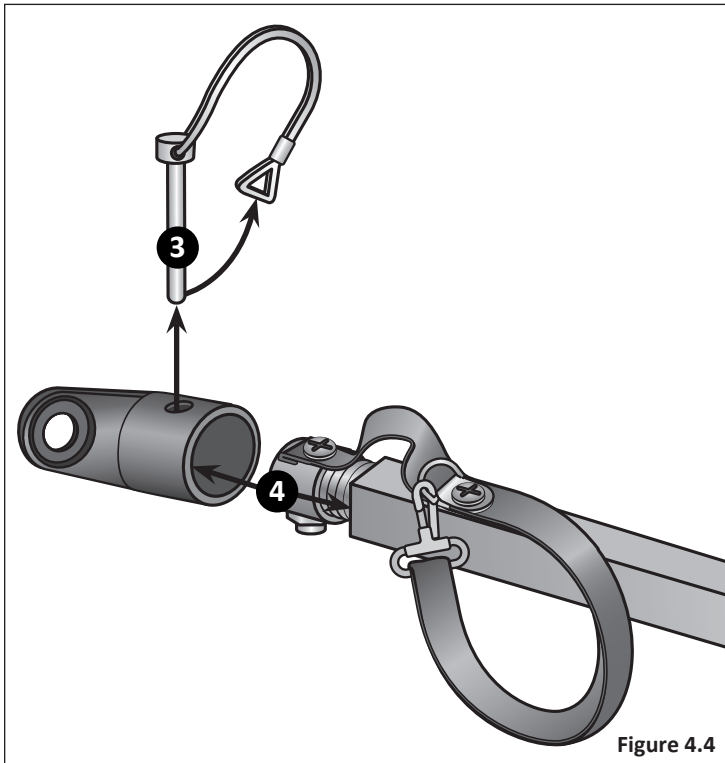
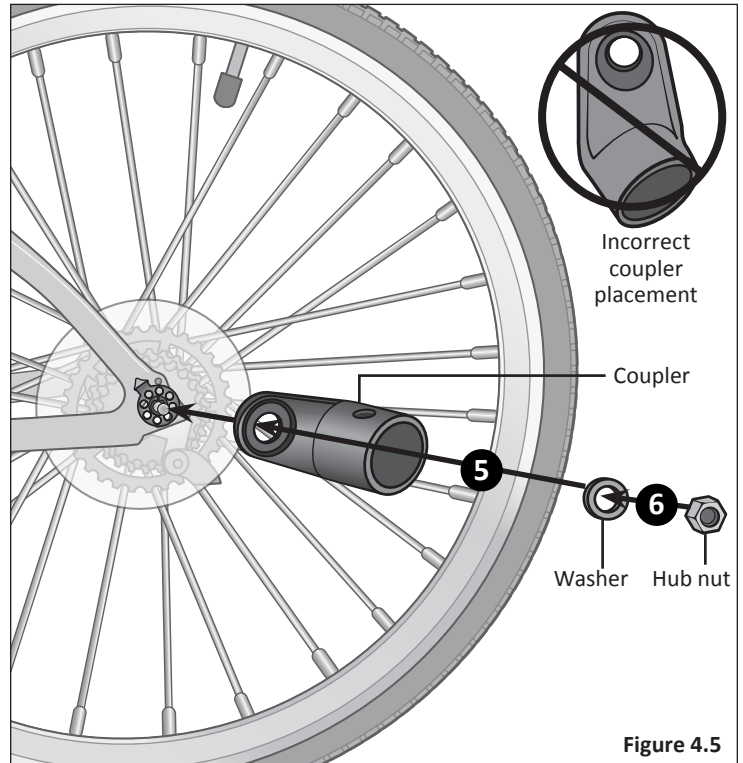

Figure 4.3

- 3 Remove the safety loop from the end of the locking pin on the end of the coupler. **Figure 4.4**
- 4 Remove the locking pin from the coupler and slide the coupler off the end of the tow bar.



- 5 Insert the coupler plate onto the wheel axle. Place the coupler in a horizontal position so that it is in line with the tow bar.
- 6 Place the hub nut and washer back onto the axle and tighten. **Figure 4.5**



- 7 Slide the tow bar into the open end of the coupler.

Important! Ensure the coupler is completely in line with the tow bar. This reduces stress on the tow bar.

- 8 Insert the locking pin into the hole on the top of the coupler. Slide the safety loop over the end of the lock pin.

Important! Ensure the loop of the safety pin is facing away from the wheel to prevent possible friction against the wheel and spokes of the bicycle. **Figure 4.6**

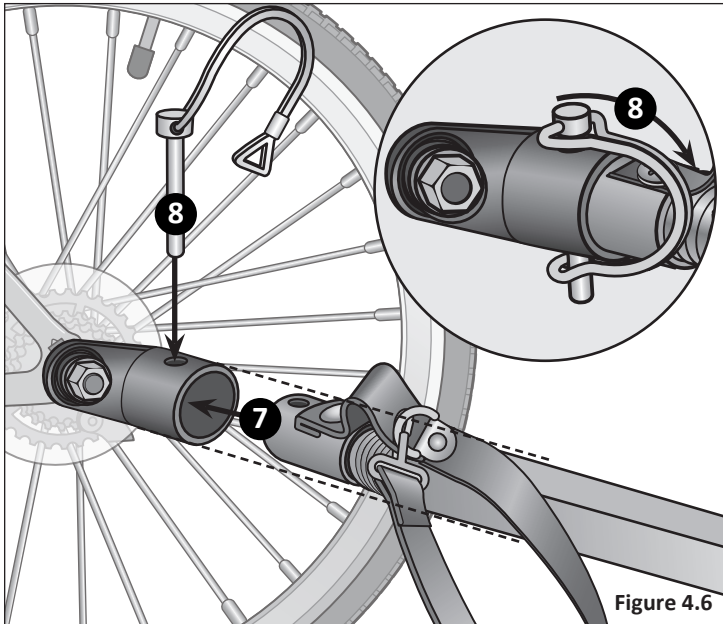

Figure 4.6

ATTACHMENT WITH QUICK RELEASE

- 1 Release the quick release lever, skewer and remove the nut and spring from the opposite side of the wheel.
- 2 Remove the axle skewer and spring. Leave the wheel in place.

Figure 4.7

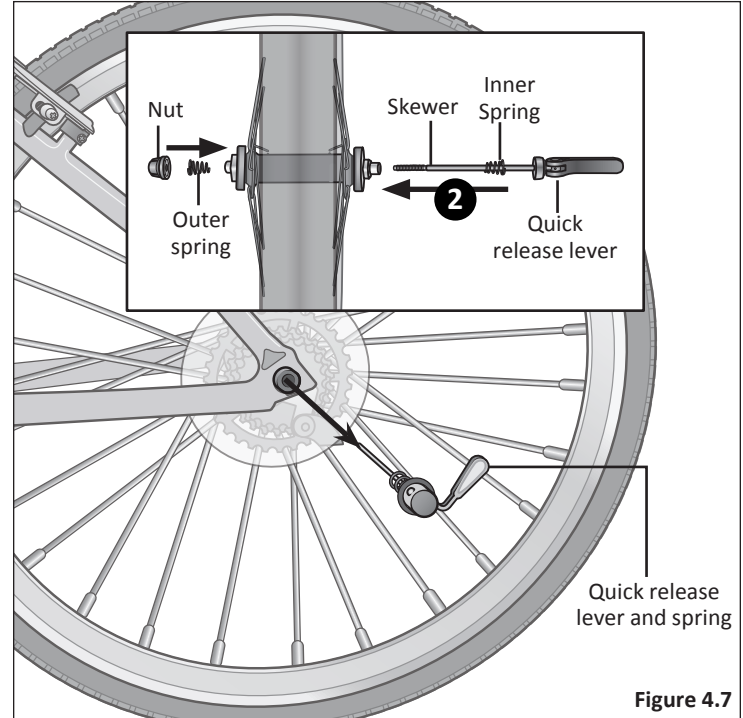

Figure 4.7

- 3 Place the tab washer on the axle. Fit the tab into the slot on the bicycle frame dropout. **Note:** If your bicycle frame doesn't have a slot in the drop out, rotate the tab to fit into the axle slot. **Figure 4.8**

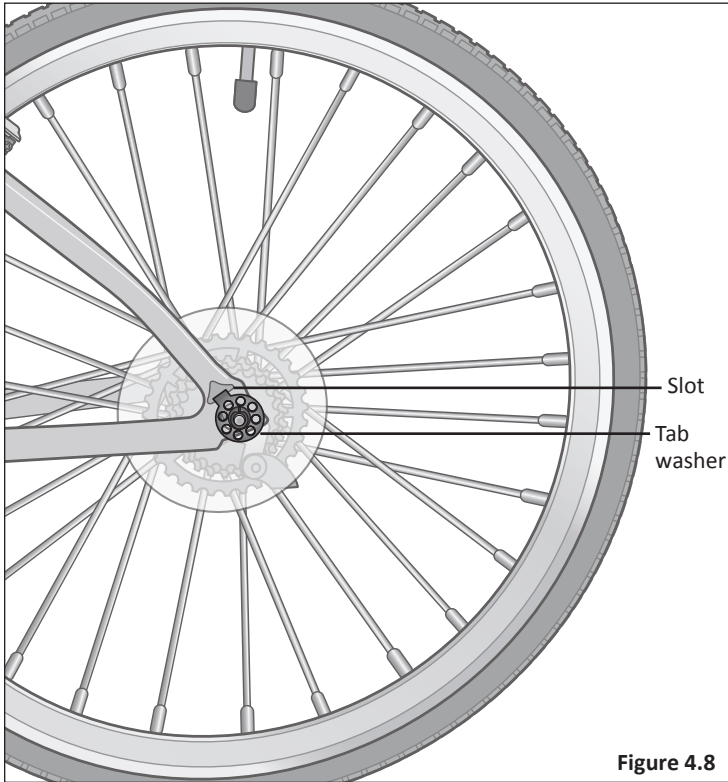

Figure 4.8

- 4 Insert the coupler plate onto the wheel axle. **Figure 4.9**
- 5 Insert the quick release lever, spring and nut that were removed in step 1 through the wheel.
- 6 Rotate the quick release lever up and tighten. When properly tightened, the quick release lever should leave an imprint in your hand. The pressure should be firm but not excessive.

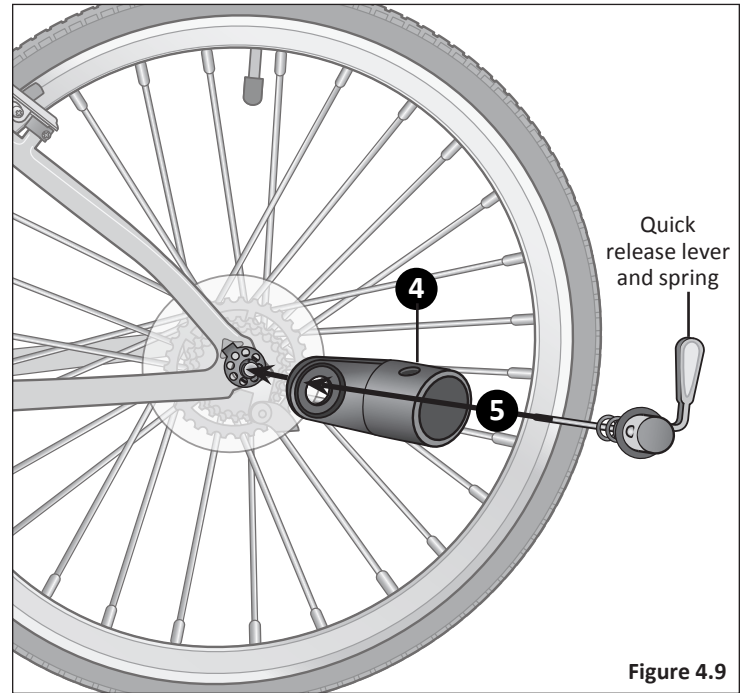
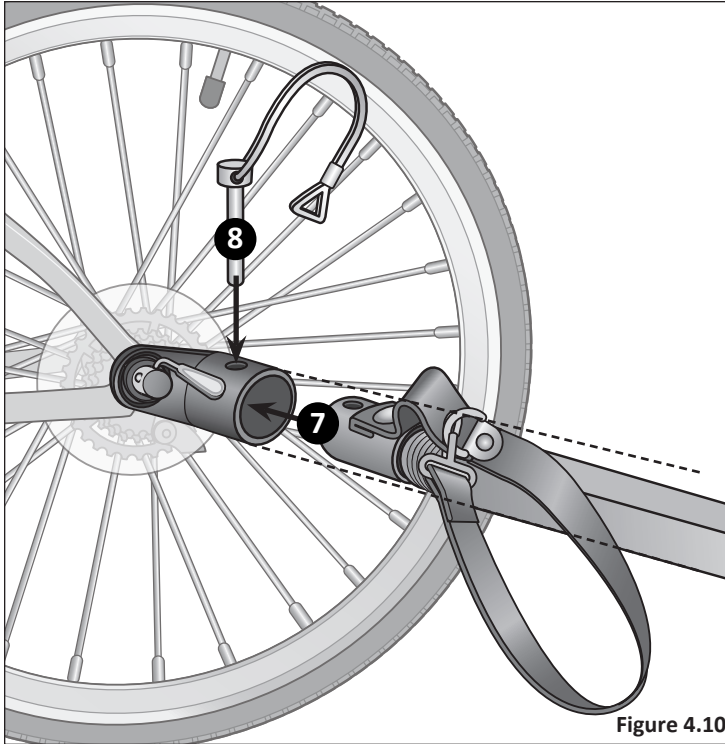

Figure 4.9

- 7 Slide the tow bar into the open end of the coupler.

Important! Ensure the coupler is completely in line with the tow bar. This reduces stress on the tow bar. **Figure 4.10**

- 8 Insert the locking pin into the hole on the top of the coupler.



- 9 Slide the safety loop over the end of the lock pin. **Figure 4.11**

Important! Ensure the loop of the safety pin is facing away from the wheel to prevent possible friction against the wheel and spokes of the bicycle.

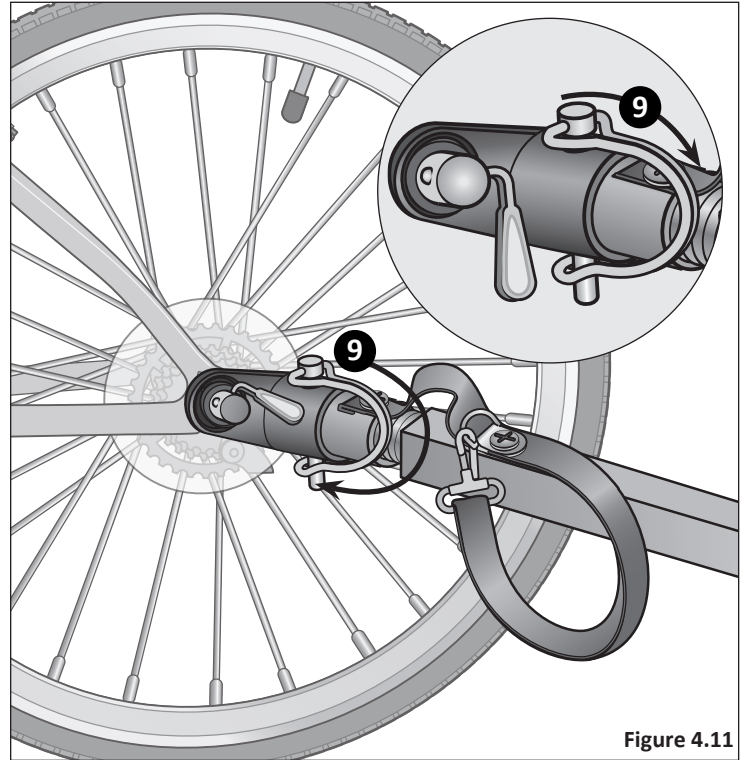

ATTACH THE SAFETY STRAP

⚠ WARNING!

Use of the trailer without the safety strap attached to the bicycle may result in serious injury or death. Always attach the tow bar safety strap to the bicycle when using the trailer.

- 1 Wrap the tow bar safety strap around the bicycle frame.
Figure 4.12

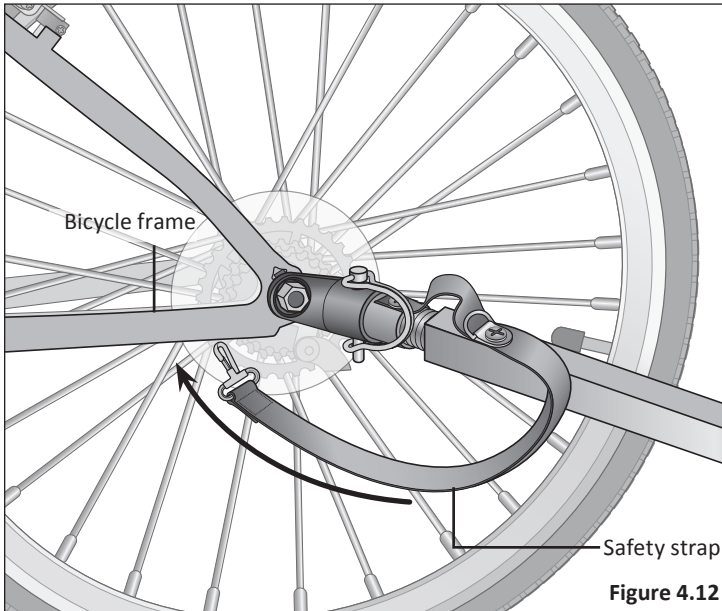

- 2 Clip the safety strap to the tow bar ring on the end of the tow bar. Be sure the tow bar safety strap is securely attached before using the trailer. Figure 4.13

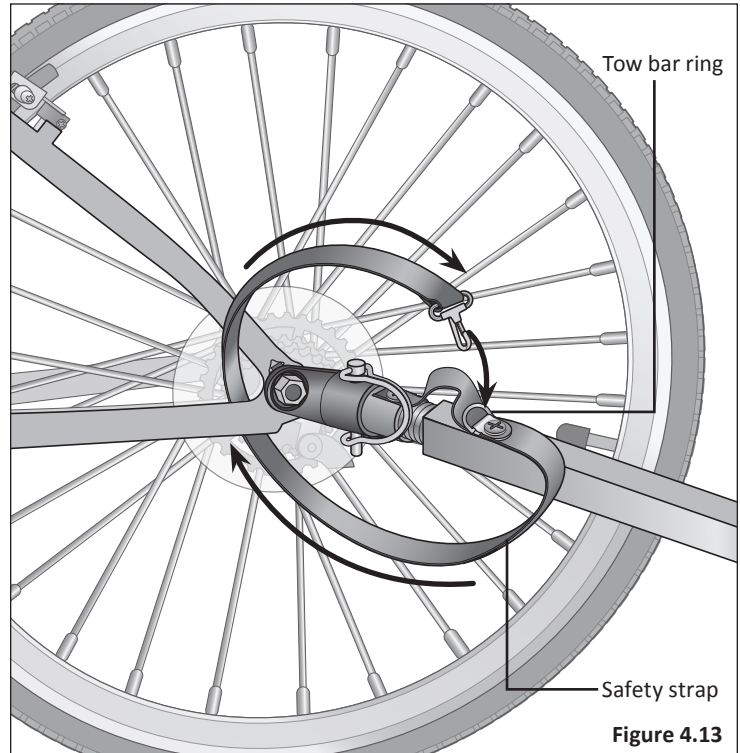

5 Using the Cargo Trailer

⚠ WARNING!

- Weight limit is 100 lbs. Do not carry loads exceeding 100 lbs, as the extra weight and height will increase the center of gravity, increasing the risk of tip over
- Do not carry items that exceed the trailer's frame by more than 8" (high). Carrying taller loads will increase the trailers center of gravity and increase the risk of tip over

We recommend:

- That loads do not extend past the back of the trailer's frame. This can create a hazard by interfering with the bicycle, ground, or other obstacles such as curbs, signs, cars, etc.)
- Storing the trailer inside after use. Inclement weather and harsh elements may stress the fabric on the trailer

- 1 **Load Limits:** loads should be no higher than 8" above the trailer top, and should not extend beyond the end of the trailer. **Figure 5.1**

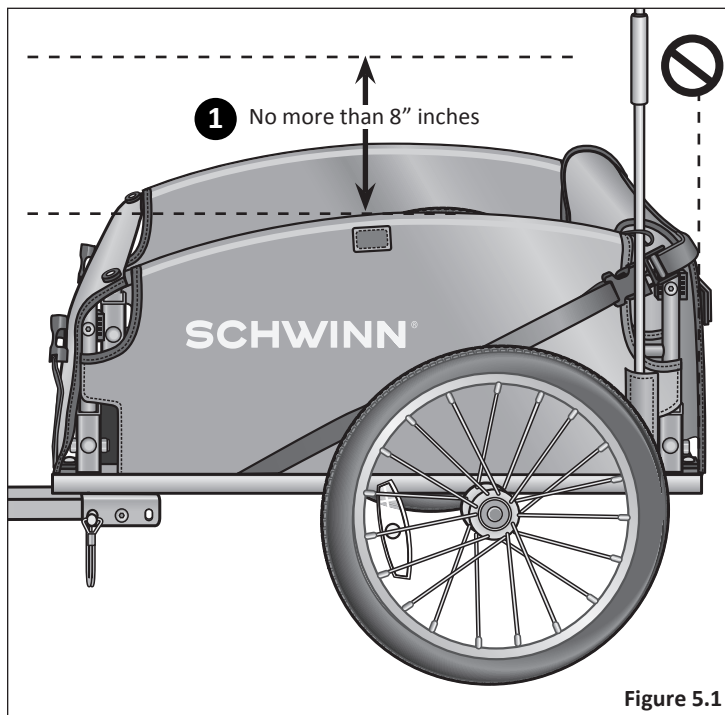
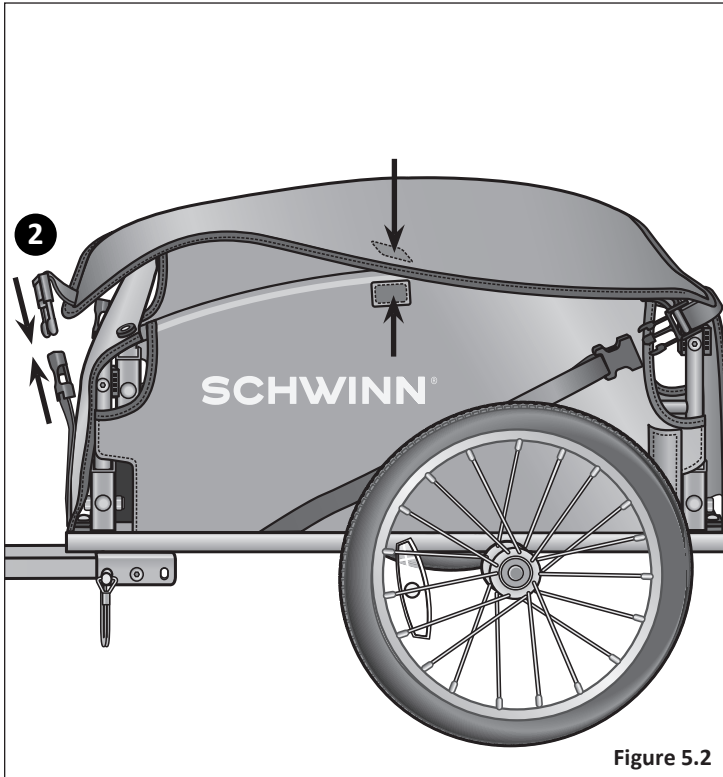

Figure 5.1

- 2 Canopy:** To attach the canopy, cover the top of the trailer with the canopy. Secure the canopy to the trailer frame by using the hook and loop and buckles on the front, top corners of the trailer. Note: The top canopy is not weather proof. **Figure 5.2**



- 3 D-rings:** To help secure your load, use the D-rings located on the bottom corners of the trailer bed for bungy cord attachment. **Figure 5.3**



6 Disassembly and Storage

⚠ WARNING!

- There are pinch points between the sidewalls and the frame of the trailer that may cause injury.
- Always fold or unfold the trailer slowly and with caution.
- Keep children clear when folding or unfolding the trailer.

- 1 Remove the flag pole and separate the flag pole sections. **Figure 6.1**

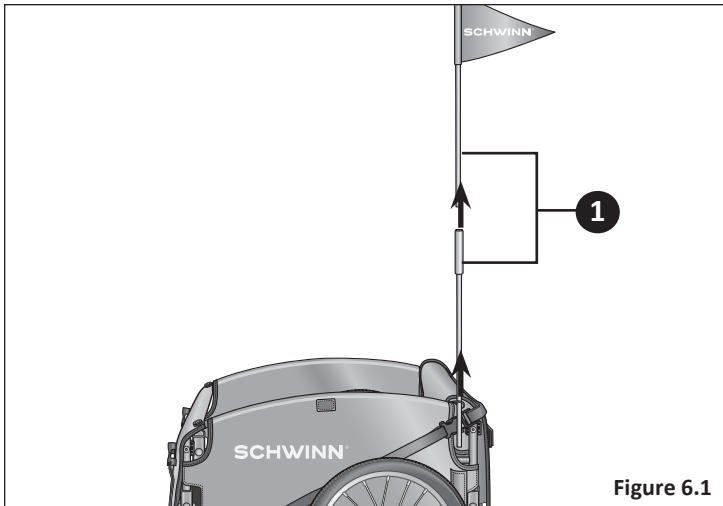

Figure 6.1

- 2 Release both crossbars by pressing the crossbar latch release buttons, and rotate the crossbars to the side walls. **Figure 6.2**

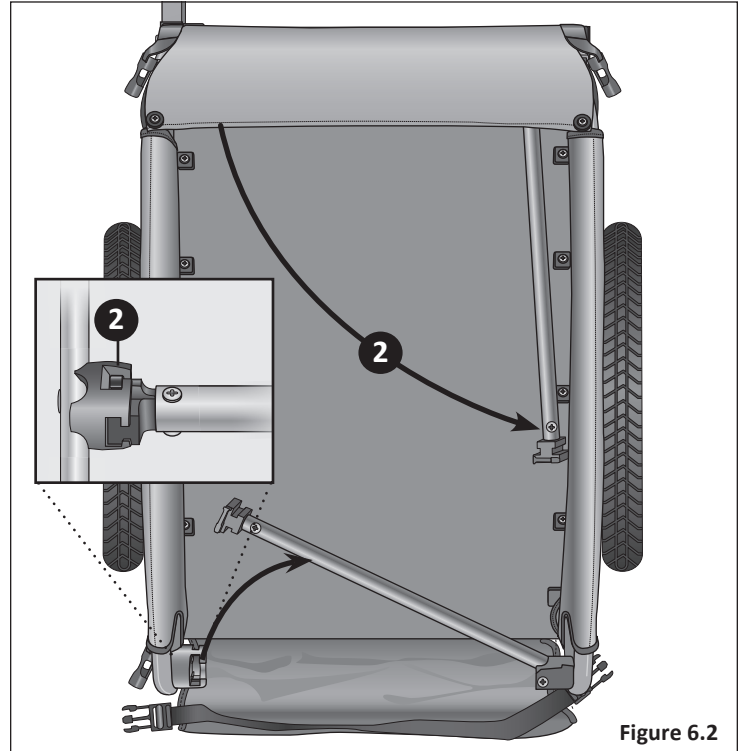
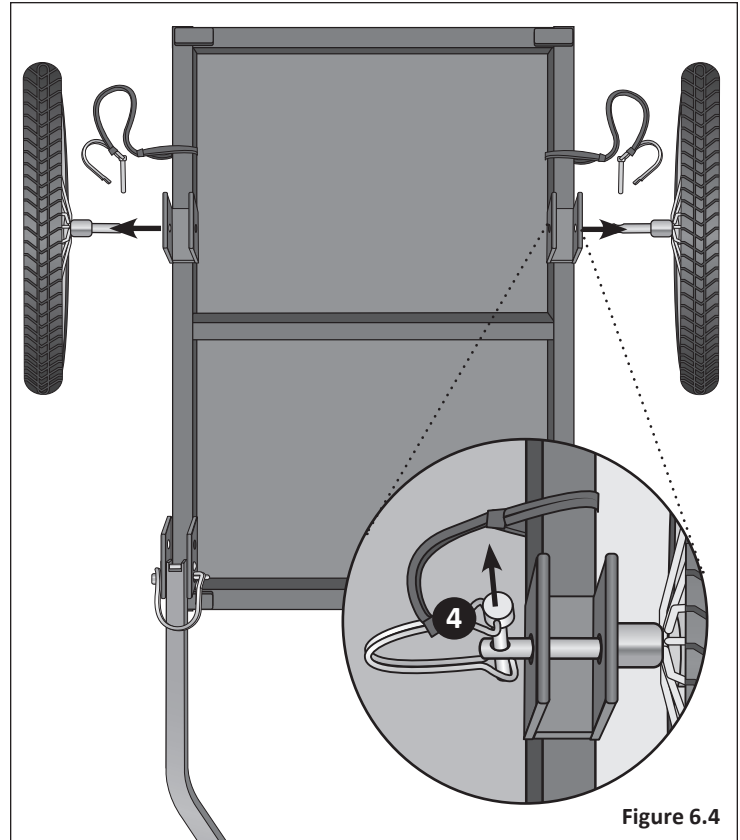

Figure 6.2

- 3 Fold the left and right side walls down. **Figure 6.3**



- 4 Remove the locking pins from the wheels. Pull the wheels out of the wheel brackets. **Figure 6.4**



- 5 Remove the locking pin from the tow bracket. **Figure 6.5**

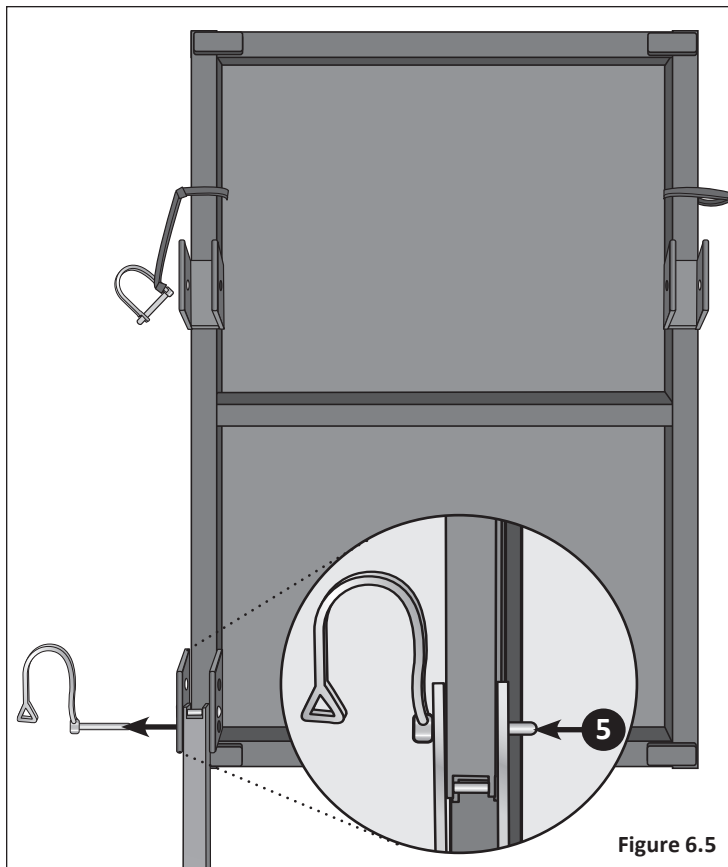

- 6 Rotate the tow bar back into the frame. Insert the locking pin through the tow bar and frame. Secure the safety loop over the end of the locking pin. **Figure 6.6**

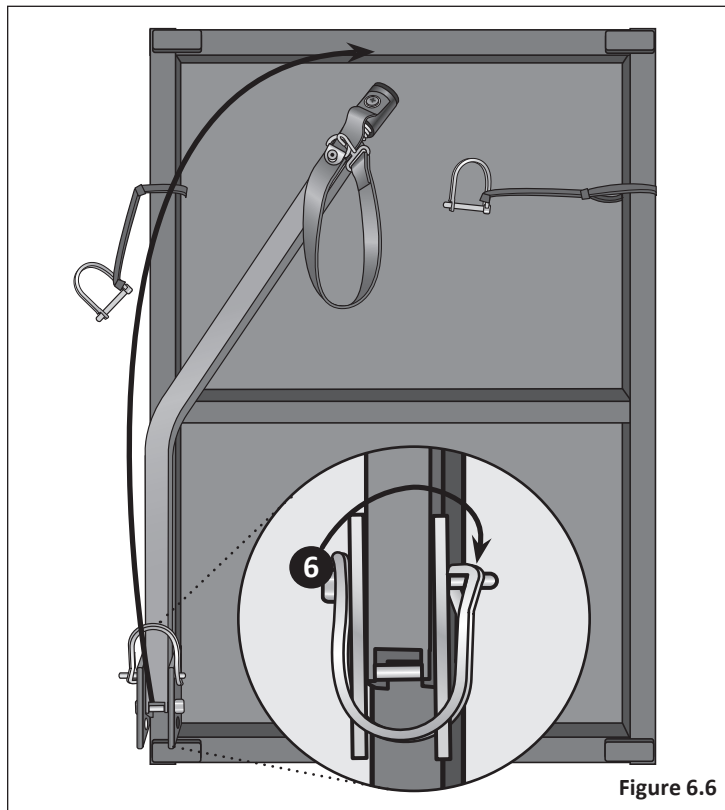

7 Maintenance and Parts

CARE

- **To clean the trailer:** use only mild soap and water. Do not use cleaning solvents.
- **Do not leave trailer outside after use.** Inclement weather and harsh elements may stress the fabric on the trailer
- **Routinely check** that all fasteners and equipment (wheels, reflectors, flag, etc) are tight and properly assembled.
- **Check the tire pressure often.** The recommended tire pressure range is printed on the tire. Only use a foot or hand pump to inflate.
- **Have a qualified bicycle mechanic** perform routine safety checks on your bicycle before using with the trailer.
- **Routine bicycle maintenance** is recommended to be performed every year.

ACCESSORIES

- 1pc Trailer Coupler
- 1pc Tab Washer
- 1pc Locking Pin

Please direct any accessory (small parts) and warranty inquiries to Pacific Cycle Customer Service at **1-800-242-6110**.

8 Warranty

Pacific Cycle warrants this product to be free of defective materials and workmanship for 1 year from the date of original purchase.

THIS LIMITED WARRANTY IS THE ONLY WARRANTY APPLICABLE TO THIS PRODUCT, AND IS EXPRESSLY IN LIEU OF ANY OTHER WARRANTY. This limited warranty gives you specific legal rights and you may also have other rights which may vary from state to state.

This warranty is extended only to the original consumer purchaser for non-commercial use and does not cover tires or tubes, or other wear parts, ordinary wear and tear, abuse, misuse, neglect, theft, or damage due to accident.

PACIFIC CYCLE IS NOT RESPONSIBLE FOR INCIDENTAL OR CONSEQUENTIAL DAMAGES. THIS LIMITED WARRANTY DOES NOT COVER ANY PERSONAL INJURIES, DAMAGE TO, OR, FAILURE OF THE PRODUCT OR ANY OTHER LOSSES DUE TO ACCIDENT, ABUSE, MISUSE, ALTERATION, NEGLIGENCE, NORMAL WEAR AND TEAR, IMPROPER ASSEMBLY, IMPROPER FIT, IMPROPER MAINTENANCE OR USE OF UNAUTHORIZED REPLACEMENT PARTS NOT DESIGNED FOR THE PRODUCT.

To make a claim under warranty, notification of such defect must be given to Pacific Cycle, Inc. at 1-800-242-6110. You will be instructed on how the product or part needing replacement should be shipped, postpaid, to Pacific Cycle, Inc.

SCHWINN®

Manufactured for Pacific Cycle, Inc (A Division of Dorel Industries)

Pacific Cycle, Inc.
4902 Hammersley Road
Madison, WI 53711

©2016 Pacific Cycle, Inc.

Schwinn® is a registered trademark of Pacific Cycle, Inc.

Made in China · Printed 2016