



# Power Trackbarrow

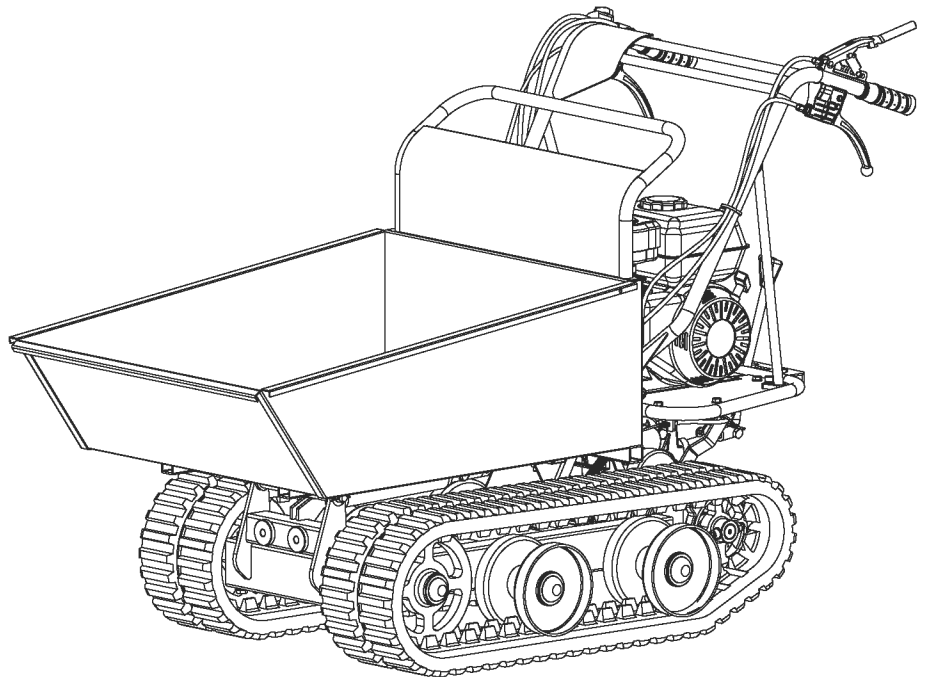
Operator's Manual

**MODEL NUMBER**  
YD8103

**SERIAL NUMBER**

**PURCHASE DATE**

Both model number and serial number may be found on the main label. (See **Page 2, Figure 1**) You should record both of them in a safe place for future use.



---

**FOR YOUR SAFETY**

**READ AND UNDERSTAND THE ENTIRE MANUAL BEFORE OPERATING MACHINE**

---

Your new YARDMAX® power trackbarrow offers quality construction, and is easy and safe to operate. With proper use and care, it is designed to give you many years of dependable service.

Take on any job with ease, portability, and convenience while experiencing the durability of your new power trackbarrow!

### Discover the YARDMAX Advantage

At YARDMAX, we understand that land ownership definitely has its privileges, but it also comes with a great deal of responsibility. When duty calls and you need to respond, will you have what it takes to tame the great outdoors?

When looking for outdoor power equipment (OPE) to get the job done right, at the right price, YARDMAX delivers the perfect combination of performance and practicality. YARDMAX has a solution that's right for you.

### MAX Performance, MAX Value, MAX Support – that's YARDMAX

- ✓ Backed by decades of proven manufacturing expertise
- ✓ Enhanced design features come standard
- ✓ Engineered for the best user experience
- ✓ Quality metal parts are used instead of plastic
- ✓ A robust warranty supports all products
- ✓ Budget-friendly prices make it practical



*Up for the job? YARDMAX is.*

---

## TABLE OF CONTENTS

---

Introduction	1	Know Your Machine	11
Specifications	3	Operation	13
Symbols	4	Maintenance	15
Safety	5	Storage	19
Unpacking the Container	7	Troubleshooting	20
Contents Supplied	8	Parts Diagram	21
Assembly of Optional Accessories	9	Parts List	23



Carefully read through this entire operator's manual before using your new unit. Pay attention to all cautions and warnings.

This machine is a gasoline engine driven power trackbarrow. It is a durable, versatile and efficient machine, and it is both easy and safe to operate. With proper use and care, it should give you many years of dependable service.

### ENGINE MANUAL

The **Engine Manufacturer** is responsible for all engine-related issues regarding performance, power rating, specifications, warranty and service. Please refer to the **Engine Manufacturer's** owner/operator's manual, packed separately with your unit, for more information.

### EMISSION CONTROL SYSTEM

This equipment or its engine may include exhaust and evaporative emission control system components required to meet U.S. Environmental Protection Agency (EPA) and/or California Air Resources Board (CARB) regulations. Tampering with emission controls and components by unauthorized personnel may result in severe fines or penalties. Emission controls and components can only be adjusted by an authorized engine manufacturer's service center.

### CALIFORNIA PROPOSITION 65 WARNING

Engine exhaust, some of its constituents and certain product components contain or emit chemicals known to the state of California to cause cancer and birth defects or other reproductive harm. For more information, go to [www.P65Warnings.ca.gov](http://www.P65Warnings.ca.gov).

### ENVIRONMENTAL



Recycle unwanted materials instead of disposing of them as waste. All tools, hoses, and packaging should be taken to the local recycling center and disposed of in an environmentally safe way.

### MODEL AND SERIAL NUMBERS

For future reference, record both the model number (see **Figure 1, Illustration a**) and the serial number (see **Figure 1, Illustration b**), as well as date and place of purchase. Have this information available when ordering parts, optional accessories and when making technical or warranty inquiries.

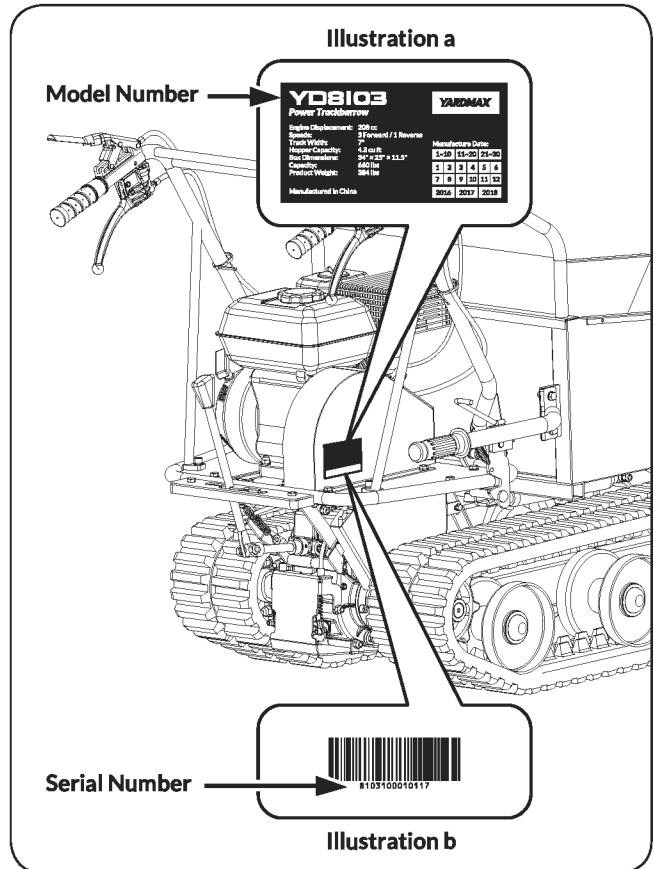


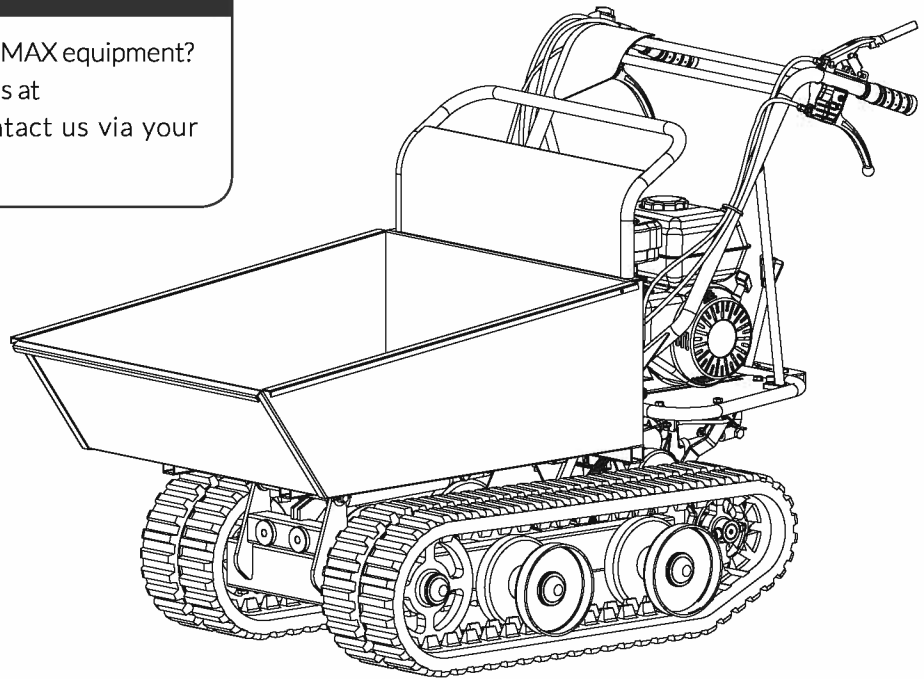
Figure 1

### DISCLAIMER

YARDMAX reserves the right to discontinue, change, and improve its products at any time without notice or obligation to the purchaser. The descriptions and specifications contained in this manual were in effect at printing. Equipment described within this manual may be optional. Some illustrations may not be applicable to your unit.

## SUPPORT

Have questions about your YARDMAX equipment?  
Call us at 844-YARDMAX, email us at  
support@yardmax.com, or contact us via your  
favorite social media site.



## SPECIFICATIONS

Model Number	YD8103
Engine	Briggs & Stratton
Displacement	208 cc
Start Type	Recoil
Load Capacity	660 lbs
Hopper Capacity	4.3 cu ft
Speeds	3 Forward / 1 Reverse
Track Width	7"
Box Dimensions (L x W x H)	34" x 25" x 11.5"
Hydraulic	No
Zero Turn Radius	Yes
Product Weight	384 lbs

## SYMBOLS

The rating plate on your machine may show symbols. These represent important information about the product or instructions on its use.



Read these instructions carefully.



Wear eye protection.



Wear protective gloves.



Wear safety footwear.



Do not remove or tamper with the protection and safety devices.



No smoking, sparks, or flames.



Do not touch parts that are hot from operation. Serious burns may result.



Keep your hands clear from all rotating parts.



Never start or run the engine inside a closed area.



Do not operate on slopes with angle over 20° or tip loading at an inclined position.



Be aware, objects may be thrown while in use.



The exhaust fumes are dangerous, containing carbon monoxide. Staying in the environment can lead to unconsciousness and death.



Always turn off the engine before starting maintenance.



Keep children and bystanders off and away.

---

# SAFETY

---

## GENERAL SAFETY RULES

### UNDERSTAND YOUR MACHINE

Read this manual and labels affixed to the machine to understand its limitations and potential hazards.

Be thoroughly familiar with the controls and their proper operation. Know how to stop the machine and disengage the controls quickly.

Make sure to read and understand all the instructions and safety precautions as outlined in the **Engine Manufacturer's** manual packed separately with your unit. Do not attempt to operate the machine until you fully understand how to properly operate and maintain the engine and know how to avoid accidental injuries and/or property damage.

If the unit is to be used by someone other than original purchaser, or is to be loaned, rented, or sold, always provide this manual and any needed safety training before operation. The user can prevent and is responsible for accidents or injuries that may occur to themselves, to other people, or to property.

Do not force the machine beyond its limits. Use the correct machine for your application.

### PERSONAL SAFETY

Do not permit children to operate this machine at any time.

Keep children, pets, and other people not using the unit away from the work area. Be alert and shut off the unit if anyone enters work area. Keep children under the watchful care of a responsible adult.

Do not operate the machine while under the influence of drugs, alcohol, or any medication that could affect your ability to use it properly.

Dress properly: Wear long, heavy pants, work boots, and work gloves. Do not wear loose clothing, short pants, or jewelry of any kind. Secure long hair so it is above shoulder level. Keep your hair, clothing, and gloves away from moving parts. Loose clothes, jewelry, or long hair can be caught in moving parts.

Protect eyes, face, and head from objects that may be thrown from the unit. Always wear safety goggles or safety glasses with side shields when operating.

Wear appropriate hearing protection.

Always keep hands and feet away from all moving parts during operation. Moving parts can cut or crush body parts.

Always keep hands and feet away from all pinch points.

Do not touch parts that might be hot from operation. Allow parts to cool before attempting to maintain, adjust, or service.

Stay alert, watch what you are doing, and use common sense when operating the machine.

Do not overreach. Do not operate the machine while barefoot or when wearing sandals or similar lightweight footwear. Wear protective footwear that will protect your feet and improve your footing on slippery surfaces. Keep proper footing and balance at all times. This enables better control of the machine in unexpected situations.

### INSPECT YOUR MACHINE

Check your machine before starting it. Keep guards in place and in working order. Make sure all nuts, bolts, etc., are securely tightened.

Never operate the machine when it is in need of repair or is in poor mechanical condition. Replace damaged, missing, or failed parts before using it. Check for fuel leaks. Keep the machine in safe working condition.

Do not use the machine if the engine's switch does not turn off the engine when running. Any gasoline powered machine that can't be controlled with the engine switch is dangerous and must be replaced.

Regularly check to see that keys and adjusting wrenches are removed from the machine area before starting it. A wrench or a key that is left attached to a rotating part of the machine may result in personal injury.

Avoid accidental starting. Be sure the engine's switch is off before transporting the machine or performing any maintenance or service on the unit. Transporting or performing maintenance or service on a machine with its switch on invites accidents.

If the machine should start to vibrate abnormally, stop the engine (motor) and check immediately for the cause. Vibration is generally a warning sign of trouble.

### ENGINE SAFETY

This machine is equipped with an internal combustion engine. Do not use on, or near, forest-covered or brush-covered land unless the exhaust system is equipped with a spark arrester meeting applicable local, state, or federal laws.

In the state of California, a spark arrester is required by law. Other states have similar laws. A spark arrester, if used, must be maintained in effective working order by the operator.

Never start or run the engine inside a closed area. The exhaust fumes are dangerous, containing carbon monoxide, an odorless and deadly gas. Operate this unit only in a well-ventilated outdoor area.

Do not tamper with the engine in an effort to get it to run at higher speeds. The maximum engine speed is preset by the manufacturer and is within safety limits. See engine manual.

Keep a Class B fire extinguisher on hand when operating this machine in dry areas as a precautionary measure.

### FUEL SAFETY

Fuel is highly flammable, and its vapors can explode if ignited. Take precautions when using to reduce the chance of serious personal injury.

When refilling or draining the fuel tank, use an approved fuel storage container while in a clean, well-ventilated outdoor area. While adding fuel or operating the unit, do not smoke, and stay away from sparks, open flames, or other sources of ignition near the area of operation. Never fill the fuel tank indoors.

To avoid sparking or arcing, keep grounded conductive objects – such as tools – away from exposed, live electrical parts and connections. These events could ignite fumes or vapors.

Always stop the engine and allow it to cool before filling the fuel tank. Never remove the cap of the fuel tank or add fuel while the engine is running or when the engine is hot. Do not operate the machine with known leaks in the fuel system.

Loosen the fuel tank cap slowly to relieve any pressure in the tank.

Never overfill the fuel tank. Because engine heat can cause fuel to expand, never fill the tank to more than 1/2" below the bottom of the filler neck. This will provide space for fuel expansion.

Replace all fuel tank and container caps securely and wipe up spilled fuel. Never operate the unit without the fuel cap securely in place.

Avoid creating a source of ignition for spilled fuel. If fuel is spilled, do not attempt to start the engine. Instead, move the machine away from the area of spillage and avoid creating any source of ignition until fuel vapors have dissipated.

When fuel is spilled on yourself or your clothes, wash your skin and change clothes immediately.

Store fuel in containers specifically designed and approved for fuel storage.

Store fuel in a cool, well-ventilated area, safely away from sparks, open flames, or other sources of ignition.

Never store fuel – or a machine with fuel in the tank – inside a building where fumes may reach a spark, open flame, or any other source of ignition (such as a water heater, furnace, or clothes dryer). Allow the engine to cool before storing in any enclosure.

## SPECIFIC SAFETY RULES

Thoroughly inspect the area to be worked. Keep the working area clean and free of debris to prevent tripping. Operate on flat, level ground.

Never place any part of your body where it would be in danger if movement should occur during assembly, installation, operation, maintenance, repair, or relocation.

Keep all bystanders, children, and pets at least 75 feet (23m) away. If you are approached, stop the unit immediately.

Do not mount anything on the hopper and never carry passengers.

Never park the machine in a place with unstable ground that could give way, particularly when it is full.

Disengage clutch lever before starting the engine.

Start the engine carefully according to instructions and with feet away from the moving parts.

Never leave the operating position when the engine is running.

Always hold the unit with both hands when operating. Keep a firm grip on the handlebars. Be aware that the machine may unexpectedly bounce upward or jump forward if the machine should strike buried obstacles such as large rocks or roots.

Walk, never run with the machine.

Do not overload the machine capacity. Always drive at a safe  
YD8103PM04 - 1811

speed, and adjust the speed to the slope of the land, the surface conditions of the road, and the weight of the load.

Use extreme caution when in reverse or pulling the machine towards you.

Exercise extreme caution when operating on or crossing gravel drives, walks, or roads. Stay alert for hidden hazards or traffic.

On soft ground, drive at the first forward/reverse gear. Do not rapidly accelerate, turn sharply or stop.

Pay the utmost attention when working on frozen ground, as the machine may tend to skid.

**Do not operate the machine in confined areas where there may be a risk of crushing the operator between the machine and another object.**

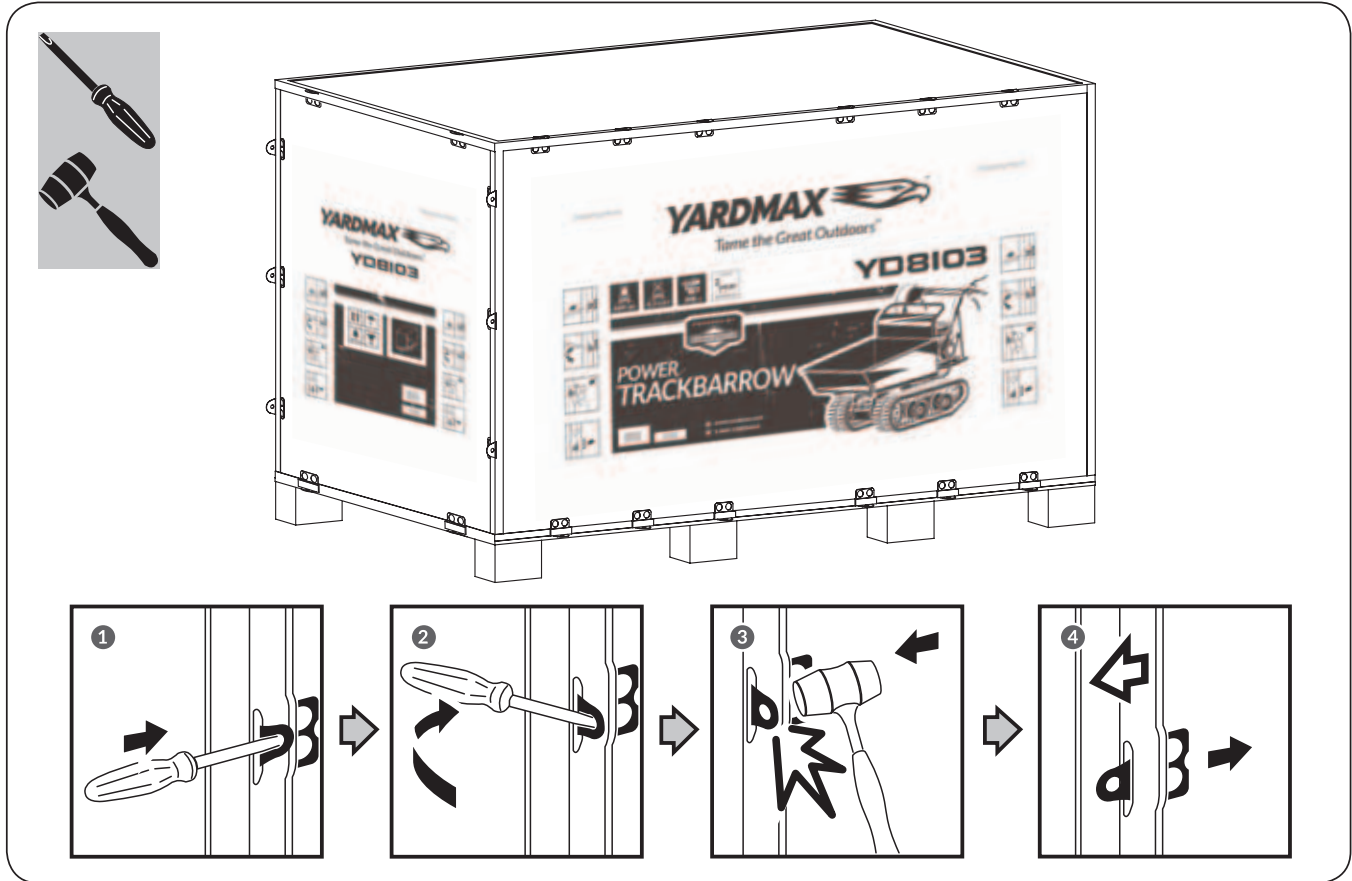
Never operate the machine on slopes where angle is over 20°.

When operating on a slope, whether moving forward or in reverse, always make certain that the weight is evenly balanced. Always operate the machine straight up or down slopes, never drive sideways or across the slope. Do not shift gears on slopes.

When dumping the contents of the hopper, the center of gravity will change continuously and the ground conditions will be essential for the stability of the machine. Use extra caution and control when dumping the hopper on unstable ground, such as wet clay or soil.

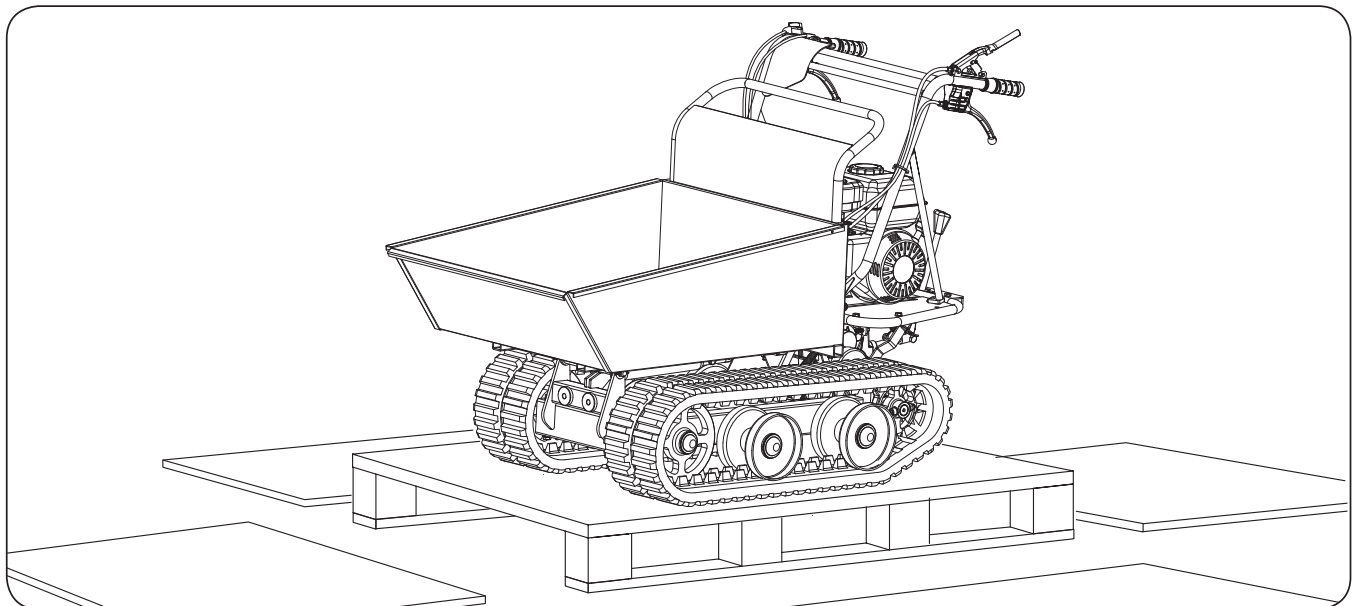
## UNPACKING THE CONTAINER

Use the screwdriver and hammer to open all the side locks. (See **Figure 1a**)



**Figure 1a**

Remove all the plywood plates (**Figure 1b**), and remove all the loose parts on the bottom pallets.

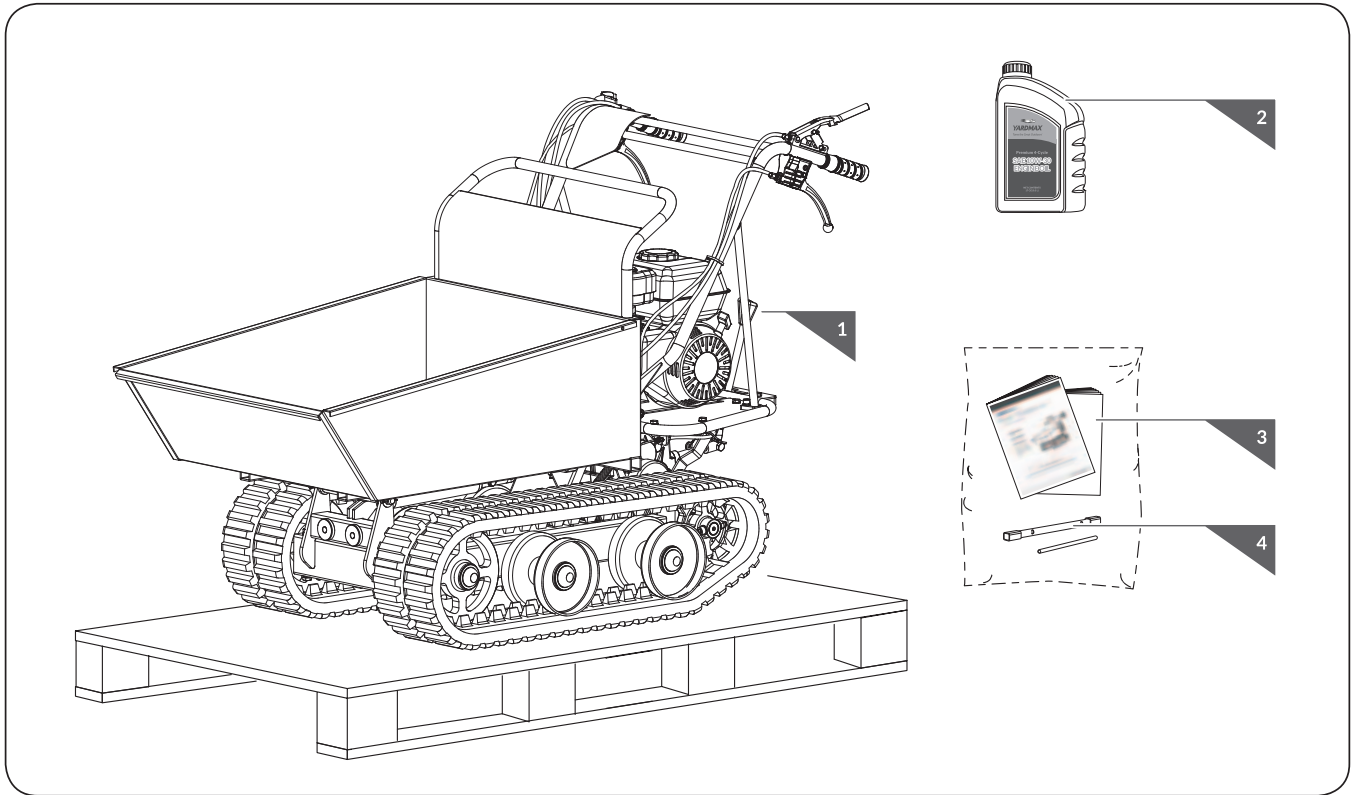


**Figure 1b**



## CONTENTS SUPPLIED

Your YARDMAX power trackbarrow comes partially assembled, and the package contains the following:



- 1. Machine
- 2. Engine Oil

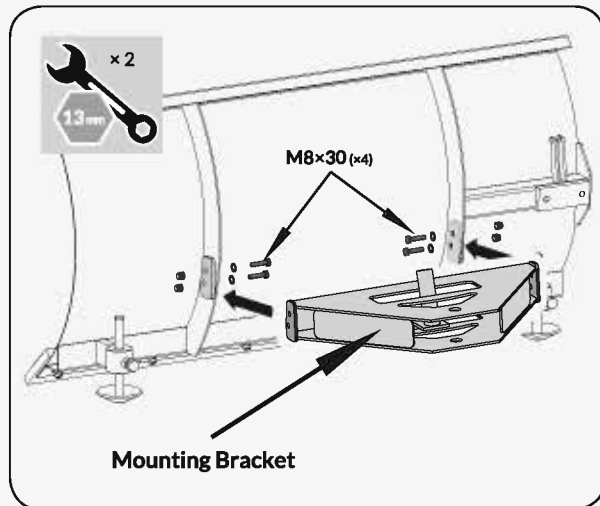
- 3. Operator's Manual & Engine Manual
- 4. Tools for Spark Plug Assembly

## ASSEMBLY OF OPTIONAL ACCESSORIES

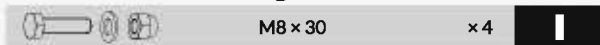
To assemble the optional plow blade (purchased separately) follow the below instructions.

### PLOW BLADE (OPTIONAL)

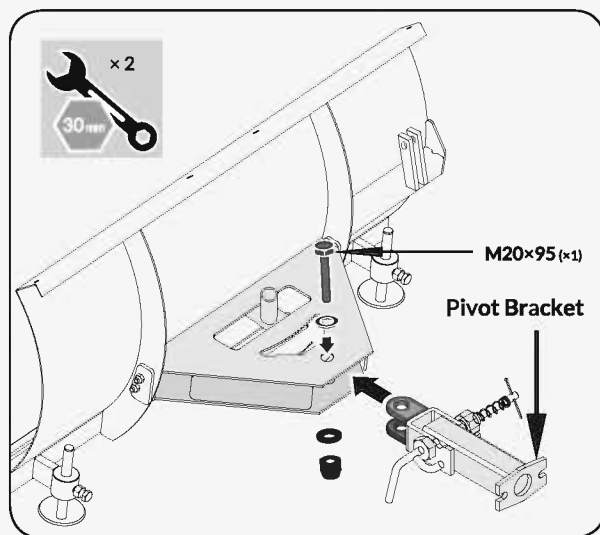
1. Mount the mounting bracket to the blade using M8×30 hex bolts, washers and nuts. (See **Figure 3a**)



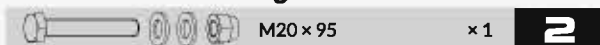
**Figure 3a**



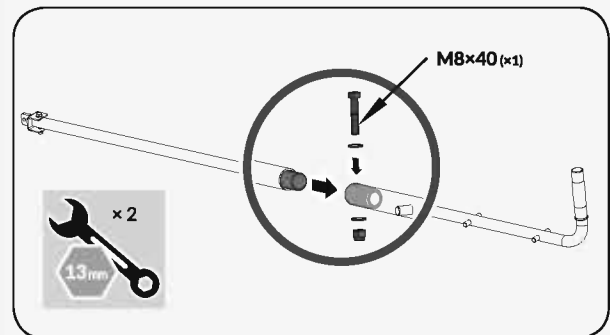
2. Position the pivot bracket inside the mounting bracket and align with mounting bracket holes. Secure with M20×95 hex bolt, washers and nut. (See **Figure 3b**)



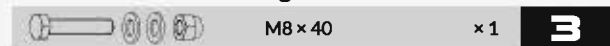
**Figure 3b**



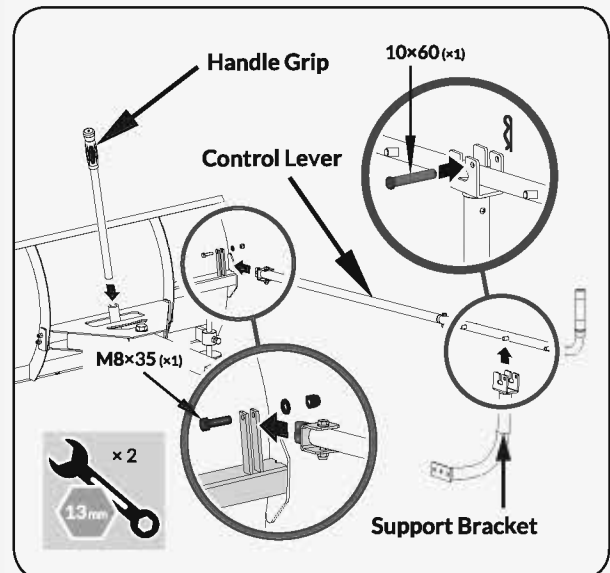
3. Insert the shorter control lever into the longer lever. Align holes and fasten with M8×40 hex bolt, washers and nut. (See **Figure 3c**)



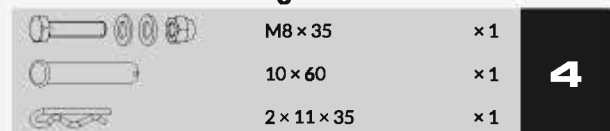
**Figure 3c**



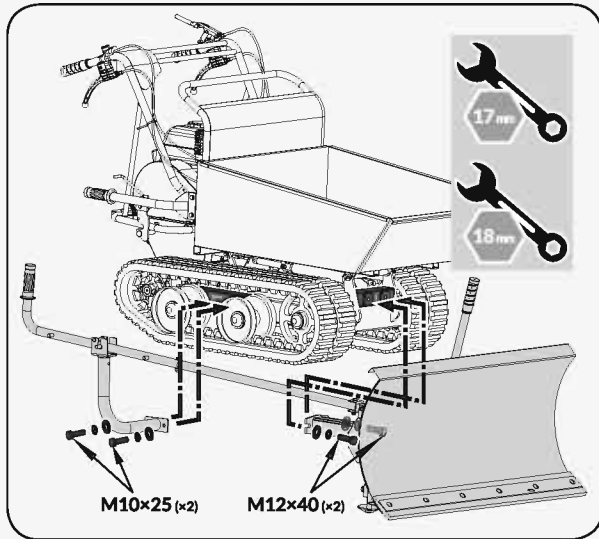
4. Attach control lever to the guide tube. Line up holes and fasten with M8×35 bolt, washers and nut.
5. Insert the handle grip into the holder.
6. Secure the support bracket into the control lever with pin 10×60 and bridge clip. (See **Figure 3d**)





**Figure 3d**



7. Install the already assembled plow blade to the trackbarrow as shown. (See **Figure 3e**)



**Figure 3e**

	M10 x 25	x 2	<b>5</b>
	M12 x 40	x 2	

# KNOW YOUR MACHINE

## FEATURES AND CONTROLS

Engine On/Off Switch

Throttle Control

Right Steering Lever

Clutch Control Lever

Left Steering Lever

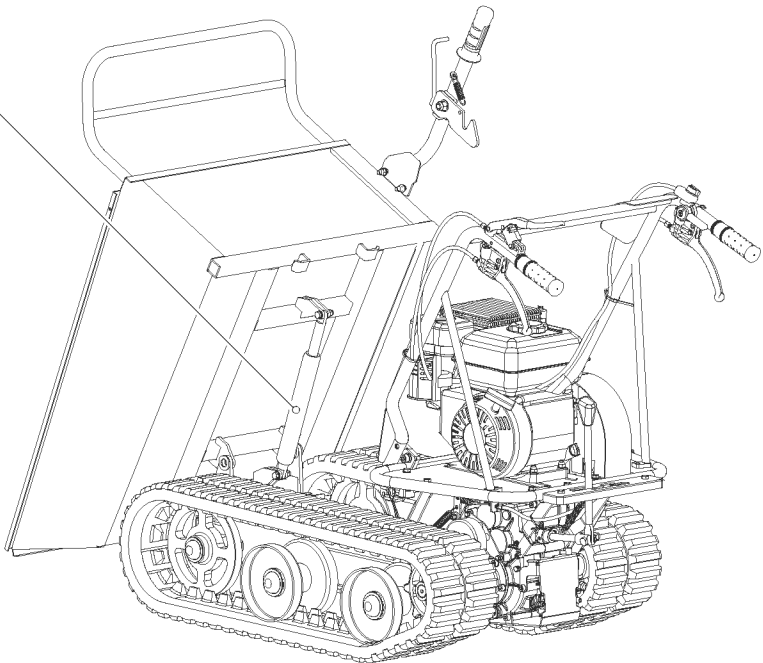
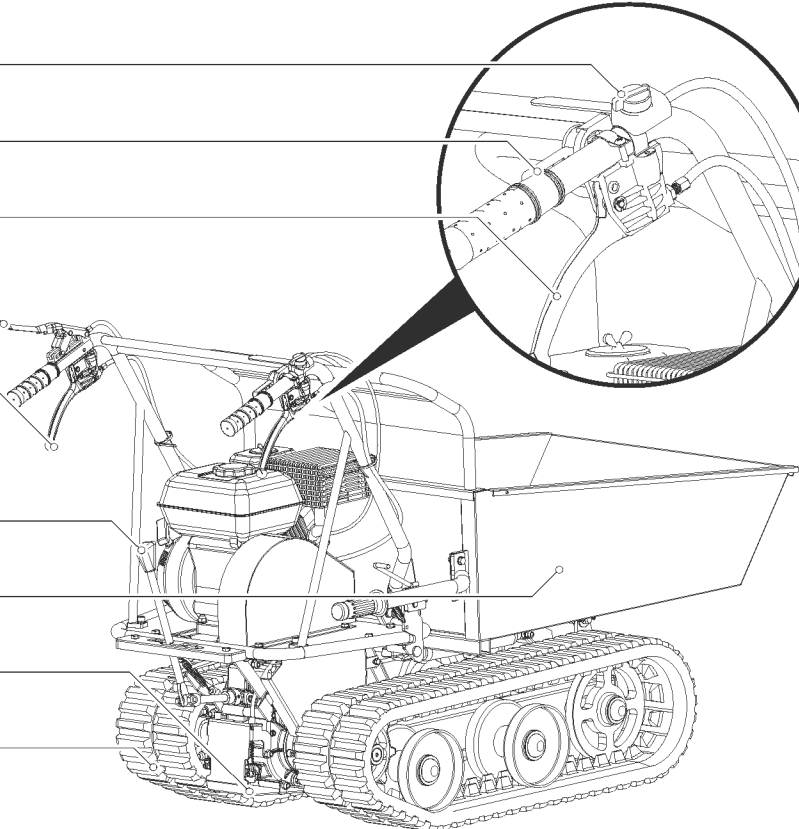
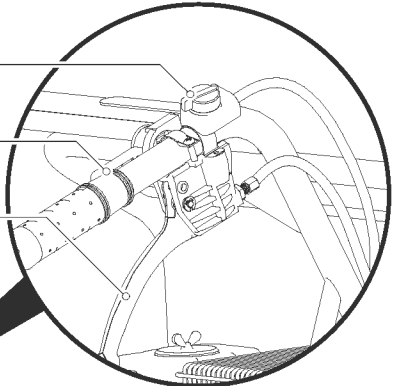
Gear Selection Lever

Hopper

Gearbox

Track

Gas Spring Assistance

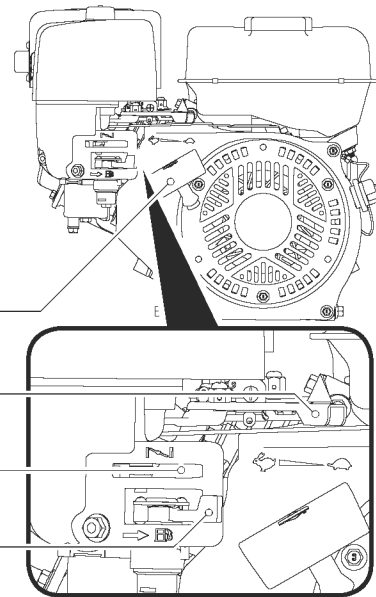


Recoil Starter Handle

Throttle Control

Choke Control

Fuel Shut-Off Valve



### GEAR SELECTION LEVER

- » The gear selection lever has 4 positions: 3 forward speeds and 1 reverse. To change speeds, move the speed shift lever to the desired position. The lever locks in a notch at each speed selection.



Always release the clutch control lever before changing speeds. Failure to do so will result in damage to the power trackbarrow.

- » Slower speeds are for heavier loads, while faster speeds are for transporting light loads or an empty hopper. It is recommended that you use a slower speed until you are familiar with the operation of the power trackbarrow.
- » If the engine slows down under a load or the tracks slip, shift the machine into a lower gear.
- » If the front of the machine rides up, shift the machine into a lower gear. If the front continues to ride up, lift up on the handles.

### LEFT/RIGHT STEERING LEVER

- » Operate the lever to turn left/right.



Operate the steering levers only at a reduced speed.

### GAS SPRING ASSISTANCE

- » The gas spring assistance provides support when lifting and lowering the hopper.

### ENGINE ON/OFF SWITCH

- » The engine switch has two positions. OFF - engine will not start or run. ON - engine will start and run.

### RECOIL STARTER HANDLE

- » The recoil starter handle is used to start the engine.

### FUEL SHUT-OFF VALVE

The fuel shut-off has two positions:

- » **CLOSED** (⊘) - Use this position to service, transport, or to store the unit.
- » **OPEN** (⊚) - Use this position to run the unit.

### THROTTLE CONTROL

- » The throttle control regulates the speed of the engine, and moves between **FAST** (👉), **SLOW** (👈), and **STOP** positions.
- » The throttle control will shut off the engine when it is moved to the STOP position.

### CHOKE CONTROL

- » The choke control is used to choke the carburetor and assist in starting the engine. The choke control slides between the **CHOKE CLOSED** (|) and **CHOKE OPEN** (↑) positions.



Never use choke to stop engine.

### CLUTCH CONTROL LEVER

- » Squeeze the control lever, clutch engaged. Release the lever, clutch disengaged.

# OPERATION

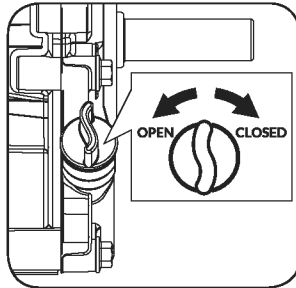
## ADD OIL TO ENGINE



No oil in the engine originally, but a bottle of engine oil is in scope of delivery. Don't start the engine before adding oil.

1. Make sure the power trackbarrow is on a flat, level surface.

2. Remove the oil fill cap/dipstick to add oil.



3. Using a funnel, add oil up to the **FULL** mark on the dipstick. (See engine manual for oil capacity, oil recommendation, and location of fill cap.)



**DO NOT OVERFILL.** Check engine oil level daily and add as needed.

## ADD GASOLINE TO ENGINE



Gasoline is highly flammable and explosive. You can be burned or seriously injured when handling fuel. Use extreme care when handling gasoline.



Fill the fuel tank outdoors, never indoors. Gasoline vapors can ignite if they collect inside an enclosure. Explosion can result.

1. The engine must be off and allowed to cool at least two minutes before adding fuel.
2. Remove the fuel filler cap and fill the tank. (See engine manual for fuel capacity, fuel recommendation, and location of fuel cap.)

### IMPORTANT: DO NOT OVERFILL!

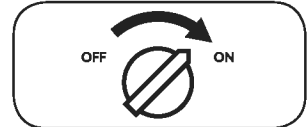


This equipment and/or its engine may include evaporative emissions control system components, required to meet EPA and/or CARB regulations, that will only function properly when the fuel tank has been filled to the recommended level. Overfilling may cause permanent damage to evaporative emissions control system components. Filling to the recommended level ensures a vapor gap required to allow for fuel expansion. Pay close attention while filling the fuel tank to ensure that the recommended fuel level inside the tank is not exceeded. Use a portable gasoline container with an appropriately sized dispensing spout when filling the tank. Do not use a funnel or other device that obstructs the view of the tank filling process.

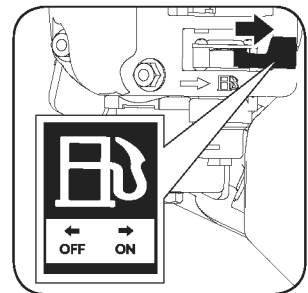
3. Reinstall the fuel cap and tighten. Always clean up spilled fuel.

## STARTING ENGINE

1. Move the engine switch to the ON position.

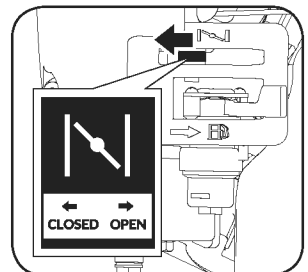


2. Open the fuel shut-off valve.

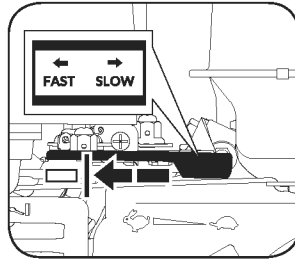


3. Move the choke lever to the CLOSED position.

» If the engine is hot, closing the choke is not necessary.



4. Move the throttle lever slightly to the FAST speed.



5. Pull the recoil starter until the engine starts. Return the recoil to the home position after each pull. Repeat the steps as needed. Once engine has started, set the throttle to the FAST position before you operate the unit.



*Rapid retraction of the starter cord (kickback) will pull your hand and arm toward the engine faster than you can let go. Broken bones, fractures, bruises, or sprains could result.*

## OPERATING

After the engine warms up, move the throttle lever to accelerate engine speed.

Engage the required gear and slowly squeeze the clutch control lever. If the gear does not engage immediately, slowly release the clutch lever and try again. In this way the power trackbarrow will start moving.

The power trackbarrow has the steering levers on the handlebars, which makes steering very easy. To turn right or left, simply pull the corresponding right or left steering lever.

The sensitivity of the steering increases in proportion to the speed of the machine and the load. With an empty machine, a light pressure on the lever is all that is needed to turn. When the machine is fully loaded, more pressure is required.

The power trackbarrow has a maximum capacity of 660 LBS. However, it is advisable to assess the load and adjust it according to the ground on which the machine will be used.

It is therefore advisable to cover such stretches using low gear and taking extra care. In such situations, the machine should be kept in low gear for the whole stretch.

Avoid sharp turns and frequent changes of direction while driving on rough, hard terrains full of sharp, uneven points with a high degree of friction.

Even though the unit has rubber tracks, remember to be careful when working in adverse weather conditions (ice, heavy rain and snow) or on types of ground that could make the power trackbarrow unstable.

Please note that as this is a tracked vehicle, it is subject to a considerable pitching movement when passing over bumps, holes and steps.

When the clutch control lever is released, the machine will stop and brake automatically.

If the machine is stopped on a steep slope, a wedge should be placed against one of the tracks.

## IDLE SPEED

Set the throttle control lever to the SLOW position to reduce stress on the engine when work is not being performed. Lowering the engine speed will help extend the life of the engine, as well as conserve fuel and reduce noise level.

## STOP ENGINE

To stop the engine in an emergency, simply turn the engine switch to the OFF position. Under normal conditions, use the following procedure:

1. Move the throttle lever to the SLOW (←) position.
2. Let the engine idle for one or two minutes.
3. Turn the engine switch to the OFF position.
4. Turn the fuel valve lever to the OFF (⊘) position.



*Sudden stopping at a high speed under a heavy load is not recommended. Engine damage may result.*



*Do not move the choke control to CLOSE to stop the engine. Backfire or engine damage may occur.*

## MAINTENANCE

Maintaining your YARDMAX power trackbarrow will ensure long life to the machine and its components.

### PREVENTIVE MAINTENANCE

1. Turn off the engine and disengage all command levers. The engine must be cool.
2. Keep the engine's throttle lever in its SLOW position and remove the spark plug wire from the spark plug and secure.
3. Inspect the general condition of the power trackbarrow. Check for loose screws, misalignment or binding of moving parts, cracked or broken parts, and any other condition that may affect its safe operation.
4. Use a soft brush, vacuum or compressed air to remove all contaminants from the machine. Then use high quality light oil to lubricate all moving parts.
5. Replace the spark plug wire.



Never use a "pressure washer" to clean your unit. Water can penetrate tight areas of the machine and its transmission case and cause damage to spindles, gears, bearings, or the engine. The use of pressure washers will result in shortened life and reduce serviceability.

### GEARBOX

The gearbox was filled with lubricant to the proper level at the factory. Unless there is evidence of leakage or service has been performed on the gearbox, no additional lubricant should be required. If lubricant is required, use GL-5 or GL-6, SAE85-95, EP gear oil lubricant. Do not use synthetic oil.

### GENERAL LUBRICATION

Lightly lubricate all moving parts of the machine at the end of the season or every 25 operating hours.

### ADJUSTING CLUTCH

- » When the clutch begins to show wear, the handle reach will become wider, making it more difficult to reach. Follow these steps to return the clutch lever back to its original position.

1. Loosen the jam nut by turning it counter clockwise with 10mm wrench. (see **Figure 4, Illustration 1**)
2. Tighten or loosen the cable by turning the cable adjustment nut clockwise or counter clockwise with 10mm wrench until you have reached your required tightness. (See **Figure 4, Illustration 2**)
3. Once tightness is set, return the jam nut against the handle to hold the cable in place. (See **Figure 4, Illustration 3**)

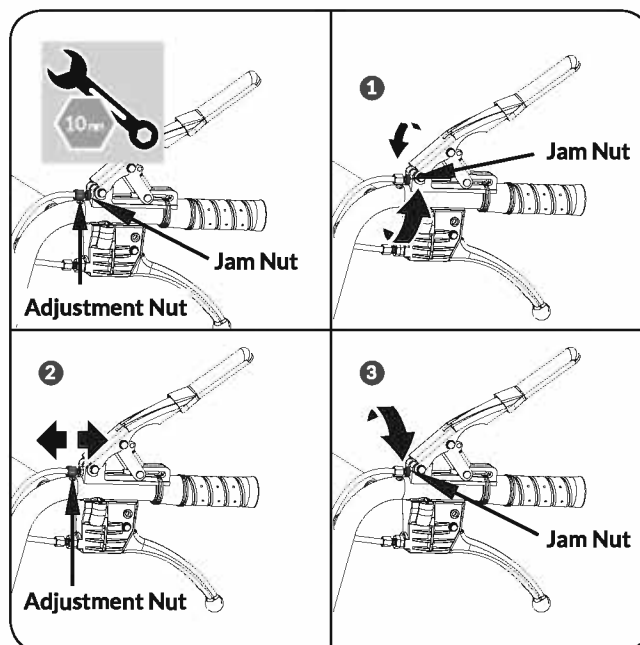


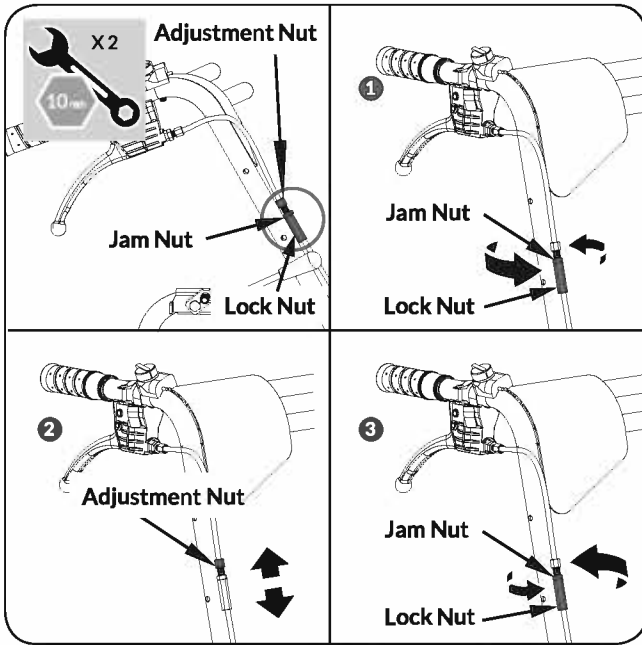
Figure 4

### ADJUSTING STEERING

- » If steering becomes difficult to engage follow these steps to adjust the cable tension.

1. Loosen the jam nut by turning it counter clockwise with 10mm wrench. (see **Figure 5a, Illustration 1**)
2. Tighten or loosen the cable by turning the cable adjustment nut clockwise or counter clockwise with 10mm wrench until you have reached your required tightness. (see **Figure 5a, Illustration 2**)
3. Once tightness is set, return the jam nut against the handle to hold the cable in place. (see **Figure 5a, Illustration 3**)

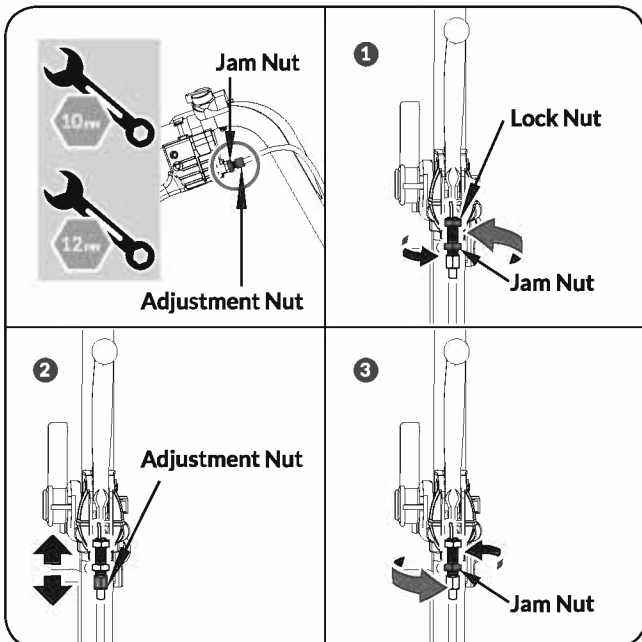




**Figure 5a**

» If the above adjustment does not create enough cable tension, follow the steps below:

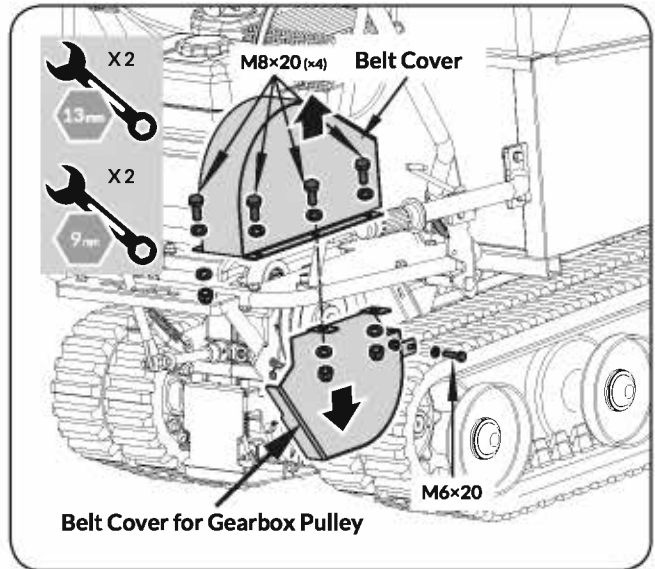
1. Loosen the jam nut by turning it counter clockwise with 12mm wrench. (see **Figure 5b, Illustration 1**)
2. Tighten or loosen the cable by turning the cable adjustment nut clockwise or counter clockwise with 10mm wrench until you have reached your required tightness. (see **Figure 5b, Illustration 2**)
3. Once tightness is set, return the jam nut against the handle to hold the cable in place. (see **Figure 5b, Illustration 3**)



**Figure 5b**

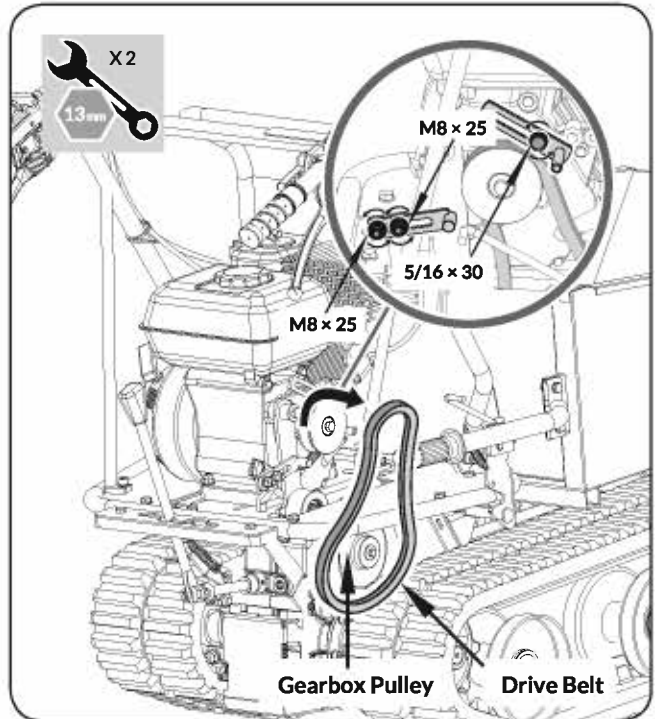
**REPLACING DRIVE BELT**

» Remove the belt covers as show. (See **Figure 6a**)



**Figure 6a**

» Loosen the two bolts M8x25 and one bolt 5/16x30 that fix the two belt blockers, no need to remove them. Pull out the belt. (See **Figure 6b**)



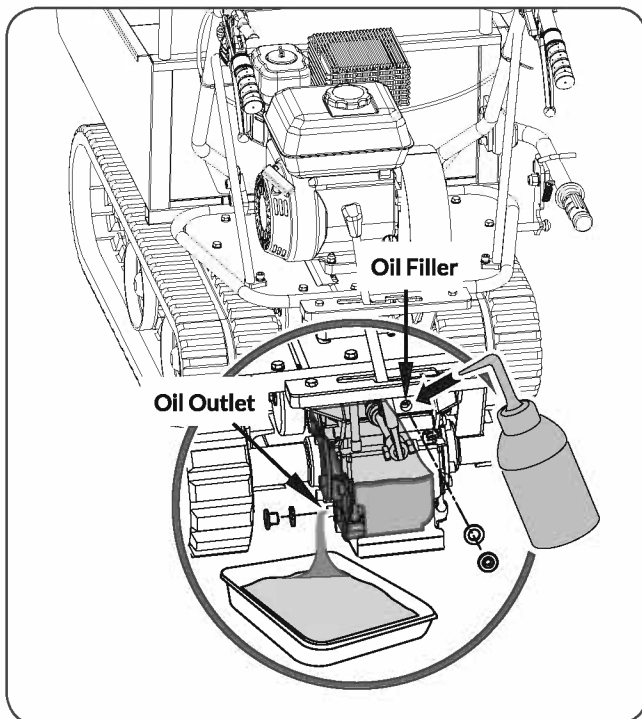
**Figure 6b**



You may need to loosen the belt guide bracket and slide back before removing belt.

## LUBRICATION

- » The gearbox is pre-lubricated and sealed at the factory. No need to lubricate until 50 hours use.
- » After first 50 hours use, change all the transmission oil. Capacity is 1.5L.
- » For future use, just check the oil level every 50 hours of working. If remove the drain plug, no oil flow out, then add the oil.
- » Use portable tool lithium #0 grease such as Lubriplate 6300AA, Lubriplate GR-132, or Multifak, e.g. EP-O.
- » Transmission oil must be replaced when engine is stopped and warm by unscrewing filler cap and drain plug. When oil is completely drained, replace filler cap and fill up with fresh oil. (See **Figure 7**)



**Figure 7**

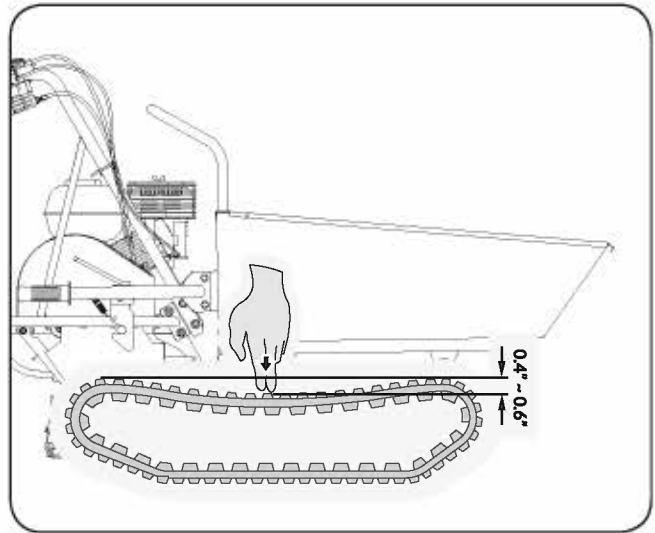
## TIGHTENING TRACKS

With use, tracks tend to loosen. When operating with loose tracks, they tend to slip over the driving wheel causing it to jump its housing, thus damaging wear to the housing.

To check track tightness, proceed as follows.

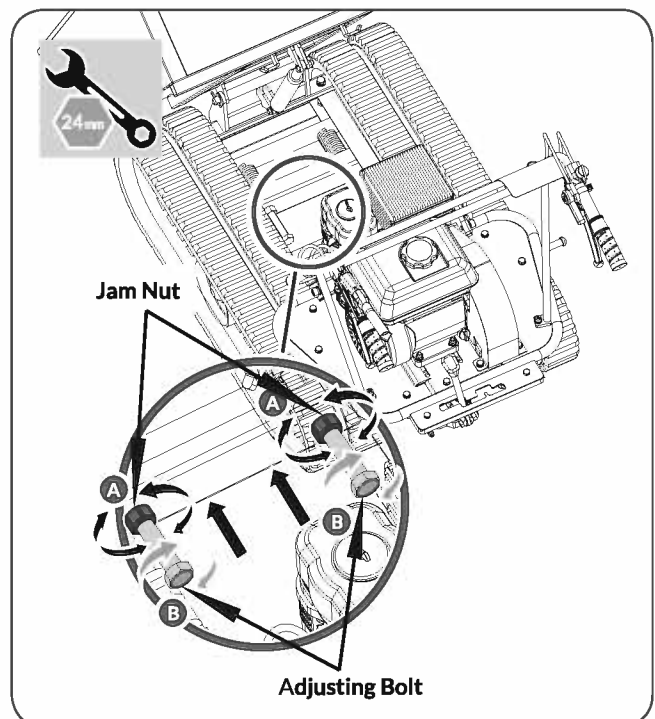
1. Set the machine on a flat surface with compact ground, or on asphalt or pavement.
2. Lift the machine and set it on blocks or supports rated for the weight of the machine so that the tracks are approximately 4" off the ground.

3. Measure the track midline vs. the horizontal line. The reading must not be more than 0,4"~0,6".



If the distance is greater, proceed as follows.

1. Use the tipping handle to tip the hopper and set it on blocks or supports rated for the weight of the box.
2. Loosen locknut A.
3. Tighten bolt B until the correct tightness is restored.
4. Secure bolt B by tightening locknut A thoroughly.
5. Return the hopper to its original position.



**Figure 8a**

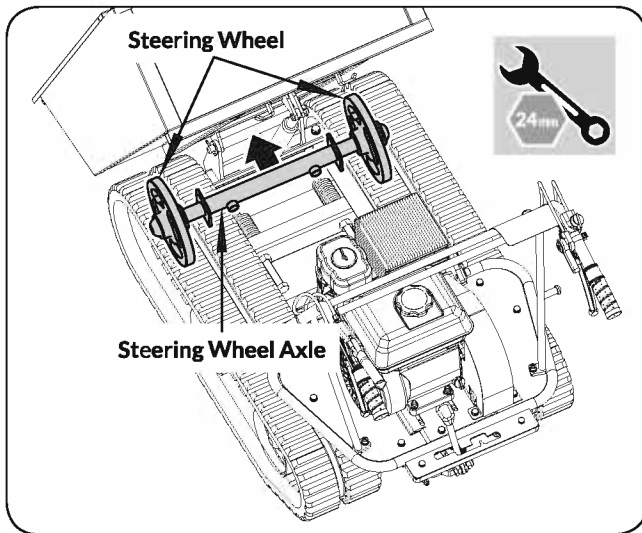


Figure 8b



Do not over-tighten your track. The adjustment of the track and the brakes are linked. The braking power will lessen the more the track is tightened.



If the adjustment bolt has no more adjustment left, the tracks may have to be replaced.

## REPLACING TRACKS

Check the condition of the tracks periodically. If any track is cracked or frayed, it should be replaced as soon as convenient.

1. Lift up the hopper and insert a support rod for safety purposes.
2. Lift the machine and set it on blocks or supports rated for the weight of the machine so that the tracks are approximately 4" off the ground. (See Figure 9a)

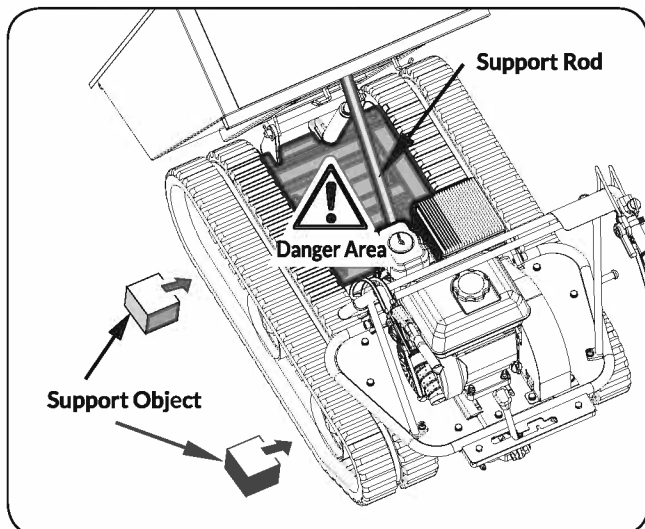


Figure 9a

3. Loosen the adjusting bolts and pull the steering wheel axle toward the engine, then track will be loosen. (See Figure 9b)

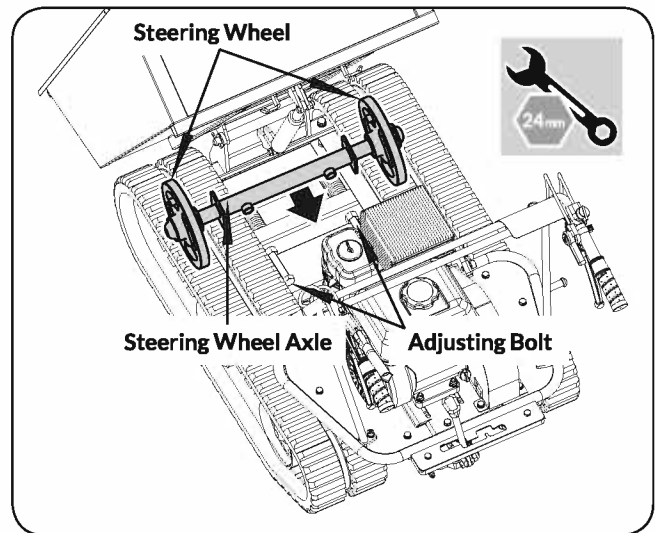


Figure 9b

4. Pull out the whole track. (See Figure 9c)

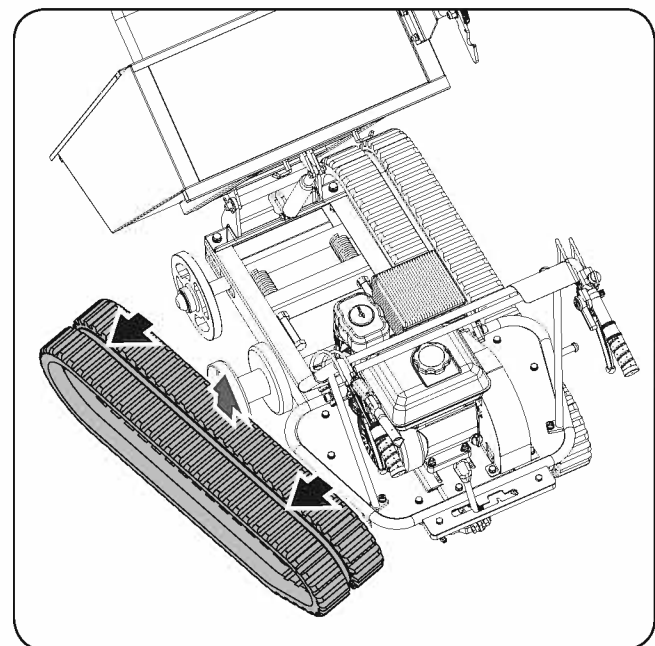


Figure 9c



When removing or installing the tracks, be careful not to get your fingers caught between the track and pulley.

## ENGINE MAINTENANCE

- » Refer to the Engine Manual included in your unit for the information on engine maintenance. Your engine manual provides detailed information and a maintenance schedule for performing the tasks.

---

## STORAGE

---

If the power trackbarrow will not be used for a period longer than 30 days, follow the steps below to prepare your unit for storage.

1. Drain the fuel tank completely. Stored fuel containing ethanol or MTBE can start to go stale in 30 days. Stale fuel has high gum content and can clog the carburetor and restrict fuel flow.
2. Start the engine and run until it stops. This helps prevent gum deposits from forming inside the carburetor and possible engine damage.
3. While the engine is still warm, drain the oil from the engine. Refill with fresh oil of the grade recommended in the Engine Manual.
4. Use clean cloths to clean off the outside of the machine and to keep the air vents free of obstructions.



*Do not use strong detergents or petroleum based cleaners when cleaning plastic parts. Chemicals can damage plastics.*

5. Inspect for any loose or damaged parts. Repair or replace damaged parts and tighten loose screws, nuts or bolts.
6. Store your unit on flat ground in a clean, dry building that has good ventilation.

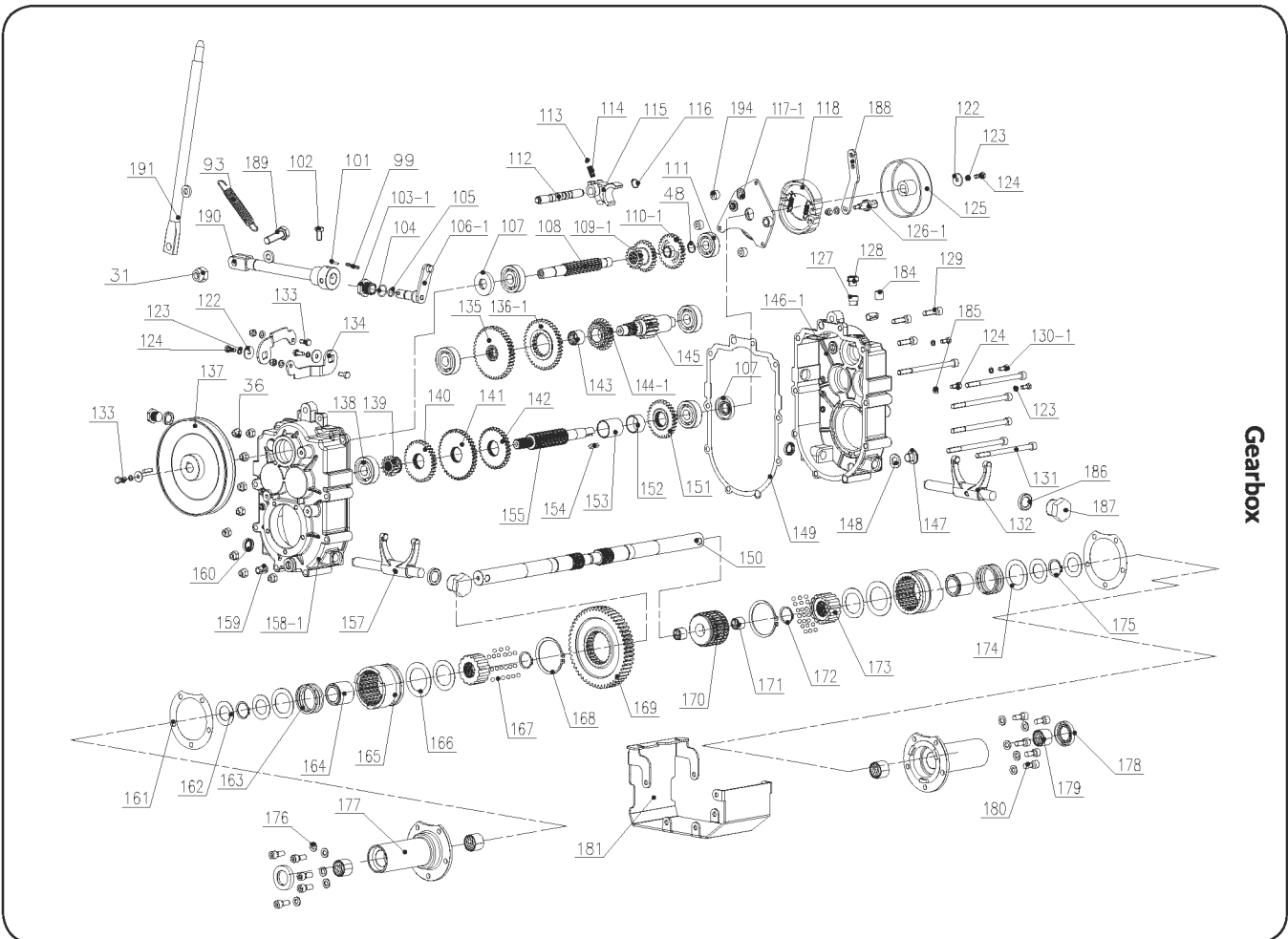


*Do not store the machine with fuel in a non-ventilated area where fuel fumes may reach flame, sparks, pilot lights or any ignition sources.*

## TROUBLESHOOTING

Problem	Cause	Remedy
Engine fails to start	<ol style="list-style-type: none"> <li>1. Spark plug wire is disconnected</li> <li>2. Out of fuel or stale fuel</li> <li>3. Engine and/or Fuel valve is not in ON position</li> <li>4. Choke lever is not in CLOSE position</li> <li>5. Blocked fuel line</li> <li>6. Fouled spark plug</li> <li>7. Engine flooding</li> <li>8. Belt tension lever is engaged</li> </ol>	<ol style="list-style-type: none"> <li>1. Attach spark plug wire securely to spark plug</li> <li>2. Fill with clean, fresh gasoline</li> <li>3. Engine and Fuel valve must be in ON position</li> <li>4. Choke level must be in CLOSE position for a cold start</li> <li>5. Clean fuel line</li> <li>6. Clean, adjust gap, or replace</li> <li>7. Wait a few minutes to restart, but do not prime</li> <li>8. Disengage the belt tension lever</li> </ol>
Engine runs erratically	<ol style="list-style-type: none"> <li>1. Spark plug wire is loose</li> <li>2. Unit running with Choke lever in CLOSE position</li> <li>3. Blocked fuel line or stale fuel</li> <li>4. Vent plugged</li> <li>5. Water or dirt in fuel system</li> <li>6. Dirty air cleaner</li> <li>7. Improper carburetor adjustment</li> </ol>	<ol style="list-style-type: none"> <li>1. Connect and tighten spark plug wire</li> <li>2. Move choke lever to OPEN position</li> <li>3. Clean fuel line. Fill tank with clean, fresh gasoline</li> <li>4. Clear vent</li> <li>5. Drain fuel tank. Refill with fresh fuel</li> <li>6. Clean or replace air cleaner</li> <li>7. Refer to engine manual</li> </ol>
Engine overheats	<ol style="list-style-type: none"> <li>1. Engine oil level low</li> <li>2. Dirty air cleaner</li> <li>3. Air flow restricted</li> <li>4. Carburetor not adjusted properly</li> </ol>	<ol style="list-style-type: none"> <li>1. Fill crankcase with proper oil</li> <li>2. Clean air cleaner</li> <li>3. Remove housing and clean</li> <li>4. Refer to engine manual</li> </ol>
One of the two tracks is blocked	Foreign bodies have worked their way between the track and the frame	Remove the foreign body
Machine does not move while engine is running	<ol style="list-style-type: none"> <li>1. Gear is not properly selected</li> <li>2. Driving tracks not tight enough</li> </ol>	<ol style="list-style-type: none"> <li>1. Ensure gear lever is not in-between two different gears</li> <li>2. Tighten driving tracks</li> </ol>





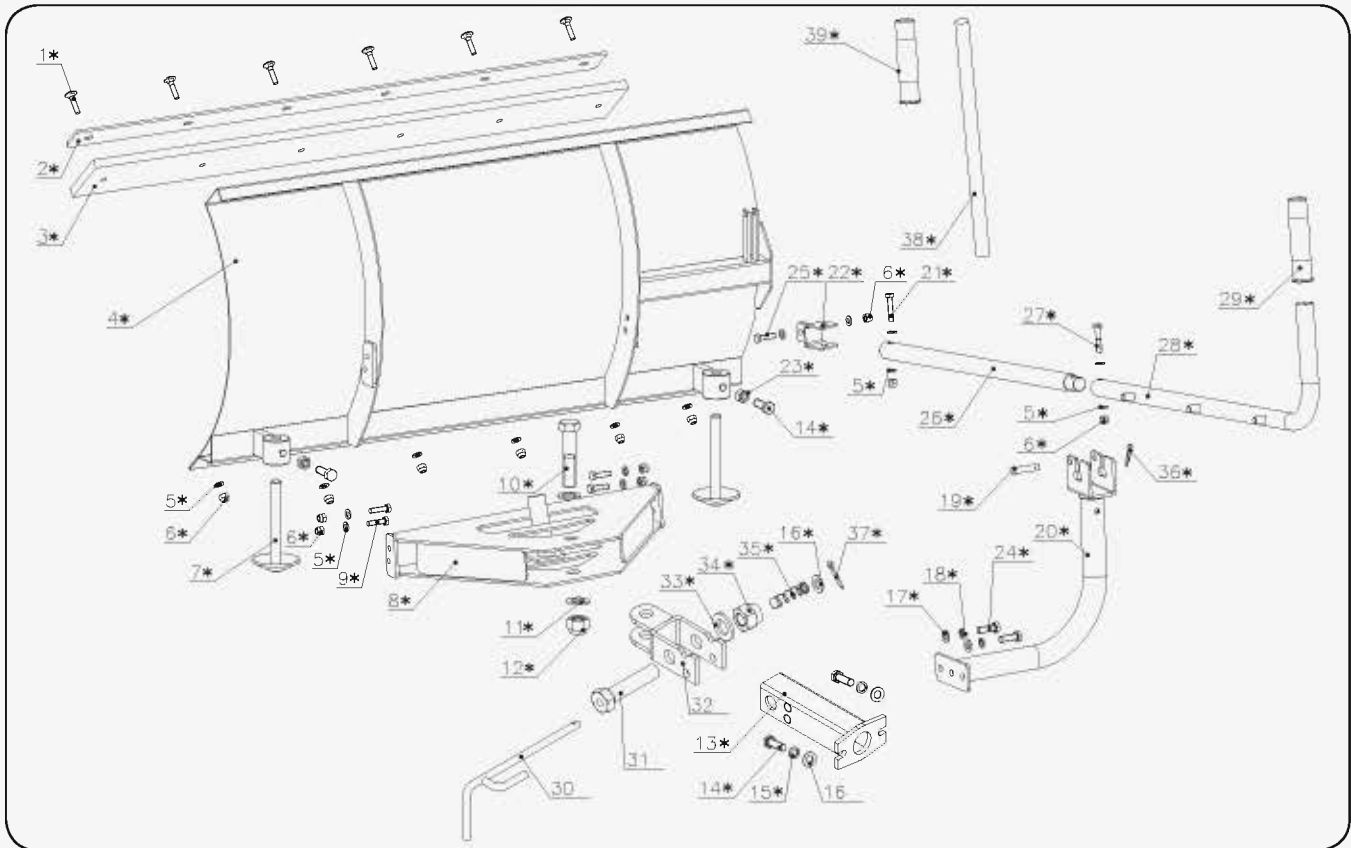
## PARTS LIST

No.	Description	Qty	No.	Description	Qty	No.	Description	Qty
1	Tensioner Pulley Cable	1	37-1	Tensioner Pulley Bracket	1	73	Track 180×60	2
2	Safety Control Handle	1	38	Engine	1	74-1	Axle Head Cover(42)	2
3	Screw M6×16	1	39	Key 4.7×33	1	75	Circlip 42	8
4	Screw M5×20	2	40	Belt Protect Frame	1	76	Bear 61905-2RS	4
5	Nut M5	2	41	Bolt 5/16-24×30	2	77-1	Guiding Wheel	2
6	Handle Sleeve	2	42-1	Fixed Bracket	1	78	Sealing Ring30×42×7	2
7	Throttle Cable	1	43	Washer 8	2	79	Nut M16	2
8	Throttle Lever	1	44	Bolt M10×60	2	80	Bolt M16×110	2
9	HOOP	1	45-1	Belt Pulley	1	81-1	Underframe Weldment	1
10	ON/OFF Switch	1	46	Screw M5×12	1	82-1	Guide Wheel Axle	1
11-1	Handle Frame Assembly	1	47	Tensioner Pulley	1	83	Bolt M10×20	4
12	Lower Handle	2	48	Circlip 15	2	84-1	Support Bracket	1
13	Washer ø6	10	49	Bearing 6202-2Z	2	85-1	Flat Gasket 16	2
14	Screw M6×35	1	50-1	Gear Box	1	86-1	Plain Shaft	1
15	Screw M6×60	1	51	Circlip 35	1	87	Pin $\phi$ 4×35	2
16	Right/Left Steering Lever Cable	2	52	Large Belt Pulley Cover	1	88-1	Dumper Box	1
17	Screw M10×20	8	53	Nut M6	8	89	Operation Lever Frame	1
18	Washer10	26	54	Bolt M6×20	1	90	Handle Frame Weldment	1
19	Washer10	22	55	Wheel Axle Press Board	2	91	Nut M12	1
20	Bolt M8X16	6	56	Support Plate (right)	1	92	Washer 12	2
21	Washer 8	39	57	Belt Blocker	1	93	Extension Spring	1
22-1	Soleplate (left)	1	58-1	Connecting Angle Block	1	94	Handle Sleeve	1
23	Bolt M8×25	11	59-1	Screw M6×20	2	95	Guiding Spring	2
24	Washer 8	7	60-1	Bolt M8×45	4	96	Locating sleeve	2
25-1	Handle Mounting Frame	1	61	Bolt M10×65 w/glue	8	97-1	Gas Spring	1
26	Bolt M8×20	3	62	Nut M8	2	98	Bolt 5/16-24×20	1
27	Soleplate (right)	1	63-1	Cable Fixing Base	1	99	Pin 5x30	1
28	Belt B32	1	64	Rubber Mat	4	100	Discontinued	N/A
29	Pulley Cover Weldment	1	65-1	Support Plate (left)	1	101	Pin 3×30	1
30	Lever Knob	1	66	Long Extension Spring	1	102-1	Bolt M8×12 w/glue	1
31	Lock Nut M10	12	67	Skeleton Oil Seal	4	103-1	Orientation Nut	1
32	Bolt M8×30	2	68	Weight Supporting Wheel Weldment	4	104	Washer Groupware D20	1
33	Bolt M10×70	1	69	Bearing 6204-2RS	8	105	O-Ring 11.2×1.8	1
34	Brake Cable	1	70	Washer 10	6	106-1	Lever Mount Bracket	1
35	Driving Wheel	2	71	Bolt M10×25	6	107	Seal FB17×40×7	2
36	Nut M8	25	72-1	Axle Head Cover(47)	4	108	Spline Shaft I	1
						109-1	Duplex Slip Gear	1



No.	Description	Qty	No.	Description	Qty	No.	Description	Qty
110-1	Gear	1	139	Gear II-5	1	168	Circlip 58	2
111	Bearing 6302	1	140	Gear II-4	1	169	Output Gear	1
112	Gearshift Fork Guide Pin	1	141	Gear II-3	1	170	Intermediate Joint Bush	1
113	Spring	1	142	Gear II-2	1	171	Intermediate Joint Bush Composite Bushing	2
114	Steel Ball 6	1	143	Gear III-2 Bush	1	172	Circlip 26	2
115	Gearshift Fork	1	144-1	Gear III-2	1	173	Joint Bush	2
116	Circlip 12	1	145	Gear Shaft III	1	174	Spring Gasket	4
117-1	Rivet Assembly	1	146-1	Gear Box Case ( L )	1	175	Circlip 25	2
118	Brake Disk	1	147	Plug M14×1.5	2	176	Washer 8	10
119	Discontinued	N/A	148	Washer Groupware 14	2	177	Output Shaft Bushing	2
120	Discontinued	N/A	149	Gear Box Case	1	178	Seal FB42×25×7	2
121	Discontinued	N/A	150	Output Shaft	2	179	Output Shaft Composite Bushing	4
122	Washer6	4	151	Gear II-1	1	180	Screw M8×25 w/glue	12
123	Washer6	7	152	Bush 2	1	181	Guard Cover	1
124	Bolt M6×16	4	153	Bush 1	1	182	Bolt M8×35	2
125	Expansion Brake Cover	1	154	Key C5×20	2	183	Plug 35×35	2
126-1	Stud	1	155	Spline ShaftII	1	184	Sponge Gasket	1
127	Discontinued	N/A	156	Discontinued	N/A	185	Seal Gasket	1
128	Vent-Plug	1	157	Clutch Fork Shaft (R)	1	186	Seal Gasket 6	2
129	Screw M8×30	3	158-1	Gear Box Case ( R )	1	187	Screw-Plug M18×1.5	2
130-1	Expansion Brake Lock Bolt	3	159	Pin 12×20	2	188	Brake Pull Plate	1
131	Screw M8×130	6	160	Seal FB16×22×4	2	189	Bolt M10×35	1
132	Clutch Fork Shaft (L)	1	161	Output Shaft Bush Gasket	2	190	Shifting Lever I	1
133	Bolt M6×20	3	162	Gasket 1	4	191	Shifting Lever II	1
134	Swing Plate	2	163	Clutch Spring	2	192	Gear Shifting Board	1
135	Gear III-4	1	164	Spring Guide Bush	2	193	Small Pulley Pressure Pad	1
136-1	Gear III-3	1	165	Clutch Sleeve	2	194	Bushing	3
137	Large Belt Pulley	1	166	Spring Gasket	2	195	Shock Pad	4
138	Bearing 6303	5	167	Steel Ball 5	70			

### Plow Blade (Optional)



### OPTIONAL PLOW BLADE

No.	Description	Qty
1*	Bolt M8×35	6
2*	Shave Plate	1
3*	Rubber Plate	1
4*	Blade Weldment	1
5*	Washer8	16
6*	Nut M8	13
7*	Landing Leg Weldment	2
8*	Blade Fixed Bracket Weldment	1
9*	Bolt M8×30	4
10*	Bolt M20×95	1
11*	Washer20	2
12*	Nut M20	1
13*	Blade Connecting Bracket Weldment	1

No.	Description	Qty
14*	Bolt M12×40	4
15*	Washer12	2
16*	Washer12	3
17*	Washer10	2
18*	Washer10	2
19*	Pin 10×60	1
20*	Curved Support Bracket Weldment	1
21*	Bolt M8×50	1
22*	Active Connecting Weldment	1
23*	Nut M12	2
24*	Bolt M10×25	2
25*	Bolt M8×35	1
26*	Adjusting Rod Weldment B	1

No.	Description	Qty
27*	Bolt M8×40	1
28*	Adjusting Rod Weldment A	1
29*	Handle Sleeve 28	2
30*	Limiter Rod Wedment	1
31*	Bolt M24×110	1
32*	Limiter Weldment	1
33*	Washer24	1
34*	Lock Nut M24	1
35*	Spring	1
36*	Bridge Pin 2×11×35	1
37*	Pin 4×40	1
38*	Handle Grip 2	1
39*	Handle Sleeve 25	1



*Tame the Great Outdoors®*

