



Electric Log Splitter

Operator's Manual

MODEL NUMBER
YS0552

SERIAL NUMBER

PURCHASE DATE

Both model number and serial number may be found on the main label. You should record both of them in a safe place for future use.

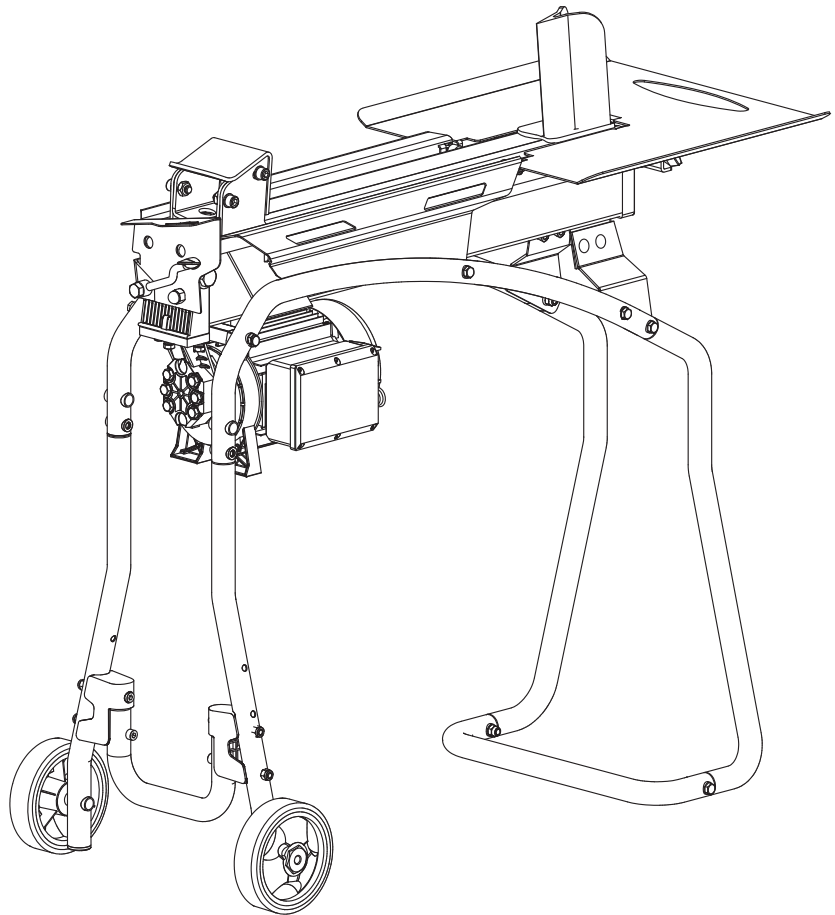

FOR YOUR SAFETY

READ AND UNDERSTAND THE ENTIRE MANUAL BEFORE OPERATING MACHINE

Your new YARDMAX™ electric log splitter offers quality construction, and is easy and safe to operate. With proper use and care, it is designed to give you many years of dependable service.

Prepare to experience the durability to take on any job – with the ease, portability, and convenience of clean, electric splitting!

Discover the YARDMAX Advantage

At YARDMAX, we understand that land ownership definitely has its privileges, but it also comes with a great deal of responsibility. When duty calls and you need to respond, will you have what it takes to tame the great outdoors?

When looking for outdoor power equipment (OPE) to get the job done right, at the right price, YARDMAX delivers the perfect combination of performance and practicality. YARDMAX has a solution that's right for you.

MAX Performance, MAX Value, MAX Support – that's YARDMAX

- ✓ Backed by decades of proven manufacturing expertise
- ✓ Enhanced design features come standard
- ✓ Engineered for the best user experience
- ✓ Quality metal parts are used instead of plastic
- ✓ A robust warranty supports all products
- ✓ Budget-friendly prices make it practical



Up for the job? YARDMAX is.

TABLE OF CONTENTS

Introduction	1
Specifications	3
Symbols	3
Safety	4
Contents Supplied	5
Assembly	6
Know Your Machine	8
Operation	9

Freeing a Jammed Log	11
Replacing Hydraulic Oil	12
Sharpening the Wedge	13
Troubleshooting	14
Wiring Diagram	14
Plumbing Diagram	14
Parts Diagram	15
Parts List	16



Carefully read through this entire operator's manual before using your new Log Splitter. Pay attention to all cautions and warnings.

ENVIRONMENTAL



Recycle unwanted materials instead of disposing of them as waste. All tools, hoses, and packaging should be resorted, taken to the local recycling center and disposed of in an environmentally safe way.

MODEL AND SERIAL NUMBERS

Record the model and serial number as well as date and place of purchase for future reference. Have this information available when ordering parts or optional accessories and when making technical or warranty inquiries.

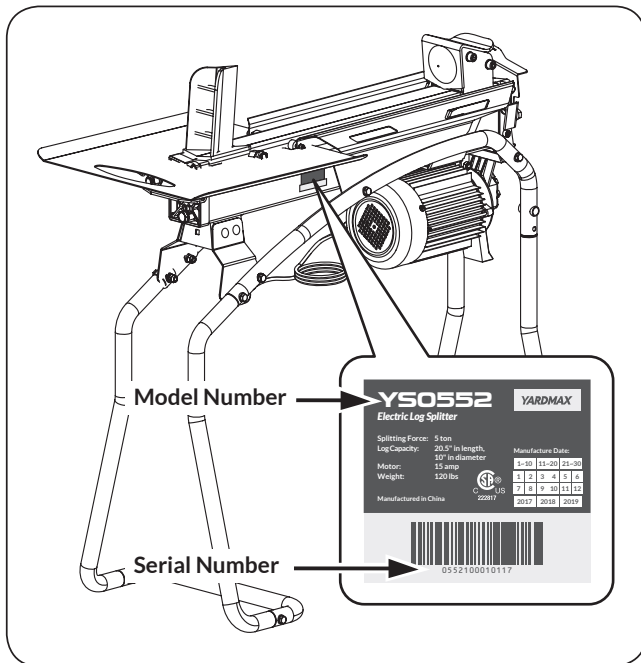

DISCLAIMER

YARDMAX reserves the right to discontinue, change, and improve its products at any time without notice or obligation to the purchaser. The descriptions and specifications contained in this manual were in effect at printing. Equipment described within this manual may be optional. Some illustrations may not be applicable to your unit.

SUPPORT

Have questions about your YARDMAX equipment? Call us at 844-YARDMAX, email us at support@yardmax.com, or contact us via your favorite social media site.

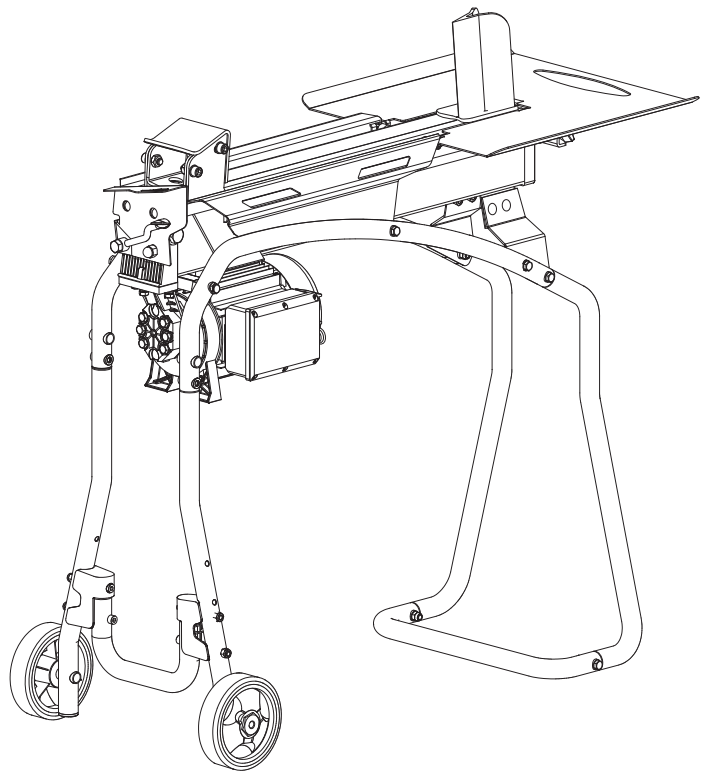

SPECIFICATIONS

Model Number	YS0552
Splitting Force	5 ton
Log Capacity	20.5" in length and 10" in diameter
Wedge Size	5"
Hydraulic Capacity	0.93 gal
Cylinder Cycle Time	16 sec
Wheel size	6"
Motor	15 amp
Product Weight	120 lbs
Size – without Stand	40.5" x 13.8" x 19.3"
Size – with Stand	40.5" x 17.7" x 39"
Operating Position	Horizontal
Stroke Limiter	Included
Stand	Included
Log Tray	Included

SYMBOLS

The rating plate on your machine may show symbols. These represent important information about the product or instructions on its use.



Read these instructions carefully.



Wear eye protection.



Wear protective gloves.



Wear safety footwear.



Do not remove or tamper with the protection and safety devices.



Properly dispose of waste oil!



Keep hands and fingers away from all pinch points.



Never remove partially split wood from the wedge with your hands. Fingers may become trapped between the split wood.



Warning! Stay clear of moving parts!



Disconnect the main plug prior to the repair, cleaning, and maintenance of the splitter!



Keep children and bystanders off and away.

SAFETY

KNOW YOUR LOG SPLITTER

Read this manual and all labels to understand your YARDMAX log splitter and its limitations and potential hazards.

DRUGS, ALCOHOL, AND MEDICATION

Do not operate your log splitter while under the influence of drugs, alcohol, or any medication that could affect your ability to use it properly.

AVOID DANGEROUS CONDITIONS

Secure your log splitter on level ground. Keep your work area clean and well lighted. Cluttered areas may cause injuries. Do not use your log splitter in wet or damp areas or expose it to rain. Do not use it in areas where fumes from paint, solvents, or flammable liquids pose a potential hazard.

INSPECT YOUR LOG SPLITTER

Inspect your log splitter before turning it on. Keep guards in place and in working order. Regularly check to see that keys and adjusting wrenches are removed from the tool area before turning it on. Replace damaged, missing, or failed parts before using it.

DRESS PROPERLY

Do not wear loose clothing, gloves, or jewelry (rings, watches) that can be caught in moving parts. Wear protective nonconductive gloves and nonskid footwear. Pull long hair back or wear a hat to prevent hair from getting caught in the machine.

PROTECT YOUR EYES

Always wear safety glasses. Log splitters can throw foreign objects into the eyes, causing permanent eye damage. Everyday glasses do not have impact-resistant lenses and should not replace safety glasses. Z87 rated glasses are recommended.

PROTECT YOUR BODY

Always stand behind the log splitter and be alert. Logs can become a projectile under force of the ram in any direction.

KEEP VISITORS AND CHILDREN AWAY

Only one person at a time should operate the log splitter. Bystanders should keep a safe distance from the work area, standing behind the operator. Never have another person help you free a jammed log.

EXTENSION CORDS

Improper use of extension cords can result in overheating. Your extension cord should be no longer than 30 feet and a minimum of 12 gauge with a 3-prong grounded plug.

AVOID ELECTRICAL SHOCK

Never open the pushbutton box on the motor. For any service please contact YARDMAX or an authorized service center. Make sure your fingers do not touch the plug's metal prongs when plugging or unplugging the log splitter.



WARNING! Stay of clear of all moving parts!

INSPECT YOUR LOG

Make sure there are no nails or foreign objects in logs to be split. The ends of the logs must be cut square. Branches must be cut off flush with the trunk. Knots can make a log split differently and could cause the log to become a projectile.

DON'T OVERREACH

Do not operate your log splitter on a slippery surface. Never stand on the log splitter.

AVOID INJURY FROM ACCIDENTS

Always pay attention to the movement of the log ram. Do not load the log until the log ram has stopped.

PROTECT YOUR HANDS

Keep your hands out of the way of all moving parts. Keep your hands away from splits and cracks that open in the log; they may close suddenly and crush or cut off your hands. Do not remove jammed logs with your hands.

DO NOT FORCE TOOL

Your log splitter will do a better and safer job at its design rate. Never try to split logs larger than those indicated in the specifications table. This could be dangerous and may damage the machine. Do not use your log splitter for anything other than splitting logs.

NEVER LEAVE TOOL UNATTENDED

Do not leave your log splitter until it has come to a complete stop.

DISCONNECT POWER

Unplug your log splitter when not in use and before making adjustments, changing parts, cleaning, or servicing. Consult the technical manual before servicing.

PROTECT THE ENVIRONMENT

Take used oil to an authorized collection point. Do not pour into drains, soil, or water.

MAINTAIN YOUR LOG SPLITTER WITH CARE

Keep your log splitter and its parts clean.

CHILDPROOF YOUR WORKSHOP

Store your log splitter away from children and others not qualified to use it.

CONTENTS SUPPLIED

Your YARDMAX log splitter comes partially assembled and contains the following:

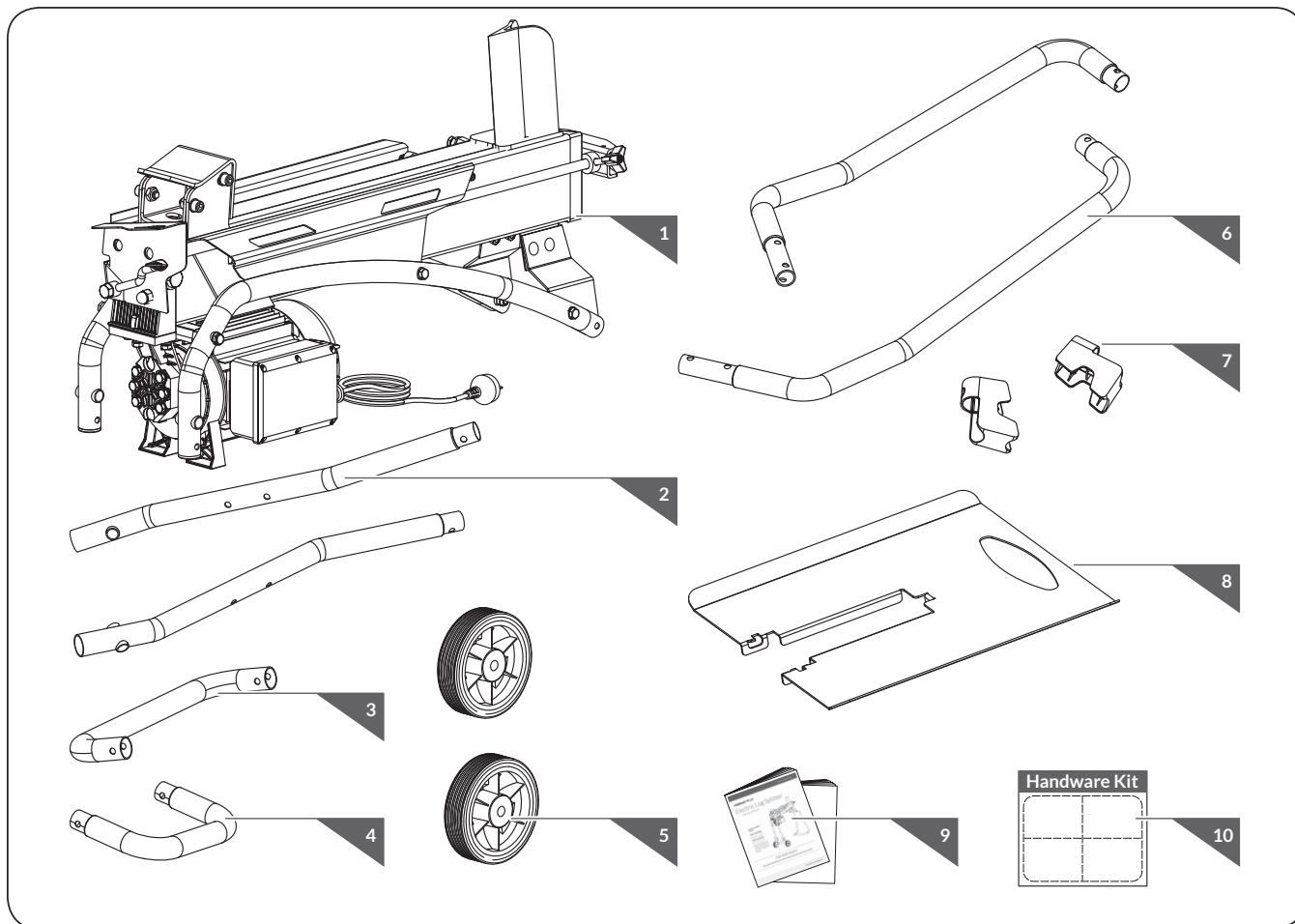

1. Log Splitter Frame
2. Rear Support Legs (1 Pair)
3. Front U-Shaped Connecting Pipe
4. Rear U-Shaped Connecting Pipe
5. Wheel (1 Pair)
6. Front Support Legs (1 Pair)
7. Support Brackets (1 Pair)
8. Log Tray Table
9. Operator's Manual

10. Hardware Kit

	M8 X 85	X 2	1
	M8 X 100	X 2	
		X 2	2
		X 2	
	M8 X 45	X 2	3
	M8 X 45	X 2	4
	M8 X 45	X 2	

TOUCH-UP PAINT

	Orange	X 1	5
	Light Gray	X 1	

ASSEMBLY

RECOMMENDED TOOLS

To assemble your YARDMAX log splitter, you will need a 6mm hex hand socket or allen wrench, 13mm wrench, and pliers.

1. Line up the holes in the rear support legs with the holes in the gray support brackets and rear U-shaped connecting pipe. From the inside, insert the M8X85 bolts through the top holes and the M8X100 bolts through the bottom holes, then secure with arc washers and nuts. (See **Figure 1**)

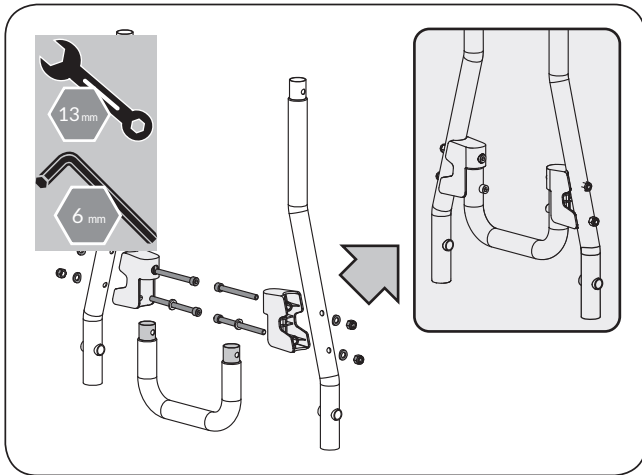

Figure 1

	M8 X 85	X 2	1
	M8 X 100	X 2	

3. Insert the bottom ends of the front support legs into the front U-shaped connecting pipe and line up the holes. Insert M8X45 bolts each with an arc washer through the outside holes, then secure with arc washers and nuts. (See **Figure 3**)

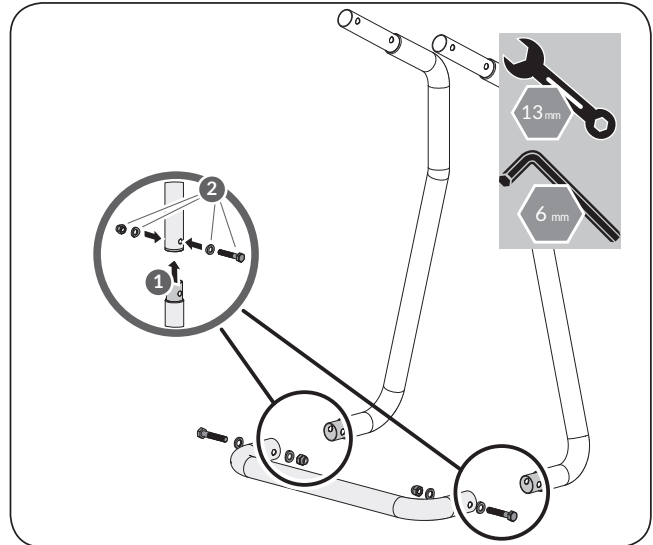

Figure 3

	M8 X 45	X 2	3
--	---------	-----	----------

2. Insert the axles through the wheels and attach the wheel covers. Insert the wheels and axles into the holes at the base of the rear leg assembly. Use pliers to attach the C-clip over the end of the axle. (See **Figure 2**)

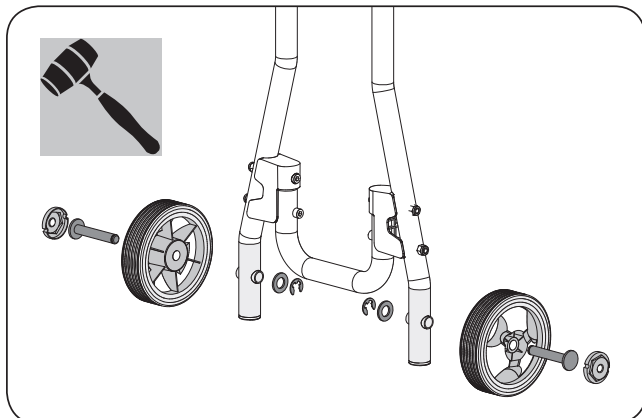

Figure 2

		X 2	2
		X 2	

4. Remove the two M8X45 bolts that securing support frame tubes and mounting brackets. Set aside for later use. (See **Figure 4**)

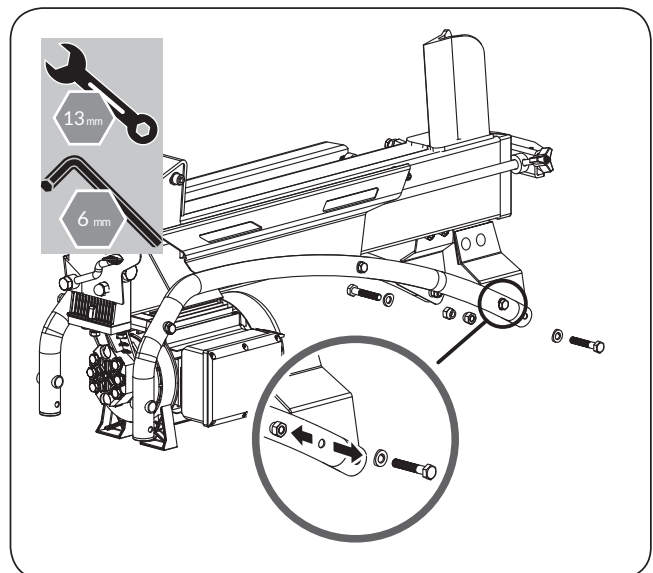

Figure 4

5. Insert the up end of the support legs into the support frame tube and line up the holes, then secure with the two M8x45 bolts, arc washers, and nuts that were removed in step 4 and the other M8x45 bolts, arc washers, and nuts. (See **Figure 5**)

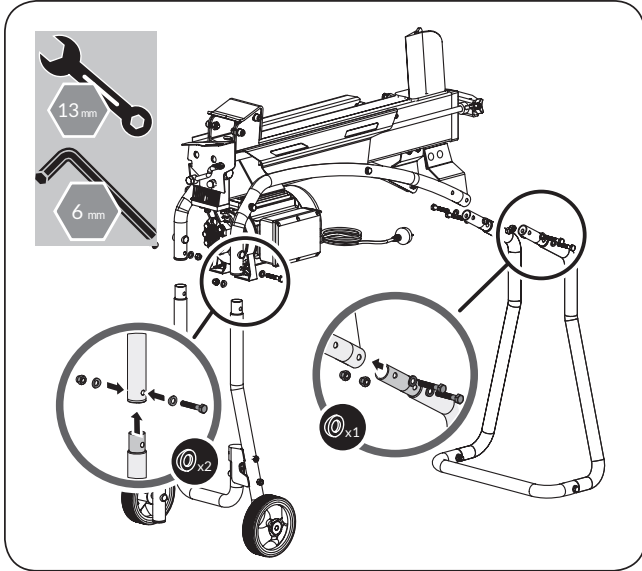

Figure 5

	M8 X 45	X 2	4
	M8 X 45	X 2	

6. Insert the log tray table and make sure the bolts hold the table. (See **Figure 6**)

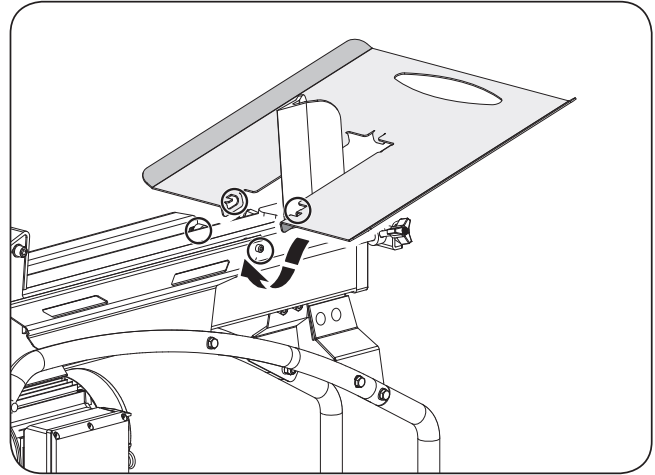

Figure 6



WARNING! Make sure that the log splitter is switched off and that the pressure plate has returned to its starting position before attaching the collector table.

KNOW YOUR MACHINE

FEATURES AND CONTROLS

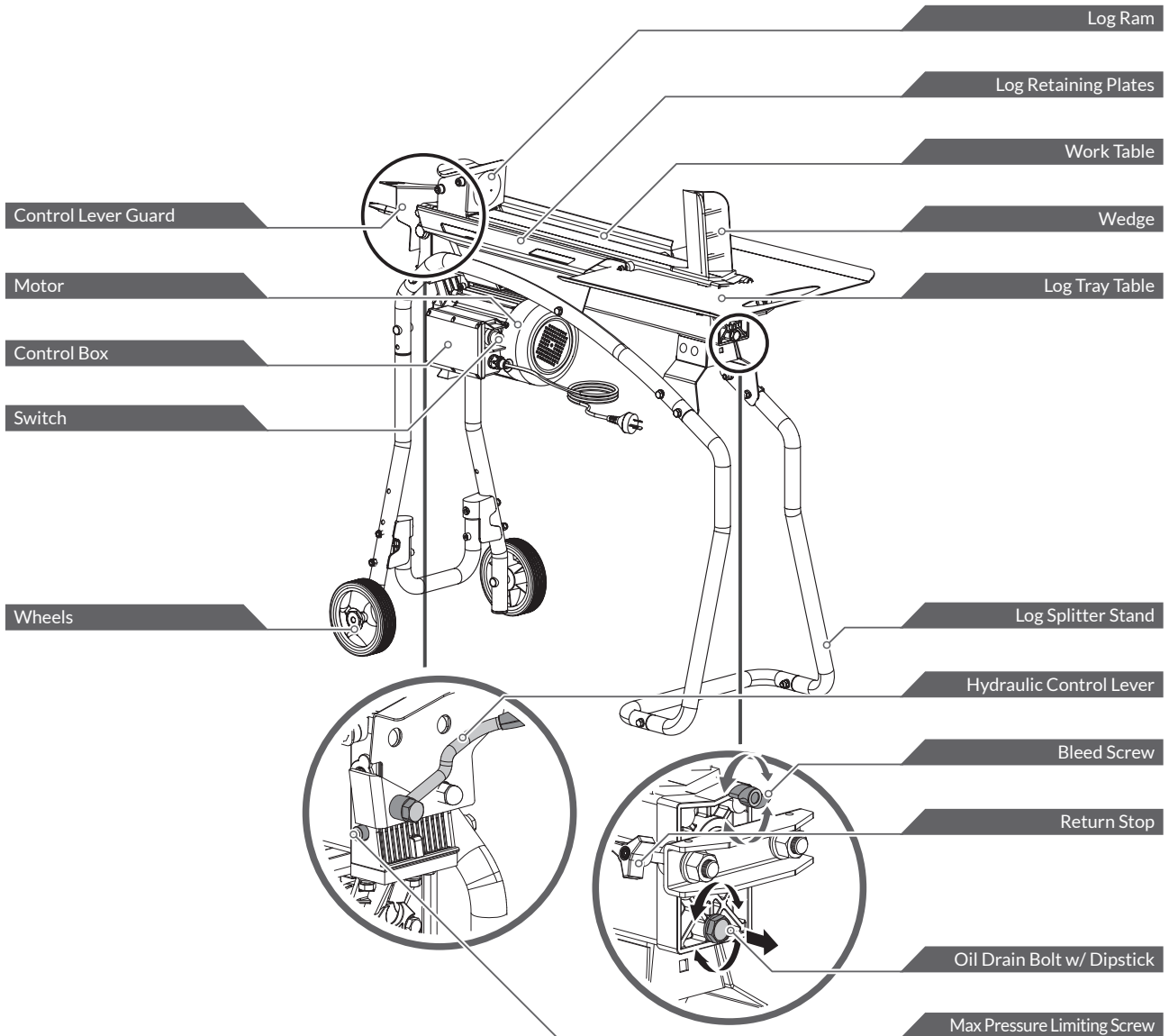

BLEED SCREW

- » Before operating your log splitter, the bleed screw should be loosened until air can go in and out of the oil tank smoothly.
- » Air flow through the bleed screw hole should be detectable when the log splitter is in use.
- » Before moving the log splitter, make sure the bleed screw is tightened to avoid oil leakage.



Failure to loosen the bleed screw will keep the sealed air in the hydraulic system compressed. Continuous air compression and decompression will blow out the seals of the hydraulic system and cause permanent damage to the log splitter.

MAX PRESSURE LIMITING SCREW

- » Max pressure was preset at the factory by a qualified mechanic using professional tools.
- » Unauthorized resetting will prevent the hydraulic pump from providing enough splitting pressure or **RESULT IN SERIOUS INJURY AS WELL AS DAMAGE TO THE MACHINE.**



Do not adjust the max pressure limiting screw!

OPERATION

OPERATING CONDITIONS

Your YARDMAX log splitter is designed to operate in temperatures between 40°F and 100°F and at altitudes of 3,200 feet above sea level. The surrounding humidity should be less than 50% at 100°F. It can be stored or transported in temperatures between -10°F and 130°F.

ELECTRICAL REQUIREMENTS

Confirm that you have a US Standard, 3 pin grounded, Type B 15 AMP (NEMA 5-15).

Check that the electric circuit is grounded, adequately protected, and that it corresponds with the power, voltage, and frequency of the motor.

STAKE ON LEVEL GROUND

To secure your YARDMAX log splitter, use two bolts or stakes on level ground. Due to varying ground surfaces, these are not included. Choose the right type of bolt or stake for your surface type or call us for a recommendation.

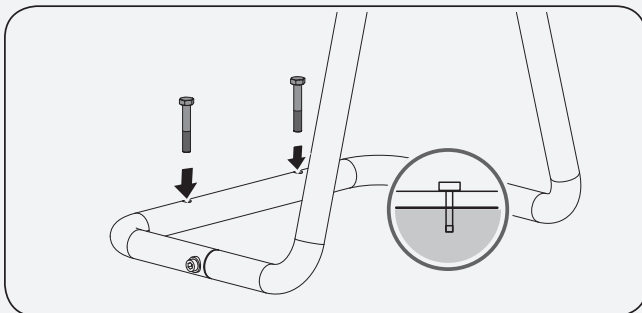

TWO HANDS OPERATION

For your safety, your log splitter is equipped with a “ZHB” control system that requires both hands of the operator. The left hand controls the hydraulic control lever while the right hand controls the pushbutton switch. The log splitter will stop if the lever or pushbutton are released. Only after the lever and pushbutton are released will the log ram return to its starting position.

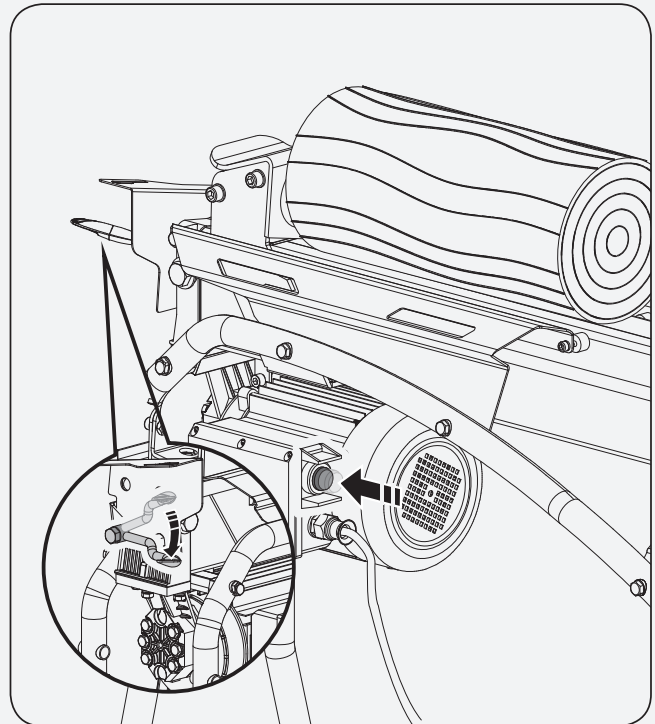

If the log does not begin to split after 5 seconds of operation, release both controls. The motor or hydraulic fluid may overheat and damage your log splitter.

SPLIT HARD WOOD

For extremely hard wood, rotate your log 90° to see whether it can be split in a different direction. If the log cannot be split, then its hardness exceeds the machine's capacity.

LOAD A LOG

When loading a log, place hands on the sides of the log, not the ends. Make sure logs will not twist, rock, or slip while being split.

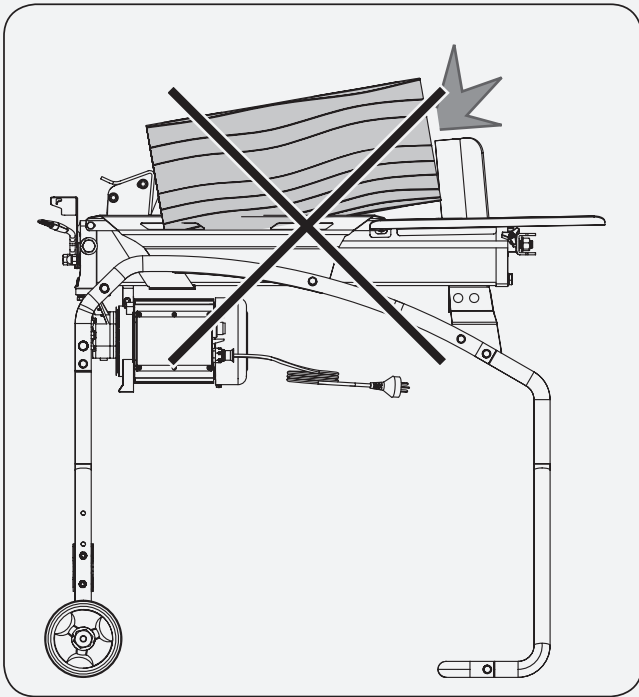

Do not split logs on the upper part of the blade. This could break the blade or damage the machine.

ADJUSTING THE RETURN STOP

If you are splitting a pile of shorter logs, you may want to prevent the pusher plate returning all the way back to start, this will speed up future operations.

To adjust how far the pusher plate comes back:

1. Extend the ram fully. When the ram is at full extension, release the push button switch.

- » Do not put any logs on the log splitter at this stage.
- » Keep the control lever pressed down to prevent the ram from returning.

2. Loosen the handwheel on the return stop.

- » Move the stop towards the splitter to shorten the stroke.

3. Slide the stop to the desired position.

4. Tighten the handwheel on the return stop to lock it into position.

5. Make sure your hands are clear of the ram, and release the control lever.

- » The ram should return as far as the stop will allow.

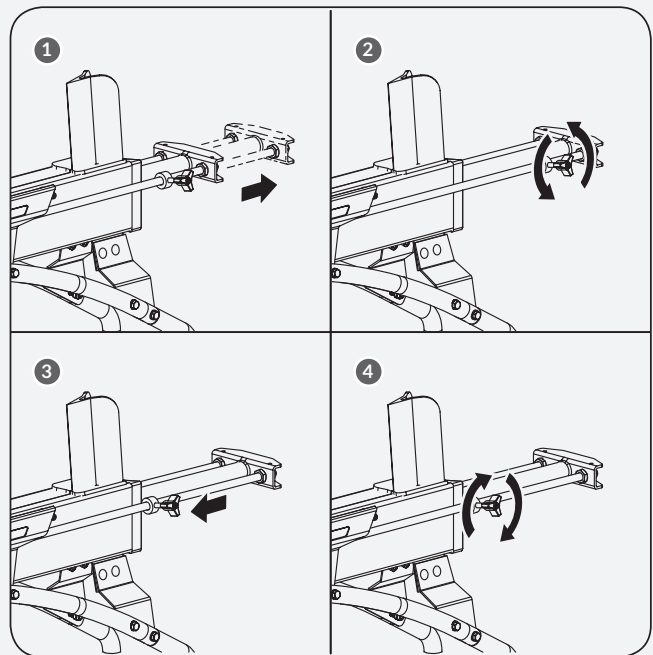

FREEING A JAMMED LOG

- Release both controls.
- After the log ram moves back to its starting position and completely stops, insert a wood wedge under the jammed log.

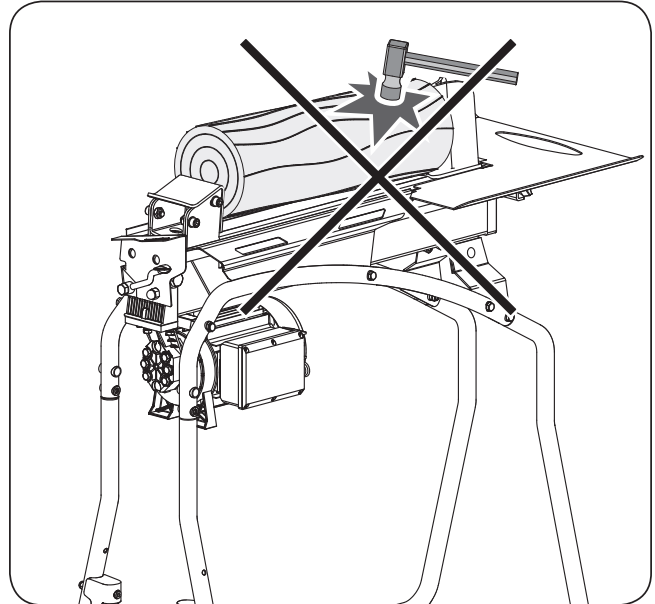
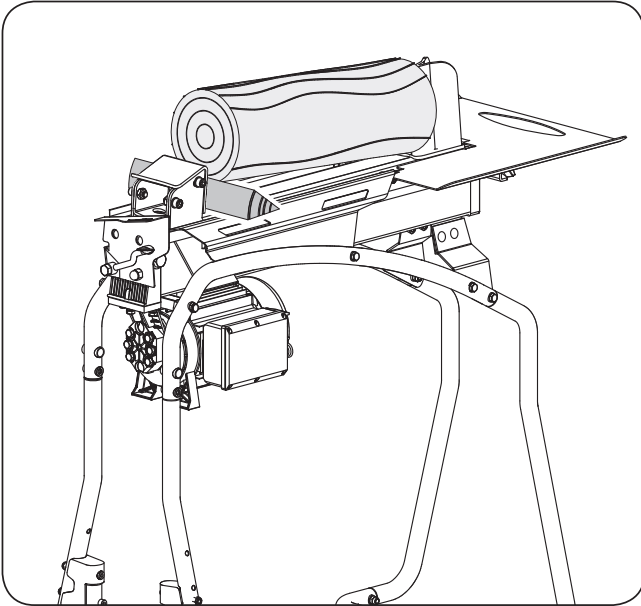

Never try to knock a jammed log off the splitter with your hand or another object. This could damage the tool or cause the log to fly up and hit someone.

- Start the log splitter to push the wood wedge completely under the jammed log.

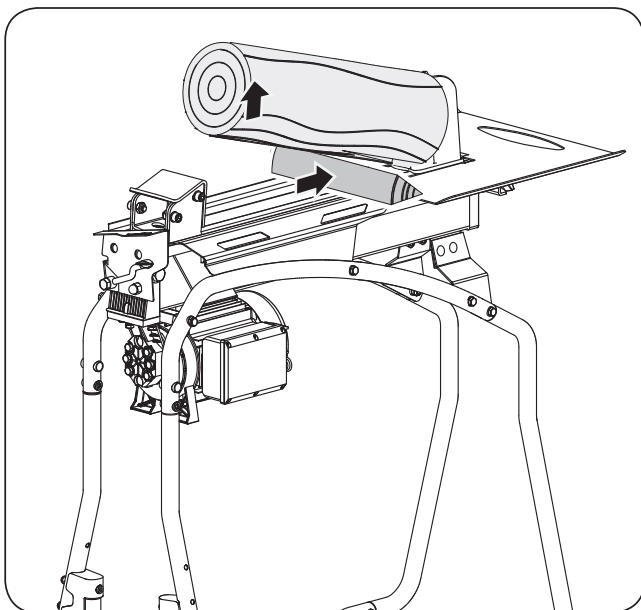

- Repeat above procedure with sharper-sloped wood wedge until the log is completely freed.

REPLACING HYDRAULIC OIL



Disassemble the log tray table before replacing the hydraulic oil.

Replace the hydraulic oil in your YARDMAX log splitter after every 150 hours of use. Follow these steps to replace it:

- Make sure all moving parts stop and the log splitter is unplugged.
- Unscrew the oil drain bolt with dipstick to remove it.

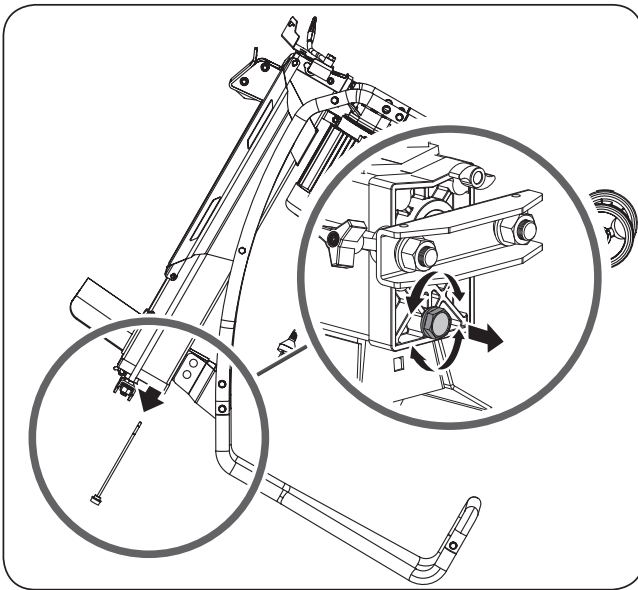

- Tip the log splitter so the motor end is higher than the oil drain plug, and drain oil over a 1-gallon container.

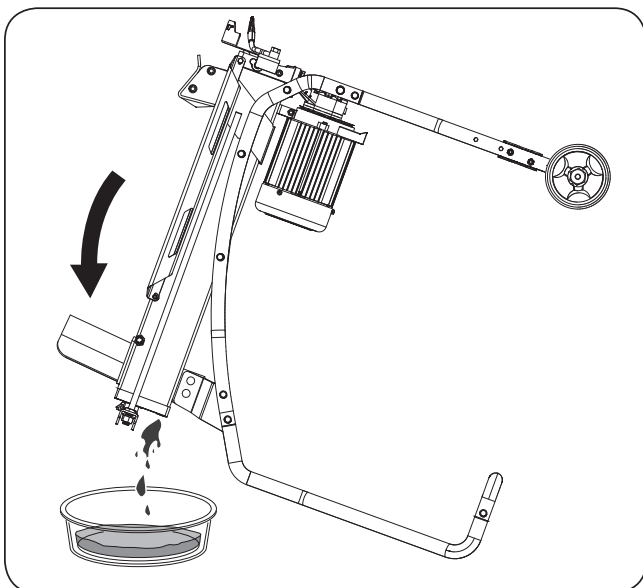

- Tip the log splitter so the oil drain plug is higher than the motor and refill with 3.7 quarts of fresh hydraulic oil.

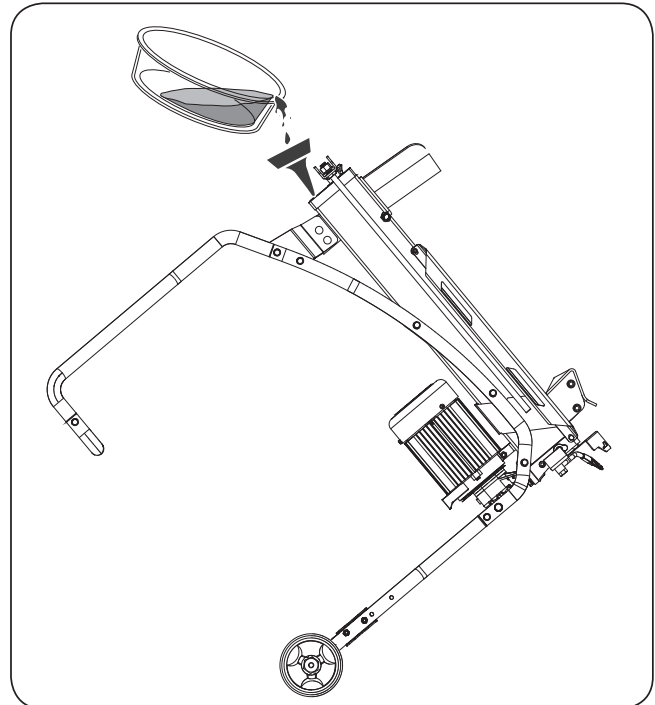

- Clean the surface of the dipstick and put it back in the oil tank while keeping the log splitter vertical.
- Make sure the level of the refilled oil is between the two grooves on the dipstick.

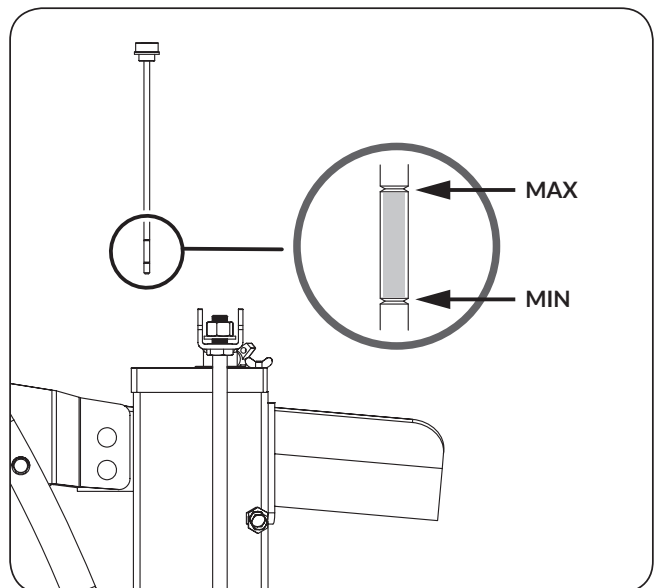

- Clean the oil drain bolt with dipstick before screwing it back in. Tighten it to avoid leakage before setting the log splitter down.

» Periodically check oil level to ensure it is between the two grooves on the dipstick. Refill with oil if it becomes low.

The following hydraulic oils or equivalents are recommended for your log splitter's hydraulic transmission system:

- 10W AW32
- ASLE H-150
- ISO 32

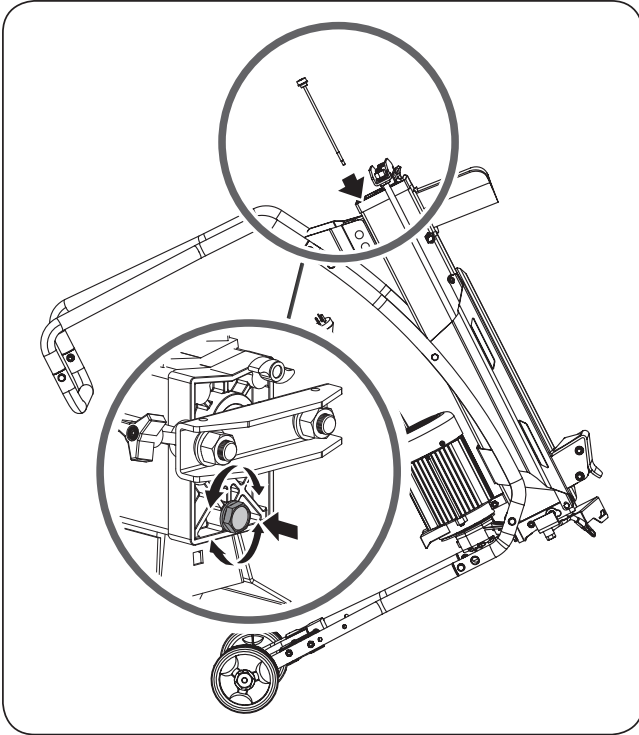

SHARPENING THE WEDGE

Over time your YARDMAX log splitter wedge will dull. If you notice decreased performance, we recommend sharpening the wedge using a fine-toothed file, smoothing any burrs or crushed areas along the cutting edge. For questions about sharpening the wedge, call us at 844-YARDMAX.

TROUBLESHOOTING

Problem	Cause	Remedy
Fails to split logs	<ol style="list-style-type: none"> 1. Log is improperly positioned 2. The sizes or hardness of the log exceeds the capacity of the machine 3. Wedge cutting edge is dull 4. Oil leaks 5. Adjustment was made on max pressure limiting screw 	<ol style="list-style-type: none"> 1. Refer to Log Splitter Operation section of this manual for proper log loading 2. Reduce the log sizes before splitting it on the log splitter 3. Refer to Sharpening the Wedge section to sharpen the cutting edge 4. Locate leak(s) and contact YARDMAX 5. Contact YARDMAX
Log ram moves inconsistently, making unfamiliar noises or vibrations	Lack of hydraulic oil and excessive air in the hydraulic system	<p>Check oil level for possible oil refilling</p> <p>Contact YARDMAX</p>
Oil leaks around stroke limiter or from other points	<ol style="list-style-type: none"> 1. Air sealed in hydraulic system while operating 2. Bleed screw is not tightened before moving the log splitter 3. Oil drain bolt with dipstick is not tight 4. Hydraulic control valve assembly and/or seal(s) worn 	<ol style="list-style-type: none"> 1. Loosen bleed screw by 3-4 rotations before operating the log splitter 2. Tighten the bleed screw before moving the log splitter 3. Tighten the oil drain bolt with dipstick 4. Contact YARDMAX
Ram moves slowly and stops prior to the end	Log splitter may not be level	Ensure the log splitter is on a level surface

WIRING DIAGRAM

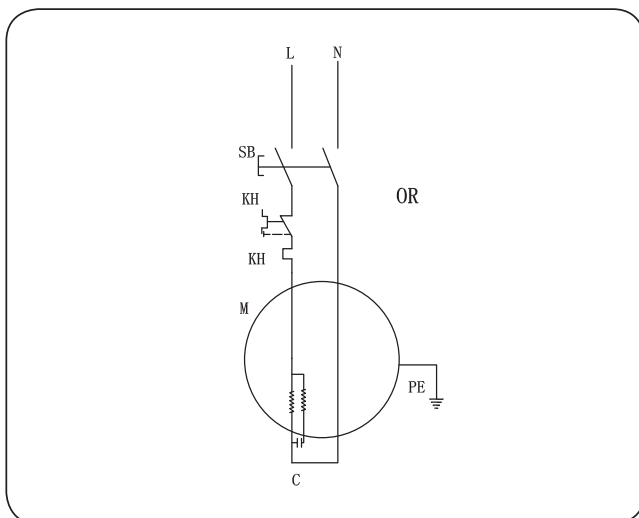

PLUMBING DIAGRAM

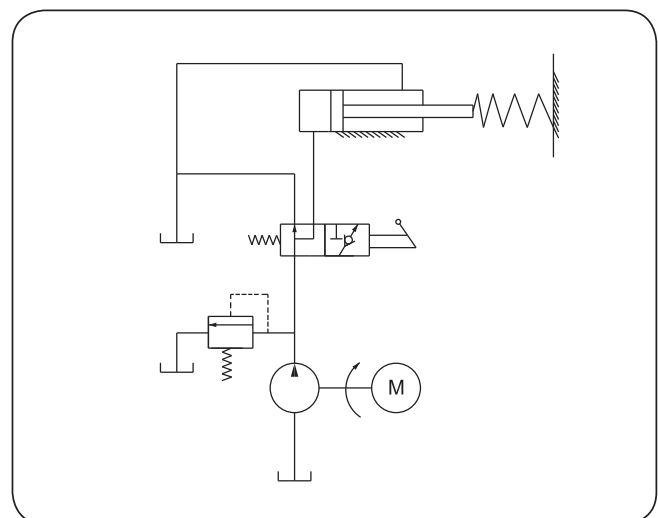

PARTS DIAGRAM

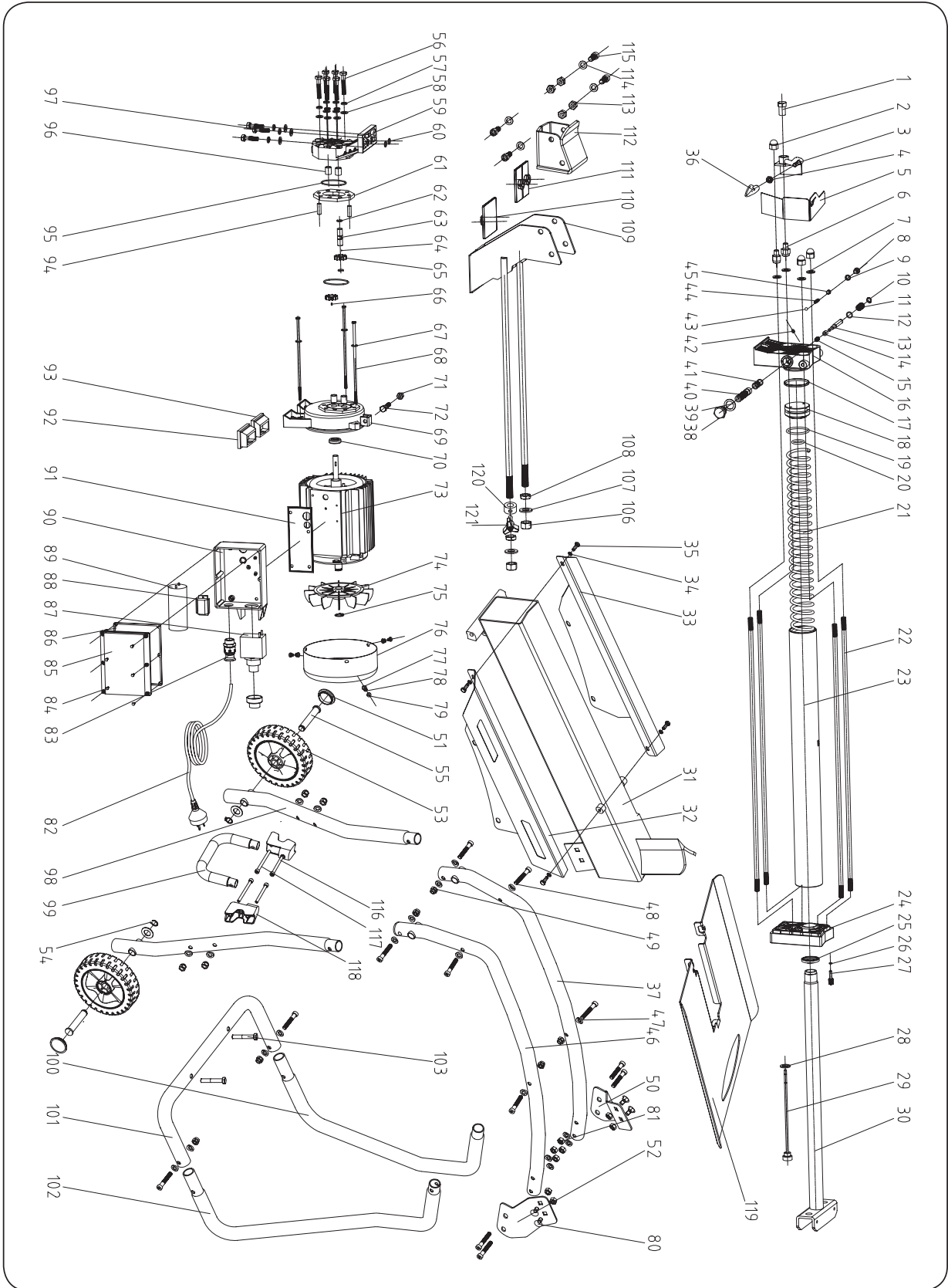

PARTS LIST

No.	Description	QTY.
1	Lever Mount Nut	1
2	Cap Nut M10	3
3	Lever	1
4	Nut M8	1
5	Lever Guard	1
6	Customized Nut	2
7	Copper Gasket 10	4
8	Safty Valve Bolt M8	1
9	O-Ring 5.5x2	1
10	Snap Washer 6	1
11	Valve Retract Spring	1
12	O-Ring 6x1.5	1
13	Valve Core Rod	1
14	Sliding Pressure Sensor Sleeve	1
15	Sliding Pressure Sensor Sleeve Spring	1
16	Alumium Cover- Rear	1
17	O-Ring 50x2.65	1
18	Piston	1
19	Piston Ring 55	1
20	O-Ring 32x3.5	1
21	Spring	1
22	Stud Bolt	4
23	Hydraulic Cylinder	1
24	Alumium Cover-Front	1
25	Piston Rod Seal 30	1
26	O-Ring 7x1.9	1
27-1	Wing Bolt	1
28	Wahser Groupware 14	1
29	Dipstick	1
30	Piston Rod	1

No.	Description	QTY.
31	Frame Tube	1
32	Lead Plank 1 - Left	1
33	Lead Plank 2 - Right	1
34	Washer 6	4
35-1	Screw M6x12	4
36	Lever Knob	1
37	Support Frame - Right	1
38	Drain Plug	1
39	Washer Groupware 16	1
40	Valve Sleeve	1
41	O-Ring 10x2	5
42	Adjusting Screw M5x8	1
43	Steel Ball 6	1
44	Safty Valve Spring	1
45	Adjusting Screw M8x8	1
46	Support Frame - Left	1
47	Arc Washer 30	18
48	Screw M8x45	12
49-1	Lock Nut M8	15
50	Support Stand Mounting Bracket - Right	1
51	Wheel Cap	2
52	Support Stand Mounting Bracket - Left	1
53	Wheel	2
54-1	Circlip 12	2
55-1	Wheel Pin	2
56	Bolt M8x55	6
57	Spring Washer 8	9
58	Washer 8	9
59	Gear Pump Cover	1
60	O-Ring 10.6x2.65	2

No.	Description	QTY.
61	Gear Housing Plate	1
62	Circlip 10	2
63	Gear Shaft	1
64	Steel Ball 2.5	1
65	Gear	2
66	Pin 2.5x4	1
67	Flat Washer 5	6
68-1	Bolt M5x180	3
69	Motor Cover	1
70	Oil Seal FB11x26x7	1
71	Nut M8	1
72	Screw M8x35	1
73	Motor	1
74	Fan	1
75	Circlip 17	1
76	Shroud	1
77	Flat Washer 5	6
78	Spring Washer 5	6
79-1	Screw M5x8	2
80	Bolt M8x16	4
81	Nut M8	8
82	Cable & Plug	1
83	Strain Relief	1
84-1	Screw M3.5x12	8
85	Switch Box Cover	1
86	Airproof Underlay	1
87-1	Switch	1
88-1	Cable briquetting	1
89	Capacitor	1
90	Switch Box	1

No.	Description	QTY.
91	Waterproof Underlay	1
92	Motor Support Left Shoe	1
93	Motor Support Right Shoe	1
94	Pin 8x24	2
95	O-Ring 46.2x1.8	2
96	Sliding Sleeve	4
97	Bolt M8x30	3
98	Rear Support Stand	2
99	Rear U-Shaped Connecting Pipe	1
100	Front Support Stand - Left	1
101	Front U-Shaped Connecting Pipe	1
102	Front Support Stand - Right	1
103	Bolt M8x50	2
104	Screw ST2.9X6.5	2
105	Guard board	1
106	Lock Nut M14	2
107	Flat Wahser 14	2
108	Nut M14	2
109	Log Pusher Connection Weldment	1
110	Plastic Insert - Lower	1
111	Plastic Insert - Upper	1
112	Log Pusher	1
113	Lock Nut M10	4
114	Flat Wahser 10	5
115	Screw M10x25	4
116	Screw M8x85	2
117	Screw M8x100	2
118	Support Bracket	2
119	Log Tray Table	1
120	Ring-shaped Nut	1
121	Handwheel	1

Tame the Great Outdoors™

