

ITEM NO.:A101011300

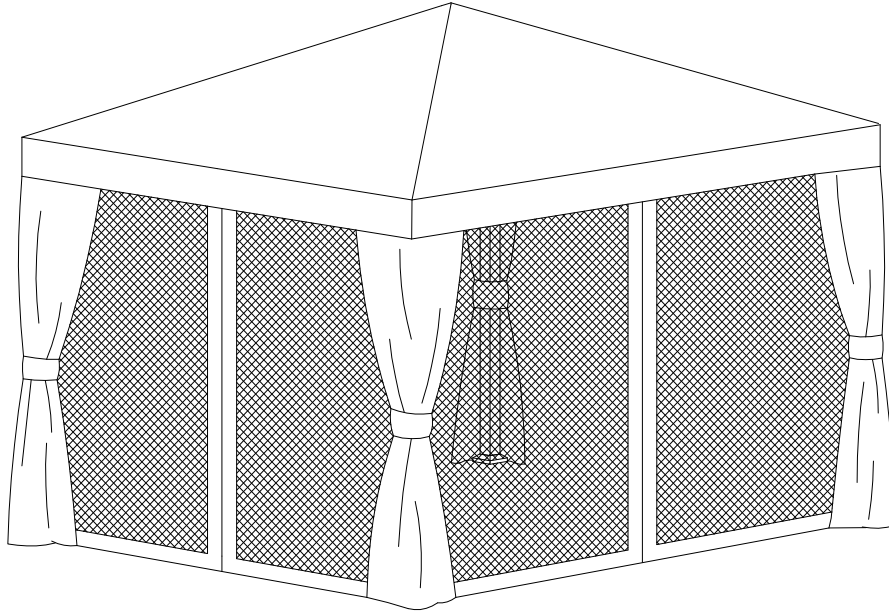

WE HAVE YOU IN MIND, LET US SERVE YOU!

Questions? Issues?

CONTACT US

24 hours / 7 days a week



www.sunjoyonline.com











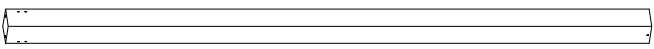



customer.care@sunjoygroup.com



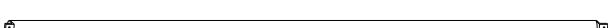
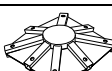

1-(866)-578-6569

Parts List

Post	A	4	P000200399	
Post Base	B	4	P000100299	
Base	C	4	P006100155	
Beam(1)	D	4	P000400811	
Beam(2)	E	4	P000400812	
Slanting Bar	F	8	P005000355	
Corner Connector	G	4	P000601225	
Big Top Beam	H	4	P000601224	
Mid Beam	I	4	P000601226	
Netting Bar	J	8	P005700600	
Big Top Connector	K1	1	P000501048	
Hook	L1	1	P005800001	
Large Canopy	M	1	P001100493	
Wall	N	1	P001300098	
Mosquito Netting	O	1	P001200195	

Hardware Pack 1

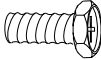
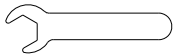
AA	M6x15 Screw	48 PCS	H010110005	
BB	M6 Flat Washer	72 PCS	H050010023	
CC	M6x15 Bolt	24 PCS	H010020011	
Z	M6 Wrench	1 PC	H090010009	

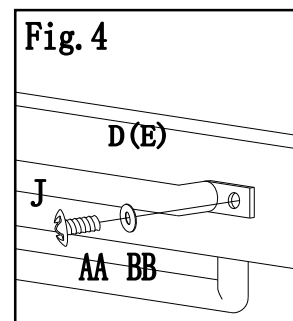
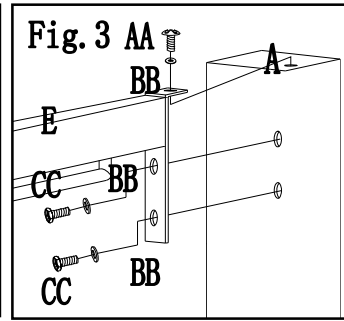
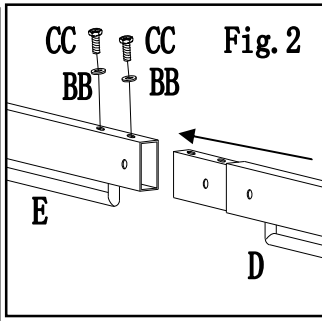
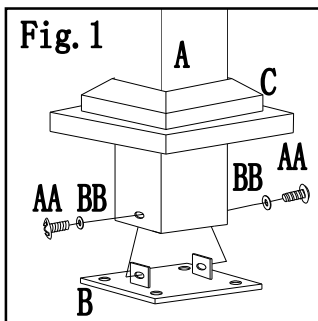
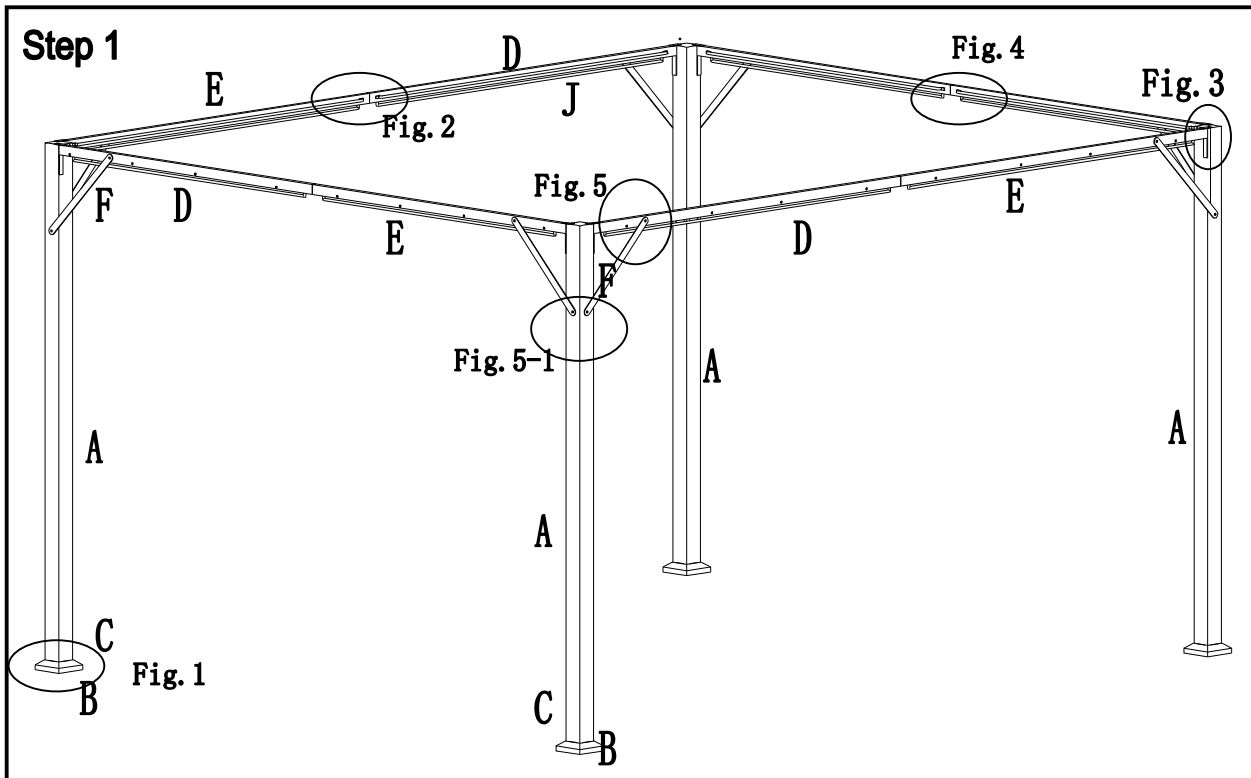

Fig.1: Tighten the Base protector (C) onto the Post (A), attach the Base (B) to Post (A) by using Screw (AA) and Flat Washer (BB).

Fig.2: Attach the Beam (D) to the Beam (E) by using Bolt (CC) and Flat Washer (BB).

Fig.3: Attach the well-connected Beam to the Post (A), assemble the Beam and the top of the Post (A) by using the Screw (AA) and the Flat Washer (BB).

Fig.4: Attach the Netting Bar (J) to the Beam (D and E) by using Screw (AA) and the Flat Washer (BB).

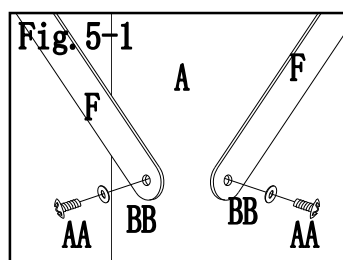
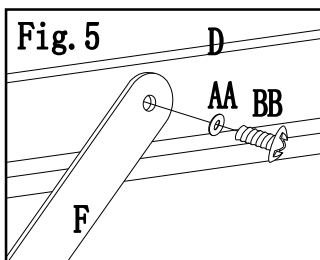



Fig.5, Fig.5-1: Attach the Slanting Bar (F) to the Beam and the Post (A) by using Screw (AA) and Flat Washer (BB).

Hardware Pack 2

AA	M6x15 Screw	8 PCS	H010110005	
BB	M6 Flat washer	8 PCS	H050010023	

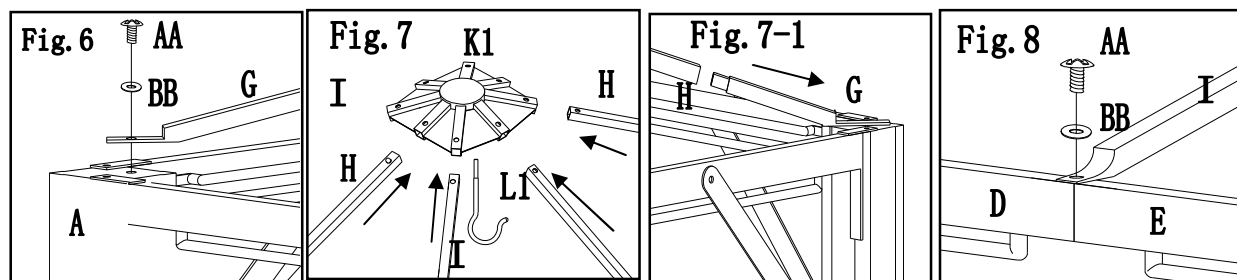
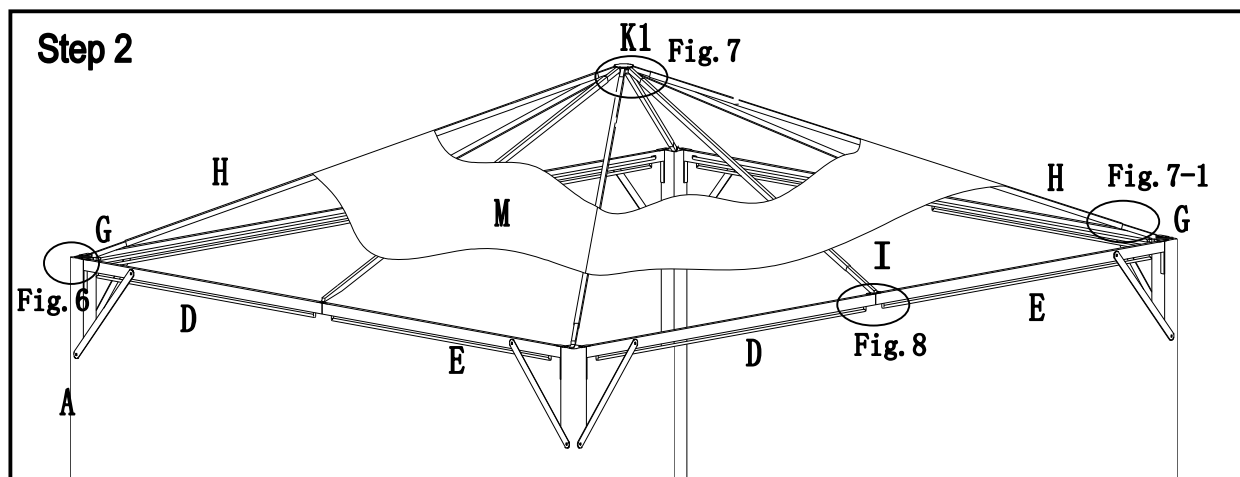

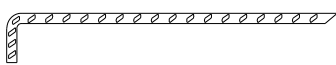

Fig.6: Attach the Corner Connector (G) to the top of Post (A) by using Screw (AA) and Flat Washer (BB).

Fig.7: Attach the Hook (L1) to the Big Top Connector (K1), Insert the Mid Beam (I) and the Beam (H) into the Big Top Connector (K).

Fig.7-1: Attach the Big Top Beam (H) to the Corner Connector (G).

Fig.8: Attach the Mid Beam (I) to the beam with the Screw (AA) and Flat Washer (BB).

Hardware Pack 3

FF	Φ6x230MM 7 stake	8 PCS	H070010008	
GG	Plastic Ring	96 PCS	P005800027	

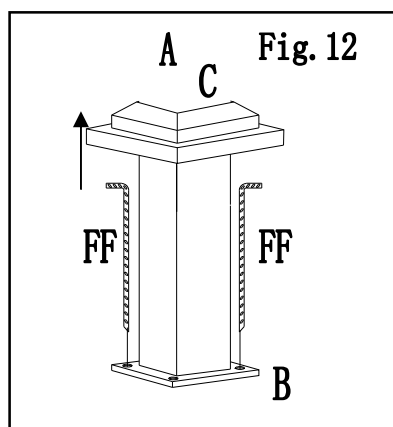
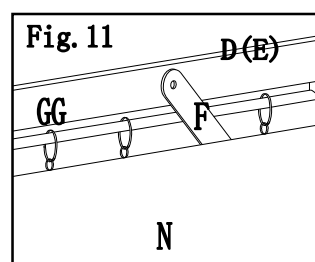
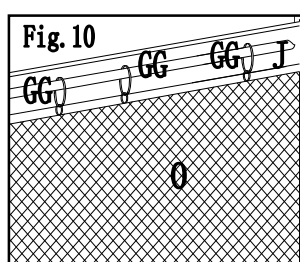
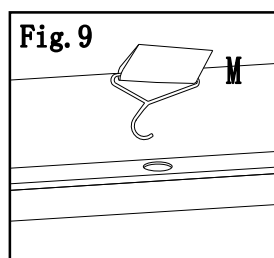
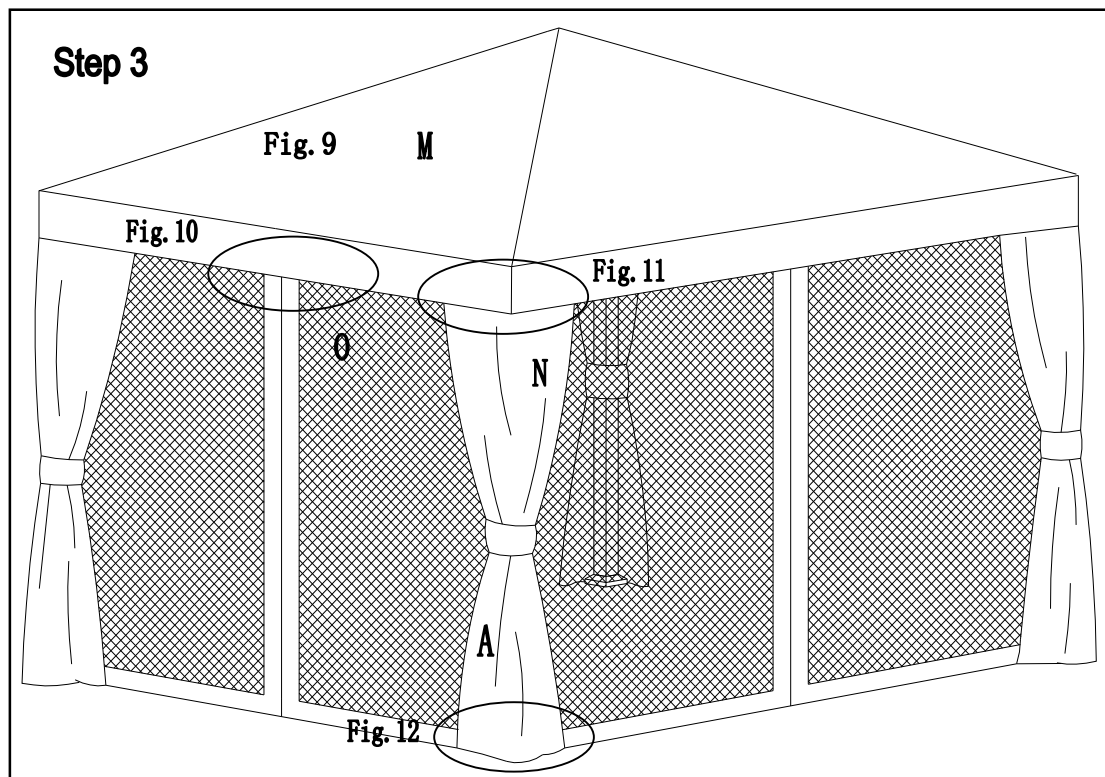

Fig.9: Spread the Large Canopy (M), hang the pothooks of the large canopy into the holes on the panels.

Fig.10: Hang Mosquito Netting (O) on the Netting Bar (J) by using the Plastic Ring (GG).

Fig.11: Hang the Wall (N) on the tube of the Beam(D、 E) by using the Plastic Ring (GG).

Fig.12: Up the Base (C), and assemble the assembled gazebo by using the Floor Nail (FF) and now your gazebo is ready for use.

Care and Maintenance

- Our steel components for garden accessories and furniture are treated with rust inhibiting paint that protects it from rusting. However, due to the nature of steel, surface oxidation (rusting) will occur once these protective coatings are scratched. This is not a defect and thus not covered by the warranty.
- To minimize this condition, we recommend care when assembling & handling the product to prevent scratching the paint. Should any scratching or damage occur, we recommend immediate touch-up with rust inhibiting paint.
- Surface rust can also be easily removed with a very light application of common cooking oil. If surface oxidation (rusting) occurs and if no measure is taken to prevent this, the oxidation may start dripping on to deck or patio and caused damaging stains, which may be difficult to remove. This can be prevented if the above-mentioned measures are taken to keep the product from oxidizing.
- Use damp cloth to wipe off the stains as quickly as possible.
- If necessary, wash with a mild solution of soap and water; rinse thoroughly and dry completely.
- Periodically check and ensure that all bolts are well-tighten during use

Limited Manufacturer's Warranty

Sunjoy Group warrants to the original purchaser that this item is free from defects in workmanship and materials for a period of **6 months** from the date of purchase, provided the item was factory-sealed at the time of purchase and is maintained with care and used only for personal, residential purposes. Should any manufacturing defect arise within this warranty period, Sunjoy Group will replace (at our option) any defective merchandise or parts upon proof of purchase; however, transportation and delivery costs, as well as payments to a third party for assembly or disassembly of the item, remain the responsibility of the purchaser. A purchaser of an "open box," previously-returned, or "clearance" item, as well as original purchasers outside of the warranty period, may obtain replacement parts from Sunjoy Group for products in current production, at nominal cost.

Exclusions:

Items used for commercial, contract, or other non-residential purposes, or items damaged due to acts of nature, vandalism, misuse, or improper assembly are not covered. Corrosion or rusting of hardware is not covered. Proof of purchase (dated register receipt) is required for warranty claims. Warranty is to the original purchaser and is non-transferable. Any replacement of warranted items will be in the original style and color, or a similar style and color if the original is unavailable or has been discontinued. As some states do not allow exclusions or limitations on an implied warranty, the above exclusions and limitations may not apply. This warranty gives you specific rights, and you may also have other rights, which vary from state to state.