



Operating Instructions and Parts Manual Step-Pulley Industrial Drill Presses

Models IDP-17 and IDP-22



IDP-22



IDP-17

JET
427 New Sanford Road
LaVergne, Tennessee 37086
Ph.: 800-274-6848
www.jettools.com

Part No. M-354300
Edition 4 02/2019
Copyright © 2017 JET



1.0 IMPORTANT SAFETY INSTRUCTIONS

READ ALL INSTRUCTIONS BEFORE USING THIS DRILL PRESS.

WARNING – To reduce risk of injury:

1. Read and understand entire owner's manual before attempting assembly or operation of this drill press.
2. Read and understand the warnings posted on the machine and in this manual.
3. Replace warning labels if they become obscured or removed.
4. This drill press is designed and intended for use by properly trained and experienced personnel only. If you are not familiar with the proper and safe operation of a drill press, do not use until proper training and knowledge have been obtained.
5. Do not use this drill press for other than its intended use. If used for other purposes, JET disclaims any real or implied warranty and holds itself harmless from any injury that may result from that use.
6. Always wear ANSI Z87.1 approved safety glasses or face shield while using this drill press. (Everyday eyeglasses only have impact resistant lenses; they are *not* safety glasses.)
7. Before operating this drill press, remove tie, rings, watches and other jewelry, and roll sleeves up past the elbows. Remove loose clothing and confine long hair. Non-slip footwear or anti-skid floor strips are recommended. Do **not** wear gloves.
8. Wear hearing protection (plugs or muffs) during extended periods of operation.
9. Do not operate this machine while tired or under the influence of drugs, alcohol or any medication.
10. Make certain the switch is in the **OFF** position before connecting the machine to the power supply. Turn off all controls before unplugging.
11. Make certain the machine is properly grounded. Connect to a properly grounded outlet only. See Grounding instructions.
12. Make all machine adjustments or maintenance with the machine unplugged from the power source.
13. Remove adjusting keys and wrenches. Form a habit of checking to see that keys and adjusting wrenches are removed from the machine before turning it on.
14. Keep safety guards in place at all times when the machine is in use. If removed for maintenance purposes, use extreme caution and replace the guards immediately after maintenance is complete.
15. Check damaged parts. Before further use of the machine, a guard or other part that is damaged should be carefully checked to determine that it will operate properly and perform its intended function. Check for alignment of moving parts, binding of moving parts, breakage of parts, mounting and any other conditions that may affect its operation. A guard or other part that is damaged should be properly repaired or replaced.
16. Provide for adequate space surrounding work area and non-glare, overhead lighting.
17. Keep the floor around the machine clean and free of scrap material, oil and grease.
18. Keep visitors a safe distance from the work area. **Keep children away.**
19. Make your workshop child proof with padlocks, master switches or by removing starter keys.
20. Give your work undivided attention. Looking around, carrying on a conversation and "horse-play" are careless acts that can result in serious injury.
21. The drill press is intended for indoor use. To reduce the risk of electric shock, do not use outdoors or on wet surfaces.
22. Do not handle plug or machine with wet hands.
23. Use recommended accessories; improper accessories may be hazardous.
24. Maintain tools with care. Follow instructions for lubricating and changing accessories.
25. Turn off machine and disconnect from power before cleaning. Use a brush or compressed air to remove chips or debris; do not use bare hands.
26. Never leave the machine running unattended. Turn the power off and do not leave the machine until it comes to a complete stop.
27. Do not stand on the machine. Serious injury could occur if the machine tips over.
28. Make sure the workpiece is securely attached or clamped to the table. Never use your hand to hold the workpiece – the bit may seize in the workpiece and rotate, causing injury.

29. Secure the drill press to the floor if there is any tendency for it to tip over, walk or slide during operation.
30. The drill press is intended for industrial use only.
31. Use proper extension cord. Make sure your extension cord is in good condition. When using an extension cord, be sure to use one heavy enough to carry the current your product will draw. An undersized cord will cause a drop in line voltage resulting in loss of power and overheating. Table 1 (sect. 7.3) shows correct size to use depending on cord length and nameplate ampere rating. If in doubt, use the next heavier gage. The smaller the gage number, the heavier the cord.

⚠ WARNING: This product can expose you to chemicals including lead which is known to the State of California to cause cancer and birth defects or other reproductive harm. For more information go to <http://www.p65warnings.ca.gov>.

⚠ WARNING: Some dust, fumes and gases created by power sanding, sawing, grinding, drilling, welding and other construction activities contain chemicals known to the State of California to cause cancer and birth defects or other reproductive harm. Some examples of these chemicals are:

- lead from lead based paint
- crystalline silica from bricks, cement and other masonry products
- arsenic and chromium from chemically treated lumber

Your risk of exposure varies, depending on how often you do this type of work. To reduce your exposure to these chemicals, work in a well-ventilated area and work with approved safety equipment, such as dust masks that are specifically designed to filter out microscopic particles. For more information go to <http://www.p65warnings.ca.gov/> and <http://www.p65warnings.ca.gov/wood>.

Familiarize yourself with the following safety notices used in this manual:

⚠ CAUTION

This means that if precautions are not heeded, it may result in minor injury and/or possible machine damage.

⚠ WARNING

This means that if precautions are not heeded, it may result in serious, or possibly even fatal, injury.

SAVE THESE INSTRUCTIONS

2.0 On-off switch padlock

To avoid accidental starting by young children or others not qualified to use the tool, the use of a padlock (not provided) is required.

To lock out the on-off switch (Figure 2-1):

1. Open padlock.
2. Insert through hole in switch guard.
3. Close padlock.
4. Store key in a safe place out of the reach of children.

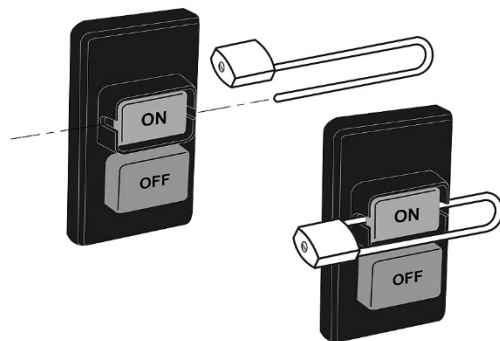

Figure 2-1

3.0 About this manual

This manual is provided by JET, covering the safe operation and maintenance procedures for a JET Model IDP-17 and IDP-22 Drill Press. This manual contains instructions on installation, safety precautions, general operating procedures, maintenance instructions and parts breakdown. The drill press has been designed and constructed to provide consistent, long-term operation if used in accordance with the instructions as set forth in this document.

If there are questions or comments, please contact your local supplier or JET. JET can also be reached at our web site: www.jettools.com.

Retain this manual for future reference. If the machine transfers ownership, the manual should accompany it.

4.0 Table of contents

| Section | Page |
|--|------|
| 1.0 IMPORTANT SAFETY INSTRUCTIONS | 2 |
| 2.0 On-off switch padlock | 3 |
| 3.0 About this manual | 4 |
| 4.0 Table of contents | 4 |
| 5.0 Specifications | 5 |
| 5.1 Base mounting hole dimensions | 6 |
| 6.0 Setup and assembly | 7 |
| 6.1 Unpacking and cleanup | 7 |
| 6.2 Shipping contents | 7 |
| 6.3 Tools required for assembly: | 7 |
| 6.4 Assembly | 7 |
| 7.0 Electrical connections | 8 |
| 7.1 GROUNDING INSTRUCTIONS | 8 |
| 7.2 Voltage conversion | 8 |
| 7.3 Extension cords | 9 |
| 8.0 Adjustments | 9 |
| 8.1 Depth stop adjustment | 9 |
| 8.2 Changing spindle speeds | 9 |
| 8.3 Return spring adjustment | 10 |
| 8.4 Table tilt adjustment | 10 |
| 9.0 Operating controls | 10 |
| 10.0 Operation | 10 |
| 11.0 User-maintenance | 11 |
| 11.1 Lubrication | 11 |
| 11.2 Belt replacement | 11 |
| 12.0 Spindle speed charts | 12 |
| 12.1 Speed selection for IDP-17 Drill Press | 12 |
| 12.2 Speed selection for IDP-22 Drill Press | 12 |
| 13.0 Troubleshooting IDP-17, IDP-22 | 13 |
| 14.0 Replacement Parts | 14 |
| 14.1.1 IDP-17 Drill Press – Exploded View | 15 |
| 14.1.2 IDP-17 Drill Press – Parts List | 16 |
| 14.2.1 IDP-22 Drill Press – Exploded View | 18 |
| 14.2.2 IDP-22 Drill Press – Parts List | 19 |
| 15.0 Electrical Connections for IDP-17, IDP-22 | 21 |
| 16.0 Warranty and service | 22 |

5.0 Specifications

| | | |
|--------------------|-------------|-------------|
| Model number | IDP-17..... | IDP-22..... |
| Stock number | 354300..... | 354301..... |

Motor and electricals:

| | | |
|---|---|---------------------------------------|
| Motor type..... | totally enclosed fan cooled, induction, capacitor start | |
| Horsepower | 1 HP..... | 1-1/2 HP..... |
| Phase | single..... | |
| Voltage | 115/230V (prewired 115V)..... | 115/230V (prewired 115V)..... |
| Cycle | 60Hz..... | |
| Listed FLA (full load amps)..... | 17.2 A..... | 12.4 A..... |
| Starting amps | 9.0 A..... | 7.4 A..... |
| Running amps (no load) | 8.9 A..... | 7.6 A..... |
| Start capacitor | 300 MFD 125VAC..... | 400 MFD 125VAC..... |
| Run capacitor | 30µF 250VAC..... | 40µF 250VAC..... |
| Power transfer | v-belt..... | |
| On/off switch..... | push button..... | |
| Motor speed..... | 1720 RPM..... | |
| Main power cord | 18 AWG, 6 ft. (183 cm) with plug..... | 14AWG, 6 ft. (183 cm) with plug..... |
| Work lamp power cord..... | 18 AWG, 6 ft. (183 cm) with plug..... | 18 AWG, 6 ft. (183 cm) with plug..... |
| Recommended circuit size ¹ | 20A..... | |
| Sound emission | 70 dB at 40 in. without load..... | |
| Work lamp | 110V to 12V..... | |

Head and Capacities:

| | | |
|---|---------------------------|---------------------------|
| Swing ² | 16-7/8 in. (430 mm)..... | 21-7/8 in. (560 mm)..... |
| Chuck style and shank capacity | keyed, 5/8" (16mm)..... | |
| Chuck arbor taper..... | JT-3 to MT2..... | |
| Spindle taper | MT2..... | MT3..... |
| Spindle travel, maximum | 3-5/16 in. (85 mm)..... | 4-13/16 in. (122 mm)..... |
| Spindle travel per one revolution of handle | 3 in. (78 mm)..... | 4-1/2 in. (115 mm)..... |
| Quill diameter | 2-1/16 in. (52 mm)..... | 2-5/8 in. (62 mm)..... |
| Number of spindle speeds..... | 12..... | |
| Maximum no-load speed range | 350 to 2800 RPM..... | 175 to 3050 RPM..... |
| Maximum spindle to table distance..... | 30-1/2 in. (775 mm)..... | 28 in. (710 mm)..... |
| Maximum spindle to base distance..... | 50 in. (1270 mm)..... | 48-1/2 in. (1230 mm)..... |
| Maximum chuck to table distance..... | 27 in. (686 mm)..... | 24-1/2 in. (622 mm)..... |
| Maximum chuck to base distance..... | 46-1/2 in. (1181 mm)..... | 39 in. (990 mm)..... |
| Drilling capacity, cast iron..... | 3/4 in. (20 mm)..... | 1-1/4 in. (32 mm)..... |
| Drilling capacity, mild steel | 5/8 in. (16 mm)..... | 1 in. (25 mm)..... |
| Work lamp | LED, adjustable..... | |

Materials:

| | | |
|--------------|-------------------------------|-------------------------------|
| Head | cast iron..... | cast iron..... |
| Table | surface-ground cast iron..... | surface-ground cast iron..... |
| Column | steel..... | steel..... |
| Base | cast iron..... | cast iron..... |

Table:

| | | |
|--|---------------------------------|---|
| Table size | 14 x 14 in. (355 x 355 mm)..... | 18-5/8 x 16-1/8 in. (473 x 410 mm)..... |
| Table slots, number of..... | 2..... | |
| Table slots, general size (WxD)..... | 1/2 x 1 in. (13 x 25.4 mm)..... | 5/8 x 1 in. (16 x 25.4 mm)..... |
| T-slot dimensions (WxD) | 3/4 x 3/8 in. (19 x 9.5mm)..... | 1 x 3/8 in. (25.4 x 9.5 mm)..... |
| Distance between slots (centers)..... | 3-7/8 in. (98 mm)..... | 3-1/2 in. (91 mm)..... |
| Table tilt..... | 45 deg. L and R..... | |
| Table rotation around column | 360 deg..... | |
| Table elevating system | worm gear with rack..... | |
| Recommended maximum weight on table..... | 110 lb. (50 kg)..... | 176 lb. (80 kg)..... |

¹ Subject to local and national electrical codes

² Swing is twice the distance from column to spindle center (i.e., the maximum diameter of workpiece that can be drilled to its center).

Base and Column:

| | | |
|---|--|---|
| Base size (LxWxH) | 21-3/4 x 13-3/4 x 2-3/16 in. | 22-5/8 x 19-7/16 x 3-3/8 in. |
| | (553 x 350 x 56 mm) | (575 x 494 x 86 mm) |
| Base working surface | 16-15/16 x 10-13/16 in. (430 x 275 mm) | 21-1/2 x 18-5/16 in. (545 x 465 mm) |
| Base slots, number of | 2 | 2 |
| Base slots, general size (WxD) | 1/2 x 1 in. (13 x 25.4 mm) | 5/8 x 1 in. (16 x 25.4 mm) |
| T-slot dimensions (WxD) | 3/4 x 3/8 in. (19 x 9.5mm) | 1 x 3/8 in. (25.4 x 9.5 mm) |
| Distance between base slots (centers) | 5-7/8 in. (149 mm) | 9-3/4 in. (238 mm) |
| Column diameter | 3-1/8 in. (80 mm) | 3-5/8 in. (92 mm) |

Dimensions and Weights:

| | | |
|-------------------------------------|-------------------------------|-----------------------------------|
| Overall dimensions, assembled | 27-1/2 x 15-3/4 x 63 in. | 35 x 19 x 67 in. |
| | (700 x 400 x 1600 mm) | (890 x 480 x 1700 mm) |
| Shipping dimensions | 31-1/2 x 16-3/4 x 70 in. | 36-5/8 x 20-7/8 x 74-1/2 in. |
| | (800 x 425 x 1780 mm) | (930 x 530 x 1890 mm) |
| Net weight (approximate) | 231 lb. (105 kg) | 319 lb. (145 kg) |
| Shipping weight (approximate) | 260 lb. (118 kg) | 364 lb. (165 kg) |

L = length; W = width; H= height; D= depth

The specifications in this manual were current at time of publication, but because of our policy of continuous improvement, JET reserves the right to change specifications at any time and without prior notice, without incurring obligations.

5.1 Base mounting hole dimensions

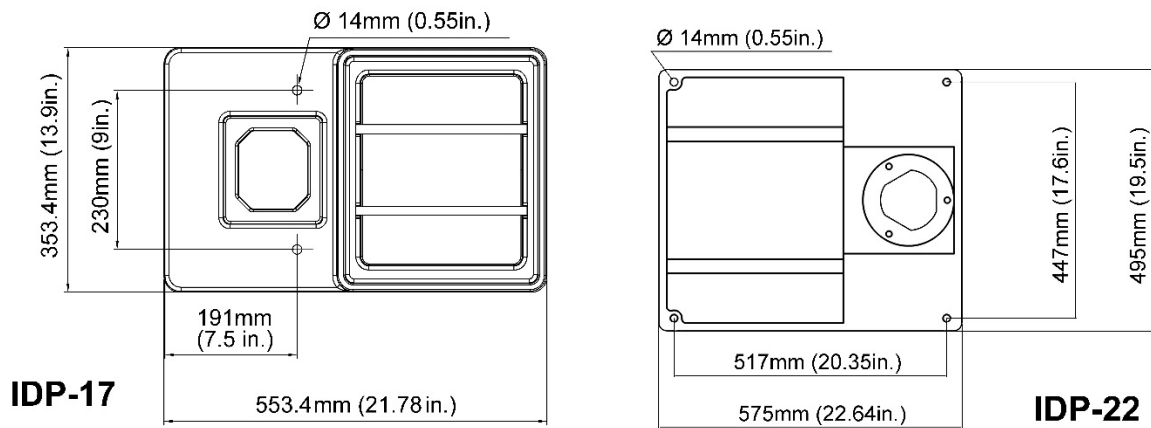

Figure 5-1: Base hole patterns

⚠WARNING

Read and understand the entire contents of this manual before attempting assembly or operation. Failure to comply may cause serious injury.

6.0 Setup and assembly

6.1 Unpacking and cleanup

Remove all contents from shipping carton and compare parts to the contents list in this manual. If shipping damage or any part shortages are identified, contact your distributor. Do not discard carton or packing material until drill press is assembled and running satisfactorily.

Clean all rust protected surfaces with kerosene or a light solvent. Do not use lacquer thinner, paint thinner or gasoline, as these can damage plastic components and painted surfaces.

6.2 Shipping contents

Carton contents

- 1 Drill press
- 1 Crank handle
- 3 Feed handles
- 1 Chuck and key
- 1 Arbor
- 1 Wrench
- 1 Drift key
- 2 Hex wrenches – 3mm, 5mm
- 1 Owner's manual
- 1 Warranty registration card

6.3 Tools required for assembly:

- 3mm hex wrench (provided)
- Rubber mallet

6.4 Assembly

1. Install 3 feed handles into hub (D, Figure 6-2).
2. Install crank handle on shaft of table bracket, and tighten set screw with 3mm hex wrench. (Figure 6-1)

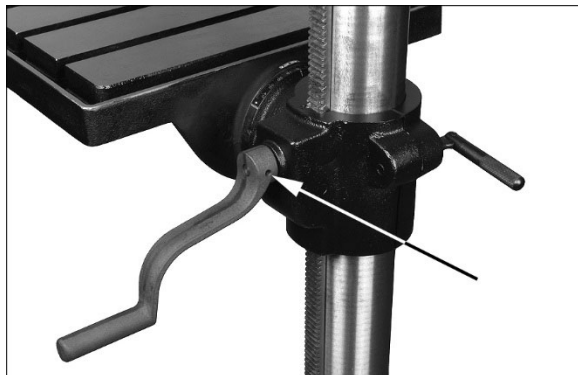

Figure 6-1: installing crank handle

6.4.1 Chuck and arbor installation

1. Thoroughly clean arbor (A, Figure 6-2), chuck (B) and spindle (C). Any grease or residue in these areas can cause the pieces to separate and create a safety hazard as well as damage to the tool.
3. Twist chuck to retract chuck jaws if they are exposed.
4. Push chuck (B) by hand onto arbor (A), and slide assembly firmly up into spindle (C).
5. Turn arbor and chuck assembly until tang (A₁) on arbor engages slot at end of spindle.
6. Use one or two sharp taps from a rubber mallet, or a hammer and a block of wood, against bottom of chuck to seat chuck securely onto arbor.

⚠CAUTION

Do not use a steel hammer directly against chuck, as this may damage chuck.

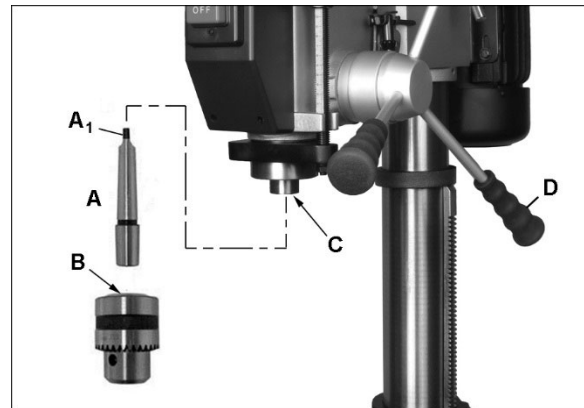

Figure 6-2: installing chuck and arbor

6.4.2 Chuck and arbor removal

1. Unplug machine from power source.
2. Raise table until it is about seven inches below chuck.
3. Place a piece of scrap wood on table, and lower quill (Figure 6-3) using feed handles.
4. Rotate spindle to align keyhole in spindle with keyhole in quill.
5. Insert drift key (E, Figure 6-3) into aligned slots and tap lightly. The chuck and arbor assembly should fall from the spindle.

⚠CAUTION

Catch chuck as it is released; allowing it to fall to floor may damage it.

6.4.3 Wrench and key storage

Wrenches, chuck key, and drift key can be stored on fixture on right side of drill press head.

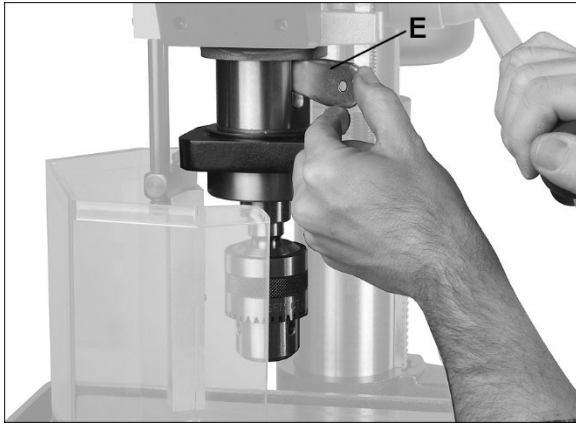

Figure 6-3: drift key insertion

7.0 Electrical connections

⚠WARNING All electrical connections must be done by a qualified electrician in compliance with all local codes and ordinances. Failure to comply may result in serious injury.

The IDP-17 and IDP-22 Drill Presses are rated at 115/230V power, and are pre-wired for 115 volt. The drill press comes with a plug designed for use on a circuit with a *grounded outlet* that looks like the one pictured in **A**, Figure 7-1.

Before connecting to power source, be sure switch is in *off* position.

It is recommended that the drill press be connected to a dedicated 20 amp circuit with circuit breaker or fuse. If connected to a circuit protected by fuses, use time delay fuse marked “D”. **Local codes take precedence over recommendations.**

7.1 GROUNDING INSTRUCTIONS

This tool must be grounded. In the event of a malfunction or breakdown, grounding provides a path of least resistance for electric current to reduce the risk of electric shock. This tool is equipped with an electric cord having an equipment-grounding conductor and a grounding plug. The plug must be inserted into an appropriate outlet that is properly installed and grounded in accordance with all local codes and ordinances.

⚠WARNING Improper connection of the equipment-grounding conductor can result in a risk of electric shock. Check with a qualified electrician or service person if you are in doubt as to whether the outlet is properly grounded. Do not modify the plug provided with the tool – if it will not fit the outlet, have a proper outlet installed by a qualified electrician.

The conductor with insulation having an outer surface that is green with or without yellow stripes is the equipment-grounding conductor. If repair or replacement of the electric cord or plug is

necessary, do not connect the equipment-grounding conductor to a live terminal.

Use only 3-wire extension cords that have 3-prong grounding plugs and 3-pole receptacles that accept the tool's plug.

Repair or replace damaged or worn cord immediately.

When operated at **115-volt**, this tool is intended for use on a circuit that has an outlet that looks like the one illustrated in **A**, Figure 7-1. An adapter, shown in **B** and **C**, may be used to connect this plug to a 2-pole receptacle as shown in **B** if a properly grounded outlet is not available. The temporary adapter should be used only until a properly grounded outlet can be installed by a qualified electrician. The green-colored rigid ear, lug, and the like, extending from the adapter must be connected to a permanent ground such as a properly grounded outlet box. **Note:** In Canada, the use of a temporary adaptor is not permitted by the Canadian Electrical Code, C22.1.

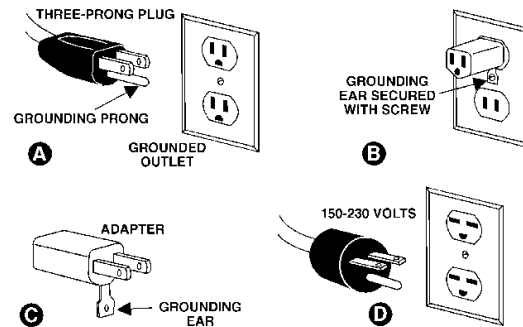

Figure 7-1: grounding

When operated at **230-volt**, this tool is intended for use on a circuit that has an outlet that looks like the one illustrated in **D**, Figure 7-1. The tool has a grounding plug that looks like the plug illustrated in **D**. Make sure the tool is connected to an outlet having the same configuration as the plug. No adapter is available or should be used with this tool. If the tool must be reconnected for use on a different type of electric circuit, the reconnection should be made by qualified service personnel; and after reconnection, the tool should comply with all local codes and ordinances.

7.2 Voltage conversion

Conversion from 115V to 230V must be done by a qualified electrician.

The Drill Press is prewired for 115 volt. To change incoming leads for 230 volt operation:

1. Open motor junction box cover, and change leads based on wiring diagram inside cover. This diagram is also shown in Figure 7-2. (NOTE: In case of discrepancy, diagram inside junction box cover takes precedence.)

2. Reinstall cover.
3. The plug on end of main power cord must be replaced with a UL/CSA listed plug rated for 230 volt operation.

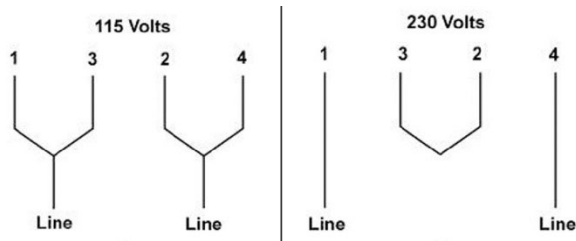

Figure 7-2: voltage conversion

7.3 Extension cords

The use of extension cords is discouraged; try to position machines near the power source. If an extension cord is necessary, make sure it is in good condition. When using an extension cord, be sure to use one heavy enough to carry the current your product will draw. An undersized cord will cause a drop in line voltage resulting in loss of power and overheating. Table 1 shows correct size to use depending on cord length and nameplate ampere rating. If in doubt, use the next heavier gauge. The smaller the gauge number, the heavier the cord.

| Amp Rating | | Volts | Total length of cord in feet | | | |
|------------|---------------|-------|------------------------------|-----|-----------------|-----|
| More Than | Not More Than | 120 | 25 | 50 | 100 | 150 |
| | | 240 | 50 | 100 | 200 | 300 |
| | | | AWG | | | |
| 0 | 6 | | 18 | 16 | 16 | 14 |
| 6 | 10 | | 18 | 16 | 14 | 12 |
| 10 | 12 | | 16 | 16 | 14 | 12 |
| 12 | 16 | | 14 | 12 | Not Recommended | |

Table 1: Extension cord recommendations

8.0 Adjustments

8.1 Depth stop adjustment

To drill multiple holes at the same preset depth, use the depth stop:

1. Make a pencil mark on edge of workpiece to indicate depth of hole.
2. With drill bit in chuck, lower downfeed handle to advance bit to your mark.
3. With your other hand, advance lock nuts (A, Figure 8-1) on the depth stop rod until they are snug to the seat (B).
4. The drill bit will now advance to this point.
5. To release, advance nuts counterclockwise to top of depth stop.

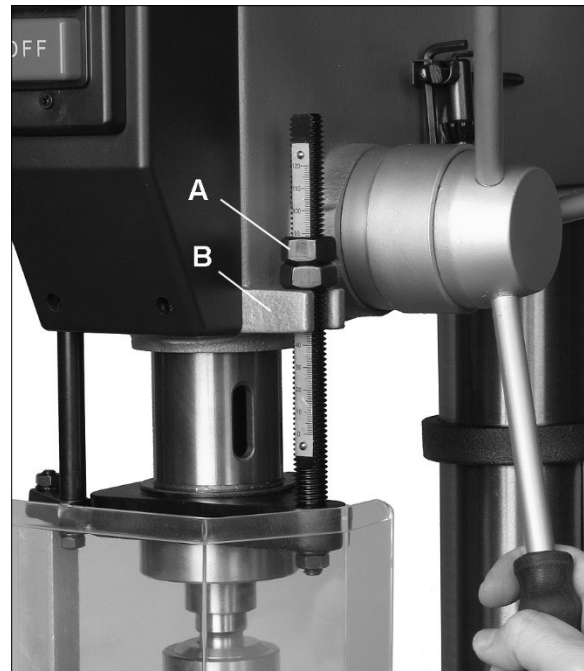

Figure 8-1: depth stop adjustment

8.2 Changing spindle speeds

A spindle speed and pulley/belt arrangement chart is affixed inside pulley cover, and also shown in sect. 12.0 of this manual.

To change spindle speeds:

1. Unplug machine from power source.
2. Loosen two thumb screws (C, Figure 8-2) found on each side of head assembly.
3. Rotate tension handle (D) clockwise to bring motor base as close to head as possible.
4. For desired speed, change location of belts per pulley/belt arrangement chart.
5. Rotate tension handle (D) counterclockwise to tension belts.
6. Tighten both thumb screws (C). Belts are properly tensioned when finger and thumb pressure midway between the two pulleys causes approximately 1/2-inch deflection.

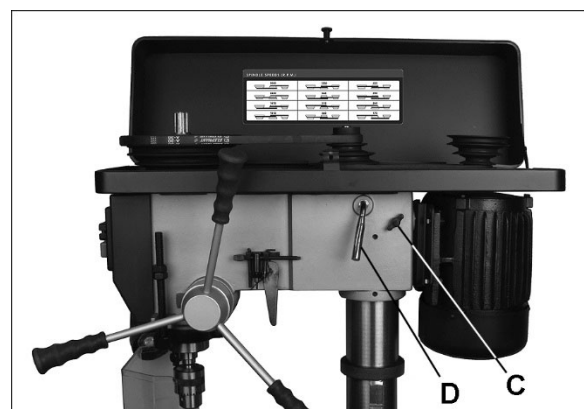

Figure 8-2: belt/speed adjustment

8.3 Return spring adjustment

The return spring is adjusted by the manufacturer and should not require attention. If adjustment is deemed necessary, follow the steps below while referring to Figure 8-3:

1. Unplug machine from power source.
2. Loosen lock nut (E). *Do not remove.*
3. Firmly hold coil spring cover (F).
4. Pull out cover and rotate until pin (G) on housing engages the next notch in coil spring cover. Turn cover clockwise to decrease tension and counterclockwise to increase tension.
5. Tighten lock nut (E). *Do not over-tighten or force nut too strongly against spring cover.*

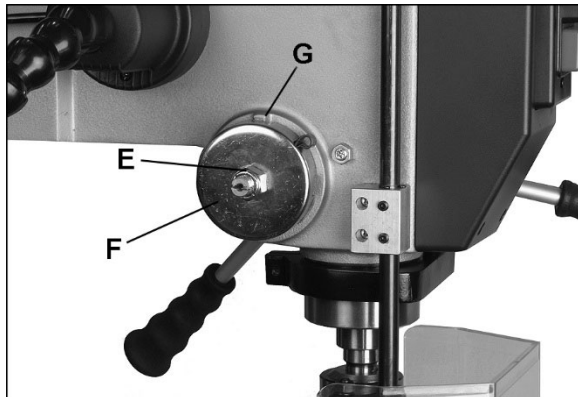

Figure 8-3: return spring adjustment

8.4 Table tilt adjustment

Table tilt adjustments are made on table bracket beneath table.

Refer to Figures 8-4 and 8-5.

CAUTION In the following steps do not over-loosen. This could cause table assembly to separate from column, fall and cause injury.

1. **IDP-17:** Loosen set screw (H) with 6mm hex wrench.
IDP-22: Loosen set screw (H) with 5mm hex wrench).
2. **IDP-17:** Loosen hex cap screw (J) with 23mm or adjustable wrench.
IDP-22: Loosen two hex nuts (J) with 19mm or adjustable wrench.
3. Tilt table to desired angle, referring to scale and pointer atop table bracket.
4. Tighten screw or nuts (J).
5. Tighten set screw (H).

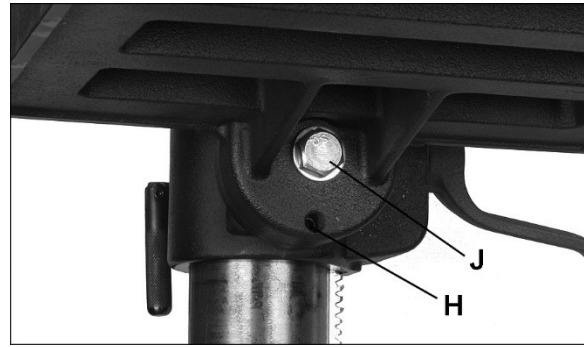

Figure 8-4: table tilt (IDP-17 only)

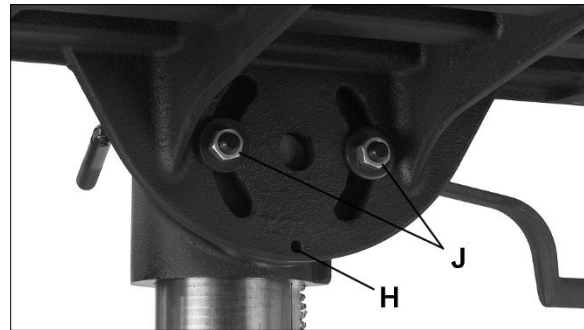

Figure 8-5: table tilt (IDP-22 only)

9.0 Operating controls

Press ON button to start spindle rotation. Press OFF to stop.

The work lamp operates independently; on/off button is on top of lamp housing.

10.0 Operation

1. Insert drill bit into chuck jaws about 1-inch (25.4mm) deep. When using a small bit, do not insert it so far that the jaws touch the flutes of the bit. Make sure bit is centered in chuck before tightening chuck with key.
 2. For a small workpiece that cannot be clamped to the table, use a drill press vise. The vise must be clamped or bolted to the table. Always use a back-up piece of scrap wood to cover the table. This protects both table and drill bit.
- WARNING** Workpiece must be clamped to table or secured in a drill press vise that is securely fastened to table. Failure to comply may cause serious injury.
3. Feed the bit into the material with only enough force to allow the drill bit to work. Feeding too slowly may cause burning of the workpiece. Feeding too quickly may cause the motor to stop and/or the drill bit to break.
 4. Generally speaking, the smaller the drill bit, the greater the RPM required. Soft materials require higher speeds; hard metals slower speeds.

11.0 User-maintenance

▲WARNING Before any intervention on the machine, disconnect it from electrical supply by pulling out plug or turning off main switch at electrical source. Failure to comply may cause serious injury.

A coat of automobile-type wax applied to table and column will help keep surfaces clean.

Check that bolts are tight and electrical cords are in good condition. If an electrical cord is worn, cut, or damaged in any way, have it replaced immediately.

In dusty environments, frequently blow out any dust that accumulates inside the motor fan cover.

Belts should be in good condition with no signs of cracks, frays or deterioration.

11.1 Lubrication

All ball bearings are pre-lubricated and sealed, and require no further lubrication.

Periodically apply #2 tube grease to:

- Rack.
- Table elevating mechanism, including worm gear.
- Splines (grooves) in spindle.
- Teeth of quill.

Periodically apply light coat of machine tool oil to quill and column.

The quill return spring should receive SAE 20 oil once yearly. Apply the oil beneath spring cover (F, Figure 8-3) using a squirt can.

11.2 Belt replacement

To loosen and remove the existing v-belts, use the same procedures described in *sect. 8.2, Changing spindle speeds*.

12.0 Spindle speed charts

12.1 Speed selection for IDP-17 Drill Press

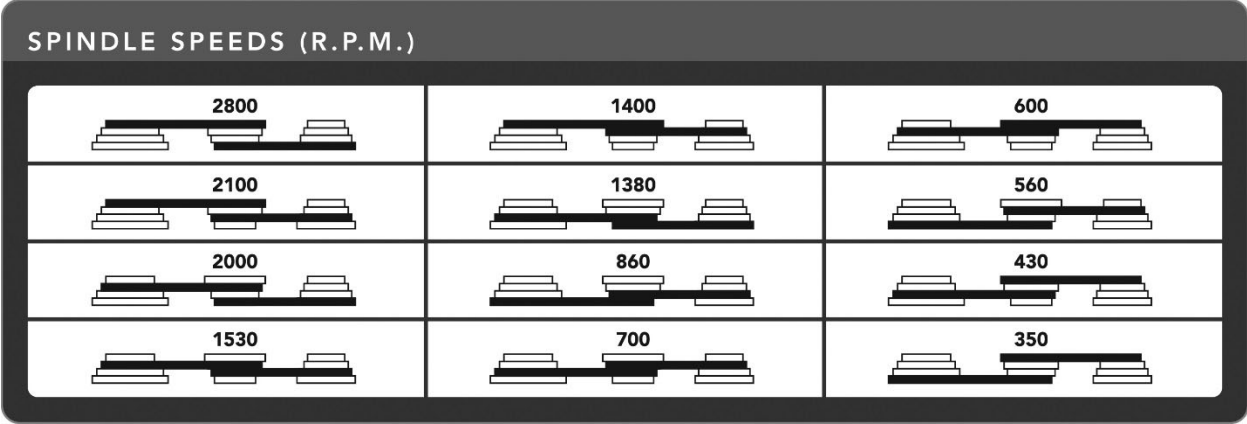

Figure 12-1: IDP-17 only

12.2 Speed selection for IDP-22 Drill Press

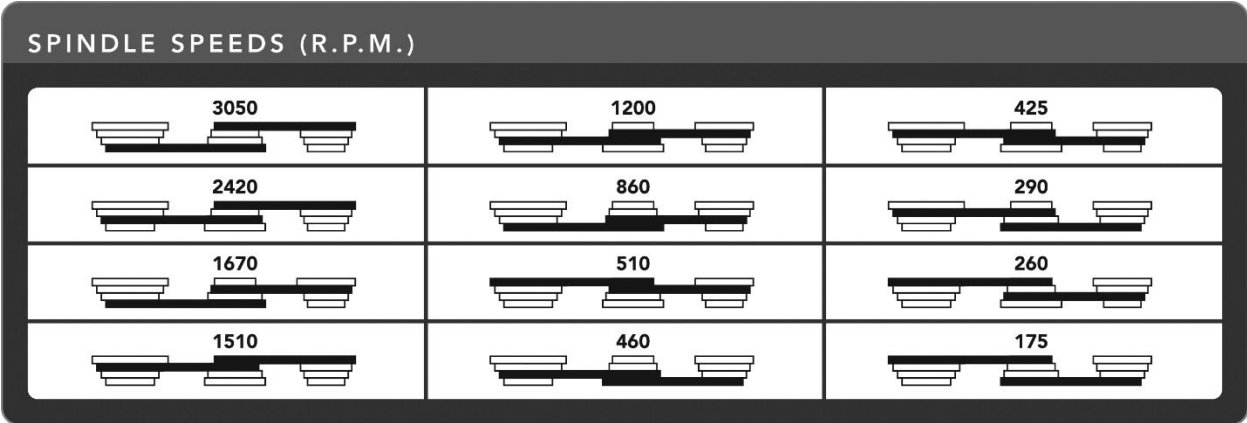

Figure 12-2: IDP-22 only

13.0 Troubleshooting IDP-17, IDP-22

| Symptom | Possible Cause | Correction * |
|--|--|---|
| Drill press will not start. | Drill press unplugged from wall, or motor. | Check all plug connections. |
| | Fuse blown, or circuit breaker tripped. | Replace fuse, or reset circuit breaker. |
| | Cord damaged. | Replace cord. |
| | Starting capacitor bad. | Replace starting capacitor. |
| Drill press does not come up to speed. | Extension cord too light or too long. | Replace with adequate size and length cord. |
| | Low current. | Contact a qualified electrician. |
| Drill Press vibrates excessively. | Base on uneven surface. | Locate drill press on even floor. |
| | Bad belt(s). | Replace belts. |
| Noisy operation. | Incorrect belt tension. | Adjust belt tension. |
| | Dry spindle. | Lubricate spindle. |
| | Loose spindle pulley. | Check tightness of retaining nut on pulley, and tighten if necessary. |
| | Loose motor pulley. | Tighten setscrews in pulleys. |
| Workpiece burns or smokes. | Incorrect Speed. | Change to appropriate speed. |
| | Chips not clearing from hole or bit. | Retract drill bit frequently to remove chips. |
| | Dull drill bit. | Resharpen, or replace drill bit. |
| | Feeding too slowly. | Increase feed rate. |
| Drill bit wanders. | Bit sharpened incorrectly. | Resharpen bit correctly. |
| | Bent drill bit. | Replace drill bit. |
| | Bit, or chuck not installed properly. | Reinstall the chuck, or bit properly. |
| Wood splinters on the underside. | No backing board used. | Place a scrap board underneath the workpiece to prevent splintering. |
| Drill bit binds in workpiece. | Workpiece pinching the bit. | Support or clamp workpiece. |
| | Excessive feed rate. | Decrease feed rate. |
| | Chuck jaws not tight. | Tighten chuck jaws. |
| | Improper belt tension. | Adjust belt tension. |
| Excessive drill bit runout, or wobble. | Bent drill bit. | Replace drill bit. |
| | Worn spindle bearings. | Replace spindle bearings. |
| | Bit, or chuck not properly installed. | Reinstall the bit, or chuck properly. |
| Quill returns too slow, or too fast. | Improper spring tension. | Adjust spring tension. |
| Chuck or arbor does not stay in place. | Dirt, grease, etc on arbor, chuck, or spindle. | Clean all mating surfaces thoroughly with a cleaner-degreaser. |

* **WARNING:** Some corrections may require a qualified electrician.

Table 2

14.0 Replacement Parts

Replacement parts are listed on the following pages. To order parts or reach our service department, call 1-800-274-6848 Monday through Friday, 8:00 a.m. to 5:00 p.m. CST. Having the Model Number and Serial Number of your machine available when you call will allow us to serve you quickly and accurately.

Some parts are shown for reference only, and may not be available individually.

Non-proprietary parts, such as fasteners, can usually be found at local hardware stores, or may be ordered from JET.

14.1.1 IDP-17 Drill Press – Exploded View

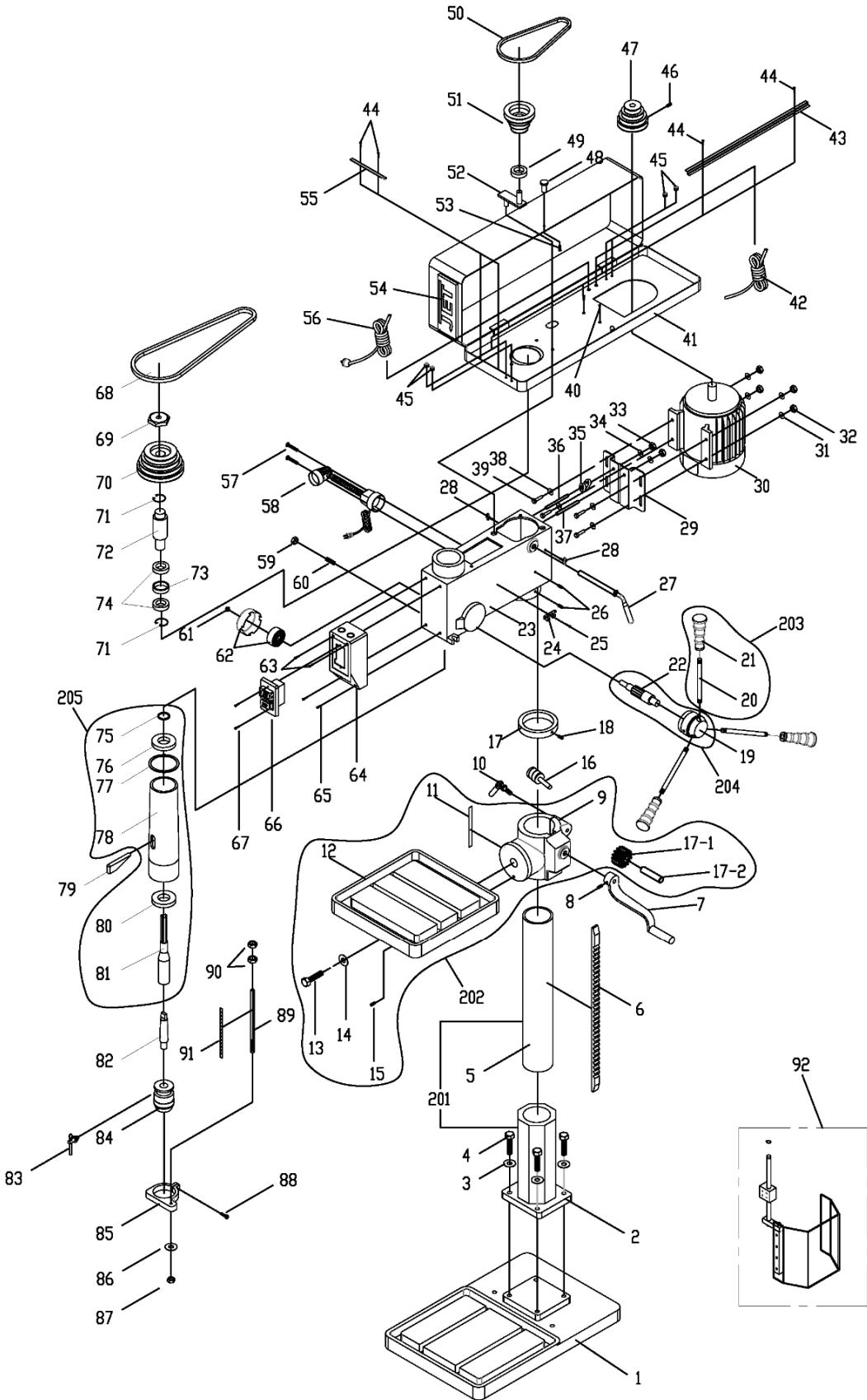

14.1.2 IDP-17 Drill Press – Parts List

| Index No | Part No | Description | Size | Qty |
|----------|--------------|---|-------------------|-----|
| 1 | IDP17-01 | Base | 550 x 350 x 53 mm | 1 |
| 201 | IDP17-201 | Column Assembly (#2, 5) | | 1 |
| 2 | IDP17-02 | Column Holder | | 1 |
| 3 | TS-0732061 | Spring Washer | 3/8" | 4 |
| 4 | TS-0209072 | Hex Cap Screw | 3/8" x 1-1/2" | 4 |
| 5 | IDP17-05 | Column | Ø80 mm | 1 |
| 6 | IDP17-06 | Rack | | 1 |
| 7 | IDP17-07 | Table Crank | | 1 |
| 8 | TS-0267021 | Set Screw | 1/4" x 1/4" | 1 |
| 202 | IDP17-202 | Table Assembly (#9, 11 thru 16, 17-1, 17-2) | | 1 |
| 9 | IDP17-09 | Table Bracket | | 1 |
| 10 | IDP17-10 | Clamp Bolt | 1/2" x 45 | 1 |
| 11 | IDP17-11 | Tilt Angle Scale | | 1 |
| 12 | IDP17-12 | Work Table | 358 x 358 x 44 | 1 |
| 13 | IDP17-13 | Screw | 5/8 x 1-3/4 | 1 |
| 14 | TS-0680081 | Flat Washer | 5/8" x 30 x 3 | 1 |
| 15 | TS-0271031 | Set Screw | 3/8" x 3/8" | 1 |
| 16 | IDP17-16 | Worm Gear Assembly | | 1 |
| 17 | IDP17-17 | Rack Collar | ID Ø80 mm | 1 |
| 17-1 | IDP17-17-1 | Pinion Gear | SC15 | 1 |
| 17-2 | IDP17-17-2 | Shaft | | 1 |
| 18 | TS-0267021 | Set Screw | 1/4" x 1/4" | 1 |
| 19 | IDP17-19 | Feed Hub | | 1 |
| 203 | IDP17-203 | Feed Handle Assembly (#20,21) | | 3 |
| 20 | IDP17-20 | Handle | | 3 |
| 21 | IDP17-21 | Knob | | 3 |
| 204 | IDP17-204 | Feed Pinion Assembly (#19,22) | | 1 |
| 22 | IDP17-22 | Feed Pinion | | 1 |
| 23 | IDP17-23 | Head Casting | | 1 |
| 24 | IDP17-24 | Chuck Key Fixture | | 1 |
| 25 | 5711571 | Phillips Pan Head Screw | 3/16" x 1/4" | 1 |
| 26 | TS-0271031 | Set Screw | 3/8" x 3/8" | 2 |
| 27 | IDP17-27 | Tension Adjust Handle | | 1 |
| 28 | IDP17-28 | Thumb Screw | 3/8" | 2 |
| 29 | IDP17-29 | Motor Mount Plate | | 1 |
| 30 | IDP17-30 | Motor | 1HP 1PH 115/230V | 1 |
| | IDP17-30-SC | Start Capacitor | 300MFD 125VAC | 1 |
| | IDP17-30-RC | Run Capacitor | 30µF 250VAC | 1 |
| | IDP17-30-MF | Motor Fan | | 1 |
| | IDP17-30-MFC | Motor Fan Cover | | 1 |
| | IDP17-30-JB | Junction Box | | 1 |
| | IDP17-30-JBC | Junction Box Cover | | 1 |
| 31 | TS-0680031 | Flat Washer | 5/16" | 4 |
| 32 | TS-0561021 | Hex Nut | 5/16" | 4 |
| 33 | TS-0561051 | Hex Nut | 1/2" | 2 |
| 34 | TS-0680061 | Flat Washer | 1/2" | 2 |
| 35 | IDP17-35 | Shaft Lever | | 1 |
| 36 | IDP17-36 | Adjusting Bolt B | | 1 |
| 37 | IDP17-37 | Adjusting Bolt A | | 1 |
| 38 | TS-0680031 | Flat Washer | 5/16" | 4 |
| 39 | TS-0051011 | Hex Cap Screw | 5/16" | 4 |
| 40 | IDP17-40 | Phillips Pan Washer Head Screw | 1/4" x 3/8" | 4 |
| 41 | IDP17-41 | Pulley Cover | | 1 |
| 42 | IDP17-42 | Motor Cord | | 1 |
| 43 | IDP17-43 | Hold Down Strip | | 2 |
| 44 | 5711571 | Phillips Pan Head Screw | 3/16" x 1/4" | 3 |
| 45 | IDP17-45 | Strain Relief | | 4 |
| 46 | TS-1523011 | Set Screw | M6 x 8 mm | 1 |
| 47 | IDP17-47 | Motor Pulley | | 1 |
| 48 | IDP17-48 | Knob | | 1 |

| Index No | Part No | Description | Size | Qty |
|----------|------------|---------------------------------|---------------|-----|
| 49 | BB-6202 | Ball Bearing | 6202 | 1 |
| 50 | VB-A26 | V-Belt | A26 | 1 |
| 51 | IDP17-51 | Center Pulley | | 1 |
| 52 | IDP17-52 | Pivot Bracket | | 1 |
| 53 | TS-081F031 | Head Flat Screw | 1/4" x 1/2" | 1 |
| 54 | JET-138 | JET Logo with adhesive | 138 x 57 mm | 1 |
| 55 | IDP17-55 | Hold Down Strip | | 1 |
| 56 | IDP17-56 | Power Cord | 3x18AWG, 300V | 1 |
| 57 | IDP17-57 | Screw | 3/16" x 45 mm | 2 |
| 58 | IDP17-58 | Work Lamp | | 1 |
| 59 | TS-0561021 | Hex Nut | 5/16" | 1 |
| 60 | TS-0270101 | Set Screw | 5/16" x 30 mm | 1 |
| 61 | TS-0561051 | Nylon Lock Hex Nut | 1/2" | 1 |
| 62 | IDP17-62 | Coil Spring with Cover | | 1 |
| 63 | IDP17-63 | Phillips Screw | 3/16" x 70 | 2 |
| 64 | IDP17-64 | Switch Box | | 1 |
| 65 | IDP17-65 | Phillips Pan Head Screw | 3/16" x 45 | 2 |
| 66 | IDP17-66 | On-Off Switch | | 1 |
| 67 | IDP17-67 | Flat Head Screw | 1" x 4 mm | 2 |
| 68 | VB-A27 | V-Belt | A27 | 1 |
| 69 | TS-0561071 | Hex Nut | 5/8" | 1 |
| 70 | IDP17-70 | Spindle Pulley | | 1 |
| 71 | IDP17-71 | Retaining Ring | Ø56 mm | 2 |
| 72 | IDP17-72 | Drive Taper | | 1 |
| 73 | IDP17-73 | Ball Spacer | | 1 |
| 74 | BB-6205 | Ball Bearing | 6205 | 2 |
| 75 | F006042 | External Retaining Ring | Ø14 mm | 1 |
| 76 | BB-6202 | Ball Bearing | 6202 | 1 |
| 77 | IDP17-77 | Rubber Washer | | 1 |
| 205 | IDP17-205 | Quill Assembly (#75-78, 80,81) | | 1 |
| 78 | IDP17-78 | Quill | | 1 |
| 79 | IDP17-79 | Drift Key | | 1 |
| 80 | BB-6205 | Ball Bearing | 6205 | 1 |
| 81 | IDP17-81 | Spindle | MT2 | 1 |
| 82 | 561766 | Morse Taper Arbor | MT2-JT3 | 1 |
| 83 | 561708-CK | Chuck Key | | 1 |
| 84 | 561708 | Chuck and Key | JT3, 5/8" | 1 |
| 85 | IDP17-85 | Depth Stop Base | | 1 |
| 86 | TS-0680041 | Flat Washer | 3/8" | 1 |
| 87 | TS-0561031 | Hex Nut | 3/8" | 1 |
| 88 | TS-0050031 | Hex Cap Screw | 1/4" x 3/4" | 1 |
| 89 | IDP17-89 | Scale Bolt | | 1 |
| 90 | TS-0561071 | Hex Nut | 5/8" | 2 |
| 91 | IDP17-91 | Scale (mm) | | 1 |
| 92 | IDP17-92 | Spindle Guard Assembly | | 1 |
| 93 | LM000146 | Warning Label (not shown) | | 1 |
| 94 | LM000147 | ID Label, IDP-17 (not shown) | | 1 |
| 95 | LM000149 | Spindle Speed Chart (not shown) | | 1 |
| 96 | LM000151 | Motor Label (not shown) | | 1 |

14.2.1 IDP-22 Drill Press – Exploded View

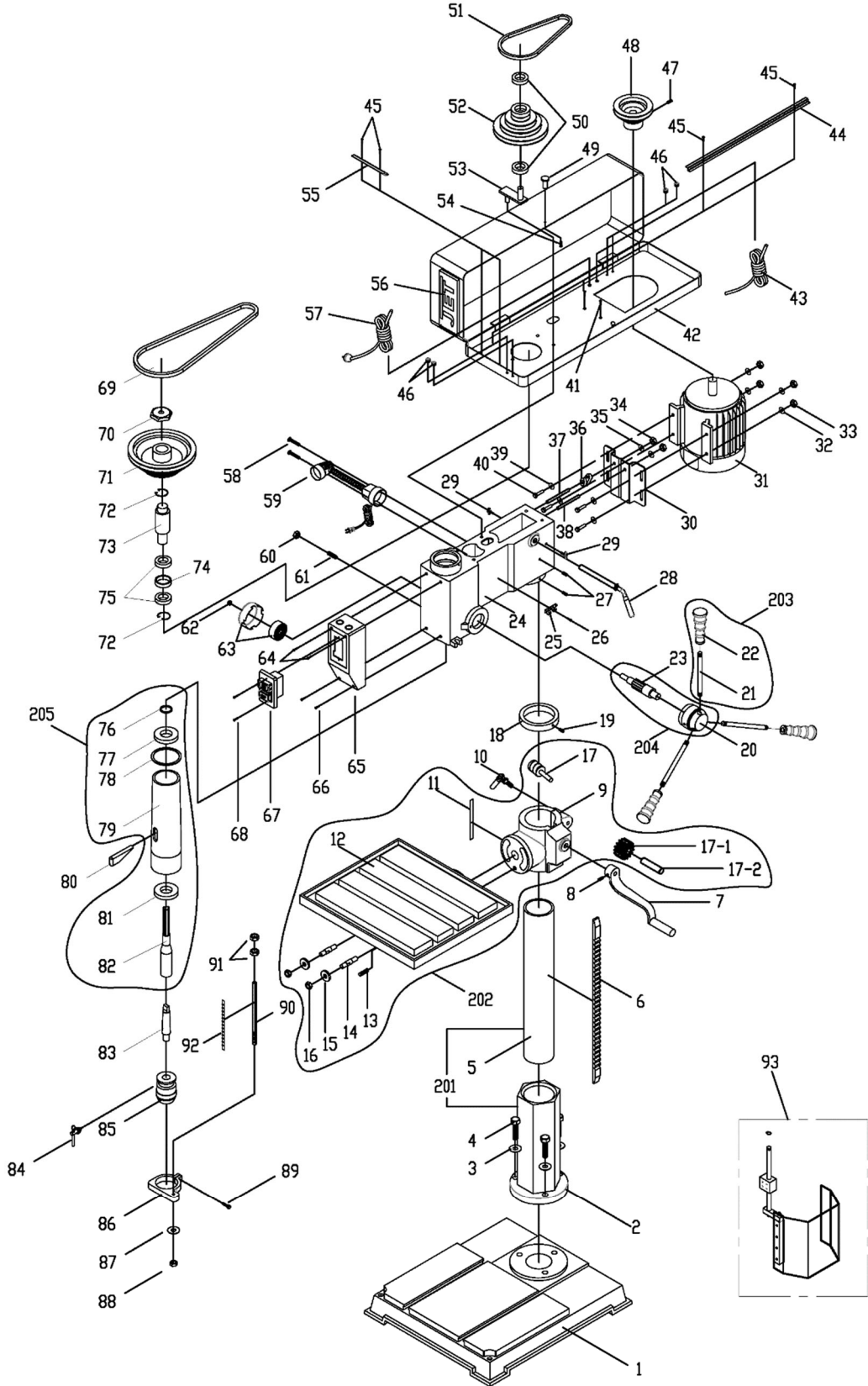

14.2.2 IDP-22 Drill Press – Parts List

| Index No | Part No | Description | Size | Qty |
|----------|--------------|--------------------------------|---------------------|-----|
| 1 | IDP22-01 | Base | 575 x 500 x 85 | 1 |
| 201 | IDP22-201 | Column Assembly (#2,5) | | 1 |
| 2 | IDP22-02 | Column Holder | | 1 |
| 3 | TS-0720111 | Spring Washer | 1/2" | 3 |
| 4 | TS-0070051 | Hex Cap Screw | 1/2" x 2 mm | 3 |
| 5 | IDP22-05 | Column | Ø92 | 1 |
| 6 | IDP22-06 | Rack | | 1 |
| 7 | IDP22-07 | Table Crank | | 1 |
| 8 | TS-0267022 | Set Screw | 1/4" x 1/4" | 1 |
| 202 | IDP22-202 | Table Assembly (#9, 11-16) | | 1 |
| 9 | IDP22-09 | Table Bracket | | 1 |
| 10 | IDP22-10 | Clamp Bolt | 1/2" x 70 mm | 1 |
| 11 | IDP22-11 | Tilt Angle Scale | | 1 |
| 12 | IDP22-12 | Work Table | 475 x 413 x 41 | 1 |
| 13 | TS-0271031 | Set Screw | 3/8" x 3/8" | 1 |
| 14 | IDP22-14 | Screw | 9/16" x 1/2" x 62 | 2 |
| 15 | TS-0680061 | Flat Washer | 1/2" x 34 x 5 mm | 2 |
| 16 | TS-0561051 | Hex Nut | 1/2" | 2 |
| 17 | IDP22-17 | Worm Gear Assembly | | 1 |
| 17-1 | IDP22-17-1 | Pinion Gear | SC15 | 1 |
| 17-2 | IDP22-17-2 | Shaft | | 1 |
| 18 | IDP22-18 | Rack Collar | Ø92 | 1 |
| 19 | TS-0267021 | Set Screw | 1/4" x 1/4" | 1 |
| 20 | IDP22-20 | Feed Hub | | 1 |
| 203 | IDP17-203 | Feed Handle Assembly (#21,22) | | 3 |
| 21 | IDP22-21 | Handle | | 3 |
| 22 | IDP22-22 | Knob | | 3 |
| 204 | IDP22-204 | Feed Pinion Assembly (#20,23) | | 1 |
| 23 | IDP22-23 | Feed Pinion | | 1 |
| 24 | IDP22-24 | Head Casting | | 1 |
| 25 | IDP22-25 | Chuck Key Fixture | | 1 |
| 26 | 5711571 | Phillips Pan Head Screw | 3/16" x 1/4" | 1 |
| 27 | TS-0271031 | Set Screw | 3/8" x 3/8" | 2 |
| 28 | IDP22-27 | Tension Adjust Handle | | 1 |
| 29 | IDP22-29 | Thumb Screw | 3/8" x 32 | 2 |
| 30 | IDP22-30 | Mounting Plate | | 1 |
| 31 | IDP22-31 | Motor | 1-1/2HP 115/230V | 1 |
| | IDP22-31MF | Motor Fan | | 1 |
| | IDP22-31MFC | Motor Fan Cover (not shown) | | 1 |
| | IDP22-31SC | Start Capacitor | 400MFD 125VAC | 1 |
| | IDP22-31RC | Run Capacitor | 40µF 250VAC | 1 |
| | IDP17-30-JB | Junction Box | | 1 |
| | IDP17-30-JBC | Junction Box Cover | | 1 |
| 32 | TS-0680031 | Flat Washer | 5/16" x 18 x 1.5 mm | 4 |
| 33 | TS-0561021 | Hex Nut | 5/16" | 4 |
| 34 | TS-0561051 | Hex Nut | 1/2" | 2 |
| 35 | TS-0680061 | Flat Washer | 1/2" | 2 |
| 36 | IDP22-36 | Shaft Lever | | 1 |
| 37 | IDP22-37 | Adjusting Bolt B | | 1 |
| 38 | IDP22-38 | Adjusting Bolt A | | 1 |
| 39 | TS-0680031 | Flat Washer | 5/16" x 18 x 1.5 mm | 4 |
| 40 | TS-0051011 | Hex Cap Screw | 5/16" | 4 |
| 41 | TS-0207011 | Phillips Pan Washer Head Screw | 1/4" x 3/8" | 4 |
| 42 | IDP22-42 | Pulley Cover | | 1 |
| 43 | IDP22-43 | Motor Cord | 3x14AWG, 300V | 1 |
| 44 | IDP22-44 | Hold Down Strip | | 1 |
| 45 | 5711571 | Phillips Pan Head Screw | 3/16" x 1/4" | 3 |
| 46 | IDP22-46 | Strain Relief | | 1 |
| 47 | TS-1523011 | Set Screw | M6 x 8 | 1 |
| 48 | IDP22-48 | Motor Pulley | | 1 |

| Index No | Part No | Description | Size | Qty |
|----------|------------|---------------------------------|----------------|-----|
| 49 | IDP22-49 | Knob | | 1 |
| 50 | BB-6202 | Ball Bearing | 6202 | 2 |
| 51 | VB-A27 | V-Belt | A27 | 1 |
| 52 | IDP22-52 | Center Pulley | | 1 |
| 53 | IDP22-53 | Pivot Bracket | | 1 |
| 54 | TS-081F031 | Socket Head Flat Screw | 1/4" x 1/2" | 1 |
| 55 | IDP22-55 | Hold Down Strip | | 1 |
| 56 | JET-138 | JET Logo with adhesive | 138 x 57 mm | 1 |
| 57 | IDP22-57 | Power Cord | 3x14AWG, 300V | 1 |
| 58 | IDP22-58 | Screw | | 1 |
| 59 | IDP22-59 | Work Lamp | | 1 |
| 60 | TS-0561021 | Hex Nut | 5/16" | 1 |
| 61 | TS-0270091 | Set Screw | 5/16" x 1" | 1 |
| 62 | TS-0561051 | Hex Nylon Lock Nut | 1/2" | 1 |
| 63 | IDP22-63 | Coil Spring with Cover | | 1 |
| 64 | IDP22-64 | Phillips Screw | 3/16" x 70 mm | 2 |
| 65 | IDP22-65 | Switch Box | | 1 |
| 66 | IDP22-66 | Phillips Pan Head Screw | 3/16" x 1-1/2" | 2 |
| 67 | IDP17-66 | On-Off Switch | | 1 |
| 68 | IDP22-68 | Flat Head Screw | 1" x 4 mm | 2 |
| 69 | VB-A38 | V-Belt | A38 | 1 |
| 70 | IDP22-70 | Nut | | 1 |
| 71 | IDP22-71 | Spindle Pulley | | 1 |
| 72 | F006058 | External Retaining Ring | Ø65 mm | 2 |
| 73 | IDP22-73 | Drive Taper | | 1 |
| 74 | IDP22-74 | Ball Spacer | | 1 |
| 75 | BB-6007 | Ball Bearing | 6007 | 2 |
| 76 | IDP22-76 | Retaining Ring | | 1 |
| 77 | BB-6005 | Ball Bearing | 6005 | 1 |
| 78 | IDP22-78 | Rubber Washer | | 1 |
| 205 | IDP22-205 | Quill Assembly (#76-79, 81,82) | | 1 |
| 79 | IDP22-79 | Quill | | 1 |
| 80 | IDP22-80 | Drift Key | | 1 |
| 81 | BB-6206 | Ball Bearing | 6206 | 1 |
| 82 | IDP22-82 | Spindle | MT3 | 1 |
| 83 | 561763 | Morse Taper Arbor | MT3 x JT3 | 1 |
| 84 | 561708-CK | Chuck Key | | 1 |
| 85 | 561708 | Chuck and Key | JT3, 5/8" | 1 |
| 86 | IDP22-86 | Depth Stop Base | | 1 |
| 87 | TS-0680041 | Flat Washer | 3/8" | 1 |
| 88 | TS-0561031 | Hex Nut | 3/8" | 1 |
| 89 | TS-0050031 | Hex Cap Screw | 1/4" x 3/4" | 1 |
| 90 | IDP22-90 | Depth Stop Rod | | 1 |
| 91 | TS-0561071 | Hex Nut | 5/8" | 2 |
| 92 | IDP22-92 | Scale (mm) | | 1 |
| 93 | IDP17-92 | Spindle Guard Assembly | | 1 |
| 94 | LM000146 | Warning Label (not shown) | | 1 |
| 95 | LM000148 | ID Label, IDP-22 (not shown) | | 1 |
| 96 | LM000150 | Spindle Speed Chart (not shown) | | 1 |
| 97 | LM000152 | Motor Label (not shown) | | 1 |

15.0 Electrical Connections for IDP-17, IDP-22

115/230V

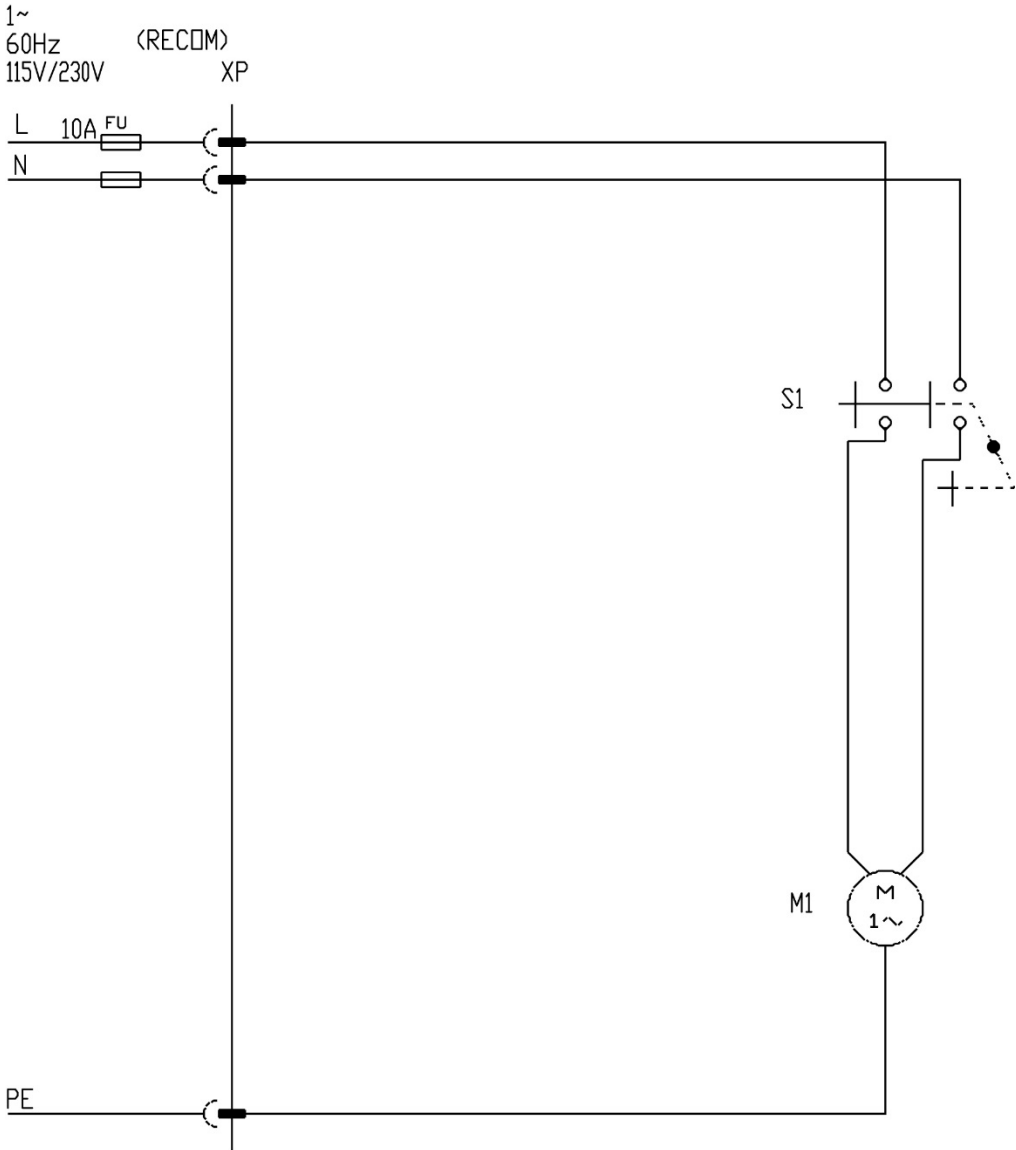

16.0 Warranty and service

JET warrants every product it sells against manufacturers' defects. If one of our tools needs service or repair, please contact Technical Service by calling 1-800-274-6846, 8AM to 5PM CST, Monday through Friday.

Warranty Period

The general warranty lasts for the time period specified in the literature included with your product or on the official JET branded website.

- JET products carry a limited warranty which varies in duration based upon the product. (See chart below)
- Accessories carry a limited warranty of one year from the date of receipt.
- Consumable items are defined as expendable parts or accessories expected to become inoperable within a reasonable amount of use and are covered by a 90 day limited warranty against manufacturer's defects.

Who is Covered

This warranty covers only the initial purchaser of the product from the date of delivery.

What is Covered

This warranty covers any defects in workmanship or materials subject to the limitations stated below. This warranty does not cover failures due directly or indirectly to misuse, abuse, negligence or accidents, normal wear-and-tear, improper repair, alterations or lack of maintenance. JET woodworking machinery is designed to be used with Wood. Use of these machines in the processing of metal, plastics, or other materials outside recommended guidelines may void the warranty. The exceptions are acrylics and other natural items that are made specifically for wood turning.

Warranty Limitations

Woodworking products with a Five Year Warranty that are used for commercial or industrial purposes default to a Two Year Warranty. Please contact Technical Service at 1-800-274-6846 for further clarification.

How to Get Technical Support

Please contact Technical Service by calling 1-800-274-6846. **Please note that you will be asked to provide proof of initial purchase when calling.** If a product requires further inspection, the Technical Service representative will explain and assist with any additional action needed. JET has Authorized Service Centers located throughout the United States. For the name of an Authorized Service Center in your area call 1-800-274-6846 or use the Service Center Locator on the JET website.

More Information

JET is constantly adding new products. For complete, up-to-date product information, check with your local distributor or visit the JET website.

How State Law Applies

This warranty gives you specific legal rights, subject to applicable state law.

Limitations on This Warranty

JET LIMITS ALL IMPLIED WARRANTIES TO THE PERIOD OF THE LIMITED WARRANTY FOR EACH PRODUCT. EXCEPT AS STATED HEREIN, ANY IMPLIED WARRANTIES OF MERCHANTABILITY AND FITNESS FOR A PARTICULAR PURPOSE ARE EXCLUDED. SOME STATES DO NOT ALLOW LIMITATIONS ON HOW LONG AN IMPLIED WARRANTY LASTS, SO THE ABOVE LIMITATION MAY NOT APPLY TO YOU.

JET SHALL IN NO EVENT BE LIABLE FOR DEATH, INJURIES TO PERSONS OR PROPERTY, OR FOR INCIDENTAL, CONTINGENT, SPECIAL, OR CONSEQUENTIAL DAMAGES ARISING FROM THE USE OF OUR PRODUCTS. SOME STATES DO NOT ALLOW THE EXCLUSION OR LIMITATION OF INCIDENTAL OR CONSEQUENTIAL DAMAGES, SO THE ABOVE LIMITATION OR EXCLUSION MAY NOT APPLY TO YOU.

JET sells through distributors only. The specifications listed in JET printed materials and on official JET website are given as general information and are not binding. JET reserves the right to effect at any time, without prior notice, those alterations to parts, fittings, and accessory equipment which they may deem necessary for any reason whatsoever. JET® branded products are not sold in Canada by JPW Industries, Inc.

Product Listing with Warranty Period

| |
|--|
| 90 Days – Parts; Consumable items |
| 1 Year – Motors; Machine Accessories |
| 2 Year – Metalworking Machinery; Electric Hoists, Electric Hoist Accessories; Woodworking Machinery used for industrial or commercial purposes |
| 5 Year – Woodworking Machinery |
| Limited Lifetime – JET Parallel clamps; VOLT Series Electric Hoists; Manual Hoists; Manual Hoist Accessories; Shop Tools; Warehouse & Dock products; Hand Tools; Air Tools |

NOTE: JET is a division of JPW Industries, Inc. References in this document to JET also apply to JPW Industries, Inc., or any of its successors in interest to the JET brand.

This page intentionally left blank.



427 New Sanford Road
LaVergne, Tennessee 37086
Phone: 800-274-6848
www.jettools.com