



Operating Instructions and Parts Manual

Sliding Dual-Bevel Compound Miter Saw

Model JMS-10X and JMS-12X



JET
427 New Sanford Road
LaVergne, Tennessee 37086
Ph.: 800-274-6848
www.jettools.com

Part No. M-707210
Edition 1 06/2019
Copyright © 2019 JET



1.0 IMPORTANT SAFETY INSTRUCTIONS

WARNING – To reduce risk of injury:

1.1 General machine safety warnings

1. Read and understand the entire owner's manual before attempting assembly or operation.
2. Read and understand the warnings posted on the machine and in this manual. Failure to comply with all of these warnings may cause serious injury.
3. Replace warning labels if they become obscured or removed.
4. This saw is designed and intended for use by properly trained and experienced personnel only. If you are not familiar with the proper and safe operation of a miter saw, do not use until proper training and knowledge have been obtained.
5. Do not use this saw for other than its intended use. If used for other purposes, JET disclaims any real or implied warranty and holds itself harmless from any injury that may result from that use.
6. Always wear approved safety glasses or face shield while using this saw. Everyday eyeglasses only have impact resistant lenses; they are not safety glasses.
7. Before operating this saw, remove tie, rings, watches and other jewelry, and roll sleeves up past the elbows. Do not wear loose clothing. Confine long hair. Non-slip footwear or anti-skid floor strips are recommended. Do not wear gloves.
8. Wear ear protectors (plugs or muffs) during extended periods of operation.
9. Make certain the switch is in the OFF position before connecting the machine to the power supply.
10. Make certain the machine is properly grounded.
11. Make all machine adjustments or maintenance with the machine unplugged from the power source.
12. Remove adjusting keys and wrenches. Form a habit of checking to see that keys and adjusting wrenches are removed from the machine before turning it on.
13. Keep safety guards in place at all times when the machine is in use. If removed for maintenance purposes, use extreme caution and replace the guards immediately after completion of maintenance.
14. Check damaged parts. Before further use of the machine, a guard or other part that is damaged should be carefully checked to determine that it will operate properly and perform its intended function. Check for alignment of moving parts, binding of moving parts, breakage of parts, mounting and any other conditions that may affect its operation. A guard or other part that is damaged should be properly repaired or replaced.
15. Provide for adequate space surrounding work area and non-glare, overhead lighting.
16. Keep the floor around the machine clean and free of scrap material, oil and grease.
17. Keep visitors a safe distance from the work area. Keep children away.
18. Make your workshop child proof with padlocks or master switches.
19. Give your work undivided attention. Looking around, carrying on a conversation and "horse-play" are careless acts that can result in serious injury.
20. Maintain a balanced stance at all times so that you do not fall into the blade or other moving parts. Do not overreach or use excessive force to perform any machine operation.
21. Use the right tool at the correct speed and feed rate. Do not force a tool or attachment to do a job for which it was not designed. The right tool will do the job better and more safely.
22. Use recommended accessories; improper accessories may be hazardous.
23. Maintain tools with care. Keep saw blades sharp and clean for the best and safest performance. Follow instructions for lubricating and changing accessories.
24. Always disconnect power to the machine (unplug) before performing maintenance.
25. Use a brush or compressed air to remove chips or debris — do not use bare hands.
26. Do not stand on the machine. Serious injury could occur if the machine tips over.
27. Never leave the machine running unattended. Turn the power off and do not leave the machine until it comes to a complete stop.
28. Remove loose items and unnecessary work pieces from the area before starting the machine.

29. Keep hands out of the line of saw blade.
30. Don't use in dangerous environment. Don't use power tools in damp or wet location, or expose them to rain. Keep work area well lighted.

1.2 Miter saw safety warnings

Specific safety instructions for this compound miter saw:

31. Do not operate the miter saw until it is completely assembled and installed according to these instructions.
32. If you are not familiar with the operation of miter saws, seek guidance from your supervisor, instructor or other qualified person.
33. Always hold the work firmly against the fence and table.
34. Do not perform free-hand operations; use clamp wherever possible.
35. Keep hands out of the path of the saw blade. If the workpiece you are cutting would cause your hands to be within 8 inches of the saw blade, the workpiece should be clamped in place before making the cut.
36. Be sure the blade is sharp, runs freely and is free of vibration.
37. Allow the motor to come up to full speed before starting a cut.
38. Keep the motor air vents clean and free of chips or dust.
39. Make sure all handles are tight before cutting, even if table is positioned in one of the positive stops.
40. Be sure both the blade and the flange are clean and the arbor bolt is tightened securely.
41. Use only blade flanges specified for your saw.
42. Never use blades larger in diameter than the size specified by your particular model.
43. Never apply lubricants to the blade when it is running.
44. Always check the blade for cracks or damage before operation. Replace a cracked or damaged blade immediately.
45. Never use blades rated for fewer RPM's than the rated speed of the saw. See your saw specifications.
46. Always keep blade guards in place and use at all times.
47. Never reach around the saw blade.
48. Make sure the blade is not contacting the workpiece before the switch is turned ON.
49. After completing the cut, release the trigger and wait for the blade to stop before returning the saw to raised position.
50. Make sure the blade has come to a complete stop before removing or securing the workpiece, changing the workpiece angle or changing the angle of the blade.
51. Never cut metals or masonry products with this tool. This miter saw is designed for use on wood and wood-like products.
52. Never cut small pieces. If the workpiece being cut would cause your hand or fingers to be within 8 inches of the saw blade, the workpiece is too small.
53. Provide adequate support to the sides of the saw table for long work pieces.
54. Never use the miter saw in an area with flammable liquids or gases.
55. Never use solvents to clean plastic parts. Solvents could possibly dissolve or otherwise damage the material.
56. Shut off the power before servicing or adjusting the tool.
57. Disconnect the saw from the power source and clean the machine when finished using.
58. Make sure the work area is clean before leaving the machine.
59. Should any part of your miter saw be missing, damaged, or fail in any way, or any electrical component fail to perform properly, remove the plug from the power supply outlet. Replace missing, damaged, or failed parts before resuming operation.

 **WARNING:** This product can expose you to chemicals including lead and cadmium which are known to the State of California to cause cancer and birth defects or other reproductive harm, and phthalates which are known to the State of California to cause birth defects or other reproductive harm. For more information go to <http://www.p65warnings.ca.gov>.

 **WARNING:** Drilling, sawing, sanding or machining wood products generates wood dust and other substances known to the State of California to cause cancer. Avoid inhaling dust generated from wood products or use a dust mask or other safeguards for personal protection.

Wood products emit chemicals known to the State of California to cause birth defects or other reproductive harm. For more information go to <http://www.p65warnings.ca.gov/wood>.

Familiarize yourself with the following safety notices used in this manual:



This means that if precautions are not heeded, it may result in minor injury and/or possible machine damage.



This means that if precautions are not heeded, it may result in serious, or possibly even fatal, injury.

2.0 Table of contents

Section	Page
1.0 IMPORTANT SAFETY INSTRUCTIONS	2
1.1 General machine safety warnings	2
1.2 Miter saw safety warnings	3
2.0 Table of contents	4
3.0 About this manual	6
4.0 Features and terminology	7
5.0 Specifications	8
5.1 Cutting capacities	9
6.0 Setup and assembly	10
6.1 Unpacking	10
6.2 Shipping contents	10
6.3 Tools required for assembly	10
6.4 Transporting the saw	10
6.5 Mounting saw to bench	10
6.6 Releasing slide carriage	10
6.7 Releasing cutting head	10
6.8 Dust extraction	10
6.9 Power cord storage clips	11
6.10 Saw blade wrench	11
6.11 Installing hold-down	11
6.12 Removing/installing blade	11
7.0 Electrical connections	12
7.1 Extension cords	12
8.0 Adjustments	13
8.1 Support foot	13
8.2 Miter angle setting	13
8.3 Table extensions and work stop	13
8.4 Fence adjustment	14
8.5 Bevel adjustments	14
8.6 Depth adjustment	15
9.0 Operation	15
9.1 LED light	15
9.2 Laser guide	15
9.3 General saw operation	16
9.4 Jammed material	16
9.5 Cutting options	16
9.6 Cutting bowed material	17
9.7 Rough cutting a dado	17
9.8 Base molding	17
9.9 Crown molding	17
10.0 User-maintenance	17
10.1 General cleaning	17
10.2 Lower Blade Guard	18
10.3 Lubrication	18
10.4 Commutator brush inspection	18
10.5 Additional servicing	18
11.0 Crown molding charts	19

11.1 Crown molding: 90° wall angles	19
11.2 Crown molding: various wall angles	20
12.0 Troubleshooting JMS-10X,12X Miter Saws	21
13.0 Replacement Parts.....	22
13.1.1 JMS-10X (#707210) – Miter Saw Assembly – Exploded View I.....	23
13.1.2 JMS-10X (#707210) – Miter Saw Assembly – Exploded View II.....	24
13.1.3 JMS-10X (#707210) – Miter Saw Assembly – Parts List.....	25
13.2.1 JMS-12X (#707212) – Miter Saw Assembly – Exploded View I.....	29
13.2.2 JMS-12X (#707212) – Miter Saw Assembly – Exploded View II.....	30
13.2.3 JMS-12X (#707212) – Miter Saw Assembly – Parts List.....	31
14.0 Electrical Connections – JMS-10X,12X	35
15.0 Warranty and service	36

3.0 About this manual

This manual is provided by JET, covering the safe operation and maintenance procedures for a JET Model JMS-10X and JMS-12X Miter Saw. This manual contains instructions on installation, safety precautions, general operating procedures, maintenance instructions and parts breakdown. Your machine has been designed and constructed to provide consistent, long-term operation if used in accordance with the instructions set forth in this document.

If there are questions or comments, please contact your local supplier or JET. JET can also be reached at our web site: www.jettools.com.

Retain this manual for future reference. If the machine transfers ownership, the manual should accompany it.

 WARNING Read and understand the entire contents of this manual before attempting assembly or operation. Failure to comply may cause serious injury.

Register your product using the provided mail-in card, or register online: <http://www.jettools.com/us/en/service-and-support/warranty/registration/>

4.0 Features and terminology

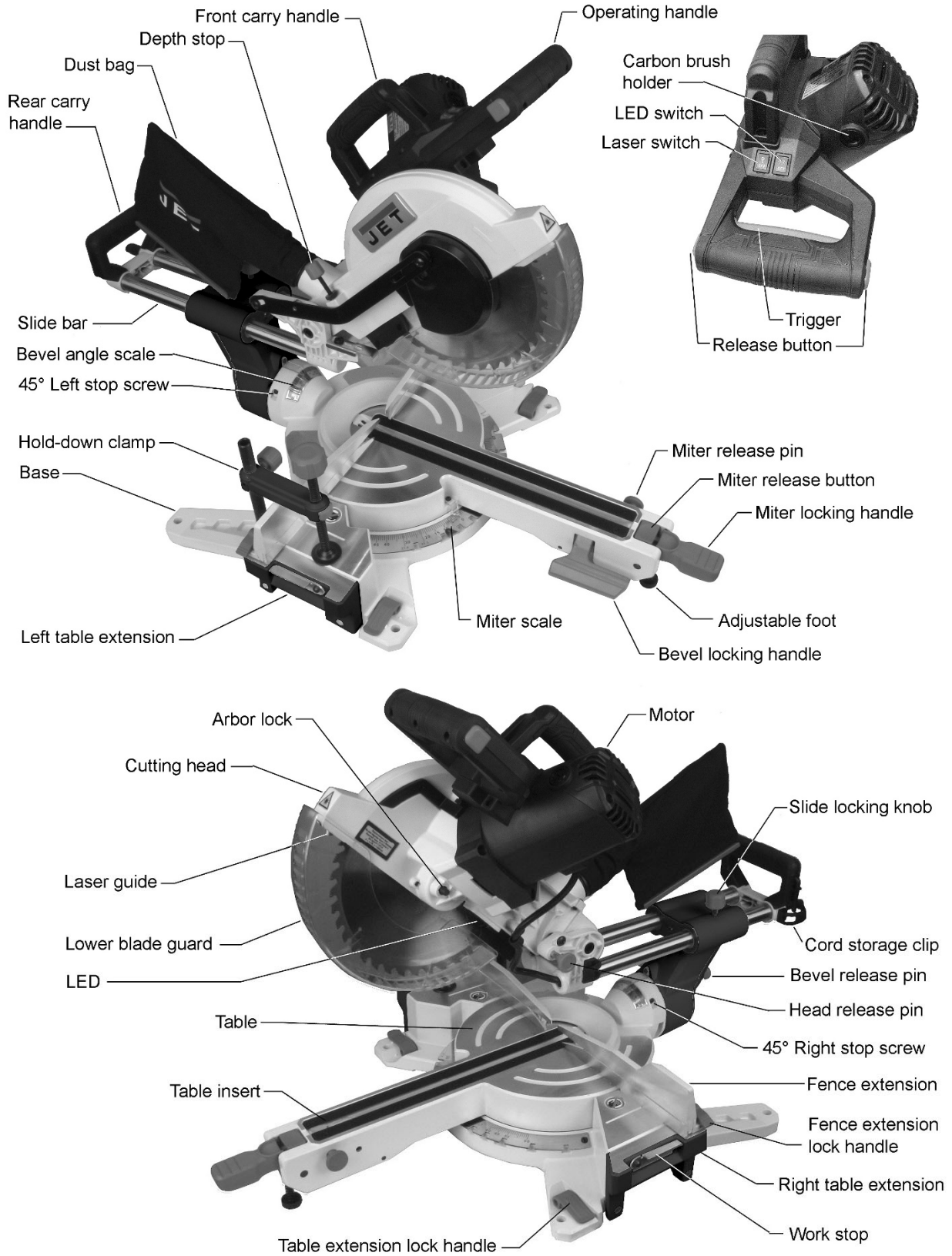

Figure 4-1: Features and Terminology

5.0 Specifications

Table 1

Model number	JMS-10X	JMS-12X
Stock number	707210	707212
Motor and Electricals		
Motor type	Series-wound, double insulated	
Input power	1.7 kW	
Phase	single	
Voltage	115 V	
Cycle	60 Hz	
Listed FLA (full load amps)	15 A	
Motor speed	4000±10% RPM	
Starting amps	25 A	
Running amps (no load)	5.10 A	5.33±10% A
Switch	Saw: 18A,127V; Laser: 6A 250AC; LED: 10A 125VAC	
Power cable	SJT 14AWGx3C, 8-1/2 ft.	
Power plug	Type ZT-1 (115V), without ground	
Recommended circuit size ¹	15 A	
Sound emission ²	95 dB at 3 ft. (900mm) from blade	
Laser	Class 2, 3V 400~700 NM	
Work light	LED	
Capacities and measurements		
Blade speed	4000±10% RPM	
Motor arbor size	Ø 5/8 in. (15.875 mm)	
Reducer for blade to arbor	n/a	Ø 5/8 x 1 x 0.11 in. (16 x 25.4 x 2.8 mm)
Saw blade	Ø10in. x 40T x 5/8in. arbor, carbide tipped, (Ø254 x 15.875 x 2.8mm – 40T); Nmax. 7000 RPM	Ø12in. x 48T x 1in. arbor, carbide tipped, (Ø305 x 25.4T x 2.8mm – 48T); Nmax. 7000 RPM
Blade arbor size	5/8 in. (15.875 mm)	1 in. (25.4 mm)
Miter cutting range	52° Left, 60° Right	
Bevel cutting range	0° to 45° L & R	
Miter stops	0, 15, 22.5, 31.6, 45 deg. L & R and 60 deg. R	
Bevel stops	45° L, 0°, 45° R	
Maximum sliding travel	9-3/8 in. (240 mm)	9.2 in. (233 mm)
Cutting capacity	See Table 2	
Dust collection		
Dust port diameter	Ø 1-5/8 in. (40.6 mm)	
Adaptor diameters	Ø 1-5/8 in. (40.6 mm) to 2-1/2 in. (63 mm)	
Main materials		
Work table	Aluminum	
Base	Aluminum	
Extension support	Aluminum	
Upper blade guard	Aluminum	
Lower blade guard	PC	
Slide bar	Steel	
Upper sliding fence	Aluminum	
Lower fixed fence	Aluminum	
Dimensions		
Machine overall dimensions, LxWxH	43-1/2 x 29-1/2 x 28-1/2 in. (1100 x 750 x 720 mm)	47-1/2 x 30 x 30-5/8 in. (1200 x 760 x 780 mm)
Shipping dimensions, LxWxH	37-3/8 x 24-7/8 x 14-1/2 in. (950 x 630 x 370 mm)	41-3/4 x 26 x 17-3/8 in. (1060 x 660 x 440 mm)

Weights		
Net weight (approx.)	47 lbs. (21 kg)	56 lbs. (25 kg)
Shipping weight (approx.)	54 lbs. (24 kg)	62 lbs. (28 kg)

5.1 Cutting capacities

Table 2

			JMS-10X	JMS-12X
Type of cut	Miter angle	Bevel angle	Capacity	
Cross cut	0°	0°	12 x 3-9/16 in. (305 x 90 mm)	14 x 4.0 in. (355 x 100 mm)
Miter cut	45° L & R	0°	8-1/2 x 3-9/16 in. (215 x 90 mm)	10 x 4.0 in. (254 x 100 mm)
Bevel cut	0°	45° L	12 x 1-9/16 in. (305 x 40 mm)	14 x 2.0 in. (355 x 50 mm)
Bevel cut	0°	45° R	12 x 1.0 in. (305 x 25 mm)	14 x 1-3/8 in. (355 x 35 mm)
Compound	45° L & R	45° L	8-1/2 x 1-9/16 in. (215 x 40 mm)	10 x 2.0 in. (254 x 50 mm)
Compound	45° L & R	45° R	8-1/2 x 1.0 in. (215 x 25 mm)	10 x 1-3/8 in. (254 x 35 mm)

¹ subject to local and national electrical codes.

² The specified values are emission levels and are not necessarily to be seen as safe operating levels. As workplace conditions vary, this information is intended to allow the user to make a better estimation of the hazards and risks involved only.

L = length, W = width, H = height

L & R = Left and Right

n/a = not applicable

The specifications in this manual were current at time of publication, but because of our policy of continuous improvement, JET reserves the right to change specifications at any time and without prior notice, without incurring obligations.

⚠WARNING Read and understand the entire contents of this manual before attempting assembly or operation. Failure to comply may cause serious injury.

6.0 Setup and assembly

6.1 Unpacking

Inspect contents for shipping damage or missing parts. If either is discovered, report it to your distributor.

Do not discard carton or packing material until saw is assembled and running satisfactorily.

6.2 Shipping contents

- 1 Miter saw
- 1 Dust bag
- 1 Dust port adaptor
- 1 Hold-down clamp assembly
- 3 Hex wrenches, 2.5/3/6 mm
(6mm wrench is preinstalled in rear handle)

6.3 Tools required for assembly

Hex wrenches – 2.5mm, 6mm

(Additional tools may be needed for adjustment procedures and securing the miter saw to a workbench.)

6.4 Transporting the saw

Observe the following safety measures to avoid injury from unexpected saw movement:

- Disconnect power cord and wrap it around the storage clips.
- Bring cutting head to forward position and down, and lock it in lower position.
- Lock slide carriage in place.
- Always use the carrying handles when lifting or moving to avoid damage to machine.
- Bend at the knees, not from the back.

6.5 Mounting saw to bench

For stationary use:

Select a location for the saw, such as the top of a workbench, that provides sufficient room for handling workpieces. Secure the saw to the bench. Mounting hardware is not included and must be purchased separately.

For portable use:

Place saw on a 3/4-in. thick piece of plywood and bolt the base securely to the plywood using the mounting holes on base. Mounting hardware is not included and must be purchased separately.

Use C-clamps to clamp this mounting board to a stable work surface at the worksite.

6.6 Releasing slide carriage

Loosen slide locking knob (A, Figure 8-1).

⚠CAUTION When transporting or storing miter saw, the slide carriage should always be locked in position.

6.7 Releasing cutting head

⚠WARNING When not in use, lock cutting head in down position. Failure to comply can cause serious injury or equipment damage.

1. Push down on operating handle.
2. Pull out on head release pin (B, Figure 6-1).
3. Raise cutting head to UP position.

Note: When not in use, lock cutting head in down position:

4. Pull out on head release pin (B) and bring cutting head down.
5. Push in head release pin (B) to lock.

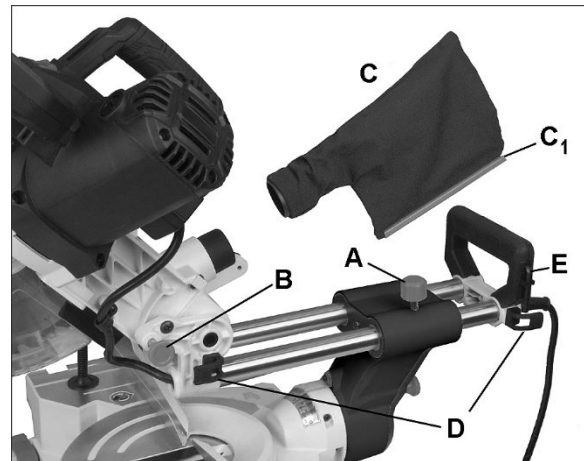

Figure 6-1

6.8 Dust extraction

6.8.1 Dust bag

Push dust bag onto exhaust port (Figure 6-1).

To empty dust bag, remove it from exhaust port, slide off plastic clip (C₁, Figure 6-1) and empty sawdust through bag opening. Reinstall clip before using dust bag.

Note: Inspect and empty bag frequently; do not wait for it to become full.

6.8.2 Adaptor

The adaptor can be used to convert the 1-5/8 in. diameter port to 2-1/2 in. diameter, for connection to a hose used with a shop vacuum or other dust collection system. Use a hose clamp to secure the dust hose (not provided) to the saw port.

6.9 Power cord storage clips

The slide carriage has two clips for cord storage when machine is not in use (D, Figure 6-1).

6.10 Saw blade wrench

The hex wrench used for blade changing is stored in the rear handle (E, Figure 6-1). The hex wrench also has a cross-point driver on its opposite end.

6.11 Installing hold-down

1. Insert hold-down post (F, Figure 6-2) into mounting hole located behind left or right fence.
2. Loosen knob (G) to raise or lower clamp support, then tighten knob.
3. Press button (H) to allow clamp to drop onto workpiece, then use knob (J) to tighten clamp against workpiece.

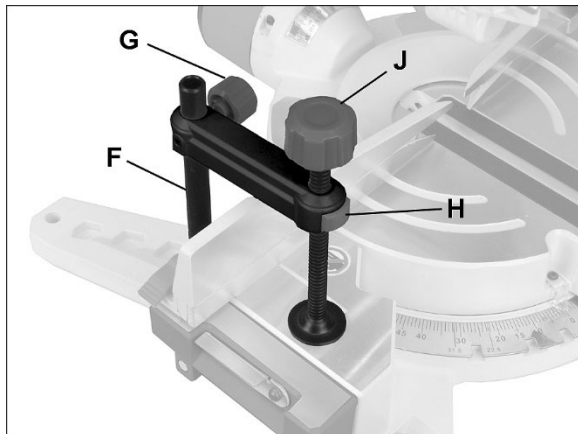

Figure 6-2

6.12 Removing/installing blade

⚠WARNING Disconnect power (unplug) to avoid accidental starts. Failure to comply may cause serious injury.

1. Unplug saw from electrical outlet.
2. Raise cutting head to upright position.
3. Raise lower blade guard to uppermost position and hold. See Figure 6-3.
4. Loosen cover plate screw (K, Figure 6-3) with provided crosspoint tool.

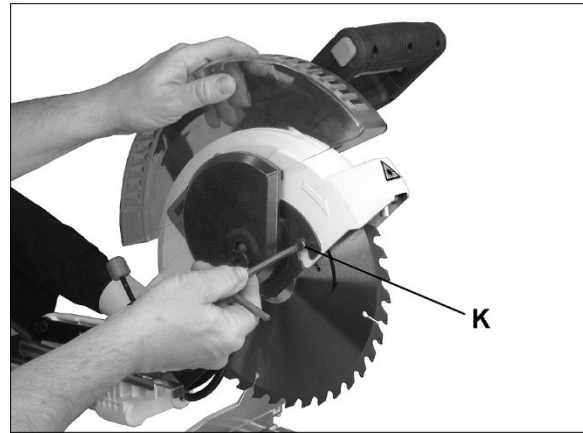

Figure 6-3

5. Allow cover plate and guard to fall backward, to expose arbor bolt (L, Figure 6-4).
6. Press and hold arbor lock on opposite side of head (Figure 6-5) while rotating blade until arbor lock engages.
7. Continue pressing arbor lock, while loosening arbor bolt with hex wrench. **NOTE:** Left-hand threads – turn *clockwise* to loosen.

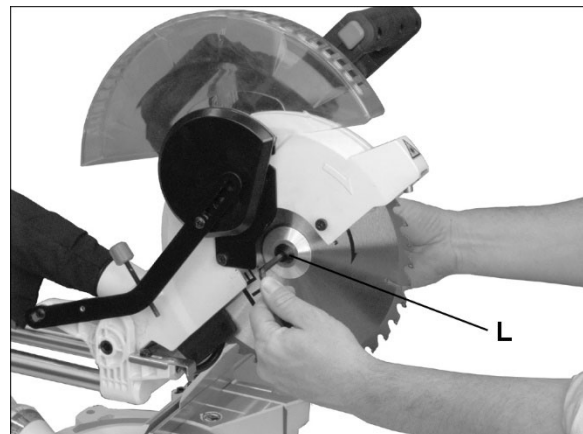

Figure 6-4

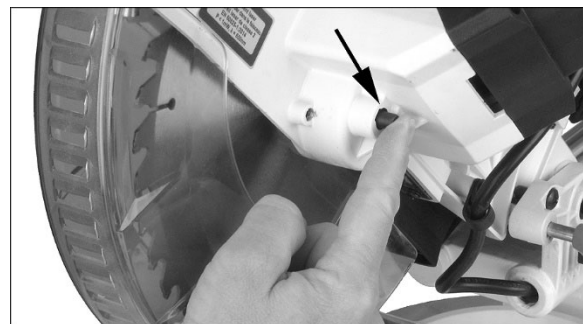

Figure 6-5

8. Remove arbor bolt, outer flange, and blade. (On model JMS-12X, also remove reducer sleeve). See Figure 6-6. Do not remove inner flange.

Note: Pay attention to the pieces removed, noting their position and direction they face. Wipe pieces clean of any sawdust before installing a new blade.

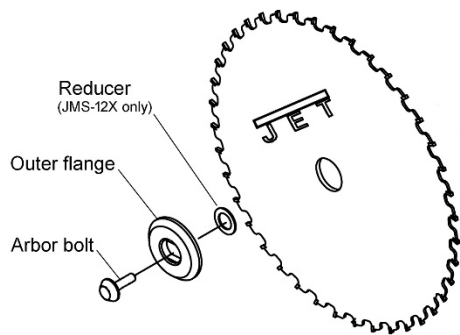

Figure 6-6

Important: Make sure blade size and arbor hole match specification of miter saw.

9. Install new blade. Rotation arrow on blade must match clockwise rotation arrow on upper guard, and the blade teeth must point downward.
10. Place flange outer flange against blade and on arbor. Thread arbor bolt onto arbor in *counterclockwise* direction.

Important: Make sure flat edge inside flange opening is aligned with flat edge on arbor shaft. Also, the flat -side of the flange must be placed against blade.

6. Press and hold arbor lock (Figure 6-5) while rotating blade until arbor lock engages.
7. Tighten arbor bolt.
8. Rotate cover plate back to original position, until slot in cover plate engages completely with cover plate screw (K, Figure 6-3). While holding lower blade guard up as shown in Figure 6-3, tighten screw.
9. Lower blade guard and verify that it operates smoothly without binding or sticking.

⚠WARNING Never use saw without cover plate securely in place and screw tightened down. Failure to comply may cause serious injury.

If arbor bolt should accidentally loosen, the cover plate prevents it from falling out, and helps prevent the spinning blade from coming off the saw.

⚠WARNING Verify that the flanges are clean and properly installed. Lower the blade into the table and verify that it does not come into contact with the base, table, or table inserts. Failure to comply may cause serious injury.

7.0 Electrical connections

⚠WARNING To avoid electrical hazards, fire hazards, or damage to the machine, use proper circuit protection. Your saw is wired at the factory for 115V operation. Connect to a 120V, 15 Amp circuit and use a 15 amp time delay fuse or circuit breaker. If power cord is worn or cut, or damaged in any way, have it replaced immediately to avoid shock or fire.

Before connecting to power source, be sure switch is in *off* position.

This machine is double insulated to provide a double thickness of insulation between the user and the machine's electrical system. All exposed metal parts are isolated from the internal metal motor components with protective insulation.

This saw has a plug that looks like the one shown in Figure 7-1.

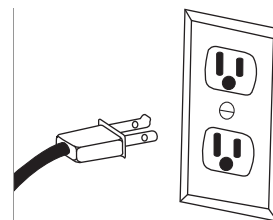

Figure7-1

To reduce the risk of electrical shock, this saw has a polarized plug (one blade is wider than the other). This plug will fit in a polarized outlet only one way; if the plug does not fit fully in the outlet, reverse the plug. If it still does not fit, contact a qualified electrician to install the proper outlet. Do not alter the plug in any way.

Double insulation does not take the place of normal safety precautions when operating this tool.

To avoid electrocution:

1. Use only identical replacement parts when servicing a tool with double insulation. Servicing should be performed by a qualified technician.
2. Do not use power tools in wet or damp locations or expose them to rain or snow.

7.1 Extension cords

The use of extension cords is discouraged; try to position equipment within reach of the power source. If an extension cord becomes necessary, be sure it is heavy enough to carry the current your product will draw. An undersized cord will cause a drop in line voltage resulting in loss of power and overheating.

Table 3 shows recommended size to use depending on cord length and nameplate ampere rating. If in doubt, use the next heavier gauge. The smaller the gauge number, the heavier the cord.

Cord length	Wire gauge (AWG)
0 – 25 ft.	16
25- 50 ft.	14

Table 3

Important: Make certain the receptacle in question is properly grounded. If you are not sure, have a registered electrician check the receptacle.

8.0 Adjustments

Note: Your miter saw was adjusted by the manufacturer. However, during shipment slight misalignment may have occurred. Check the following settings and adjust if necessary prior to using this miter saw.

8.1 Support foot

The foot (A, Figure 8-1) can be turned in or out to adjust its height. It is designed to provide support for the miter table when locking handle is pushed down or when cutting head is brought forward for slide-cutting. The foot should be adjusted to contact surface of bench or worktable.

8.2 Miter angle setting

The miter scale shows miter angles from 0° to 52° to the left, and 0° to 60° to the right.

To set miter angle:

1. Lift up on miter lock handle (B, Figure 8-1) to unlock table.
2. Press and hold release button (C) and use miter lock handle to push cutting arm until desired degree aligns with angle indicator (D).
3. Push down miter lock handle (B) to lock the position.

Note: The release button (C) can be continuously engaged to bypass the stops. This is convenient when frequent and quick adjustment of miter angles is needed.

1. Push down release button (C) and push in pin (E). Release button is now continuously engaged.
2. Grasp handle (B) and freely rotate cutting arm.
3. Press release button (C) again to disengage pin.

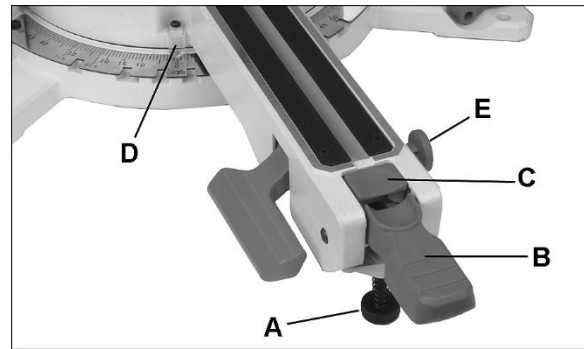

Figure 8-1: selecting miter angles

8.2.1 Miter positive stop selection

The miter saw table has preset stops for quick and accurate positioning at common angle settings of 0°, 15°, 22.5°, 31.6°, and 45° left and right; and 60° right.

1. Lift up on miter lock handle (B, Figure 8-1) to unlock table.
2. Press release button (C) and move table with handle (B). As scale indicator approaches the desired degree, release the button (C). The table will engage the next positive stop.
3. Push down miter lock handle (B) to lock the position.

8.2.2 Miter scale indicator alignment

1. Rotate table to the 0° stop.
2. If indicator (D, Figure 8-1) does not align with zero on scale, loosen screw and adjust indicator to 0° mark. Retighten screw.

8.3 Table extensions and work stop

Pull up lock handle (H, Figure 8-2) and slide table extension outward, as shown. Push down lock handle to secure position.

Raise workstop (J) for quick positioning of stock when cutting multiple pieces of equal length.

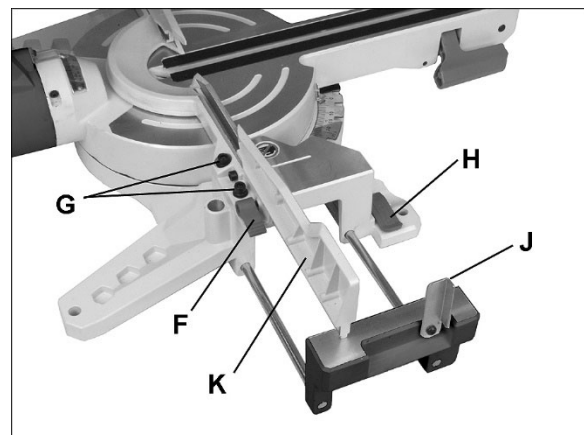

Figure 8-2

8.4 Fence adjustment

⚠WARNING The fence extensions must be extended to left or right, or removed entirely, when making bevel cuts, to prevent blade or guard obstruction. Failure to comply may cause serious injury.

Failure to extend the fence will not allow enough space for the blade to pass through. This could result in serious injury. At extreme miter or bevel angles the saw blade may also contact the fence resulting in damage to equipment as well as personal injury.

IMPORTANT: Make a “dry run” of the cut, including downward and sliding paths, and resolve any potential fence obstructions before turning on the saw.

To adjust fence:

1. Raise lock handle (F, Figure 8-2) to unlock fence extension.
2. Slide fence extension (K) outward to accommodate desired bevel angle, or slide it completely off.
3. Push down lock handle (F) to tighten fence extension in position.

Note: Secure fence extensions in position closest to saw blade when transporting the miter saw.

8.4.1 Checking fence squareness

1. Unplug saw from electrical outlet.
2. Loosen four fence locking screws (G, Figure 8-2). Note: Two locking screws to each fence.
3. Lower cutting head and lock in position.
4. Place a combination square against fence and blade, as shown in Figure 8-3.

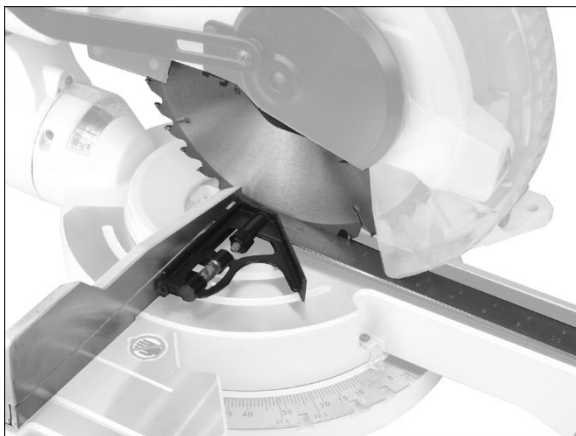

Figure 8-3

5. Adjust fence square to blade and tighten the four fence locking screws (G, Figure 8-2).
6. After fence has been aligned, use a scrap piece of wood to make a cut at 90°, then check squareness of the piece. Readjust if necessary.

8.5 Bevel adjustments

8.5.1 90° (zero) bevel stop adjustment

1. Unplug saw from electrical outlet.
2. Pull up bevel lock handle (A, Figure 8-4) to unlock tilt mechanism.
3. Pull out on bevel pin (B, Figure 8-4) and tilt cutting arm to 90° position (0° on bevel scale) against positive stop.
4. Push down lock handle (A) to secure cutting head angle.

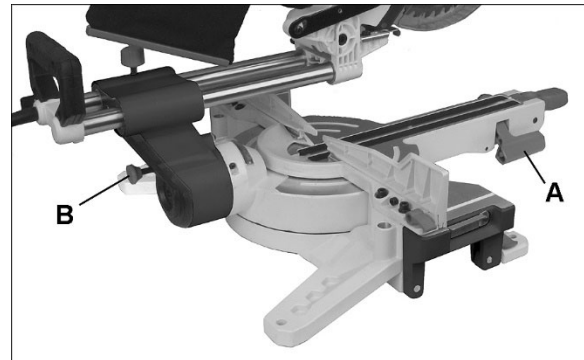

Figure 8-4

NOTE: If lock handle (A) is disengaged and bevel pin (B) has been pulled out, but cutting head still refuses to tilt, the lock nut may have been overtightened for shipping purposes. Remove three screws and open rear cover (see Figure 8-5). Slightly loosen lock nut (N, Figure 8-5) with wrench. Reinstall rear cover. This adjustment is *only if necessary*.

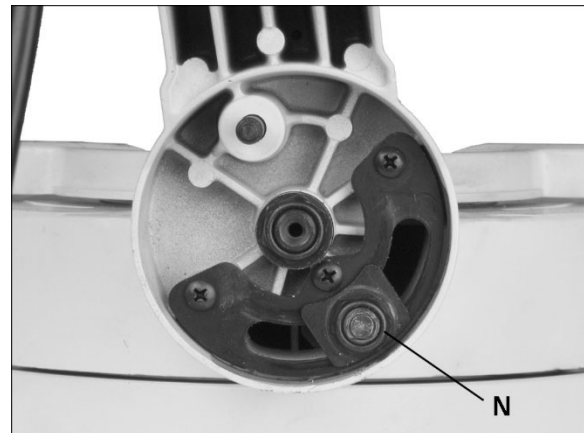

Figure 8-5

5. Place a combination square flat on the table and against blade, as shown in Figure 8-6. **Note:** Position the square flush against main blade surface, not against a projecting blade tooth.

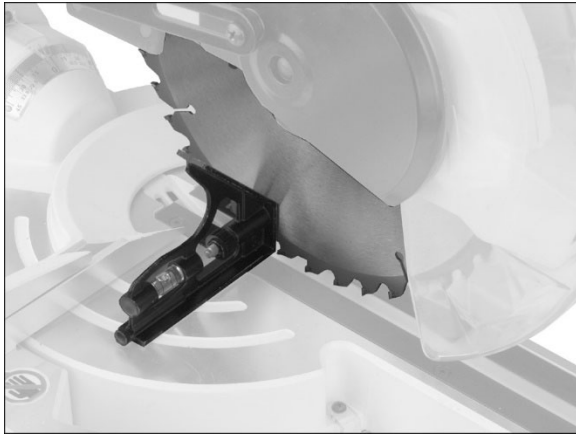

Figure 8-6

6. If blade is not 90° to miter table (i.e. square does not sit flush against both surfaces), turn right set screw (E, Figure 8-7) in or out until blade is 90° to table.
7. If needed, loosen screw (D, Figure 8-7) and adjust bevel angle indicator to align with zero on scale. Retighten screw.

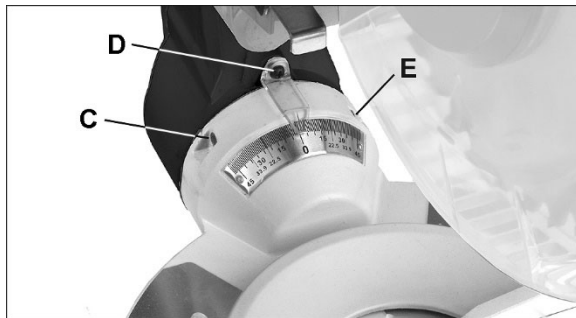

Figure 8-7

8.5.2 45° bevel stop adjustment

1. Unplug saw from electrical outlet.
2. Make sure 90-degree bevel stop is accurate (sect. 8.5.1).
3. Set miter angle to zero degrees. Fully extend both sliding fences to prevent obstruction.
4. Pull up bevel lock handle (A, Figure 8-4).
5. Pull out bevel lock pin (B, Figure 8-4) and tilt cutting head to 45-degrees left. The cutting head should stop at the 45-degree mark on scale.
10. If adjustment is needed, turn left set screw (C) as needed to bring cutting head to 45-degree mark on scale. Verify the setting using a 45-degree angle tool on the table and against blade.

Note: The left set screw (C, Figure 9-7) may be used instead to set a different angle stop, less than 45°, that is used frequently by the operator.

The right 45° tilt stop will have already been established when the 90° setting is calibrated in sect. 8.5.1.

8.6 Depth adjustment

Cutting depth can be pre-set for even and repetitive shallow cuts, such as slots or dadoes.

1. Raise cutting head.
2. Loosen screw (F, Figure 8-8) and slide plate (G) outward. Retighten screw.
3. Pull cutting head down until blade teeth are at desired depth of cut.
4. Hold cutting head in this position and turn stop screw (H) until it touches plate (G).
5. Rotate knurled nut (J) against casting to secure setting.
6. Recheck blade depth by moving cutting head front to back through the full motion of a typical cut along the control arm.

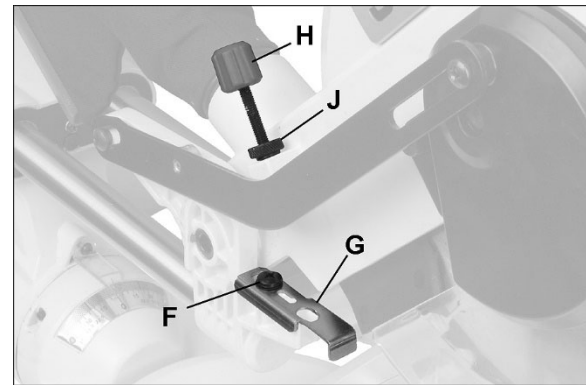

Figure 8-8

9.0 Operation

⚠WARNING Before operating miter saw, make sure that you have read and thoroughly understand all safety instructions in sect. 1.0. Failure to comply may result in serious injury.

Before operating miter saw, verify that blade will not be obstructed. Remove fence extensions if needed. Failure to comply may result in serious injury and/or damage to saw.

Make sure all locking handles function properly. A malfunctioning locking handle can present a safety hazard.

9.1 LED light

Use rocker switch atop handle to turn light on and off. See Figure 4-1.

9.2 Laser guide

⚠WARNING Laser radiation. Avoid direct eye exposure. The use of optical instruments with this product will increase eye hazard. Refer to Figure 9-1.



Figure 9-1

Use rocker switch atop handle to turn laser guide on and off (see Figure 4-1). The laser must align with blade cutting path.

The laser has no user-adjustments. If you suspect realignment is necessary, take the miter saw to an approved service center.

⚠WARNING Do not attempt to repair or disassemble the laser. If unqualified persons attempt to repair this laser product, serious injury may result. Any repair or adjustment required on this laser product should be performed by authorized service center personnel.

9.3 General saw operation

9.3.1 Starting the cut

1. Set desired bevel and/or miter angles and lock the settings. See *sect. 8.2* and *8.5*.
2. Place hands a safe distance away from blade path.
3. Hold workpiece firmly against fence to prevent it creeping toward blade. Use hold-down clamp whenever possible.
4. Perform a “dry run” – bring blade down to workpiece to confirm cutting path of blade, and ensure that no obstacles are present. If needed, slide the fence extension(s) away or remove them entirely.
5. Position blade just above the workpiece. Press release button on either left or right side of operating handle, and press trigger (see Figure 4-1) to start saw. *Blade must NOT be contacting workpiece when trigger is pressed.*
6. Lower blade into workpiece with a firm downward motion.

9.3.2 Finishing the cut

7. Hold cutting head in down position.
8. Release trigger and wait for all moving parts to stop before moving your hands and raising cutting arm.

Note: The miter saw is equipped with an electrical blade brake. When trigger is released, the brake will automatically stop the blade in approximately 3 seconds.

9.4 Jammed material

If a jam occurs, release trigger and wait for all moving parts to stop. *Unplug saw* and remove jammed items.

9.5 Cutting options

9.5.1 Chop cuts

For chop cutting operations on small workpieces, slide cutting head completely toward rear of unit and tighten slide lock knob (A, Figure 8-1). Follow general cutting procedures of *sect. 9.3*.

9.5.2 Sliding cuts

To cut wide boards, loosen slide lock knob (A, Figure 8-1) to allow cutting head to slide freely. See specifications for maximum slide capacity of your saw.

⚠WARNING Observe these precautions:

- Never pull cutting head assembly and spinning blade toward you during the cut.
- Allow blade to reach full speed before cutting.
- Extend fence by sliding it out to required location, or
- Remove right sliding fence if necessary.
- Return carriage to full rear position after each crosscut operation.

To crosscut boards that are wider than the length of the saw blade, proceed as follows:

1. Set desired bevel and/or miter angles and lock the settings. See *sect. 8.2* and *8.5*.
2. Position workpiece against fence and clamp it to the table.
3. Loosen slide lock knob (A, Figure 8-1).
4. Grasp operating handle and pull cutting head forward until center of saw blade is over front of workpiece.
5. Press release button and trigger to turn on saw.
6. When saw reaches full speed, push handle down slowly, cutting through leading edge of workpiece.
7. Slowly push operating handle back toward fence to complete the cut. Do not use excessive force; allow blade to do the cutting.
8. Release trigger and allow blade to stop spinning before allowing cutting head to rise.

9.5.3 Miter cutting

Rotate table to desired miter angle as shown on miter scale. Refer to *sect. 8.2*.

The miter setting can be locked down at any angle from 52° left to 60° right.

Miter stops are provided at common angles of 0°, 15°, 22.5°, 31.6°, 45° left and right, and 60° right.

Always push down miter lock handle (B, Figure 8-1) to secure table in position.

9.5.4 Bevel cutting

Tilt cutting head to desired angle as shown on bevel scale. Refer to *sect. 8.5.1*.

The blade can be tilted at any angle, from 90° straight cut (0° on scale) to 45° left and right bevel. Always push down bevel lock handle (A, Figure 9-4) to secure cutting head in position.

Bevel positive stops are provided at 0° and 45° left and right.

9.5.5 Compound cuts

A compound cut involves both miter and bevel angles in the same operation.

The charts in *sect. 11.0* show miter and bevel settings for specific angles of compound cuts.

9.6 Cutting bowed material

A curved or warped workpiece must be secured against the fence and with a clamping device used. To help prevent binding, place convex side of workpiece against fence. An extremely warped piece should not be used.

9.7 Rough cutting a dado

1. Mark lines identifying width and depth of desired cut on the workpiece and position on the table so that inside tip of blade is positioned on the line. Use hold down clamp to secure workpiece.
2. Set cutting depth as described in *sect. 8.6*.
3. Cut two parallel grooves, then remove the material between them.

9.8 Base molding

Base moldings and many other moldings can be cut on a compound miter saw. The setup of the saw depends on molding characteristics and application. Perform practice cuts on scrap material to achieve best results.

- Make sure that moldings rest firmly against fence and table. Use hold-down, crown molding vise or C-clamps, whenever possible, and place tape on the area being clamped to avoid marks.
- Reduce splintering by taping the cut area prior to making the cut. Mark the cut line directly on the tape.
- Splintering typically happens due to an incorrect blade application and thinness of the material.

Note: Always perform a dry run cut so you can determine if the operation being attempted is possible before power is applied to the saw.

9.9 Crown molding

Your compound miter saw is suited for the difficult task of cutting crown molding. To fit properly, crown molding must be compound-mitered with extreme accuracy. The two surfaces on a piece of crown molding that fit flat against the ceiling and wall are at angles that, *when added together, equal exactly 90°*.

Most crown molding has a top rear angle (the section that fits flat against the ceiling) of 52° and a bottom rear angle (the section that fits flat against the wall) of 38°.

In order to accurately cut crown molding for a 90° inside or outside corner, lay the molding with its broad back surface flat on the saw table.

When setting the bevel and miter angles for compound miters, remember that the settings are interdependent – changing one changes the other.

10.0 User-maintenance

⚠WARNING Always disconnect power to the machine (unplug) before performing maintenance. Failure to comply may result in serious personal injury.

Never use gasoline or any highly volatile solvents to clean the miter saw.

Use only replacement parts that are identical to the parts list at the end of this manual and reassemble exactly as the original assembly to avoid electrical shock.

10.1 General cleaning

- Wipe off machine with a dry cloth. Use a bristle brush for hard-to-reach areas.
- Vacuum or blow out motor air vents.

⚠WARNING Wear proper eye and respiratory protection when using compressed air.

- Periodically, saw dust will accumulate under saw table and base. This could cause difficulty in the movement of the table when setting up a miter cut. Frequently blow out or vacuum up the saw dust. Turn saw over and blow out dust from beneath saw table.
- Wipe dust/debris off the slide bars.
- Clean out the fence extension trackways.
- Remove table inserts to clear away any small pieces beneath. Reinstall table inserts before operating.

10.2 Lower Blade Guard

Do not use saw without lower blade guard. The lower blade guard is attached to the saw for your protection. Should the lower guard become damaged, do not use saw until the damaged guard has been replaced. Develop a regular check to make sure the lower guard is working properly. Clean the lower guard of any dust or buildup with a damp cloth.

⚠WARNING When cleaning lower guard, unplug saw from power source receptacle to avoid unexpected startup.

⚠WARNING Do not use solvents on lower blade guard; they could make the plastic “cloudy” and brittle.

10.3 Lubrication

All motor bearings in this tool are lubricated with a sufficient amount of high grade lubricant for the life of the unit under normal operating conditions; therefore, no further lubrication is required.

Lubricate the following as necessary. Use a light household oil, such as sewing machine oil. Avoid excessive oil, to which saw dust will cling.

- Chop pivot and spring.
- Central pivot of plastic guard: Use light machine oil on metal-to-metal or metal-to-plastic guard contact areas as required for smooth, quiet operation.
- Table extension rods.

10.4 Commutator brush inspection

To maintain motor efficiency, inspect the two carbon brushes every two months, or more frequently if saw is heavily used. Stalling or loss of power may be a symptom of worn carbon brushes. If one brush is worn out, replace both at the same time.

⚠CAUTION Continued use of damaged or worn brushes may result in damage to motor armature.

1. Unplug saw from power source.
2. Unscrew and remove cap with a flat blade screwdriver. See Figure 10-1. Note: Unscrew cap cautiously – the brush spring will push it out.

3. Pull out brush assembly. Notice orientation of brush as you remove it; it should be inserted in the same manner; curvature of brush will match curvature of motor. (This will avoid a break-in period that reduces motor performance and increases wear.)
4. Inspect brush; it should be replaced if any of the following are discovered:
 - Brush has worn to about 1/4-inch long.
 - Signs of crumbling, burning or breaking.
 - End of brush is rough or pitted.
 - Abnormal coloration of spring
 - Broken lead in spring
 - Collapsed spring
5. Install new brush (or reinstall current brush) and gently press it all the way into hole.
6. Install cap snugly, but do not overtighten.
7. Repeat for other brush.

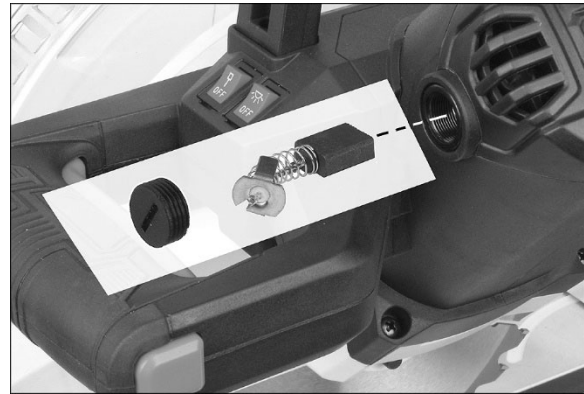

Figure 10-1

10.5 Additional servicing

Any additional servicing should be performed by authorized service personnel.

11.0 Crown molding charts

11.1 Crown molding: 90° wall angles

Crown molding compound cut with 90° walls.

Type of Cut	Key	Bevel Setting	Miter Setting	Procedure
Inside corner – Left Side	IL	33.9°	31.6° Right	<ol style="list-style-type: none"> 1. Position top of molding against fence. 2. Miter table set at RIGHT 31.6°. 3. LEFT side is finished piece.
Inside corner – Right Side	IR	33.9°	31.6° Left	<ol style="list-style-type: none"> 1. Position bottom of molding against fence. 2. Miter table set at LEFT 31.6°. 3. LEFT side is finished piece.
Outside corner – Left Side	OL	33.9°	31.6° Left	<ol style="list-style-type: none"> 1. Position bottom of molding against fence. 2. Miter table set at LEFT 31.6°. 3. RIGHT side is finished piece.
Outside corner – Right Side	OR	33.9°	31.6° Right	<ol style="list-style-type: none"> 1. Position top of molding against fence. 2. Miter table set at RIGHT 31.6°. 3. RIGHT side is finished piece

Table 4

11.2 Crown molding: various wall angles

Compound *miter* and *bevel* angle settings for wall-to-crown molding angles.

Angle Between Walls	52/38° Crown Molding		45/45° Crown Molding	
	Miter Setting	Bevel Setting	Miter Setting	Bevel Setting
67	42.93	41.08	46.89	36.13
68	42.39	40.79	46.35	35.89
69	41.85	40.50	45.81	35.64
70	41.32	40.20	45.28	35.40
71	40.79	39.90	44.75	35.15
72	40.28	39.61	44.22	34.89
73	39.76	39.30	43.70	34.64
74	39.25	39.00	43.18	35.38
75	38.74	38.69	42.66	34.12
76	38.24	38.39	42.15	33.86
77	37.74	38.08	41.64	33.60
78	37.24	37.76	41.13	33.33
79	36.75	37.45	40.62	33.07
80	36.27	37.13	40.12	32.80
81	35.79	36.81	39.62	32.53
82	35.31	36.49	39.13	32.25
83	34.83	36.17	38.63	31.98
84	34.36	35.85	38.14	31.70
85	33.90	35.52	37.66	31.42
86	33.43	35.19	37.17	31.34
87	32.97	34.86	36.69	30.86
88	32.52	34.53	36.21	30.57
89	32.07	34.20	35.74	30.29
90	31.62	33.86	35.26	30.00
91	31.17	33.53	34.79	29.71
92	30.73	33.19	34.33	29.42
93	30.30	32.86	33.86	29.13
94	29.86	32.51	33.40	28.83
95	29.43	32.17	32.94	28.54
96	29.00	31.82	32.48	28.24
97	28.58	31.48	32.02	27.94
98	28.16	31.13	31.58	27.64
99	27.74	30.78	31.13	27.34
100	27.32	30.43	30.68	27.03
101	26.91	30.08	30.24	26.73
102	26.50	29.73	29.80	26.42
103	26.09	29.38	29.36	26.12
104	25.69	29.02	28.92	25.81
105	25.29	28.67	28.48	25.50
106	24.89	28.31	28.05	25.19
107	24.49	27.96	27.62	24.87
108	24.10	27.59	27.19	24.56
109	23.71	27.23	26.77	24.24
110	23.32	26.87	26.34	23.93
111	22.93	26.51	25.92	23.61
112	22.55	26.15	25.50	23.29
113	22.17	25.78	25.08	22.97
114	21.79	25.42	24.66	22.66
115	21.42	25.05	24.25	22.33
116	21.04	24.68	23.84	22.01
117	20.67	24.31	23.43	21.68
118	20.30	23.94	23.02	21.36
119	19.93	23.57	22.61	21.03
120	19.57	23.20	22.21	20.70
121	19.20	22.83	21.80	20.38
122	18.84	22.46	21.40	20.05
123	18.48	22.09	21.00	19.72

Angle Between Walls	52/38° Crown Molding		45/45° Crown Molding	
	Miter Setting	Bevel Setting	Miter Setting	Bevel Setting
124	18.13	21.71	20.61	19.39
125	17.77	21.34	20.21	19.06
126	17.42	20.96	19.81	18.72
127	17.06	20.59	19.42	18.39
128	16.71	20.21	19.03	18.06
129	16.37	19.83	18.64	17.72
130	16.02	19.45	18.25	17.39
131	15.67	19.07	17.86	17.05
132	15.33	18.69	17.48	16.71
133	14.99	18.31	17.09	16.38
134	14.66	17.93	16.71	16.04
135	14.30	17.55	16.32	15.70
136	13.97	17.17	15.94	15.36
137	13.63	16.79	15.56	15.02
138	13.30	16.40	15.19	14.62
139	12.96	16.02	14.81	14.34
140	12.63	15.64	14.43	14.00
141	12.30	15.25	14.06	13.65
142	11.97	14.87	13.68	13.31
143	11.64	14.48	13.31	12.97
144	11.31	14.09	12.94	12.62
145	10.99	13.71	12.57	12.29
146	10.66	13.32	12.20	11.93
147	10.34	12.93	11.83	11.59
148	10.01	12.54	11.46	11.24
149	9.69	12.16	11.09	10.89
150	9.37	11.77	10.73	10.55
151	9.05	11.38	10.36	10.20
152	8.73	10.99	10.00	9.85
153	8.41	10.60	9.63	9.50
154	8.09	10.21	9.27	9.15
155	7.77	9.82	8.91	8.80
156	7.46	9.43	8.55	8.45
157	7.14	9.04	8.19	8.10
158	6.82	8.65	7.83	7.75
159	6.51	8.26	7.47	7.40
160	6.20	7.86	7.11	7.05
161	5.88	7.47	6.75	6.70
162	5.57	7.08	6.39	6.35
163	5.26	6.69	6.03	6.00
164	4.95	6.30	5.68	5.65
165	4.63	5.90	5.32	5.30
166	4.32	5.51	4.96	4.94
167	4.01	5.12	4.61	4.59
168	3.70	4.72	4.25	4.24
169	3.39	4.33	3.90	3.89
170	3.08	3.94	3.54	3.53
171	2.77	3.54	3.19	3.10
172	2.47	3.15	2.83	2.83
173	2.15	2.75	2.48	2.47
174	1.85	2.36	2.12	2.12
175	1.54	1.97	1.77	1.77
176	1.23	1.58	1.41	1.41
177	0.92	1.18	1.06	1.06
178	0.62	0.79	0.71	0.71
179	0.31	0.39	0.35	0.35

Table 5

12.0 Troubleshooting JMS-10X,12X Miter Saws

Symptom	Possible Cause	Correction *
Motor will not start	No incoming power.	Check plug connection to receptacle. If satisfactory, check electrical panel for blown fuse or tripped breaker – replace fuse or reset breaker.
	Low voltage.	Correct the low voltage conditions.
	Faulty power cord or plug.	Have cord and plug inspected by a qualified service center.
	Open circuit in motor or loose connection.	Have motor inspected by a qualified service center.
Motor will not start: fuse blows or circuit breaker trips.	Short circuit in line cord or plug.	Inspect cord or plug for damaged insulation and shorted wires.
	Open circuit in motor or loose connection.	Have motor inspected by a qualified service center.
	Incorrect fuses or circuit breakers in power line.	Install correct fuses or circuit breakers.
Motor overheats.	Motor overloaded.	Reduce pressure on workpiece. Allow saw to cool down before restarting.
	Extension cord too long or not proper gauge.	Use shorter extension cord, or larger gauge.
	Air circulation through motor is restricted.	Blow out motor vents with compressed air to restore normal air circulation.
Motor stalls, or fails to reach full speed.	Motor overloaded.	Reduce pressure on workpiece.
	Improper extension cord.	Use proper extension cord.
	Low voltage.	Correct the low voltage conditions.
	Air circulation through motor is restricted.	Blow out motor vents with compressed air to restore normal air circulation.
	Motor failure.	Have motor inspected by a qualified service center.
	Incorrect fuses or circuit breakers in power line.	Install correct fuses or circuit breakers.
Machine slows when operating.	Applying too much pressure to workpiece.	Feed workpiece more slowly.
Cuts not square.	Fence not parallel to blade	Align fence square to blade.
	90-degree stop is misaligned.	Adjust 90-degree stop.
Poor cutting performance.	Blade is dull.	Sharpen or replace blade.
	Workpiece is creeping during cut.	Adjust hold-down for better clamping.
	Blade not appropriate for material being cut.	Use proper blade for selected material.
Blade coasts after trigger is released.	Electrical blade brake malfunction.	Have saw inspected by a qualified service center.

Table 6

***Warning:** Some corrections may require a qualified electrician.

13.0 Replacement Parts

Replacement parts are listed on the following pages. To order parts or reach our service department, call 1-800-274-6848 Monday through Friday, 8:00 a.m. to 5:00 p.m. CST. Having the Model Number and Serial Number of your machine available when you call will allow us to serve you quickly and accurately.

Non-proprietary parts, such as fasteners, can be found at local hardware stores, or may be ordered from JET.

Some parts are shown for reference only, and may not be available individually.

13.1.1 JMS-10X (#707210) – Miter Saw Assembly – Exploded View I

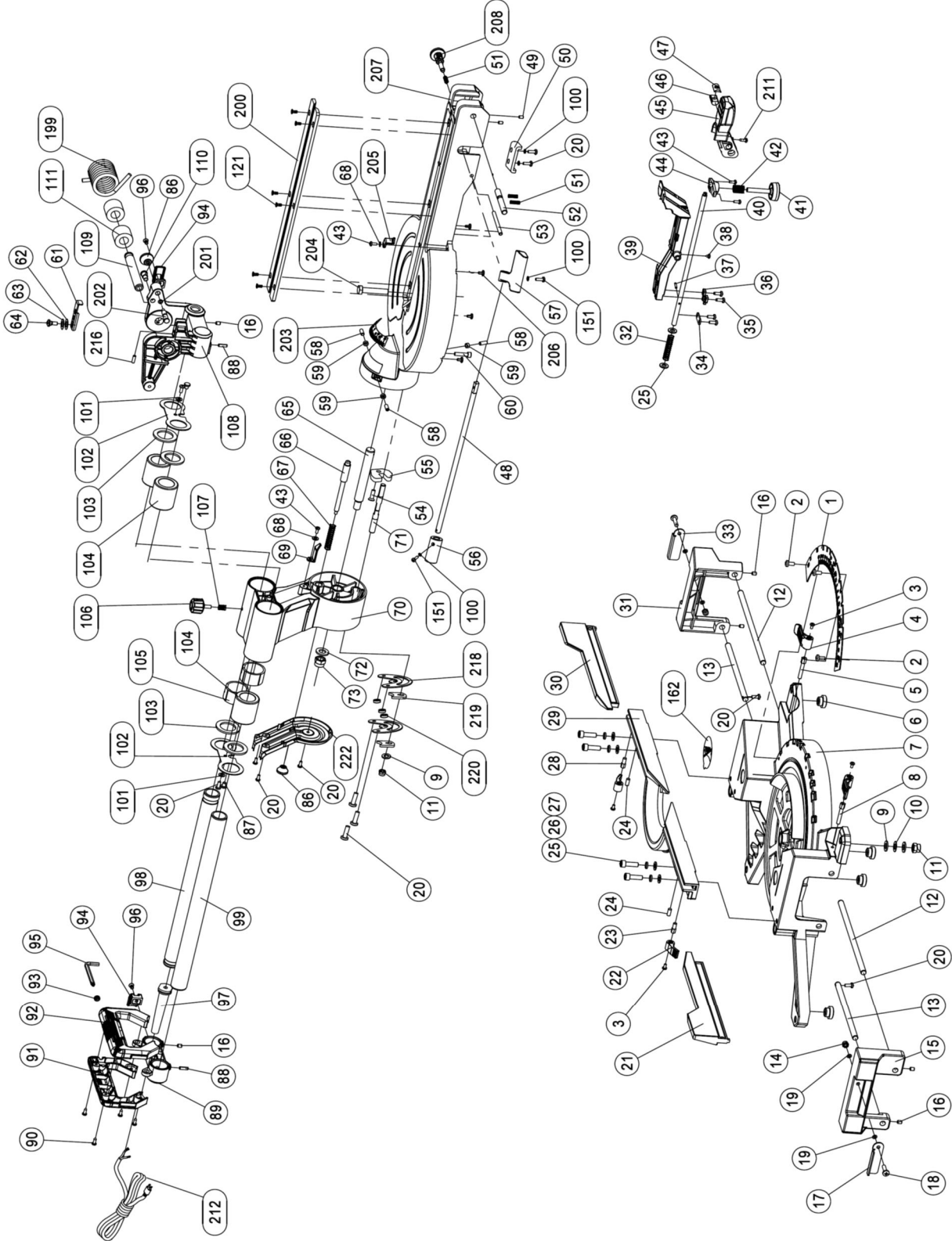

13.1.2 JMS-10X (#707210) – Miter Saw Assembly – Exploded View II

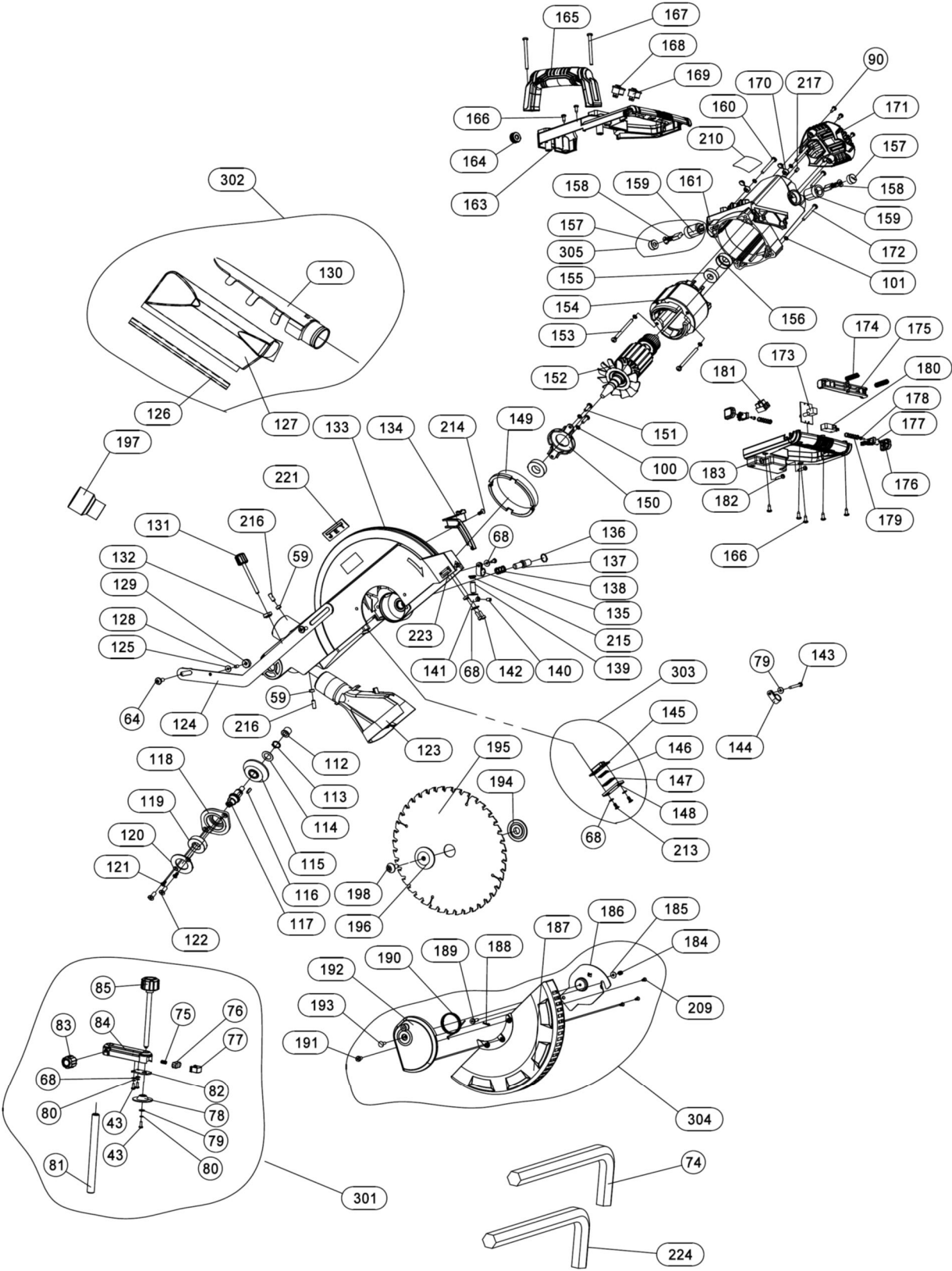

13.1.3 JMS-10X (#707210) – Miter Saw Assembly – Parts List

Index No	Part No	Description	Size	Qty
001	JMS10X-001	Miter Angle Scale		1
002	TS-2245122	Socket Head Button Screw	M5x12	3
003	TS-2284082	Pan Head Machine Screw	M4x8	4
004	JMS10X-004	Lock Handle		2
005	JMS10X-005	Lock Bolt (RH Threads)		1
006	JMS10X-006	Foot		4
007	JMS10X-007	Base		1
008	JMS10X-008	Lock Bolt (LH Threads)		1
009	TS-1550071	Flat Washer	10 mm	4
010	JAT450-31	Wave Washer	10 mm	1
011	TS-2342101	Hex Nut, Nylon Lock	M10	2
012	JMS10X-012	Extension Rod (Long)		2
013	JMS10X-013	Extension Rod (Short)		2
014	TS-1541021	Hex Nut, Nylon Lock	M6	2
015	JMS10X-015	Left Worktable		1
016	TS-1523011	Socket Set Screw	M6x6	7
017	JMS10X-017	Left Stop Plate		1
018	TS-2286202	Pan Head Machine Screw	M6x20	2
019	TS-1550041	Flat Washer	6 mm	4
020	TS-1533042	Pan Head Machine Screw	M5x12	9
021	JMS10X-021	Fence Extension, Left		1
022	JMS10X-022	Lock Handle		2
023	JMS10X-023	Lock Bolt (RH threads)		1
024	TS-1523051	Socket Set Screw	M6x16	2
025	TS-1550061	Flat Washer	8 mm	6
026	TS-2361081	Lock Washer	8 mm	4
027	TS-1504051	Socket Head Cap Screw	M8x25	4
028	JMS10X-028	Lock Bolt (LH threads)		1
029	JMS10X-029	Fence		1
030	JMS10X-030	Fence Extension, Right		1
031	JMS10X-031	Right Worktable		2
032	JMS10X-032	Spring		1
033	JMS10X-033	Right Stop Plate		1
034	JMS10X-034	Plate		1
035	JMS10X-035	Self-Tapping Screw	ST4.8x13 mm	4
036	JMS10X-036	Fixed Block		1
037	F012097	Roll Pin	3x16 mm	1
038	JMS10X-038	Self-Tapping Screw	ST4x8	1
039	JMS10X-039	Fixed Block		1
040	JMS10X-040	Locking Rod		1
041	JMS10X-041	Adjustable Foot		1
042	JMS10X-042	Spring		1
043	TS-1532042	Pan Head Machine Screw	M4x12	8
044	JMS10X-044	Support		1
045	JMS10X-045	Lock Handle		1
046	JMS10X-046	Adjust Pin		1
047	JMS10X-047	Locking Block		1
048	JMS10X-048	Locking Rod		1
049	TS-1522021	Socket Set Screw	M5x8	3
050	JMS10X-050	Stop Plate		1
051	JMS10X-051	Spring		1
052	JMS10X-052	Lock Axis		1
053	JMS10X-053	Locating Axis		1
054	TS-1513041	Socket Head Flat Screw	M5x20	1
055	JMS10X-055	Stop Plate		1
056	JMS10X-056	Sleeve		1
057	JMS10X-057	Lock Handle		1
058	TS-1523061	Socket Set Screw	M6x20	3
059	JMS10X-059	Washer		5
060	TS-1503061	Socket Head Cap Screw	M6x25	1

Index No	Part No	Description	Size	Qty
061	JMS10X-061	Stop Plate		1
062	F011908	Wave Washer	8 mm	1
063	JMS10X-063	Flat Washer		1
064	JMS10X-064	Screw	M6	3
065	JMS10X-065	Shaft		1
066	JMS10X-066	Pin		1
067	JMS10X-067	Spring		1
068	TS-1550021	Flat Washer	4 mm	11
069	JMS10X-069	Pointer		1
070	JMS10X-070	Support Arm		1
071	JMS10X-071	Lock Shaft		1
072	TS-2360121	Flat Washer	12 mm	1
073	TS-2342121	Hex Nut, Nylon Lock	M12	1
074	JMS10X-074	Hex Wrench	2.5mm	1
075	JMS10X-075	Spring		1
076	JMS10X-076	Locking Block		1
077	JMS10X-077	Button		1
078	JMS10X-078	Plate		1
079	JMS10X-079	Washer	4mm	2
080	TS-2361041	Lock Washer	4mm	7
081	JMS10X-081	Post		1
082	JMS10X-082	Plate		1
083	JMS10X-083	Knob		1
084	JMS10X-084	Clamp Support		1
085	JMS10X-085	Handle		1
086	JMS10X-086	Knob		1
087	JMS10X-087	Washer		2
088	JMS10X-088	Pin	5x14 mm	2
089	JMS10X-089	Sleeve		1
090	JMS10X-090	Self-Tapping Screw	ST4.2x13	8
091	JMS10X-091	Handle Left		1
092	JMS10X-092	Handle Right		1
093	JMS10X-093	Grommet		1
094	JMS10X-094	Cord Holder		1
095	JMS10X-095	Hex Wrench with Cross Point	6mm	1
096	TS-1513011	Socket Head Flat Screw	M5x10	2
097	JMS10X-097	Protective Sleeve		1
098	JMS10X-098	Slide Bar, Right		1
099	JMS10X-099	Slide Bar, Left		1
100	TS-2361051	Lock Washer	5 mm	6
101	TS-1550031	Flat Washer	5 mm	8
102	JMS10X-102	Bearing Plate		2
103	JMS10X-103	Felt		4
104	JMS10X-104	Bearing	LM254035	4
105	JMS10X-105	Bearing Sleeve		2
106	JMS10X-106	Knob		1
107	JMS10X-107	Spring		1
108	JMS10X-108	Support		1
109	JMS10X-109	Shaft		1
110	JMS10X-110	Screw		1
111	JMS10X-111	Sleeve		2
112	JMS10X-112	Bearing		1
113	F006042	C-Retaining Ring, Ext	14 mm	1
114	JMS10X-114	Washer		1
115	JMS10X-115	Gear		1
116	K-4412	Key, Dbl Rd Hd	4x4x12 mm	1
117	JMS10X-117	Arbor		1
118	JMS10X-118	Gear Cover		1
119	BB-6003ZZ	Bearing	6003-2RS	2
120	JMS10X-120	Plate		1
121	TS-1512011	Socket Head Flat Screw	M4x10	8

Index No	Part No	Description	Size	Qty
122	TS-1514021	Socket Head Flat Screw	M6x16	2
123	JMS10X-123	Dust Exhaust		1
124	JMS10X-124	Linkage Bar		1
125	JMS10X-125	Washer	6 mm	1
126	JMS10X-126	Clip		1
127	JMS10X-127	Dust Bag		1
128	JMS10X-128	Pin		1
129	JMS10X-129	Bearing	606-2RS	1
130	JMS10X-130	Plastic Frame		1
131	JMS10X-131	Knob		1
132	JMS10X-132	Nut		1
133	JMS10X-133	Saw Body		1
134	JMS10X-134	Support Piece		1
135	JMS10X-135	Cable Clip		1
136	JMS10X-136	Retaining Ring	Ø10.5 x 1	1
137	JMS10X-137	Pin		1
138	JMS10X-138	Spring		1
139	JMS10X-139	Laser Unit		2
140	TS-1523011	Socket Set Screw	M6x6	1
141	JMS10X-141	Laser Seat		1
142	TS-1501041	Socket Head Cap Screw	M4x12	2
143	JMS10X-143	Self-Tapping Screw	ST4.2x40 mm	1
144	JMS10X-144	Cable Clip		1
145	JMS10X-145	Light Box		1
146	JMS10X-146	LED Light		1
147	JMS10X-147	Seal		1
148	JMS10X-148	Lens		1
149	JMS10X-149	Deflector		1
150	JMS10X-150	Motor Plate		1
151	F001232	Pan Head Machine Screw	M5x16	2
152	JMS10X-152	Armature		1
153	F001231	Pan Head Machine Screw	M5-0.8x70	2
154	JMS10X-154	Stator		1
155	BB-6001ZZ	Ball Bearing	6001-2RS	1
156	JMS10X-156	Damping Ring		1
157	JMS10X-157	Cap		2
158	JMS10X-158	Carbon Brush		2
159	JMS10X-159	Brush Holder		2
160	F001232	Pan Head Machine Screw	M5-0.8x45	2
161	JMS10X-161	Motor Housing		1
162	JMS10X-162	Warning Label (Hands Clear Symbol)		2
163	JMS10X-163	Upper Handle		1
164	JMS10X-164	Grommet		1
165	JMS10X-165	Handle		1
166	JDP17-090	Self-Tapping Screw	ST4.2x16 mm	8
167	F001233	Pan Head Machine Screw	M5-0.8x60	2
168	JMS10X-168	Laser Switch	KCD-117	1
169	JMS10X-169	LED Light Switch	KCD-117	1
170	JMS10X-170	Screw Cap		2
171	JMS10X-171	Motor Cover		1
172	TS-2285352	Pan Head Machine Screw	M5x35	2
173	JMS10X-173	Controller Assembly		1
174	JMS10X-174	Spring		2
175	JMS10X-175	Trigger		1
176	JMS10X-176	Button		2
177	JMS10X-177	Button		2
178	JMS10X-178	Self-Tapping Screw	ST2.9x9.5	2
179	JMS10X-179	Spring		2
180	JMS10X-180	Trigger Switch WD01-1	18A, 127V, ~ 5E4	1
181	JMS10X-181	Terminal		1
182	JMS10X-182	Self-Tapping Screw	ST4.2x19 mm	2
183	JMS10X-183	Lower Handle		1

Index No	Part No	Description	Size	Qty
184	TS-1541011	Hex Nut, Nylon Lock	M5	1
185	TS-1550031	Flat Washer	5 mm	1
186	JMS10X-186	Fixed Plate		1
187	JMS10X-187	Blade Guard		1
188	JMS10X-188	Pin		1
189	JMS10X-189	Screw		1
190	JMS10X-190	Spring		1
191	JMS10X-191	Screw		1
192	JMS10X-192	Support Plate		1
193	PM2700-236	Carriage Bolt	M5x16	1
194	JMS10X-194	Inner Flange		1
195	JMS10X-195	Blade	10"x40Tx5/8" Arbor	1
196	JMS10X-196	Outer Flange		1
197	JMS10X-197	Adaptor		1
198	JMS10X-198	Screw (LH Threads)	M8x20 Left	1
199	JMS10X-199	Spring		1
200	JMS10X-200	Table Insert		2
201	JMS10X-201	O-Ring		1
202	JMS10X-202	Pin		2
203	JMS10X-203	Bevel Angle Scale		1
204	CL1640ZX-0153	Hex Cap Screw	M10x55	1
205	JMS10X-205	Pointer		1
206	JMS10X-206	Washer		4
207	JMS10X-207	Table		1
208	JMS10X-208	Pin		1
209	TS-1512011	Socket Head Flat Screw	M4x10	3
210	LM000391	ID Label, JMS-10X		1
211	JDR34-026	Self-Tapping Screw	ST4.2x9.5 mm	1
212	JMS10X-212	Power Cord	14AWG	1
213	2210-331	Self-Tapping Screw	M4x12	3
214	990805	Self-Tapping Screw	M4x10	1
215	JMS10X-215	Light Cover		1
216	TS-1523051	Socket Set Screw	M6x16	3
217	TS-1522021	Socket Set Screw	M5x8	1
218	JMS10X-218	Friction Pad		2
219	JMS10X-219	Washer		2
220	JMS10X-220	Sleeve		3
221	JET-92	JET Logo	92x38 mm	1
222	JMS10X-222	Rear Cover		1
223	LM000393	Warning Label, Laser		1
224	TS-152704	Hex Wrench	3 mm	1
301	JMS10X-301	Clamp Hold Down Assembly (#75~85,43,68)		1
302	JMS10X-302	Dust bag Assembly (#126,127,130)		1
303	JMS10X-303	LED Light Assembly (#145~148,213,68)		1
304	JMS10X-304	Blade Guard Assembly (#184~193, 209)		1
305	JMS10X-305	Carbon Brush Assembly (#157~159)		1
	LM000392	Warning Label, (not shown)		1

13.2.2 JMS-12X (#707212) – Miter Saw Assembly – Exploded View II

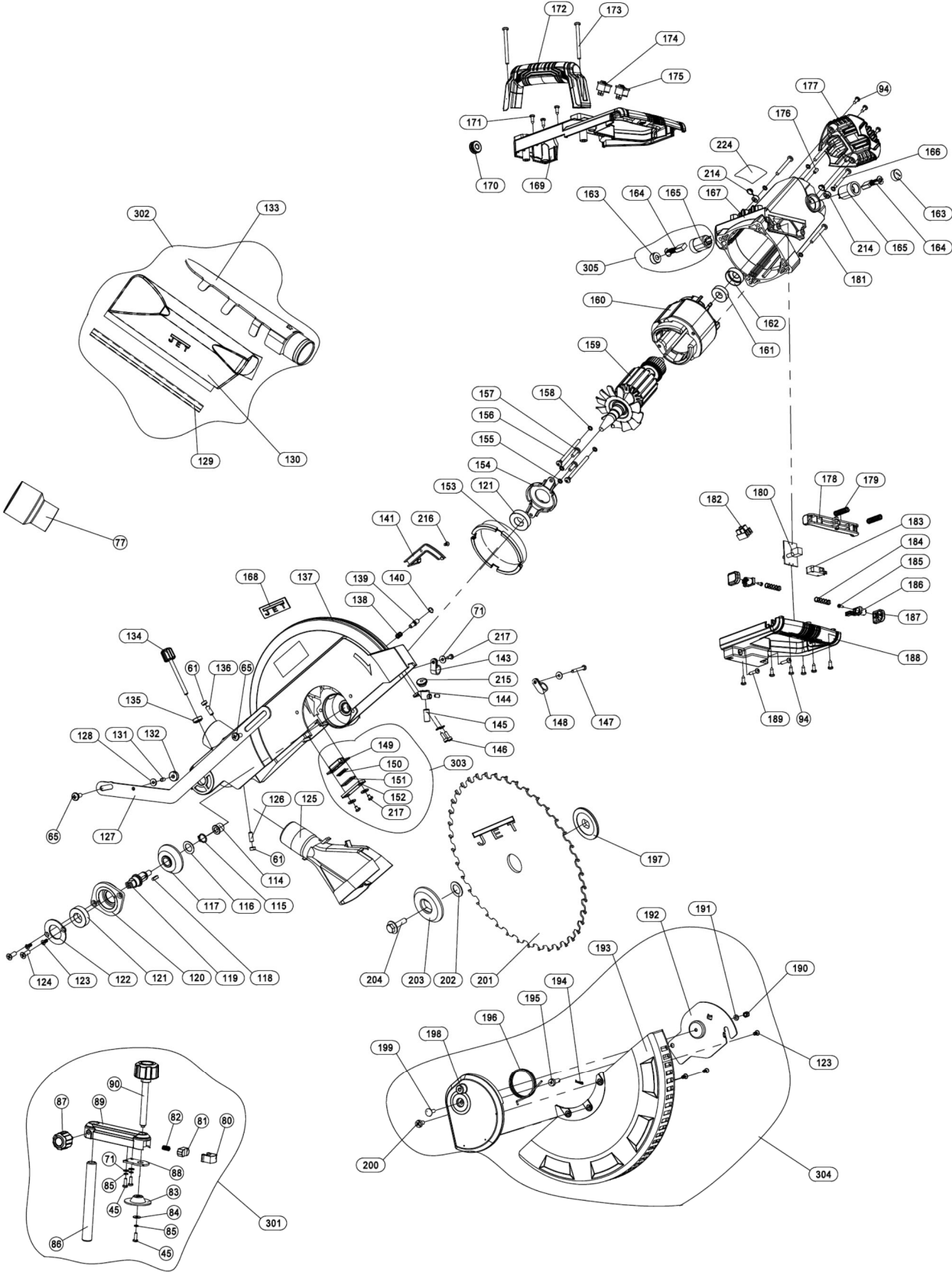

13.2.3 JMS-12X (#707212) – Miter Saw Assembly – Parts List

Index No	Part No	Description	Size	Qty
001	JMS12X-001	Miter Angle Scale		1
002	TS-2246122	Socket Head Button Screw	M6x12	3
003	TS-2284082	Pan Head Machine Screw	M4x8	4
004	JMS10X-004	Lock Handle		2
005	JMS12X-005	Lock Bolt (RH Threads)		1
006	JMS10X-006	Foot		4
007	JMS12X-007	Base		1
008	JMS12X-008	Lock Bolt (LH Threads)		1
009	TS-1550071	Flat Washer	10 mm	3
010	JMS10X-010	Wave Washer	10 mm	1
011	TS-2342101	Hex Nut, Nylon Lock	M10	2
012	JMS10X-012	Extension Rod (Long)		2
013	TS-1533042	Pan Head Machine Screw	M5x12	7
014	JMS10X-013	Extension Rod (Short)		2
015	TS-1541021	Hex Nut, Nylon Lock	M6	2
016	TS-2361061	Lock Washer	6 mm	2
017	TS-1550041	Flat Washer	6 mm	4
018	JMS12X-018	Left Worktable		1
019	TS-1523011	Socket Set Screw	M6x6	7
020	JMS10X-017	Left Stop Plate		1
021	TS-2286202	Pan Head Machine Screw	M6x20	2
022	JMS12X-022	Fence Extension, Left		1
023	JMS10X-022	Lock Handle		2
024	JMS10X-023	Lock Bolt (RH Threads)		1
025	TS-1523051	Socket Set Screw	M6x16	2
026	TS-1550061	Flat Washer	8 mm	4
027	TS-2361081	Lock Washer	8 mm	4
028	TS-1504051	Socket Head Cap Screw	M8x25	4
029	JMS10X-028	Lock Bolt (LH Threads)		1
030	JMS12X-030	Fence		1
031	JMS10X-162	Warning Label (Hands Clear Symbol)		2
032	JMS12X-032	Fence Extension, Right		1
033	JMS12X-033	Right Worktable		1
034	JMS10X-033	Right Stop Plate		1
035	TS-1550061	Flat Washer	8 mm	1
036	JMS12X-036	Spring		1
037	JMS12X-037	Locking Rod		1
038	JMS10X-037	Pin	3x16 mm	1
039	JMS12X-039	Locking Rod		1
040	JMS10X-036	Located Block		1
041	JMS10X-035	Self-Tapping Screw	ST4.8x13	4
042	JMS10X-051	Spring		3
043	JMS12X-043	Self-Tapping Screw	ST4.2x6.5	1
044	JMS12X-044	Fixed Block		1
045	TS-1532042	Pan Head Machine Screw	M4x12	8
046	JMS10X-045	Lock Handle		1
047	JMS10X-046	Adjust Pin		1
048	JMS10X-047	Locking Block		1
049	JMS10X-041	Adjustable Foot		1
050	JMS10X-042	Spring		1
051	JMS10X-044	Support		1
052	TS-1522021	Socket Set Screw	M5x8	3
053	JMS10X-074	Hex Wrench	2.5mm	1
054	JMS12X-054	Lock Axis		1
055	JMS10X-050	Stop Plate		1
056	JMS10X-056	Sleeve		1
057	JMS10X-057	Lock Handle		1
058	JMS12X-058	Locating Axis		1
059	JMS10X-034	Stop Plate		1

Index No	Part No	Description	Size	Qty
060	JMS10X-206	Washer		6
061	JMS10X-059	Locking Ring		5
062	TS-1523061	Socket Set Screw	M6x20	3
063	TS-1503051	Socket Head Cap Screw	M6x20	1
064	JMS12X-064	Stop Plate		1
065	JMS10X-064	Screw		3
066	JMS10X-063	Washer	8 mm	1
067	F011908	Wave Washer	8 mm	1
068	JMS12X-068	Shaft		1
069	JMS12X-069	Pin		1
070	JMS10X-067	Spring		1
071	TS-1550021	Flat Washer	4 mm	8
072	JMS10X-069	Pointer		1
073	JMS12X-073	Support Arm		1
074	JMS12X-074	Friction Pad		2
075	TS-2360121	Flat Washer	12 mm	1
076	TS-2342121	Hex Nut, Nylon Lock	M12	1
077	JMS10X-197	Adaptor		1
078	JMS10X-086	Knob		2
079	JMS10X-087	Washer		2
080	JMS10X-077	Button		1
081	JMS10X-076	Locking Block		1
082	JMS10X-075	Spring		1
083	JMS10X-078	Plate		1
084	JMS12X-084	Washer	4mm	2
085	TS-2361041	Lock Washer	4mm	3
086	JMS12X-086	Post		1
087	JMS10X-083	Knob		1
088	JMS10X-082	Plate		1
089	JMS10X-084	Clamp Support		1
090	JMS10X-085	Handle		1
091	F012104	Roll Pin	5x14 mm	2
092	JMS12X-092	Sleeve		1
093	JMS10X-212	Power Cord	14AWG	1
094	F011287	Self-Tapping Screw	ST4.2x13 mm	6
095	JMS12X-095	Handle Left		1
096	JMS12X-096	Handle Right		1
097	JMS10X-093	Grommet		1
098	JMS10X-094	Cord Holder		1
099	JMS10X-095	Hex Wrench with Cross Point	6mm	1
100	TS-1513011	Socket Head Flat Screw	M5x10	4
101	JMS12X-101	Protective Sleeve		1
102	JMS12X-102	Slide Bar, Right		1
103	JMS12X-103	Slide Bar, Left		1
104	JMS12X-104	Bearing Plate		2
105	JMS12X-105	Felt		4
106	JMS12X-106	Bearing	LM304550	4
107	JMS12X-107	Bearing Sleeve		2
108	JMS10X-107	Spring		1
109	JMS10X-106	Knob		1
110	JMS12X-110	Support		1
111	JMS12X-111	Shaft		1
112	JMS10X-110	Screw		1
113	JMS12X-113	Sleeve		1
114	JMS10X-112	Bearing		1
115	F006042	C-Retaining Ring, Ext	14 mm	1
116	JMS10X-114	Washer		1
117	JMS10X-115	Gear		1
118	K-4412	Key, Dbl Rd Hd	4x4x12 mm	1
119	JMS10X-117	Arbor		1
120	JMS10X-118	Gear Cover		1
121	BB-6003ZZ	Bearing	6003-2RS	2

Index No	Part No	Description	Size	Qty
122	JMS10X-120	Plate		1
123	TS-1512011	Socket Head Flat Screw	M4x10	5
124	TS-1514021	Socket Head Flat Screw	M6x16	2
125	JMS12X-125	Dust Exhaust		1
126	TS-1523071	Socket Set Screw	M6x25	1
127	JMS12X-127	Linkage Bar		1
128	JMS10X-125	Washer	6 mm	1
129	JMS10X-126	Clip		1
130	JMS10X-127	Dust Bag		1
131	JMS10X-128	Pin		1
132	JMS12X-132	Bearing	606-2RS	1
133	JMS10X-130	Plastic Parts		1
134	JMS12X-134	Knob		1
135	JMS10X-132	Nut		1
136	TS-1523051	Socket Set Screw	M6x16	2
137	JMS12X-137	Saw Body		1
138	JMS10X-138	Pin		1
139	JMS10X-137	Spring		1
140	JMS10X-136	Retaining Ring	Ø10.5x1 mm	1
141	JMS12X-141	Support Piece		1
142	TS-1512011	Socket Head Flat Screw	M4x10	6
143	JMS10X-135	Cable Clip		1
144	JMS10X-141	Laser Seat		1
145	JMS10X-139	Laser Unit		2
146	TS-1501041	Socket Head Cap Screw	M4x12	2
147	JMS12X-147	Self-Tapping Screw	ST4.2x40	1
148	JMS10X-144	Cable Clip		1
149	JMS10X-145	Light Box		1
150	JMS10X-146	LED Light		1
151	JMS10X-147	Seal		1
152	JMS10X-148	Lens		1
153	JMS10X-149	Deflector		1
154	JMS10X-150	Motor Plate		1
155	TS-2361051	Lock Washer	5 mm	5
156	F001231	Pan Head Machine Screw	M5-0.8x70	2
157	TS-1533052	Pan Head Machine Screw	M5x16	8
158	TS-1550031	Flat Washer	5 mm	6
159	JMS12X-159	Armature		1
160	JMS12X-160	Stator		1
161	BB-6001ZZ	Ball Bearing	6001-2RS	1
162	JMS10X-156	Damping Ring		1
163	JMS10X-157	Cap		2
164	JMS10X-158	Carbon Brush		2
165	JMS10X-159	Brush Holder		2
166	F001232	Pan Head Machine Screw	M5-0.8x45	2
167	JMS10X-161	Motor Housing		1
168	JET-92	JET Logo	92x38mm	1
169	JMS12X-169	Upper Handle		1
170	JMS10X-164	Grommet		1
171	JDP17-090	Self-Tapping Screw	ST4.2x16 mm	8
172	JMS10X-165	Handle		1
173	F001233	Pan Head Machine Screw	M5-0.8x60	2
174	JMS10X-168	Laser Switch	KCD-117	1
175	JMS10X-169	LED Light Switch	KCD-117	1
176	TS-1522021	Socket Set Screw	M5x8	1
177	JMS10X-171	Motor Cover		1
178	JMS10X-175	Trigger		1
179	JMS10X-174	Spring		2
180	JMS10X-173	Controller Assembly		1
181	TS-2285352	Pan Head Machine Screw	M5x35	2
182	JMS10X-181	Terminal		1
183	JMS10X-180	Trigger Switch WD01-1	18A, 127V, ~ 5E4	1

Index No	Part No	Description	Size	Qty
184	JMS10X-179	Spring		2
185	JMS12X-185	Self-Tapping Screw	ST2.9x9.5 mm	2
186	JMS10X-177	Button		2
187	JMS10X-176	Button		2
188	JMS12X-188	Lower Handle		1
189	JMS10X-182	Self-Tapping Screw	ST4.2x19 mm	2
190	TS-1541011	Hex Nut, Nylon Lock	M5	1
191	TS-1550031	Flat Washer	5 mm	1
192	JMS10X-186	Fixed Plate		1
193	JMS12X-193	Blade Guard		1
194	JMS10X-188	Pin		1
195	JMS10X-189	Screw		1
196	JMS10X-190	Spring		1
197	JMS10X-194	Inner Flange		1
198	JMS12X-198	Support Plate		1
199	PM2700-236	Carriage Bolt	M5x16	1
200	JMS10X-200	Screw		1
201	JMS12X-201	Saw Blade	12"x48Tx1" Arbor	1
202	JMS12X-202	Reducer	5/8" x1"x 0.11"	1
203	JMS10X-196	Outer Flange		1
204	JMS10X-198	Screw (LH Threads)	M8x20 Left	1
205	JMS12X-205	Spring		1
206	JMS10X-201	O Ring	Ø8xØ1.9 mm	1
207	JMS10X-202	Pin		2
208	JMS12X-208	Bevel Angle Scale		1
209	JMS12X-209	Hex Cap Screw	M10x50	1
210	JMS12X-200	Table Insert		2
211	JMS10X-205	Pointer		1
212	JMS12X-212	Table		1
213	JMS10X-208	Pin		1
214	JMS10X-170	Screw Cap		2
215	JMS10X-215	Light Cover		1
216	990805	Self-Tapping Screw	M4x10	1
217	2210-331	Self-Tapping Screw	M4x12	3
218	JMS12X-218	Washer		2
219	JMS10X-220	Sleeve		3
220	JMS12X-220	Shaft		1
221	TS-1522061	Socket Set Screw	M5x20	1
222	JMS10X-055	Stop Plate		1
223	JMS12X-223	Rear Cover		1
224	LM000394	ID Label, JMS-12X		1
225	LM000393	Warning Label, Laser		1
226	TS-152704	Hex Wrench	3 mm	1
301	JMS12X-301	Clamp Hold Down Assembly (#81~90,45,71)		1
302	JMS12X-302	Dust bag Assembly (#129,130,133)		1
303	JMS12X-303	LED Light Assembly (#149~152, 217)		1
304	JMS12X-304	Blade Guard Assembly (#190~200,123)		1
305	JMS12X-305	Carbon Brush Assembly (#163~165)		1
	LM000392	Warning Label, (not shown)		1

14.0 Electrical Connections – JMS-10X,12X

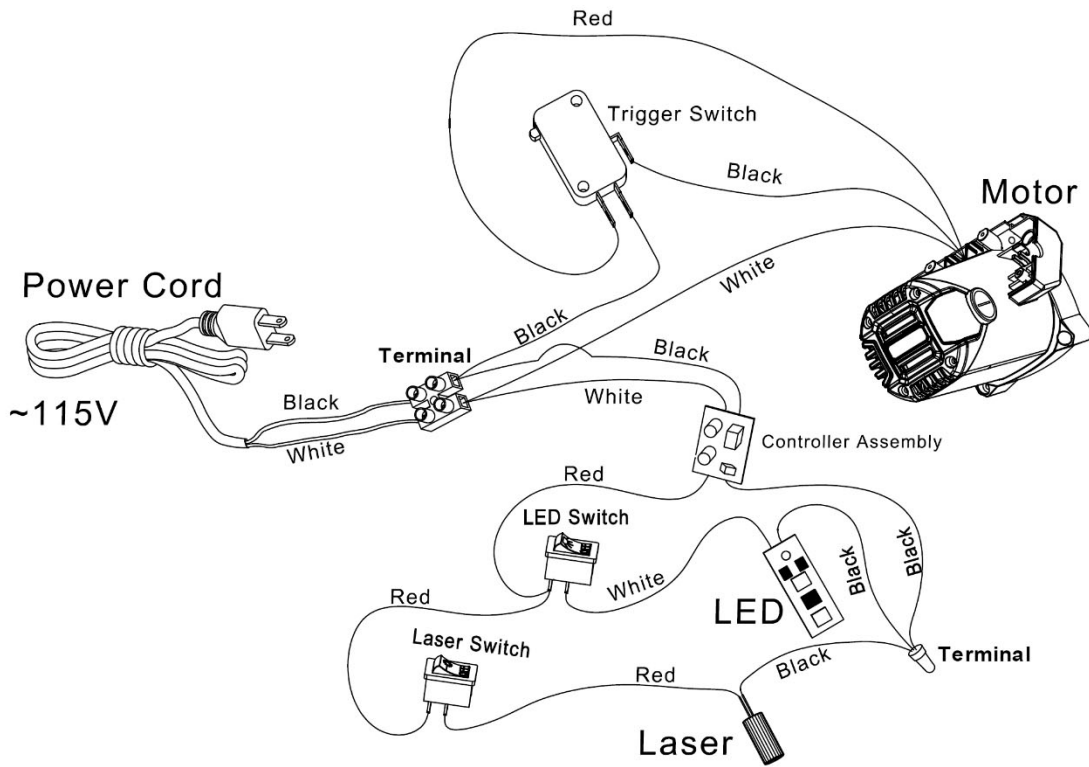
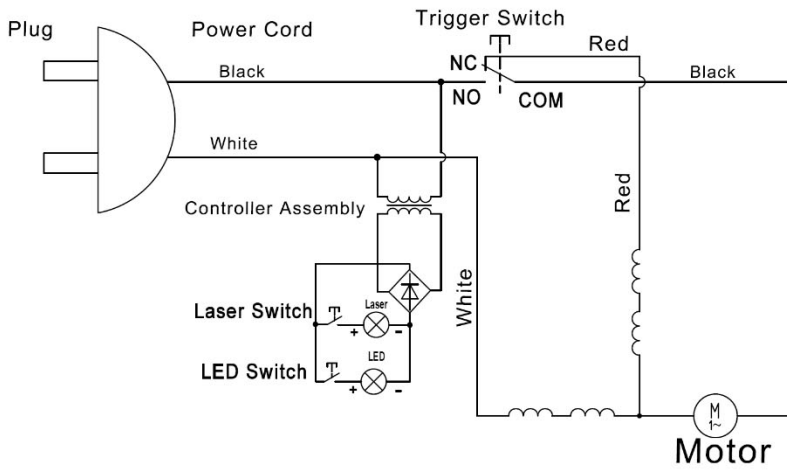

15.0 Warranty and service

JET® warrants every product it sells against manufacturers' defects. If one of our tools needs service or repair, please contact Technical Service by calling 1-800-274-6846, 8AM to 5PM CST, Monday through Friday.

Warranty Period

The general warranty lasts for the time period specified in the literature included with your product or on the official JET branded website.

- JET products carry a limited warranty which varies in duration based upon the product. (See chart below)
- Accessories carry a limited warranty of one year from the date of receipt.
- Consumable items are defined as expendable parts or accessories expected to become inoperable within a reasonable amount of use and are covered by a 90 day limited warranty against manufacturer's defects.

Who is Covered

This warranty covers only the initial purchaser of the product from the date of delivery.

What is Covered

This warranty covers any defects in workmanship or materials subject to the limitations stated below. This warranty does not cover failures due directly or indirectly to misuse, abuse, negligence or accidents, normal wear-and-tear, improper repair, alterations or lack of maintenance. JET woodworking machinery is designed to be used with Wood. Use of these machines in the processing of metal, plastics, or other materials outside recommended guidelines may void the warranty. The exceptions are acrylics and other natural items that are made specifically for wood turning.

Warranty Limitations

Woodworking products with a Five Year Warranty that are used for commercial or industrial purposes default to a Two Year Warranty. Please contact Technical Service at 1-800-274-6846 for further clarification.

How to Get Technical Support

Please contact Technical Service by calling 1-800-274-6846. **Please note that you will be asked to provide proof of initial purchase when calling.** If a product requires further inspection, the Technical Service representative will explain and assist with any additional action needed. JET has Authorized Service Centers located throughout the United States. For the name of an Authorized Service Center in your area call 1-800-274-6846 or use the Service Center Locator on the JET website.

More Information

JET is constantly adding new products. For complete, up-to-date product information, check with your local distributor or visit the JET website.

How State Law Applies

This warranty gives you specific legal rights, subject to applicable state law.

Limitations on This Warranty

JET LIMITS ALL IMPLIED WARRANTIES TO THE PERIOD OF THE LIMITED WARRANTY FOR EACH PRODUCT. EXCEPT AS STATED HEREIN, ANY IMPLIED WARRANTIES OF MERCHANTABILITY AND FITNESS FOR A PARTICULAR PURPOSE ARE EXCLUDED. SOME STATES DO NOT ALLOW LIMITATIONS ON HOW LONG AN IMPLIED WARRANTY LASTS, SO THE ABOVE LIMITATION MAY NOT APPLY TO YOU.

JET SHALL IN NO EVENT BE LIABLE FOR DEATH, INJURIES TO PERSONS OR PROPERTY, OR FOR INCIDENTAL, CONTINGENT, SPECIAL, OR CONSEQUENTIAL DAMAGES ARISING FROM THE USE OF OUR PRODUCTS. SOME STATES DO NOT ALLOW THE EXCLUSION OR LIMITATION OF INCIDENTAL OR CONSEQUENTIAL DAMAGES, SO THE ABOVE LIMITATION OR EXCLUSION MAY NOT APPLY TO YOU.

JET sells through distributors only. The specifications listed in JET printed materials and on official JET website are given as general information and are not binding. JET reserves the right to effect at any time, without prior notice, those alterations to parts, fittings, and accessory equipment which they may deem necessary for any reason whatsoever. JET® branded products are not sold in Canada by JPW Industries, Inc.

Product Listing with Warranty Period

90 Days – Parts; Consumable items
1 Year – Motors; Machine Accessories; Air Tool Accessories
1 Year Wear and Tear – Air Tools
2 Year – Metalworking Machinery; Electric Hoists, Electric Hoist Accessories; Woodworking Machinery used for industrial or commercial purposes
3 Year – Woodworking Bench Top Machinery
5 Year – Woodworking Machinery
Limited Lifetime – JET Parallel clamps; VOLT Series Electric Hoists; Manual Hoists; Manual Hoist Accessories; Shop Tools; Warehouse & Dock products; Hand Tools: Air Tools

NOTE: JET is a division of JPW Industries, Inc. References in this document to JET also apply to JPW Industries, Inc., or any of its successors in interest to the JET brand.