

POWERMATIC®

Operating Instructions and Parts Manual Sliding Table for PM2000B and PM3000B Table Saws



Powermatic
427 New Sanford Road
LaVergne, Tennessee 37086
Ph.: 800-274-6848
www.powermatic.com

Part No. M-1794860
Edition 1 08/2018
Copyright © 2018 Powermatic



1.0 IMPORTANT SAFETY INSTRUCTIONS

READ ALL INSTRUCTIONS BEFORE USING THIS MACHINE.

WARNING – To reduce risk of injury:

1. Read and understand the entire owner's manual before attempting assembly or operation.
2. Read and understand the warnings posted on the machine and in this manual. Failure to comply with all of these warnings may cause serious injury.
3. Replace the warning labels if they become obscured or removed.
4. **WARNING:** This product can expose you to chemicals which are known to the State of California to cause cancer and birth defects or other reproductive harm. For more information go to <http://www.p65warnings.ca.gov>.
5. **WARNING:** Drilling, sawing, sanding or machining wood products generates wood dust and other substances known to the State of California to cause cancer. Avoid inhaling dust generated from wood products or use a dust mask or other safeguards for personal protection.
6. Wood products emit chemicals known to the State of California to cause birth defects or other reproductive harm. For more information go to <http://www.p65warnings.ca.gov/wood>.
7. This table saw accessory is designed and intended for use by properly trained and experienced personnel only. If you are not familiar with the proper and safe operation of a table saw, do not use until proper training and knowledge have been obtained.
8. Do not use this table saw accessory for other than its intended use. If used for other purposes, Powermatic disclaims any real or implied warranty and holds itself harmless from any injury that may result from that use.
9. Always wear approved safety glasses or face shield while using the table saw. Everyday eyeglasses only have impact resistant lenses; they are not safety glasses.
10. Before operating the table saw, remove tie, rings, watches and other jewelry, and roll sleeves up past the elbows. Do not wear loose clothing. Confine long hair. Non-slip footwear or anti-skid floor strips are recommended. Do not wear gloves.
11. Wear ear protectors (plugs or muffs) during extended periods of operation.
12. Do not operate this machine while tired or under the influence of drugs, alcohol or any medication.
13. Make certain the machine is properly grounded.
14. Make all machine adjustments or maintenance with the machine unplugged from the power source. A machine under repair should be RED TAGGED to show it must not be used until maintenance is complete.
15. Remove adjusting keys and wrenches. Form a habit of checking to see that keys and adjusting wrenches are removed from the machine before turning it on.
16. Keep safety guards in place at all times when the machine is in use. If removed for maintenance purposes, use extreme caution and replace the guards immediately.
17. Check damaged parts. Before further use of the machine, a guard or other part that is damaged should be carefully checked to determine that it will operate properly and perform its intended function. Check for alignment of moving parts, binding of moving parts, breakage of parts, mounting and any other conditions that may affect its operation. A guard or other part that is damaged should be properly repaired or replaced.
18. Provide for adequate space surrounding work area and non-glare, overhead lighting.
19. Keep the floor around the machine clean and free of scrap material, oil and grease.
20. Keep visitors a safe distance from the work area. Keep children away.
21. Make your workshop child proof with padlocks, master switches or by removing safety keys.
22. Give your work undivided attention. Looking around, carrying on a conversation and "horse-play" are careless acts that can result in serious injury.
23. Maintain a balanced stance at all times so that you do not fall or lean against the blade or other moving parts. Do not overreach or use excessive force to perform any machine operation.
24. Use the right tool at the correct speed and feed rate. Do not force a tool or attachment to do a job for which it was not designed. The right tool will do the job better and safer.
25. Use recommended accessories; improper accessories may be hazardous.
26. Maintain tools with care. Keep blade sharp and clean for the best and safest performance.

Follow instructions for lubricating and changing accessories.

27. Check the saw blade for cracks or missing teeth. Do not use a cracked or dull blade or one with missing teeth or improper set. Make sure the blade is securely locked on the arbor.
28. Keep hands clear of the blade area. Do not reach past the blade to clear parts or scrap with the saw blade running. Never saw freehand. Avoid awkward operations and hand positions where a sudden slip could cause your hand to contact the blade.
29. Do not attempt to saw boards with loose knots or with nails or other foreign material, on its surface. Do not attempt to saw twisted, warped or bowed stock unless one edge has been jointed for guiding purposes prior to sawing. Excessively warped stock should not be used.
30. Do not attempt to saw long or wide boards unsupported where spring or weight could cause the board to shift position.
31. Always use the riving knife, blade guard, push stick and other safety devices for all operations where they can be used.
32. Be sure the saw blade rotates clockwise when viewed from the motor side (left side) of the machine.
33. Turn off the machine before cleaning. Use a brush or compressed air to remove chips or debris — do not use bare hands.
34. Do not stand on the machine. Serious injury could occur if the machine tips over.
35. Never leave the machine running unattended. Turn the power off and do not leave the machine until it comes to a complete stop.
36. Remove loose items and unnecessary work pieces from the area before starting the machine.
37. Blade should have minimum exposure during cuts. Adjust blade to approximately 1/8" inch above surface of workpiece.

1.1 Kickback

The most common accidents among table saw users, according to statistics, can be linked to kickback, the high-speed expulsion of material from the table that can strike the operator. Kickback can also result in the operator's hands being pulled into the blade.

Kickback Prevention

Tips to avoid the most common causes of kickback:

- Make sure the riving knife is always aligned with the blade. A workpiece can bind or stop the flow of the cut if the riving knife is misaligned, and result in kickback.
- Use a riving knife during every cut. The riving knife maintains the kerf in the workpiece, which will reduce the chance of kickback.
- Never attempt freehand cuts. The workpiece must be fed parallel to the blade, otherwise kickback will likely occur. Always use the fence or miter gauge to support the workpiece.
- Make sure that rip fence is parallel to blade. If not, the chances of kickback are very high. Take the time to check and adjust the rip fence.
- Feed cuts through to completion. Anytime you stop feeding a workpiece that is in the middle of a cut, the chance of binding, resulting in kickback, is greatly increased.

Tips for Kickback Protection

Kickback can happen even if precautions are taken to prevent it. Listed below are some tips to protect you if kickback *does* occur:

- Stand to the side of the blade when cutting. An ejected workpiece usually travels directly in front of the blade.
- Wear safety glasses or a face shield. Your eyes and face are the most vulnerable part of your body.
- Never place your hand behind the blade. If kickback occurs, your hand will be pulled into the blade.
- Use a push stick to keep your hands farther away from the moving blade. If a kickback occurs, the push stick will most likely take the damage that your hand would have received.

Familiarize yourself with the following safety notices used in this manual:

⚠CAUTION This means that if precautions are not heeded, it may result in minor injury and/or possible machine damage.

⚠WARNING This means that if precautions are not heeded, it may result in serious or possibly fatal injury.

2.0 About this manual

This manual is provided by Powermatic covering the safe operation and maintenance procedures for a Powermatic Sliding Table. This manual contains instructions on installation, safety precautions, general operating procedures, maintenance instructions and parts breakdown. Your sliding table has been designed and constructed to provide consistent, long-term operation if used in accordance with the instructions set forth in this document.

If there are questions or comments, please contact your local supplier or Powermatic. Powermatic can also be reached at our web site: www.powermatic.com.

Retain this manual for future reference. If the machine transfers ownership, the manual should accompany it.

Register your product using the mail-in card provided, or register online:

<http://www.powermatic.com/us/en/service-and-support/product-registration/>

⚠WARNING **Read and understand the entire contents of this manual before attempting assembly or operation! Failure to comply may cause serious injury!**

3.0 Table of contents

Section	Page
1.0 IMPORTANT SAFETY INSTRUCTIONS	2
1.1 Kickback	3
2.0 About this manual	4
3.0 Table of contents.....	5
4.0 Specifications for Powermatic Sliding Table	6
5.0 Features and terminology	7
6.0 Unpacking	8
6.1 Shipping contents.....	8
7.0 Setup and assembly.....	10
7.1 Tools required for assembly	10
7.2 Preparation.....	10
7.3 Leg and bracket assemblies.....	10
7.4 Rail assembly	11
7.5 Linkages and outer rail	12
7.6 Table installation	12
7.7 Angle adjusting rail installation	14
7.8 Fence installation	15
7.9 Flip stop	16
7.10 Assembly completion	16
8.0 Additional alignments	16
8.1 Leveling sliding table	16
8.2 Table-to-blade parallelism	16
8.3 Fence-to-blade squareness.....	17
8.4 Fence scale and flip stop.....	18
8.5 Capacity adjustment.....	19
9.0 Operations.....	19
9.1 Fence position and capacities	19
9.2 Cutting angles	19
9.3 General operating procedures.....	19
10.0 User-maintenance.....	20
10.1 Additional servicing	20
11.0 Replacement Parts.....	20
11.1.1 Table Assembly – Exploded View	21
11.1.2 Table Assembly – Parts List.....	22
11.2.1 Rail Assembly – Exploded View	24
11.2.2 Rail Assembly – Parts List.....	25
12.0 Warranty and Service.....	26

4.0 Specifications for Powermatic Sliding Table

Model number		PMST-48
Stock number		1794860K
Capacities		
Rip capacity ¹	Fence in front position	39 in. (991mm)
	Fence in rear position	41 in. (1041mm) – panel clears blade 49 in. (1245mm) – panel does not clear blade
Crosscut fence length		56-1/2 in. (1435mm)
Crosscut fence length with extension		91 in. (2314mm)
Table travel		62-1/2 in. (1587mm)
Miter angle range		0 to 50 deg.
Miter angle hard stops (deg.)		15, 22.5, 30, 45, 50, 90
Dimensions		
Shipping carton #1 (Rails, #1794860R) LxWxH		87-13/16 x 11 x 5-1/8 in. (223 x 28 x 13 cm)
Shipping carton #2 (Table, #1794860T) LxWxH		37 x 33-7/8 x 9-7/16 in. (94 x 86 x 24 cm)
Main materials		
Main frame, table, mounting brackets, legs		Steel
Crosscut fence		Extruded aluminum
Miter fence		Extruded aluminum and steel
Locking handles		Plastic
Table guides		Sealed ball bearings
Weights		
Net weight assembled (approx.)		143 lbs. (65 kg)
Shipping weight (approx.)	Carton #1 (Rails, #1794860R)	71 lbs. (32 kg)
	Carton #2 (Table, #1794860T)	84 lbs. (38 kg)

Table 1

¹ Based upon installation on PM2000B table saw with all four screws used in adjustment plate. Dimension may vary based upon saw model and/or adjustment plate position. See sect. 8.5 for details.

L=length, W=width, H=height

The specifications in this manual were current at time of publication, but because of our policy of continuous improvement, Powermatic reserves the right to change specifications at any time and without prior notice, without incurring obligations.

5.0 Features and terminology

These major components of the Sliding Table are referenced throughout the manual.

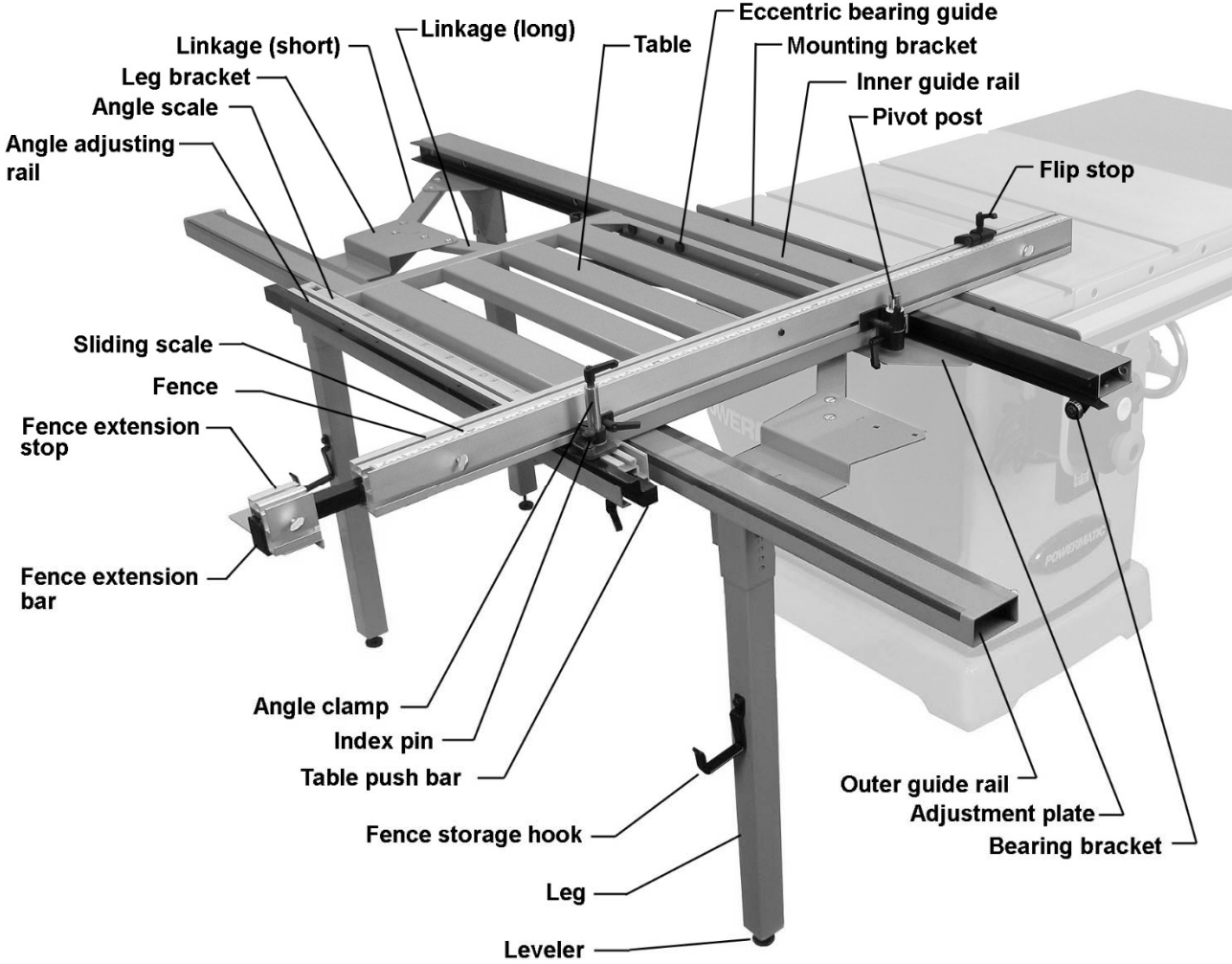

Figure 5-1: features and terminology

⚠WARNING Read and understand the entire contents of this manual before attempting set-up or operation.

⚠WARNING Read and understand all instructions and safety information that accompanied your table saw before installing or operating this sliding table. Failure to comply may cause serious injury.

6.0 Unpacking

Open boxes and check for shipping damage. Report any damage immediately to your distributor and shipping agent. Do not discard any shipping material until Sliding Table is installed and functioning properly.

Compare contents of your boxes with the following parts list to make sure all parts are intact. Any missing parts should be reported to your distributor.

6.1 Shipping contents

See Figures 6-1 and 6-2.

Box #1 – (1794860R, Rails):

- 1 Inner guide rail – **A**
- 1 Outer guide rail – **B**
- 1 Angle adjusting rail – **C**
- 1 Fence – **D**
- 1 Mounting bracket – **E**
- 1 Linkage, long – **F**

Box #2 – (1794860T, Table):

- 3 Legs – **G**
- 2 Left leg brackets – **H**
- 1 Right leg bracket – **I**
- 2 Linkage, short – **J**
- 1 Fence extension stop – **K**
- 1 Adjustment plate – **L**
- 1 Table – **M**
- 2 T-handle hex wrenches, 5mm and 6mm – **N**
- 1 Horizontal bearing bracket – **O**
- 2 Vertical bearing brackets – **P**
- 1 Fence pivot post – **Q**
- 1 T-nut – **R**
- 1 Locking handle – **S**
- 1 Angle clamp – **T**
- 1 Flip stop – **U**
- 1 Operating Instructions and Parts Manual
- 1 Product registration card
- 4 Hardware bags

Hardware bag 1:

- 2 Storage hooks – **HB10**
- 11 Flat washers 8mm – **HB11**
- 8 Hex cap screws M8x16 – **HB12**
- 3 Hex nuts M8 – **HB13**
- 3 Levelers – **HB14**

Hardware bag 2

- 12 Hex cap screws M8x16 – **HB20**
- 4 Socket hd cap screws M8x12 – **HB21**
- 16 Flat washers 8mm – **HB22**
- 3 Hex cap screws M10x20 – **HB23**
- 3 Flat washers 10mm – **HB24**

Hardware bag 3

- 12 Carriage bolts M8x16 – **HB30**
- 12 Flat washers 8mm – **HB31**
- 12 Cap nuts M8 – **HB32**

Hardware bag 4

- 2 Locking handles – **HB40**
- 2 Phillips pan head screws M4x12 – **HB41**
- 2 Flat washers 4mm – **HB42**
- 2 Nylon stop ring – **HB43**
- 2 Thumb screws – **HB44**

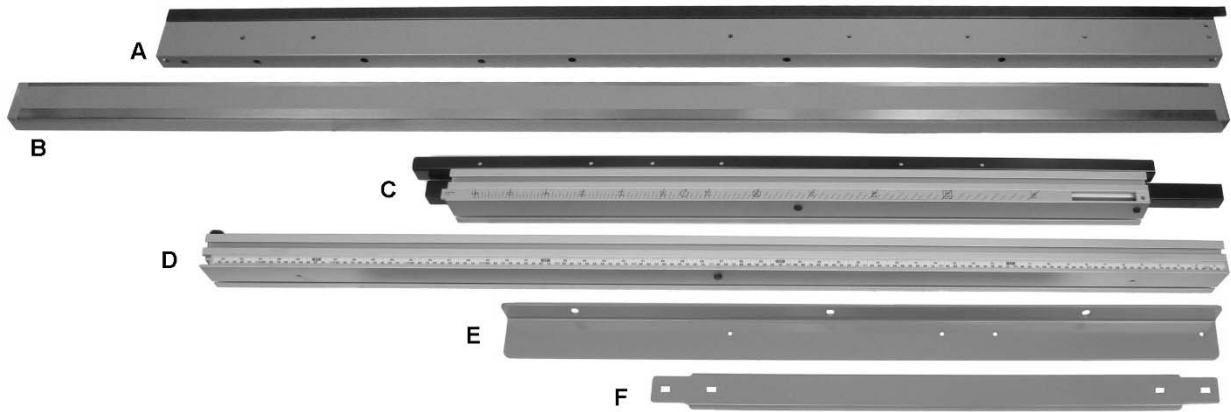

Figure 6-1: Box #1 contents (p/n 1794860R)

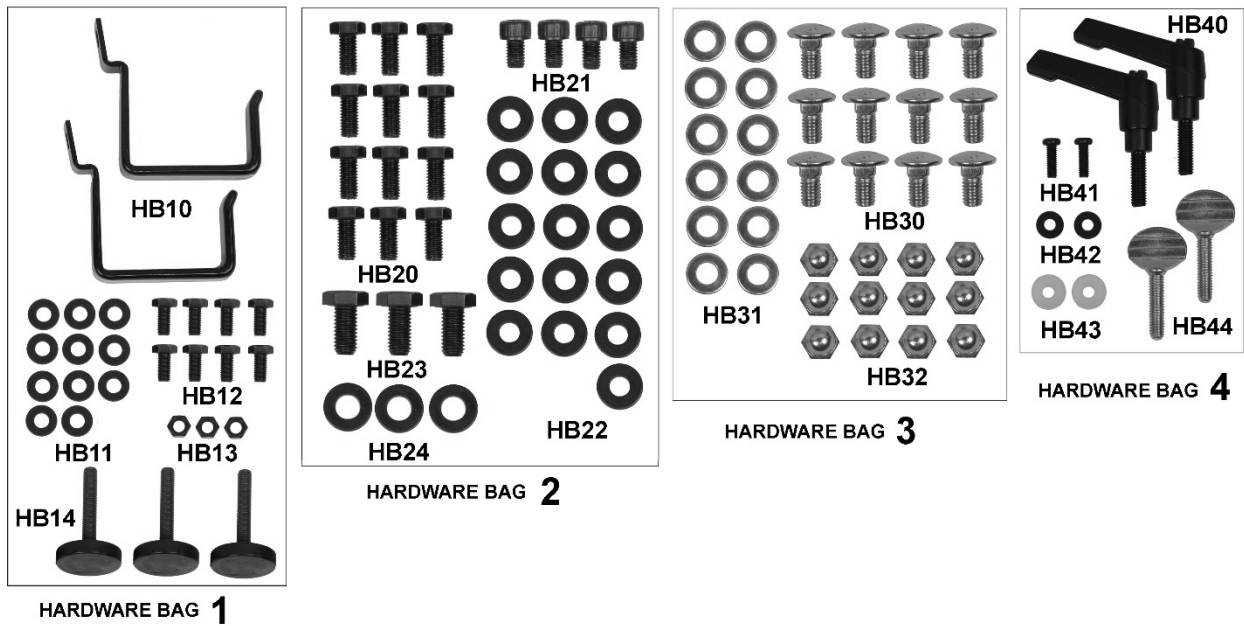
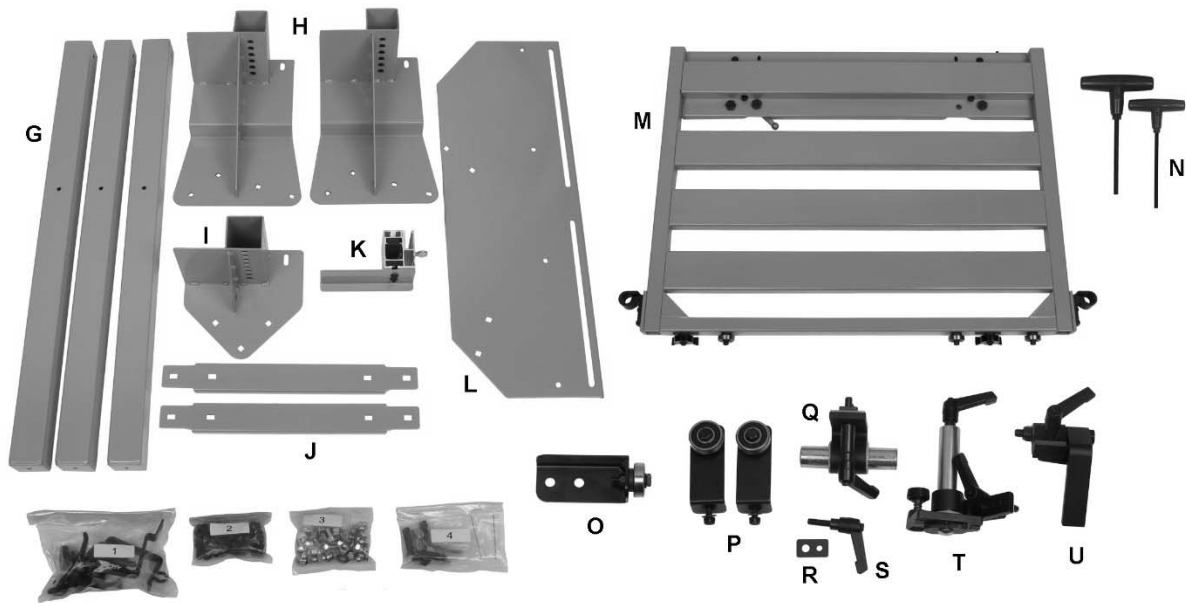

Figure 6-2: Box #2 contents (p/n 1794860T)
Not to scale

7.0 Setup and assembly

⚠WARNING Disconnect your table saw from power source (unplug) before installing Sliding Table.

IMPORTANT: Do not rush assembly of the Sliding Table; careful setup from the beginning will reward the user with accurate cuts and trouble-free operation. Powermatic recommends allowing 6 to 7 hours for complete installation and alignments.

The following instructions are for installing the Sliding Table on a Powermatic PM2000B or PM3000B Table Saw. If installing on a different table saw, modifications and/or additional tools may be needed.

7.1 Tools required for assembly

T-handle hex wrenches, 5/6mm – *provided*
Open end wrenches, 10/12/13/17mm *
Straight edge
Level
Machinist square
Tape measure or similar scale
Screwdrivers: flat blade and cross-point (Phillips)
Cardboard or wood shims, approx. 1/8-inch thick

* A ratchet wrench with sockets will speed assembly time.

7.2 Preparation

1. Position your Powermatic table saw in its final location, with sufficient space on all sides for operation, loading and off-loading of stock, and maintenance. Disengage caster system (settle table saw to floor).

IMPORTANT: It is recommended the sliding table be left in place after setup and adjustments. If it is removed and reinstalled, realignments may be needed.

2. Remove left extension wing from table saw.
3. Remove the on/off switch from the guide tube.
4. Remove guide tube, and front and rear rails, and install them farther to the right so that they do not extend past left end of saw table. The Powermatic rail system has additional holes to accommodate this shift, without the need for drilling.
5. Remove motor cover; it can be reinstalled after sliding table is in place.
6. Check that saw table is level with floor. If needed, use metal shims beneath saw cabinet or other means to make level.

7.3 Leg and bracket assemblies

Use **HARDWARE BAG 1**

1. Install leveler (HB14) with hex nut (HB13) and washer (HB11) into threaded hole on each leg. See Figure 7-1. The hex nut is tightened against the leg to secure setting. Leave about 1-inch protrusion as shown; final adjustment will be made later.
2. Install a leg into each bracket (H and I, Figure 7-1). For the Powermatic saw, insert screw through second hole (see inset, Figure 7-1); this can be adjusted later if needed.

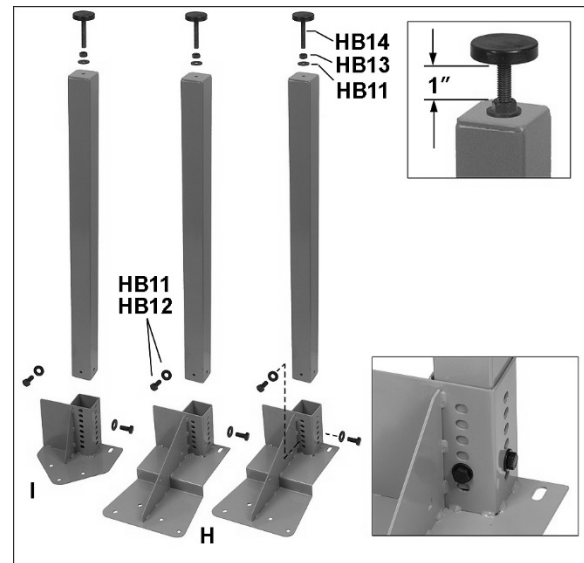

Figure 7-1

3. Attach storage hooks (HB10) onto the two left leg bracket assemblies. See Figure 7-2. Position hook as shown so that it will be correct when leg is turned upright. Tighten screw.

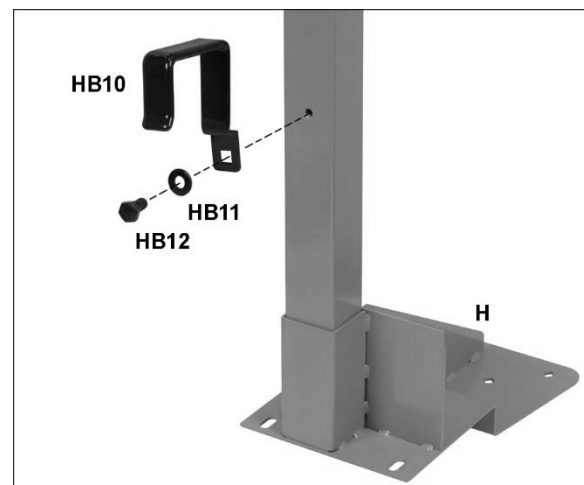

Figure 7-2

7.4 Rail assembly

Use HARDWARE BAG 2

1. Install mounting bracket (E, Figure 7-3) to saw table, as shown. Position bracket about 1/8-inch from top edge of table (see inset, Figure 7-3); this may be adjusted later. Tighten screws.
2. Install adjustment plate (L, Figure 7-3) to the bracket, using fasteners shown.

NOTE: Use all four screws in the adjustment plate for initial setup. Cut capacity can be modified later by removing one or two of the screws and shifting the plate with the entire sliding table assembly. **At least two screws must remain in the adjustment plate during operation.** See sect. 8.5 for details.

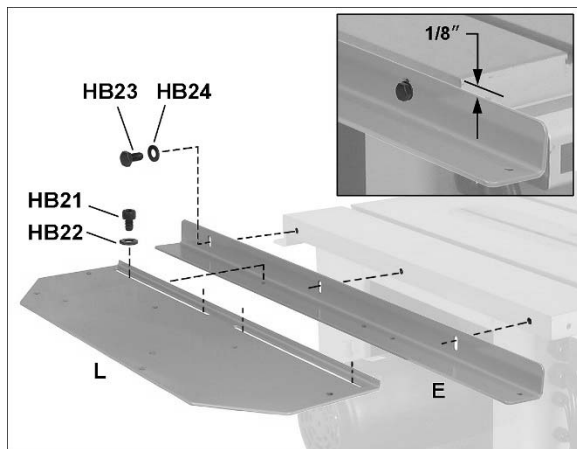

Figure 7-3

3. Position right leg bracket assembly on floor and up against adjustment plate to establish initial height. See Figure 7-4. Change screw hole in leg bracket and/or adjust leveler until surfaces of leg bracket and adjustment plate are flush.

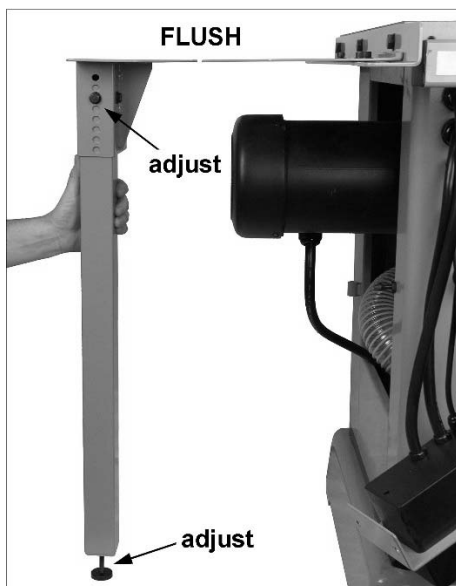

Figure 7-4

4. Position inner guide rail (A) as shown in Figure 7-5, and mount right leg bracket assembly to the threaded holes in rail, in the orientation shown. *Finger tighten screws only.*

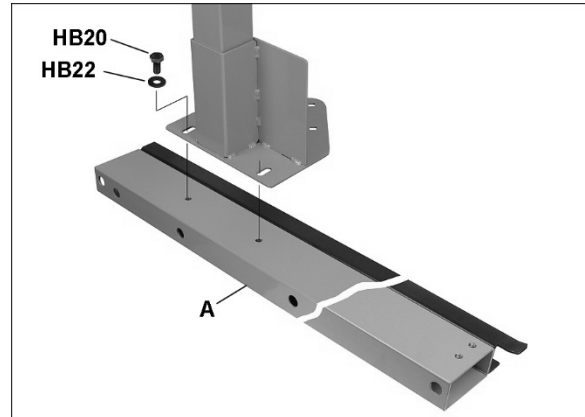

Figure 7-5

5. Install inner guide rail to adjustment plate with four screws and washers. See Figure 7-6. Position rail parallel to saw table, then tighten screws.
6. Install horizontal bearing bracket (O, Figure 7-6) to threaded holes at front of inner rail, with two screws and washers. Tighten screws.

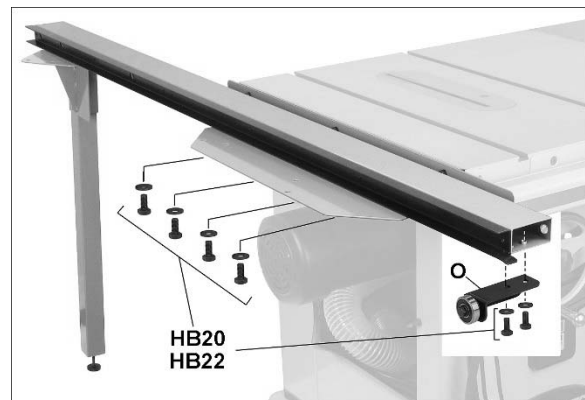

Figure 7-6

7.5 Linkages and outer rail

Use **HARDWARE BAG 3**

1. Install two short linkages (J) and one long linkage (F) with carriage bolts, washers and cap nuts. See Figure 7-7. *Finger tighten only.*

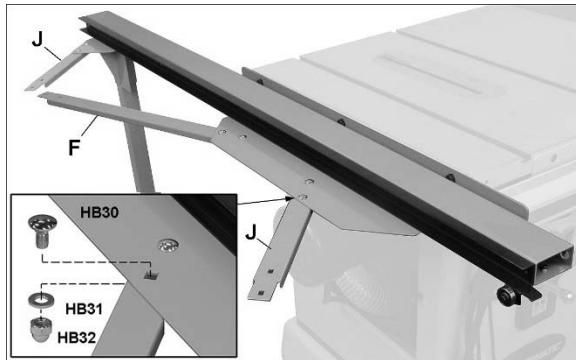

Figure 7-7

2. Position each left leg bracket assembly up against adjustment plate to establish initial height. See inset, Figure 7-8. Change screw hole in leg bracket and/or adjust leveler until surfaces of leg bracket and adjustment plate are flush.
3. Install the two left leg assemblies to the linkages, with 6 carriage bolts, washers and cap nuts, as shown in Figure 7-8. *Finger tighten only.*

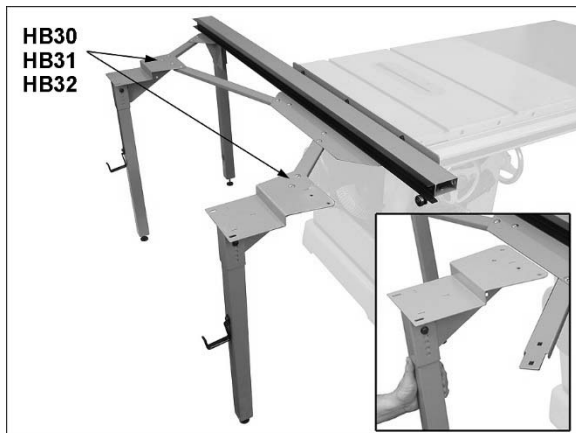

Figure 7-8

4. Use **HARDWARE BAG 2**: Install outer rail (B, Figure 7-9) to leg brackets. NOTE: The wider metal strip faces toward saw. Position rail so that screws are midway in the slots, and *finger tighten only.*
5. Fully tighten all 12 cap nuts/carriage bolts on the linkages (Figures 7-7 and 7-8).
6. Fully tighten screws on right leg bracket assembly that secure it to inner rail (Figure 7-5).

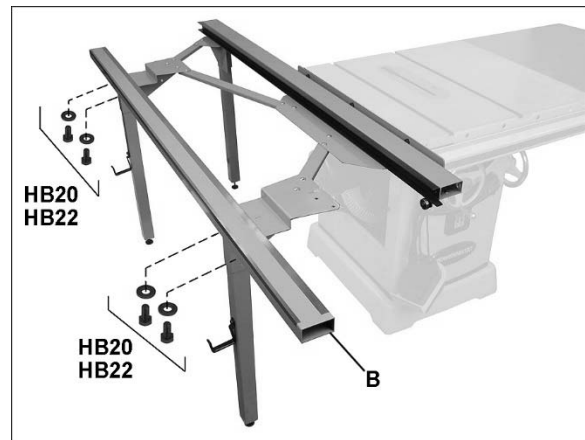

Figure 7-9

7.6 Table installation

Use **HARDWARE BAG 4**

1. Set table (M, figure 7-10) onto rails. The bearings with scrapers on the right side of table should slide into channel on inner guide rail. See inset, Figure 7-10.
2. Mount a table stop to each end of outer rail (Figure 7-11).

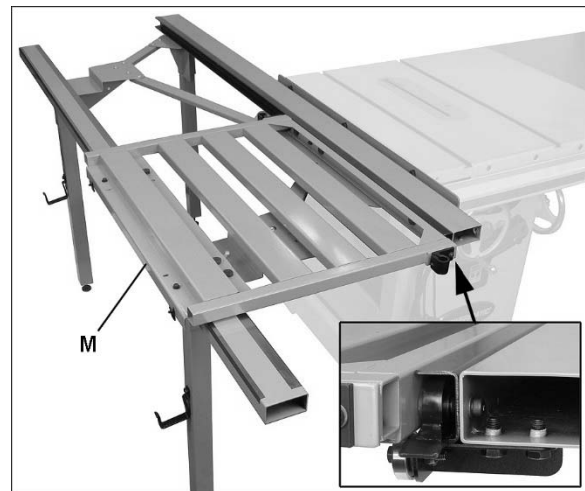

Figure 7-10

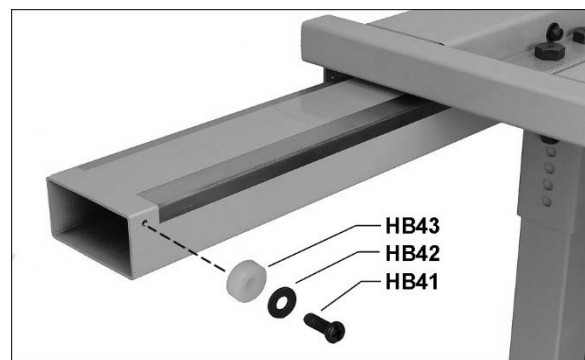

Figure 7-11

7.6.1 Table alignments

For cutting accuracy, the table must slide smoothly and evenly without binding or “play.” Lateral and vertical play can be eliminated as follows.

1. To correct lateral play, loosen bearing screw (M_1 , Figure 7-12), and turn eccentric nut (M_2 , Figure 7-13) until bearing slightly contacts outer rail. Do not adjust bearing too tightly against rail. Tighten screw (M_1).
2. Repeat for the other eccentric bearing (M_3).
3. Move table lock handle (inset, Figure 7-13) to locking position. If handle movement is too tight or too loose, loosen screw (M_4) and adjust eccentric nut (M_5) using same method, then retighten screw.

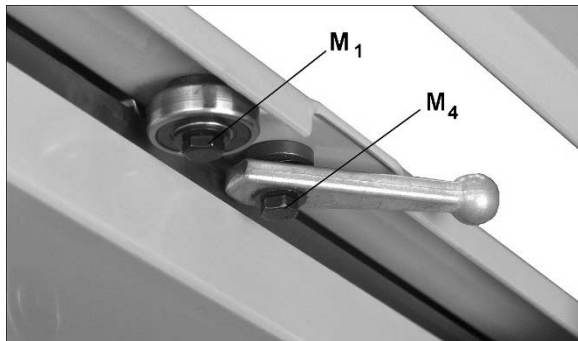

Figure 7-12

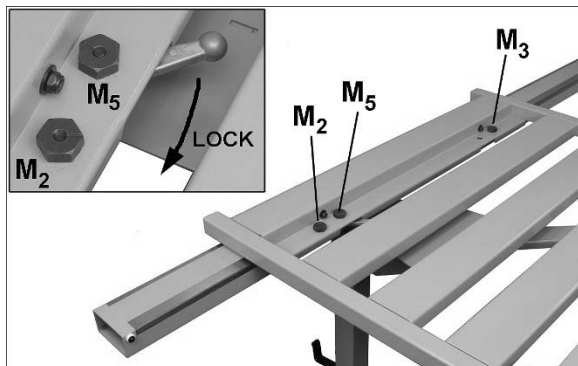

Figure 7-13

4. The table should maintain equal spacing to inner rail during its travel. Verify this by placing 1/8" to 3/16" thick wood or cardboard shims between table and inner rail, as shown in Figure 7-14. Slide table forward and back to the extent of its travel to verify setting.
5. If adjustment is needed, shift outer rail (B, Figure 7-15) toward or away from saw.
6. When table travel is satisfactory, tighten the four screws (HB20) holding outer rail to leg brackets.
7. Remove shims.



Figure 7-14

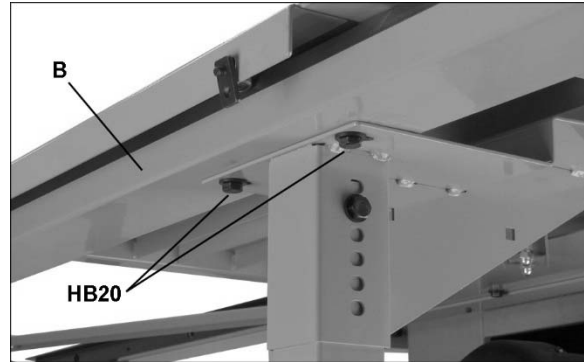

Figure 7-15

8. Install vertical bearing brackets (P, Figure 7-16) to outer rail. Position bracket as far inward toward rail as possible without touching, and tighten lock nut (P_1).
9. Loosen lower nut (P_2) and push bearing up until it just contacts bottom of outer rail. Do not adjust bearing too tightly against rail. Tighten lower nut (P_2).
10. Repeat for the other vertical bearing bracket.

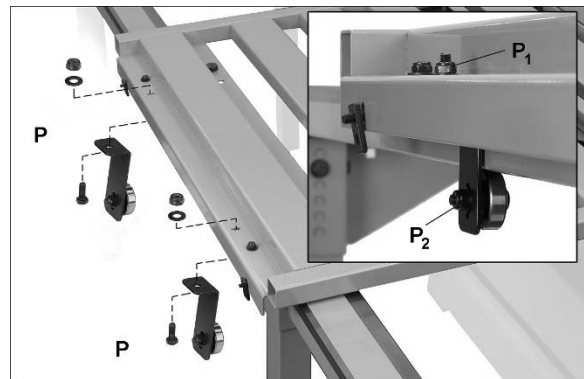

Figure 7-16

Vertical play at the outer rail has now been corrected. To eliminate vertical play at the inner rail:

11. Slide table forward and use the provided T-handle wrench through the holes in inner rail to loosen bearing screw. See Figure 7-17. Turn eccentric nut (M_5) until bearing is just contacting ceiling of rail channel. Do not adjust bearing too tightly to rail. Tighten bearing screw.

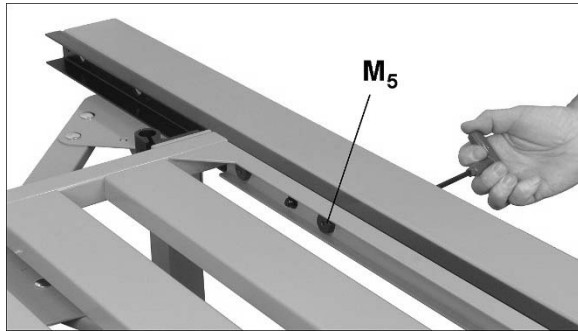

Figure 7-17

12. Adjust front bearing (M_6 , Figure 7-18) in similar manner, until it just contacts inner rail.
13. If needed, adjust scraper bearings (M_7 , Figure 7-18) at front and back so that scrapers just contact inner rail channel.

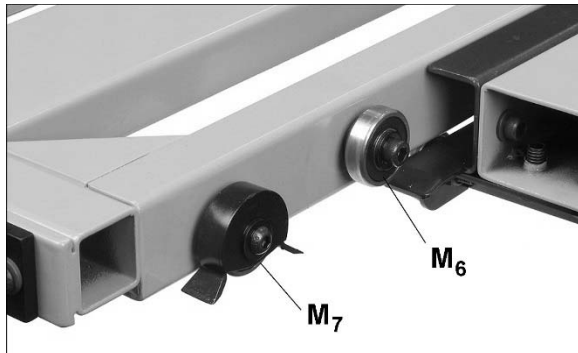

Figure 7-18

14. Check height of horizontal bearing bracket (Figure 7-19). To make adjustments, loosen nut (O_1) and raise or lower bearing to just contact bottom lip of table. Tighten nut.

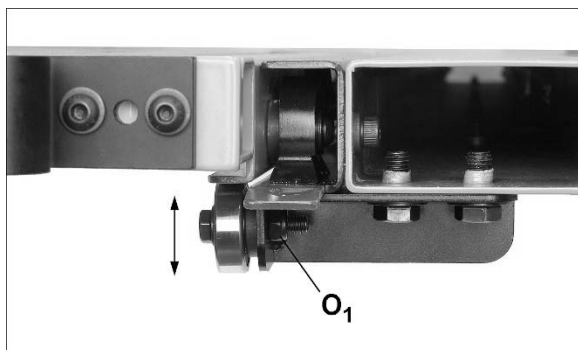

Figure 7-19

15. Slide table forward and back the full extent of its travel. It should slide smoothly without bumps or thumping noises as it engages the rails. Make any additional adjustments as needed.

7.7 Angle adjusting rail installation

1. Slide angle adjusting rail (C, Figure 7-20) onto the two T-nuts (C_1).
2. Position rail so that approximately 4-inches extends past front of table. (This position can be further adjusted later.)
3. Place straight edge over table and angle adjusting rail at front and back, to ensure that rail is level with table along its entire length. See Figure 7-21.
4. Raise or lower rail as needed until level, then tighten the screws on both T-nuts to secure position.

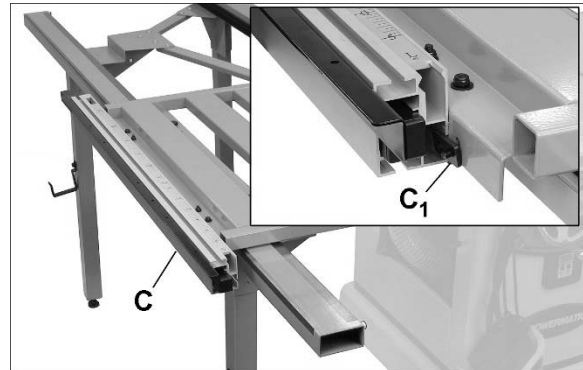

Figure 7-20

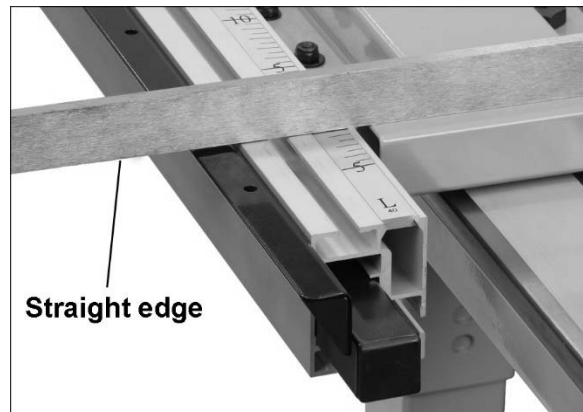

Figure 7-21

5. Insert T-nut with locking handle (R/S, Figure 7-22) into bottom channel of angle adjusting rail. Tighten locking handle to secure push bar (C_2).

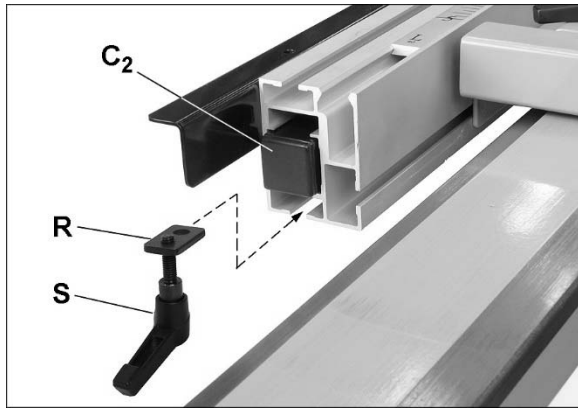

Figure 7-22

7.8 Fence installation

Use HARDWARE BAG 4

1. Install two locking handles (HB40, Figure 7-23) into the pivot hubs on table. To speed this process, pull handle outward and turn screw with flat blade screwdriver, then release handle (see inset, Figure 7-23).

Note: A locking handle can be repositioned at any time by pulling handle outward, rotating it, then releasing.

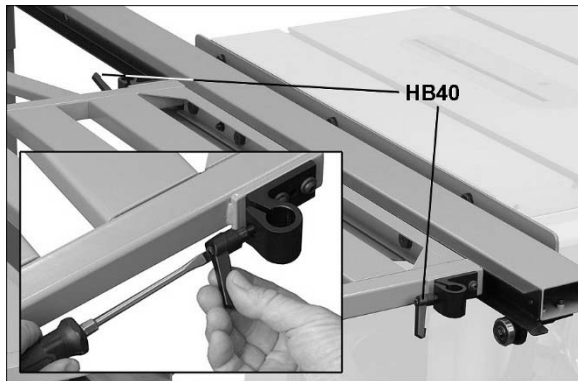

Figure 7-23

2. Rest fence across table, with scale facing up. Then flip it forward so that the two outer holes now face upward. See Figure 7-24.
3. Install angle clamp (T, Figure 7-24) onto fence by inserting T-nut into channel. Slide angle clamp to about 1-foot from left end of fence.
4. Slide pivot post (Q, Figure 7-24) onto fence, and position about 1-1/2 feet from right end of fence.

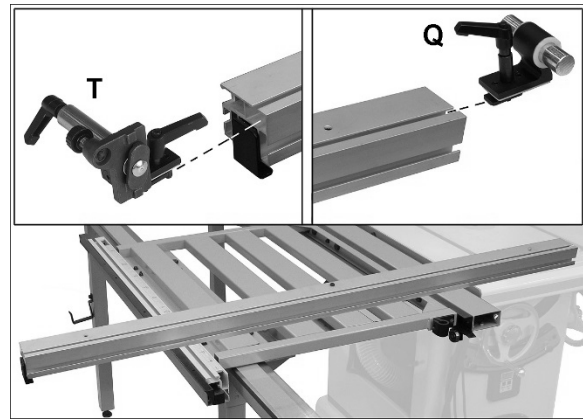

Figure 7-24

5. Flip fence upright (scale faces upward), and install fence into pivot hub on the right. See Figure 7-25.
6. Slide angle clamp along fence until T-nut can be slid into top channel of angle adjusting rail. See Figure 7-25.
7. Make sure pivot post and angle clamp are properly seated in position.



Figure 7-25

8. Pull fence extension (D₁, Figure 7-26) all the way out of fence. Install stop assembly (K) onto extension from opposite end.
9. Reinstall extension into fence, and install two thumb screws (D₂). Tighten thumb screws to secure extension in desired position.

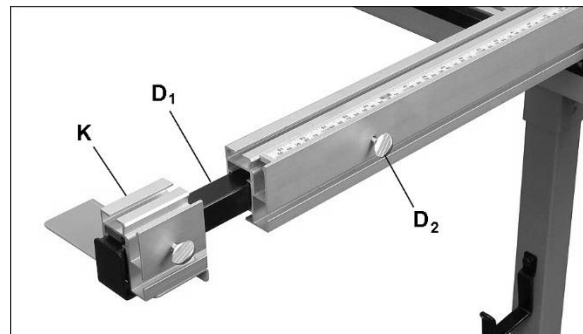

Figure 7-26

The fence can be stored on the hooks mounted to the legs.

7.9 Flip stop

Slide the flip stop (U, Figure 7-27) onto fence by inserting t-nut into channel. The stop can be used in conjunction with the fence scale to make multiple cuts of the same length. (Alignment of fence scale is explained in sect. 8.4.)

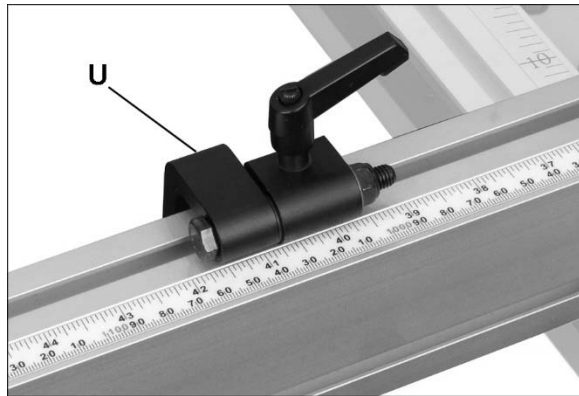

Figure 7-27

7.10 Assembly completion

On your Powermatic table saw, mount on/off switch to guide tube, and reinstall motor cover.

8.0 Additional alignments

⚠WARNING Disconnect table saw from power source (unplug) before making the following alignments.

Once the previous settings from sect. 7.0 have been made, three additional alignments must be established to ensure cutting accuracy:

- ❑ Sliding table is level with saw table (sect. 8.1).
- ❑ Sliding table tracks parallel to blade (sect. 8.2).
- ❑ Fence is set perpendicular, or 90-degrees, to blade at both front position and rear position (sect. 8.3).

8.1 Leveling sliding table

1. Before proceeding, verify that saw table is level with floor.
2. Place a level at different points across sliding table and saw table. See Figure 8-1.
3. Adjust height of leveling feet (HB14) to make tables level. If more adjustment is needed, loosen three screws holding mounting bracket (E) to saw table, and nudge bracket up or down.
4. Tighten screws on mounting bracket (E).

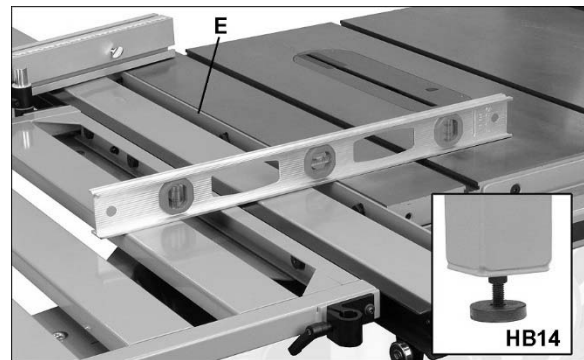

Figure 8-1

8.2 Table-to-blade parallelism

The sliding table must track parallel to blade. This can be checked with a long straight edge or your table saw rip fence. *Make sure your rip fence has already been set parallel to blade.*

1. Raise blade to maximum height.
2. Position rip fence at left side of blade, and lock it to the saw table. If using a straight edge, place it against flat left surface of blade (not tooth edges).
3. With fence mounted in front position, loosen screw (D₃, Figure 8-2) and slide fence scale (D₄, Figure 8-3) until it almost contacts rip fence/straight edge.

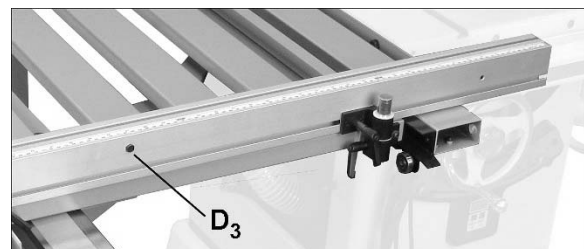

Figure 8-2

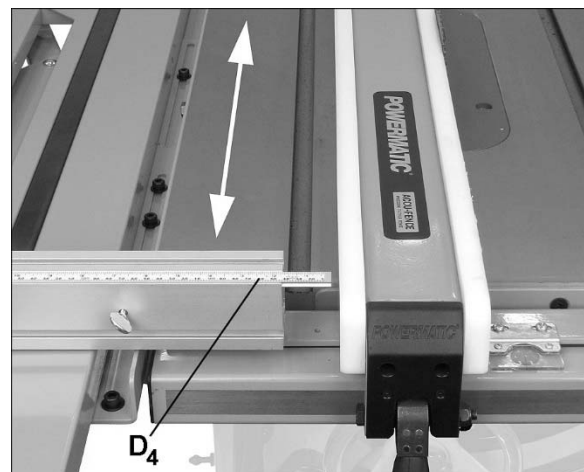

Figure 8-3

4. Move sliding table forward and back. The gap between scale and rip fence/straight edge should remain the same.

5. If variation occurs, loosen screws beneath outer rail (see Figure 7-15) and shift front or back end of outer rail, as needed. Slide table forward and back to verify setting.

NOTE: Maintain even spacing between sliding table and inner rail, as established by the shims in Figure 7-14.

6. Tighten screws beneath outer rail (see Figure 7-15).

8.3 Fence-to-blade squareness

With sliding table set parallel to blade, the fence must now be set 90-degrees to blade while in front and rear position.

8.3.1 Front position

1. Raise blade to maximum height.
2. Install fence in front position, and slide it laterally until it is close to blade, as shown in Figure 8-4.
3. Place a machinist square or similar 90° measuring device against fence and side of blade, as shown. (Use flat surface of blade, not tooth edges.) The square should rest flush against both surfaces.

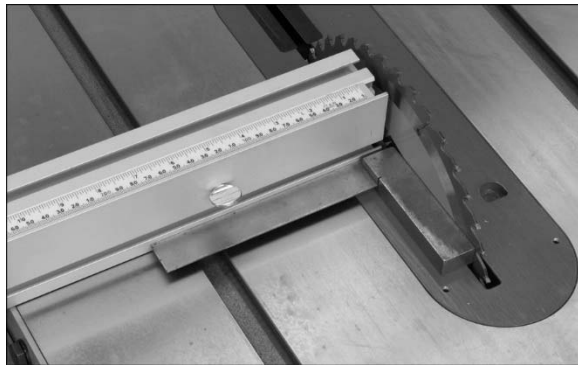

Figure 8-4

4. If square is not flush, loosen both handles on angle clamp (Figure 8-5) and slide end of fence to a position where square sits flush.
5. Tighten angle clamp.

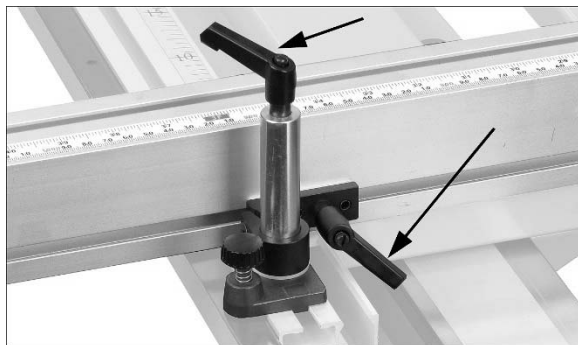

Figure 8-5

6. Loosen screw (C₂, Figure 8-6) on angle rail and slide angle scale (C₃) until zero is aligned with vertical face of fence.
7. Tighten screw (C₂).

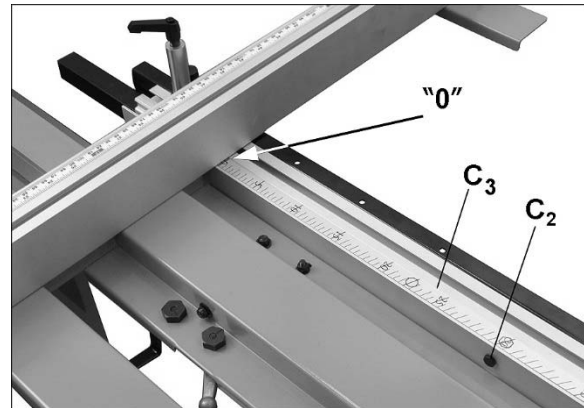

Figure 8-6

8.3.2 Front position – 90° stop

8. Loosen the two T-nuts on angle adjusting rail (see Figure 7-20), and slide angle adjusting rail while pushing down index pin (T₁, Figure 8-7) until first hole from the end engages index pin.
9. Tighten the two T-nuts.
10. The fence is now set for quick return to 90° position, by pushing down index pin (T₁) until it enters hole, then tightening angle clamp.

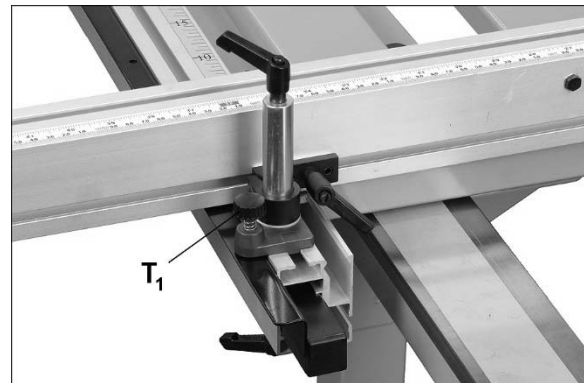

Figure 8-7

8.3.3 Rear position

1. Slide fence extension and stop (see K, Figure 7-26) out of fence.
2. Lift fence from front position and lay it on its side. Remove pivot post and angle clamp from fence, and reverse their locations, as shown in Figure 8-8, with angle clamp about 1 ft. from right end, and pivot post about 1-1/2 ft. from left end.



Figure 8-8

3. Flip fence right side up, rotate 180-degrees, and install it in rear position: Place pivot post into hub, and slide angle clamp into channel of miter fence. See Figure 8-9.



Figure 8-9

4. Slide table until fence is near blade. Place a machinist square against fence and side of raised blade, as was done in Figure 8-5.
5. Loosen angle clamp handles and adjust fence until square lies flush against fence and blade. Tighten angle clamp.

8.3.4 Rear position – 90° stop

6. Loosen screw (C₄, Figure 8-10) and slide rear stop block (C₅) until index pin can engage its hole.
7. Tighten screw (C₄) to secure setting of stop block. The crosscut fence can now be returned rapidly to 90° angle while in rear position.

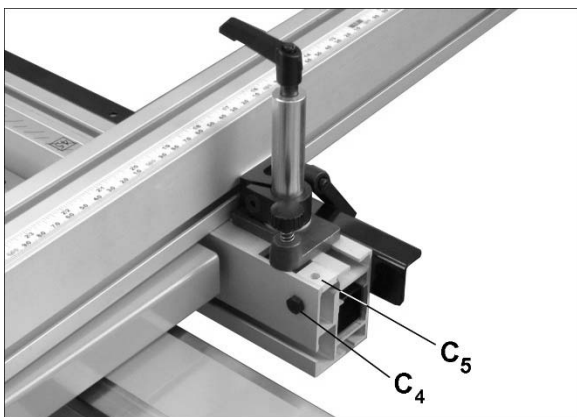

Figure 8-10

8.4 Fence scale and flip stop

8.4.1 Fence at front position

1. Loosen screw (D₃, Figure 8-11) and move fence scale (D₄) flush with right end of fence. Tighten screw (D₃).

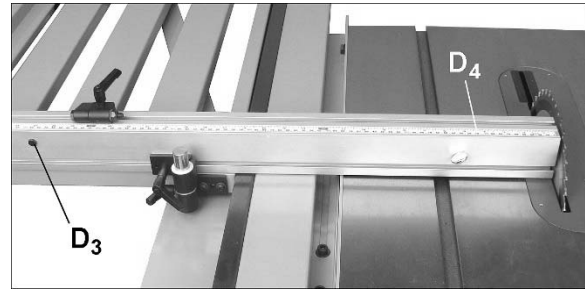

Figure 8-11

2. Loosen fence handles on angle clamp and pivot post, and slide fence to approximately 1/8-inch from blade, as shown in Figure 8-12.
3. Use a separate scale to measure 1-inch from the edge of a blade tooth. (Use tooth edge instead of flat blade surface, to account for actual cut width) See Figure 8-12.
4. Adjust fence so that scale matches the 1-inch distance from blade tooth. Tighten fence in position.

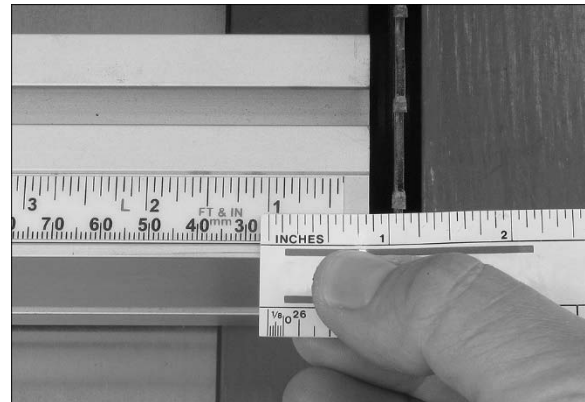

Figure 8-12

5. Raise flip stop (Figure 8-13) and slide it to desired dimension on scale. Tighten handle and lower flip stop. Place a scrap board against flip stop, and make a test cut. Measure the cut to verify scale accuracy, and make any further adjustments if needed.

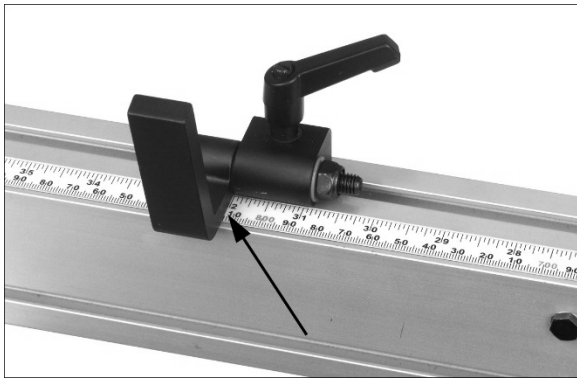

Figure 8-13

8.4.1 Fence at rear position

With fence at rear position, loosen screw (D₃, Figure 8-11). Remove scale, rotate it 180° and slide it back into fence. Number sequence now begins properly from blade area.

Use same method as above for adjusting fence scale in reference to blade.

8.5 Capacity adjustment

To further adjust capacity, loosen screws in mounting bracket (Figure 8-14), and slide entire assembly forward or back, removing any of the screws as necessary.

NOTE: At least two (2) screws must remain in the mounting bracket. Use *more than two whenever possible*.

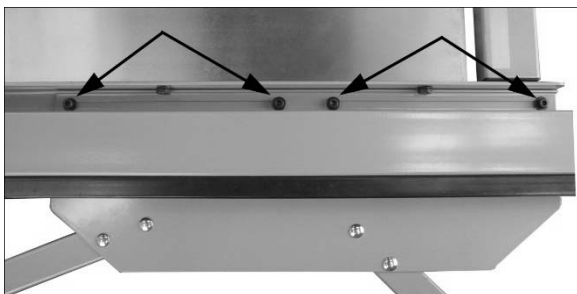

Figure 8-14

9.0 Operations

⚠WARNING Familiarize yourself thoroughly with the correct and safe operation of your table saw before using the sliding table. Failure to comply may cause serious injury.

9.1 Fence position and capacities

With fence in front position, cutting capacity is 39-inches. See Figure 9-1.

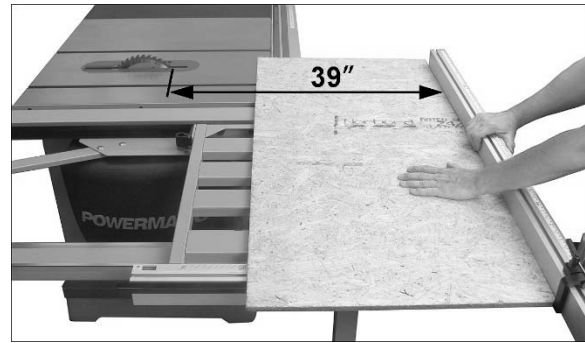

Figure 9-1

With fence in rear position, cutting capacity is 41-inches with panel clearing blade; 49-inches without panel clearing blade. See Figure 9-2.

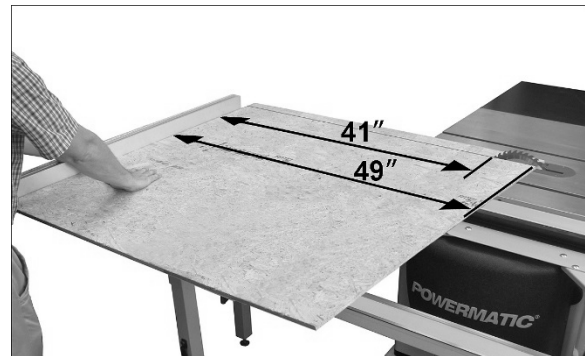

Figure 9-2

NOTE: The above capacities may vary depending upon position of adjusting plate on the saw table. Also, slight variation can occur depending upon thickness of panel and height of saw blade (i.e. where blade tooth engagement begins).

9.2 Cutting angles

Angles up to 50-degrees are possible, with pre-set stops at standard angles.

To make an angled cut:

1. Install fence in front position.
2. Loosen both handles on angle clamp, and slide angle clamp to desired position on angle scale. If setting an angle of 15, 22.5, 30, 45 or 50 degrees, use index pin and hole in angle adjusting rail to quickly find position.
3. Tighten handles on angle clamp.

9.3 General operating procedures

1. Set fence to at least 1/4-inch from blade, and tighten handles to secure position.

⚠CAUTION Always make sure that fence will clear the blade during travel, and that handles are tight to prevent fence from migrating into blade.

2. Blade should have minimal exposure; set height to approximately 1/8-inch above workpiece.
3. Establish position of any work stops.
4. Draw table back and place panel in position against fence.
5. Hold panel securely against fence with one hand, while pushing the fence with the other. See Figure 9-1.
6. For large panels with fence in rear position, loosen handle (S, Figure 9-3) and pull out fence extension bar. Tighten bar in position, and use it to help push panel through the cut.

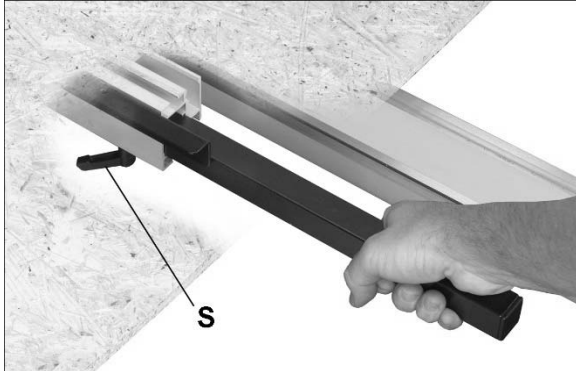

Figure 9-3

10.0 User-maintenance

⚠WARNING Disconnect power to table saw before performing maintenance. Failure to comply may result in serious personal injury.

Keep sliding table clean from sawdust and debris, particularly around bearings and sliding contact points.

Periodically check fasteners for tightness.

Periodically check alignments, such as sliding table level with saw table, height of legs, even travel of sliding table without “play,” alignment of sliding table with blade, etc.

All ball bearings on the unit are pre-lubricated and sealed, and require no further lubrication.

10.1 Additional servicing

Any additional servicing should be performed by authorized service personnel.

11.0 Replacement Parts

Replacement parts are listed on the following pages. To order parts or reach our service department, call 1-800-274-6848 Monday through Friday, 8:00 a.m. to 5:00 p.m., CST. Having the Model Number and Serial Number of your machine available when you call will allow us to serve you quickly and accurately.

Non-proprietary parts, such as fasteners, can be found at local hardware stores, or may be ordered from Powermatic.

Some parts are shown for reference only, and may not be available individually.

11.1.1 Table Assembly – Exploded View

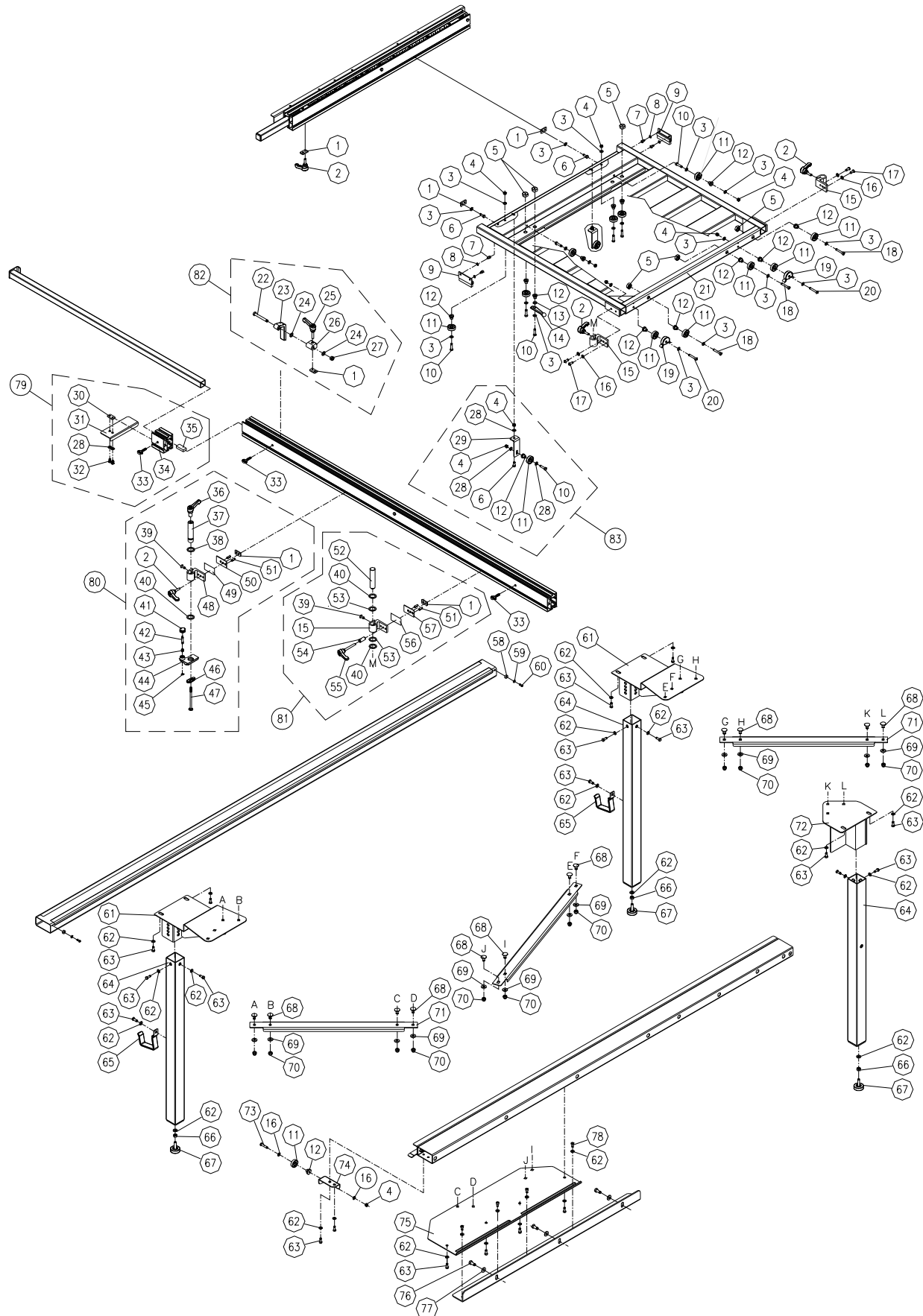

11.1.2 Table Assembly – Parts List

Index No	Part No	Description	Size	Qty
	1794860T	Table Assembly (includes #1 thru #83)		
1	PMST48-101	T-Nut		6
2	PMST48-102	Lock Lever		4
3	TS-1550041	Flat Washer	6.4 x 16 x 1.6T	20
4	TS-1541021	Nylon Lock Hex Nut	M6-1.0P	11
5	PMST48-105	Eccentric Nut		6
6	TS-1482031	Hex Cap Screw	M6-1.0P x 16L	4
7	TS-1502011	Socket Head Cap Screw	M5-0.8P x 8L	4
8	TS-1550031	Flat Washer	5.1 x 12 x 1T	4
9	PMST48-109	Dust Brush		2
10	TS-1482051	Hex Cap Screw	M6-1.0P x 25L	9
11	BB-6200VV	Ball Bearing	6200VV	14
12	PMST48-112	Bearing Shaft		15
13	JAT450-31	Wave Washer	WW-10	1
14	PMST48-114	Lock Handle		1
15	PMST48-115	Pivot Hub		3
16	TS-1550041	Flat Washer	6.3 x 13 x 2T	6
17	TS-2246162	Socket Head Button Screw	M6-1.0P x 16L	4
18	TS-1503061	Socket Head Cap Screw	M6-1.0P x 25L	3
19	PMST48-119	Scraper		2
20	TS-2246302	Socket Head Button Screw	M6-1.0P x 30L	2
21	PMST48-121	Table		1
22	F009484	Hex Cap Screw	M8-1.25P x 65L	1
23	PMST48-123	Flip Stock Stop		1
24	PMST48-124	Nylon Washer		2
25	PMST48-125	Lock Lever		1
26	PMST48-126	Sliding Block		1
27	TS-1541031	Nylon Lock Hex Nut	M8-1.25P	1
28	TS-1550041	Flat Washer	6.5 x 13 x 1T	8
29	PMST48-129	Bearing Bracket		2
30	PMST48-130	T-Nut		1
31	PMST48-131	Stock Support Bracket		1
32	TS-2246122	Socket Head Button Screw	M6-1.0P x 12L	2
33	PMST48-133	Thumb Screw		3
34	PMST48-134	Short Fence		1
35	PMST48-135	Foam Pad		1
36	PMST48-136	Lock Lever		1
37	PMST48-137	Sleeve		1
38	5509372	O-Ring	P14	1
39	TS-1514021	Socket Head Flat Screw	M6-1.0P x 16L	2
40	PMST48-140	Nylon Washer		3
41	PMST48-141	Knob		1
42	PMST48-142	Index Pin		1
43	PMST48-143	Spring		1
44	PMST48-144	Index Pin Seat		1
45	JAT300-13	C-Retaining Ring, Ext	STW-6	1
46	PMST48-146	T-Nut		1
47	PMST48-147	Carriage Bolt		1
48	PMST48-148	Post Hub		1
49	PMST48-149	Tape		1
50	PMST48-150	Anti-Scratch Sheet		1
51	F012078	Roll Pin	6 x 20L	4
52	PMST48-152	Pivot Post		1
53	PMST48-153	Tape		2
54	PMST48-154	Spacer		1
55	PMST48-155	Lock Lever		1
56	PMST48-156	Adhesive Tape		1
57	PMST48-157	Anti-Scratch Sheet		1
58	PMST48-158	Stop Ring		2
59	TS-1550021	Flat Washer	4.3 x 10 x 1T	2

Index No	Part No	Description	Size	Qty
60	TS-1532042	Phillips Pan Head Machine Screw	M4-0.7P x 12L	2
61	PMST48-161	Left Leg Bracket		2
62	TS-1550061	Flat Washer	8.5 x 19 x 2T	27
63	TS-2228161	Hex Cap Screw	M8-1.25P x 16L	20
64	PMST48-164	Leg		3
65	PMST48-165	Storage Hook		2
66	TS-1540061	Hex Nut	M8-1.25P	3
67	PMST48-167	Leveling Foot		3
68	64B-312	Carriage Bolt	M8-1.25P x 16L	12
69	TS-1550061	Flat Washer	8.5 x 16 x 2T	12
70	TS-2331081	Cap Nut	M8-1.25P	12
71	PMST48-171	Linkage, Short	15-1/2"L	2
72	PMST48-172	Right Leg Bracket		1
73	TS-1482061	Hex Cap Screw	M6-1.0P x 30L	1
74	PMST48-174	Bearing Bracket		1
75	PMST48-175	Adjustment Plate		1
76	TS-1491021	Hex Cap Screw	M10-1.5P x 20L	3
77	TS-1550071	Flat Washer	10 x 20 x 2.0T	3
78	TS-1504021	Socket Head Cap Screw	M8-1.25P x 12L	4
79	PMST48-179	Fence Extension Stop Assembly		1
80	PMST48-180	Angle Clamp Assembly		1
81	PMST48-181	Pivot Post Assembly		1
82	PMST48-182	Flip Stop Assembly		1
83	PMST48-183	Bearing Bracket Assembly		1

11.2.1 Rail Assembly – Exploded View

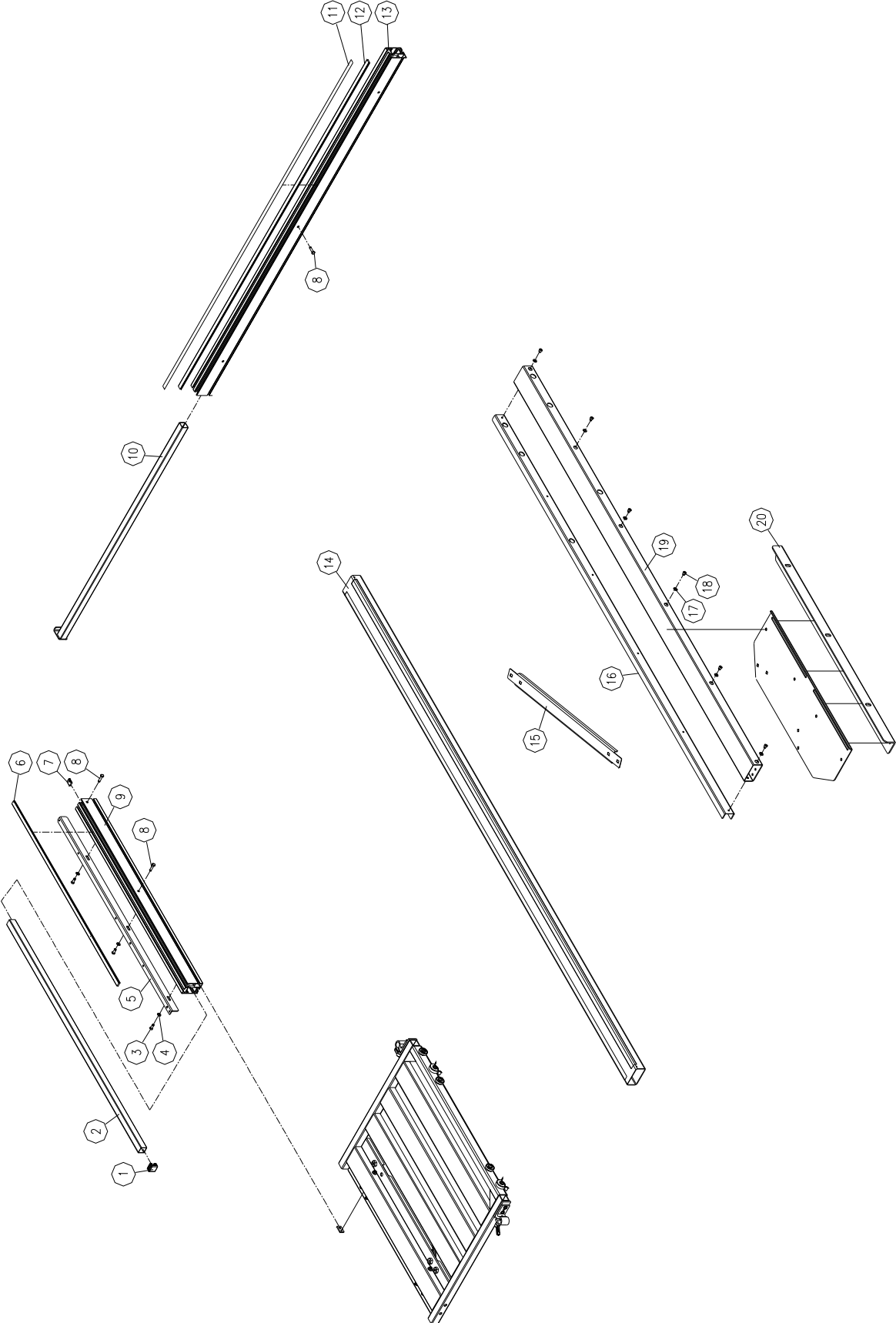

11.2.2 Rail Assembly – Parts List

Index No	Part No	Description	Size	Qty
	1794860R	Rail Assembly (includes #1 thru #20)		1
1	PMST48-201	Plastic Plug		1
2	PMST48-202	Table Push Bar		1
3	TS-1482031	Hex Cap Screw	M6-1.0P x 16	3
4	TS-1550041	Flat Washer	6.4 x 16 x 1.6T	3
5	PMST48-205	Positive Stop Rail		1
6	PMST48-206	Angle Scale		1
7	PMST48-207	90-Degree Stop Block		1
8	TS-1482051	Hex Cap Screw	M6-1.0P x 25L	3
9	PMST48-209	Angle Adjusting Rail		1
10	PMST48-210	Fence Extension Bar		1
	PMST48-212A	Fence Scale Assembly (includes #11,12)		1
11	PMST48-211	Fence Scale		1
12	PMST48-212	Scale Plate		1
13	PMST48-213	Fence		1
14	PMST48-214	Outer Guide Rail		1
15	PMST48-215	Linkage, Long	28-1/2" L	1
16	PMST48-216	Bearing Guide Rail		1
17	TS-1550041	Flat Washer	6.3 x 13 x 2T	6
18	TS-1503011	Socket Head Cap Screw	M6-1.0P x 8L	6
19	PMST48-219	Inner Guide Rail		1
20	PMST48-220	Fixed Bracket		1

12.0 Warranty and Service

Powermatic® warrants every product it sells against manufacturers' defects. If one of our tools needs service or repair, please contact Technical Service by calling 1-800-274-6846, 8AM to 5PM CST, Monday through Friday.

Warranty Period

The general warranty lasts for the time period specified in the literature included with your product or on the official Powermatic branded website.

- Powermatic products carry a limited warranty which varies in duration based upon the product. (See chart below)
- Accessories carry a limited warranty of one year from the date of receipt.
- Consumable items are defined as expendable parts or accessories expected to become inoperable within a reasonable amount of use and are covered by a 90 day limited warranty against manufacturer's defects.

Who is Covered

This warranty covers only the initial purchaser of the product from the date of delivery.

What is Covered

This warranty covers any defects in workmanship or materials subject to the limitations stated below. This warranty does not cover failures due directly or indirectly to misuse, abuse, negligence or accidents, normal wear-and-tear, improper repair, alterations or lack of maintenance. Powermatic woodworking machinery is designed to be used with Wood. Use of these machines in the processing of metal, plastics, or other materials outside recommended guidelines may void the warranty. The exceptions are acrylics and other natural items that are made specifically for wood turning.

Warranty Limitations

Woodworking products with a Five Year Warranty that are used for commercial or industrial purposes default to a Two Year Warranty. Please contact Technical Service at 1-800-274-6846 for further clarification.

How to Get Technical Support

Please contact Technical Service by calling 1-800-274-6846. **Please note that you will be asked to provide proof of initial purchase when calling.** If a product requires further inspection, the Technical Service representative will explain and assist with any additional action needed. Powermatic has Authorized Service Centers located throughout the United States. For the name of an Authorized Service Center in your area call 1-800-274-6846 or use the Service Center Locator on the Powermatic website.

More Information

Powermatic is constantly adding new products. For complete, up-to-date product information, check with your local distributor or visit the Powermatic website.

How State Law Applies

This warranty gives you specific legal rights, subject to applicable state law.

Limitations on This Warranty

POWERMATIC LIMITS ALL IMPLIED WARRANTIES TO THE PERIOD OF THE LIMITED WARRANTY FOR EACH PRODUCT. EXCEPT AS STATED HEREIN, ANY IMPLIED WARRANTIES OF MERCHANTABILITY AND FITNESS FOR A PARTICULAR PURPOSE ARE EXCLUDED. SOME STATES DO NOT ALLOW LIMITATIONS ON HOW LONG AN IMPLIED WARRANTY LASTS, SO THE ABOVE LIMITATION MAY NOT APPLY TO YOU.

POWERMATIC SHALL IN NO EVENT BE LIABLE FOR DEATH, INJURIES TO PERSONS OR PROPERTY, OR FOR INCIDENTAL, CONTINGENT, SPECIAL, OR CONSEQUENTIAL DAMAGES ARISING FROM THE USE OF OUR PRODUCTS. SOME STATES DO NOT ALLOW THE EXCLUSION OR LIMITATION OF INCIDENTAL OR CONSEQUENTIAL DAMAGES, SO THE ABOVE LIMITATION OR EXCLUSION MAY NOT APPLY TO YOU.

Powermatic sells through distributors only. The specifications listed in Powermatic printed materials and on the official Powermatic website are given as general information and are not binding. Powermatic reserves the right to effect at any time, without prior notice, those alterations to parts, fittings, and accessory equipment which they may deem necessary for any reason whatsoever.

Product Listing with Warranty Period

90 Days – Parts; Consumable items
1 Year – Motors, Machine Accessories
2 Year – Woodworking Machinery used for industrial or commercial purposes
5 Year – Woodworking Machinery

NOTE: Powermatic is a division of JPW Industries, Inc. References in this document to Powermatic also apply to JPW Industries, Inc., or any of its successors in interest to the Powermatic brand.

This page intentionally left blank.



427 New Sanford Road
LaVergne, Tennessee 37086
Phone: 800-274-6848
www.powermatic.com