



# Operating Instructions and Parts Manual

## Dual-Sided 16ga. Box and Pan Brake

Model PBF-1650D



**JET**  
427 New Sanford Road  
LaVergne, Tennessee 37086  
Ph.: 800-274-6848  
[www.jettools.com](http://www.jettools.com)

**Part No. M-752130**  
Edition 2 08/2018  
Copyright © 2016 JET



## 1.0 IMPORTANT SAFETY INSTRUCTIONS

READ ALL INSTRUCTIONS BEFORE USING THIS MACHINE.

### **WARNING – To reduce the risk of injury:**

1. Read and understand the entire owner's manual before attempting assembly or operation.
2. Read and understand the warnings posted on the machine and in this manual. Failure to comply with all of these warnings may cause serious injury.
3. Replace the warning labels if they become obscured or removed.
4. This box and pan brake is designed and intended for use by properly trained and experienced personnel only. If you are not familiar with the proper and safe operation of a brake, do not use until proper training and knowledge have been obtained.
5. Do not use this brake for other than its intended use. If used for other purposes, JET disclaims any real or implied warranty and holds itself harmless from any injury that may result from that use.
6. Always wear ANSI Z87.1 approved safety glasses or face shield while using this brake. (Everyday eyeglasses only have impact resistant lenses; they are *not* safety glasses.)
7. Before operating this machine, remove tie, rings, watches and other jewelry, and roll sleeves up past the elbows. Do not wear loose clothing. Confine long hair. Non-slip footwear or anti-skid floor strips are recommended.
8. Wear ear protectors (plugs or muffs) if noise reaches unsafe levels.
9. Do not operate this machine while tired or under the influence of drugs, alcohol or any medication.
10. Remove adjusting keys and wrenches. Form a habit of checking to see that keys and adjusting wrenches are removed from the machine before turning it on.
11. Keep safety guards in place at all times when the machine is in use. If removed for maintenance purposes, use extreme caution and replace the guards immediately after completion of maintenance.
12. Check damaged parts. Before further use of the machine, a guard or other part that is damaged should be carefully checked to determine that it will operate properly and perform its intended function. Check for alignment of moving parts, binding of moving parts, breakage of parts, mounting and any other conditions that may affect its operation. A guard or other part that is damaged should be properly repaired or replaced.
13. Provide for adequate space surrounding work area and non-glare, overhead lighting.
14. Keep the floor around the machine clean and free of scrap material, oil and grease.
15. Keep visitors a safe distance from the work area. Keep children away.
16. Make your workshop child proof with padlocks, master switches or by removing starter keys.
17. Give your work undivided attention. Looking around, carrying on a conversation and "horse-play" are careless acts that can result in serious injury.
18. Maintain a balanced stance at all times so that you do not fall into the blade or other moving parts. Do not overreach or use excessive force to perform any machine operation.
19. Use recommended accessories; improper accessories may be hazardous.
20. Maintain tools with care. Keep blades sharp and clean for the best and safest performance. Follow instructions for lubricating and changing accessories.
21. Do not stand on the machine. Serious injury could occur if the machine tips over.
22. Remove loose items and unnecessary work pieces from the area before operating the machine.
23. Do not use in dangerous environment. Do not use machine in damp or wet location, or expose to rain. Keep work area well lighted.
24. Sheet metal stock has sharp edges; use caution when handling to prevent cuts.
25. Keep hands clear of bending area while operating.
26. Do not exceed rated capacity of brake.
27. The brake should be secured to floor with appropriate fasteners.

**⚠ WARNING:** This product can expose you to chemicals including lead which is known to the State of California to cause cancer and birth defects or other reproductive harm. For more information go to <http://www.p65warnings.ca.gov>.

**Familiarize yourself with the following safety notices used in this manual:**

**CAUTION** This means that if precautions are not heeded, it may result in minor injury and/or possible machine damage.

**⚠ WARNING** This means that if precautions are not heeded, it may result in serious, or possibly even fatal, injury.

**⚠ WARNING:** Some dust, fumes and gases created by power sanding, sawing, grinding, drilling, welding and other construction activities contain chemicals known to the State of California to cause cancer and birth defects or other reproductive harm. Some examples of these chemicals are:

- lead from lead based paint
- crystalline silica from bricks, cement and other masonry products
- arsenic and chromium from chemically treated lumber

Your risk of exposure varies, depending on how often you do this type of work. To reduce your exposure to these chemicals, work in a well-ventilated area and work with approved safety equipment, such as dust masks that are specifically designed to filter out microscopic particles. For more information go to <http://www.p65warnings.ca.gov/> and <http://www.p65warnings.ca.gov/wood>.

## SAVE THESE INSTRUCTIONS

### 2.0 About this manual

This manual is provided by JET, covering the safe operation and maintenance procedures for a JET Model BPF-1650D Dual-Sided Box and Pan Brake. This manual contains instructions on installation, safety precautions, general operating procedures, maintenance instructions and parts breakdown. Your machine has been designed and constructed to provide consistent, long-term operation if used in accordance with the instructions as set forth in this document.

This manual is not intended to be a guide to sheet metal bending, bend allowances, material choice, etc. Consult a machinery's handbook and/or experienced users for such information. Whatever accepted methods or materials are used, always make personal safety a priority.

If there are questions or comments, please contact your local supplier or JET. JET can also be reached at our web site: [www.jettools.com](http://www.jettools.com).

Retain this manual for future reference. If the machine transfers ownership, the manual should accompany it.

**⚠ WARNING** Read and understand the entire contents of this manual before attempting assembly or operation! Failure to comply may cause serious injury!

**Register your product online -** <http://www.jettools.com/us/en/service-and-support/warranty/registration/>

## 3.0 Table of contents

Section	Page
1.0 IMPORTANT SAFETY INSTRUCTIONS .....	2
2.0 About this manual .....	3
3.0 Table of contents.....	4
4.0 Specifications for 16x50 Box and Pan Brake .....	5
4.1 Floor Diagram.....	5
5.0 Features and terminology .....	6
6.0 Setup and assembly.....	7
6.1 Unpacking and cleanup.....	7
6.2 Contents of shipping container.....	7
6.3 Tools required for assembly .....	7
6.4 Assembly.....	7
7.0 Operation .....	7
7.1 Finger spacing.....	7
7.2 Adjusting setback .....	7
7.3 Adjusting clamping pressure .....	8
7.4 Repeat bends .....	8
7.5 General procedure .....	8
8.0 User-maintenance.....	8
8.1 Lubrication.....	8
8.2 Additional servicing .....	8
9.0 Troubleshooting PBF-1650D Box and Pan Brake.....	8
10.0 Replacement Parts.....	8
10.1.1 BPF-1650D Box and Pan Brake – Exploded View.....	9
10.1.2 PBF-1650D Box and Pan Brake – Parts List.....	10
11.0 Warranty and service .....	12

## 4.0 Specifications for 16x50 Box and Pan Brake

Model Number..... **PBF-1650D**  
 Stock Number ..... 752130

### Materials:

Frame ..... welded steel plate/tubing  
 Clamping fingers..... ground steel  
 Clamping block ..... precision ground steel

### Capacities:

Bending length..... 50 in. (1270 mm)  
 Maximum thickness, mild steel ..... 16 ga. (1.5 mm)  
 Bending angle..... 0 – 135 deg.  
 Maximum beam lift..... 1-13/16 in. (46 mm)  
 Maximum box depth ..... 2.5 in. (63.5 mm)  
 Minimum flange in capacity material..... 0.4 in. (10mm)  
 Nose angle (upper fingers) ..... 42 deg.  
 Nose radius..... 1/32 in. (0.79 mm)  
 Number of fingers ..... 12 upper, 12 lower  
 Finger widths ..... 1, 1-1/8, 1-3/8, 1-1/2, 1-3/4, 2, 3, 4, 6, 7-3/4, 10, 10-5/8 in.

### Weights:

Net ..... 772 lb (350 kg)  
 Shipping..... 849 lb (385 kg)

### Dimensions:

Height, floor to working surface ..... 35-1/2 in. (902 mm)  
 Shipping (LxWxH)..... 67-3/8 x 28 x 51-1/2 in. (171 x 71 x 131 cm)  
 Assembled (LxWxH) ..... 63 x 38 x 45 in. (160 x 97 x 114 cm)

*The specifications in this manual were current at time of publication, but because of our policy of continuous improvement, JET reserves the right to change specifications at any time and without prior notice, without incurring obligations.*

*L=length, W=width, H=height*

## 4.1 Floor Diagram

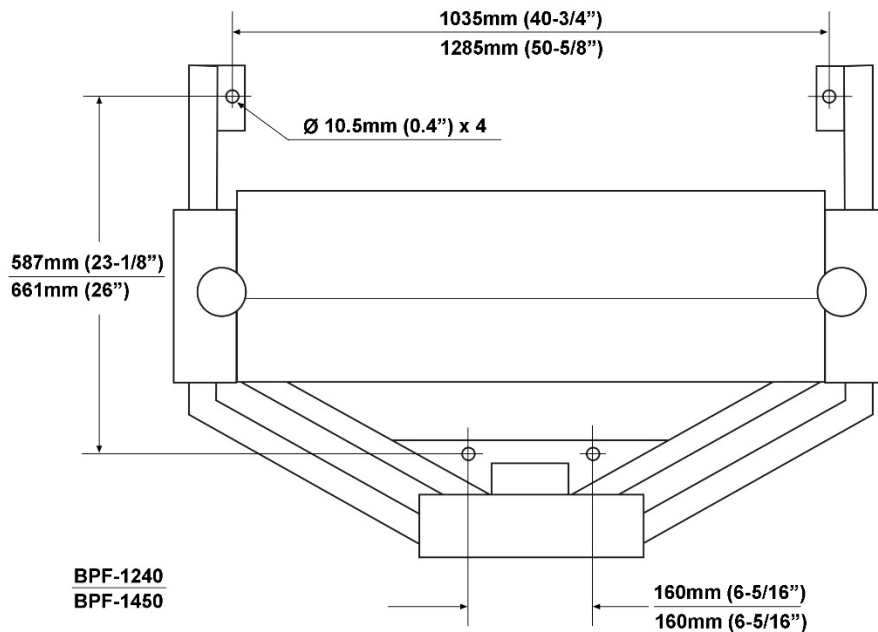

Figure 1

## 5.0 Features and terminology

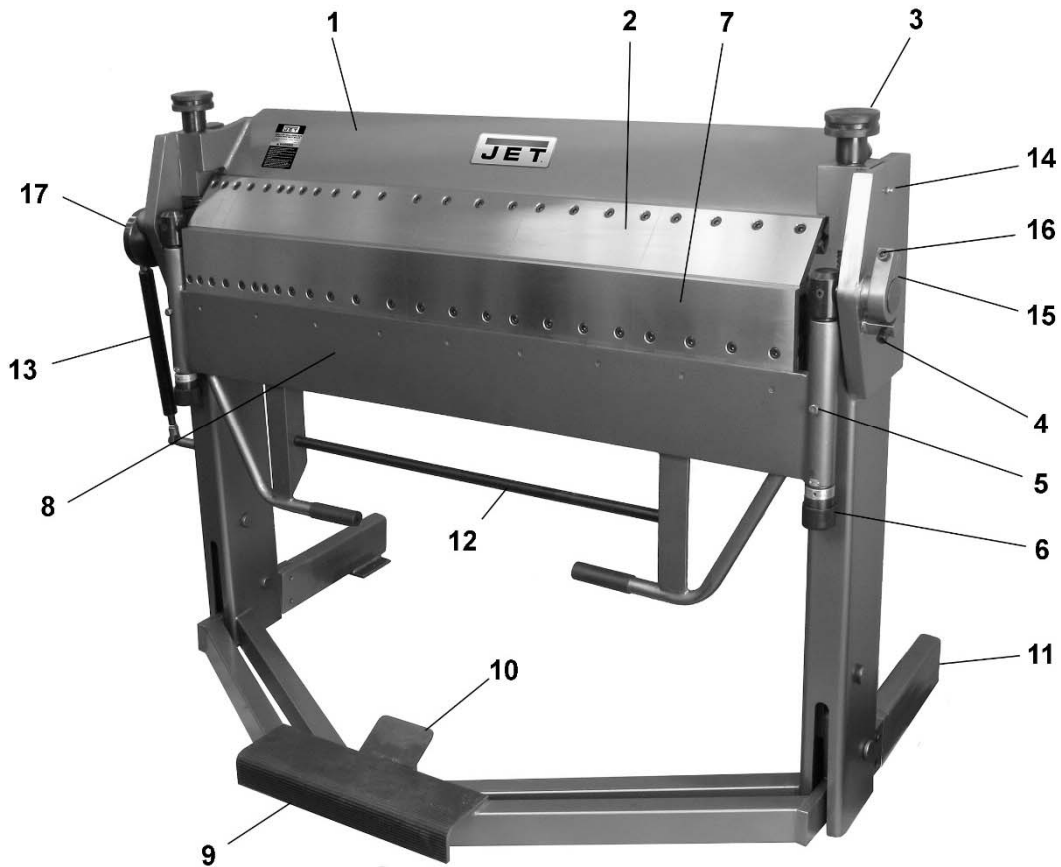

Figure 2

- |                                 |                          |
|---------------------------------|--------------------------|
| 1. Clamping leaf                | 10. Foot pedal lock      |
| 2. Clamping fingers             | 11. Leg extension (x2)   |
| 3. Clamping adjustment nut (x2) | 12. Crown adjustment rod |
| 4. Stop bolt                    | 13. Air spring           |
| 5. Setback locking screw (x2)   | 14. Grease fitting (x2)  |
| 6. Setback knob (x2)            | 15. Stop collar          |
| 7. Bending leaf fingers         | 16. Stop collar screw    |
| 8. Bending leaf                 | 17. Eccentric disc       |
| 9. Foot pedal for clamping      |                          |

## 6.0 Setup and assembly

**⚠WARNING** Read and understand all assembly instructions before attempting assembly. Failure to comply may cause serious injury.

### 6.1 Unpacking and cleanup

Inspect contents of shipping container for shipping damage. Report any damage to your distributor.

Remove all contents from carton, and compare to the contents list in this manual. Report any part shortages to your distributor.

Do not discard carton or packing material until machine is assembled and working properly.

Exposed metal areas may have a rust protectant applied. Remove this with a soft rag and solvent such as kerosene. (Do not use gasoline, paint thinner, acetone, etc., as these will damage painted surfaces.)

### 6.2 Contents of shipping container

- 1 Box and Pan Brake
- 2 Support legs with screws
- 1 Instructions and Parts Manual (not shown)
- 1 Warranty Card (not shown)

### 6.3 Tools required for assembly

8mm hex key

### 6.4 Assembly

Numbers in parentheses refer to items in Figure 2.

1. Remove any straps or screws securing the brake, and raise machine using properly rated lifting equipment. See Figure 3 for lifting strap placement.

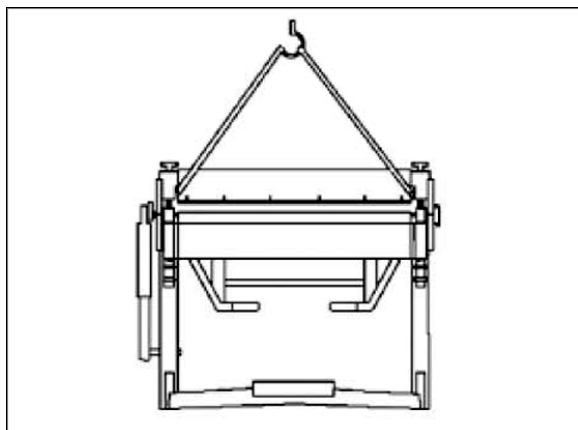

Figure 3

**⚠WARNING** Continue to stabilize machine while installing support legs.

2. Attach the two leg extensions (11) with the provided socket head screws and flat washers.
3. Secure brake to floor using lag screws or similar system. See diagram, Figure 1. Also level the brake; use shims if needed.
4. The stop collar screw (16) has been tightened for shipping purposes. This screw must be loosened to allow clamping machine adjustments.

## 7.0 Operation

Numbers in parentheses refer to items in Figure 2.

### 7.1 Finger spacing

Upper (2) and lower (7) fingers are mounted on T-nuts that slide within the underlying channel. Remove fingers by removing the screw(s); or reposition fingers at any place along the beam by loosening screw and sliding the T-nuts. **Firmly tighten screws on fingers before operating.**

### 7.2 Adjusting setback

The bending leaf lower fingers (7) must be adjusted for proper clearance or "setback" (A, Figure 3) based on material thickness (B, Figure 3). Generally, setback for material within four gauges of capacity should be twice the thickness of material. For lighter gauges, use 1-1/2 times the material thickness. Consult a machinery handbook for bend allowances.

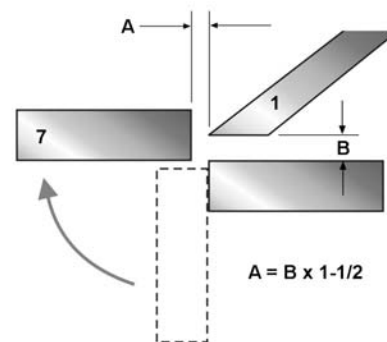

Figure 3

1. Loosen setback locking screws (5).
2. Rotate setback knobs (6) in equal amounts (clockwise decreases distance). Refer to adjoining scale, marked with 0.002-inch graduations.  
  
Note: When increasing distance (counter-clockwise), you may have to pull back slightly on the bending leaf to take up any backlash.
3. Bring clamping leaf into position and check setback.
4. Repeat above steps until proper distance is achieved.

5. Tighten locking screws (5).

If a crown develops in the material, this can be adjusted out by loosening or tightening the hex nuts on the crown adjustment rod (12). Note: This rod has been correctly set by the manufacturer and should only be adjusted when needed.

### 7.3 Adjusting clamping pressure

Clamping pressure may vary depending upon material gauge. Pressure should be great enough to hold material securely, but not so much that it becomes difficult to clamp.

Rotate clamping adjustment nuts (3) equally to set clamping pressure. Proper adjustment will allow foot pedal (9) to be locked (10).

### 7.4 Repeat bends

Loosen stop collar screw (16) and adjust stop bolt (4) to limit swing of bending leaf. Retighten screw (16).

### 7.5 General procedure

1. Adjust upper and/or lower fingers for width of material and type of bend.
2. Adjust for setback and clamping pressure.
3. Position stop bolt if needed.

4. Align material in machine and press foot pedal until it locks.
5. Raise bending leaf to desired angle.
6. Lower bending leaf and press foot pedal lock to release material.

## 8.0 User-maintenance

Periodically wipe down machine with a soft rag. Keep upper and lower fingers clean and clear of debris. Apply light coat of SAE30 oil to upper and lower fingers.

Periodically check tightness of fasteners.

### 8.1 Lubrication

Daily insert a multi-purpose grease into the two fittings (14).

Lightly apply grease to pivot points around machine, such as setback rods and eccentric disc.

Apply light coat of SAE30 oil to all machined (unpainted) parts when not in use, to inhibit rust.

### 8.2 Additional servicing

Any additional servicing should be performed by an authorized service technician.

## 9.0 Troubleshooting PBF-1650D Box and Pan Brake

Symptom	Possible Cause	Correction
Bends created with great difficulty.	Machine capacity exceeded.	Use material within capacity.
	Incorrect setback.	Increase setback.
Clamping leaf will not clamp properly.	Improper adjustment.	Decrease distance between fingers and beam.
	Clamping not even across width.	Rotate adjustment nuts equal amount.
Bend radius not consistent across material.	Machine capacity exceeded.	Use material within capacity.
	Bending leaf edge not parallel to fingers.	Adjust bending leaf equally on both ends.
	Bending leaf has crown.	Correct with crown adjustment rod.

## 10.0 Replacement Parts

Replacement parts are listed on the following pages. To order parts or reach our service department, call 1-800-274-6848 Monday through Friday, 8:00 a.m. to 5:00 p.m. CST. Having the Model Number and Serial Number of your machine available when you call will allow us to serve you quickly and accurately.

Non-proprietary parts, such as fasteners, can be found at local hardware stores, or may be ordered from JET.

Some parts are shown for reference only, and may not be available individually.



10.1.1 BPF-1650D Box and Pan Brake – Exploded View

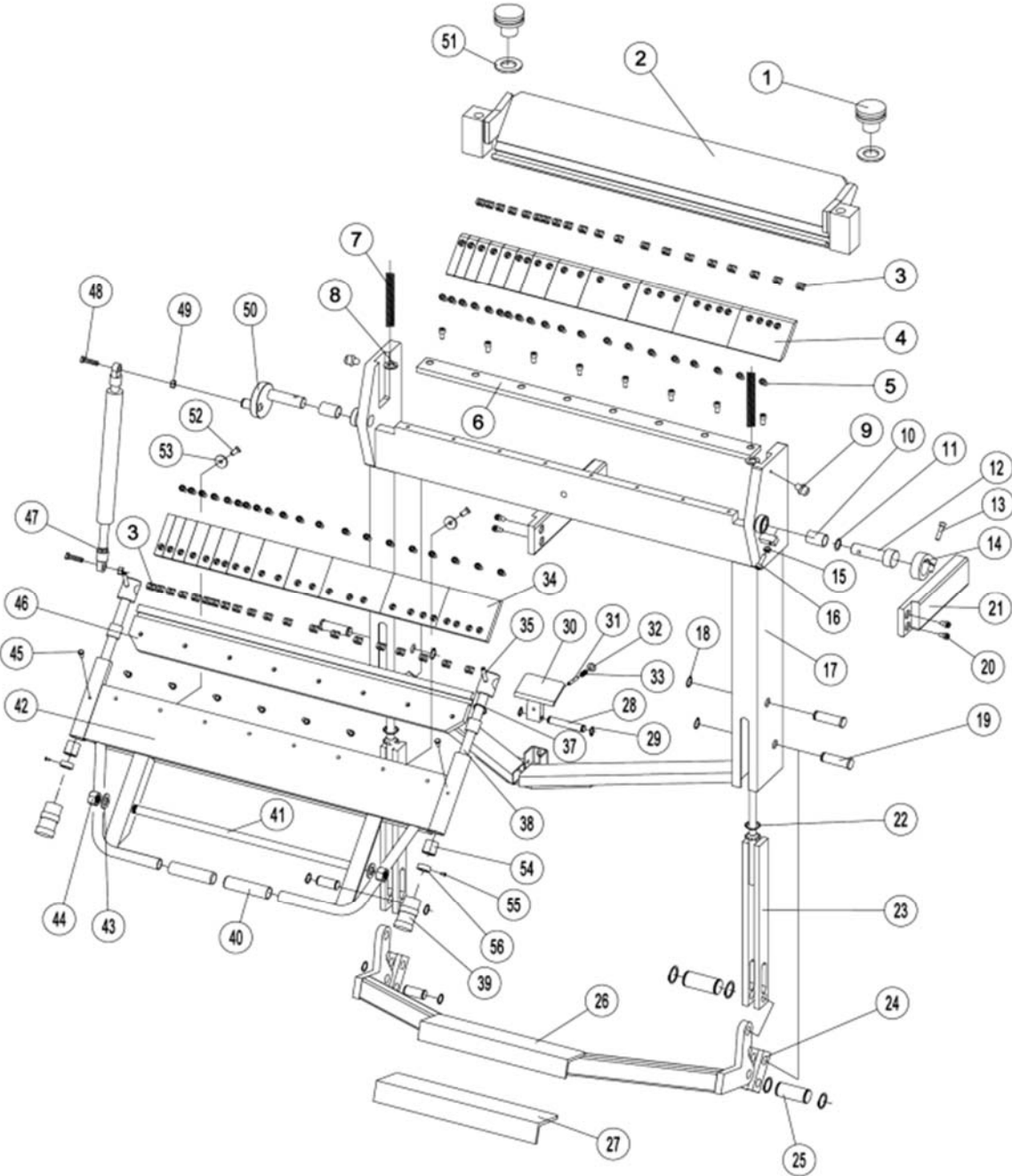

## 10.1.2 PBF-1650D Box and Pan Brake – Parts List

Index No	Part No	Description	Size	Qty
1	H40-210	Adjusting Nut		2
2	PBF1650D-02	Clamping Leaf		1
3	PBF1650D-03	T-Nut		48
4-1	PBF1650D-04-1	Upper Finger	1"	1
4-2	PBF1650D-04-2	Upper Finger	1-1/8"	1
4-3	PBF1650D-04-3	Upper Finger	1-3/8"	1
4-4	PBF1650D-04-4	Upper Finger	1-1/2"	1
4-5	PBF1650D-04-5	Upper Finger	1-3/4"	1
4-6	PBF1650D-04-6	Upper Finger	2"	1
4-7	PBF1650D-04-7	Upper Finger	3"	1
4-8	PBF1650D-04-8	Upper Finger	4"	1
4-9	PBF1650D-04-9	Upper Finger	6"	1
4-10	PBF1650D-04-10	Upper Finger	7-3/4"	1
4-11	PBF1650D-04-11	Upper Finger	10"	1
4-12	PBF1650D-04-12	Upper Finger	10-5/8"	1
5	TS-1505021	Socket Head Cap Screw	M10x20	66
6	PBF1650D-06	Clamping Block		1
7	PBF1650D-07	Adjusting Nut Spring		2
8	TS-155011	Flat Washer	20mm	6
9	PBF1650D-09	Grease Fitting	M8x1	2
10	H40-227	Bushing		2
11	H40-226	Flat Washer	30	2
12	H40-209	Bending Leaf Pin		1
13	TS-1505051	Socket Head Cap Screw	M10x35	1
14	H40-204	Stop Collar		1
15	TS-1540071	Hex Nut	M10	1
16	TS-1505061	Socket Head Cap Screw	M10x40	1
17	PBF1650D-17	Leg		2
18	BPF1240-18	Ext. Retaining Ring	25mm	13
19	H40-208	Leg Pin		3
20	TS-1505041	Socket Head Cap Screw	M10x30	4
21	H40-217-3G	Extension Bracket		2
22	PBF1650D-22	Disc Spring	Ø40xØ20x1mm	4
23	H40-205	Rod		2
24	H40-206	Foot Pedal Lever		4
25	H40-207	Lever Pin		4
26	PBF1650D-26	Foot Pedal		1
27	H40-402	Tread Plate Rubber		1
28	H40-211	Roll Pin		1
29	BPF1240-29	Ext. Retaining Ring	10mm	2
30	H40-213	Foot Pedal Lock		1
31	BPF1240-31	Spring Pin	8x50mm	1
32	TS-1550061	Flat Washer	8mm	1
33	H40-212	Pedal Lock Spring		1
34-1	PBF1650D-34-1	Lower Finger	1"	1
34-2	PBF1650D-34-2	Lower Finger	1-1/8"	1
34-3	PBF1650D-34-3	Lower Finger	1-3/8"	1
34-4	PBF1650D-34-4	Lower Finger	1-1/2"	1
34-5	PBF1650D-34-5	Lower Finger	1-3/4"	1
34-6	PBF1650D-34-6	Lower Finger	2"	1
34-7	PBF1650D-34-7	Lower Finger	3"	1
34-8	PBF1650D-34-8	Lower Finger	4"	1
34-9	PBF1650D-34-9	Lower Finger	6"	1
34-10	PBF1650D-34-10	Lower Finger	7-3/4"	1
34-11	PBF1650D-34-11	Lower Finger	10"	1
34-12	PBF1650D-34-12	Lower Finger	10-5/8"	1
35	BPF1240-31	Spring Pin	8x50mm	2
37	PBF1650D-37	O-Ring	25x3.55mm	2
38	PBF1650D-38	Setback Rod		2

Index No	Part No	Description	Size	Qty
39	PBF1650D-39	Setback Knob		2
40	PBF1650D-40	Operating Handle		2
41	PBF1650D-41	Adjusting Rod		1
42	PBF1650D-42	Bending Leaf		1
43	TS-1550111	Flat Washer	20	2
44	TS-2310201	Hex Nut	M20	2
45	TS-2228161	Hex Cap Screw	M8x16	2
46	PBF1650D-46	Fixing Plate		1
47	PBF1650D-47	Air Spring		1
48	TS-2211451	Hex Cap Screw	M12x45	2
49	TS-2311121	Hex Nut	M12	2
50	PBF1650D-50	Eccentric Holder		1
51	TS-155011	Flat Washer	M20	2
52	TS-1502021	Socket Head Cap Screw	M5x10	2
53	PBF1650D-53	Rubber Pad		2
54	PBF1650D-54	Bushing		4
55	TS-1521031	Socket Set Screw	M4x8	2
56	PBF1650D-56	Scale		2
	LM000240	ID/Warning Label, PBF-1650D (not shown)		1
	JET-165	JET Logo (not shown)	165x68mm	1

## 11.0 Warranty and service

JET warrants every product it sells against manufacturers' defects. If one of our tools needs service or repair, please contact Technical Service by calling 1-800-274-6846, 8AM to 5PM CST, Monday through Friday.

### Warranty Period

The general warranty lasts for the time period specified in the literature included with your product or on the official JET branded website.

- JET products carry a limited warranty which varies in duration based upon the product. (See chart below)
- Accessories carry a limited warranty of one year from the date of receipt.
- Consumable items are defined as expendable parts or accessories expected to become inoperable within a reasonable amount of use and are covered by a 90 day limited warranty against manufacturer's defects.

### Who is Covered

This warranty covers only the initial purchaser of the product from the date of delivery.

### What is Covered

This warranty covers any defects in workmanship or materials subject to the limitations stated below. This warranty does not cover failures due directly or indirectly to misuse, abuse, negligence or accidents, normal wear-and-tear, improper repair, alterations or lack of maintenance. JET woodworking machinery is designed to be used with Wood. Use of these machines in the processing of metal, plastics, or other materials outside recommended guidelines may void the warranty. The exceptions are acrylics and other natural items that are made specifically for wood turning.

### Warranty Limitations

Woodworking products with a Five Year Warranty that are used for commercial or industrial purposes default to a Two Year Warranty. Please contact Technical Service at 1-800-274-6846 for further clarification.

### How to Get Technical Support

Please contact Technical Service by calling 1-800-274-6846. **Please note that you will be asked to provide proof of initial purchase when calling.** If a product requires further inspection, the Technical Service representative will explain and assist with any additional action needed. JET has Authorized Service Centers located throughout the United States. For the name of an Authorized Service Center in your area call 1-800-274-6846 or use the Service Center Locator on the JET website.

### More Information

JET is constantly adding new products. For complete, up-to-date product information, check with your local distributor or visit the JET website.

### How State Law Applies

This warranty gives you specific legal rights, subject to applicable state law.

### Limitations on This Warranty

JET LIMITS ALL IMPLIED WARRANTIES TO THE PERIOD OF THE LIMITED WARRANTY FOR EACH PRODUCT. EXCEPT AS STATED HEREIN, ANY IMPLIED WARRANTIES OF MERCHANTABILITY AND FITNESS FOR A PARTICULAR PURPOSE ARE EXCLUDED. SOME STATES DO NOT ALLOW LIMITATIONS ON HOW LONG AN IMPLIED WARRANTY LASTS, SO THE ABOVE LIMITATION MAY NOT APPLY TO YOU.

JET SHALL IN NO EVENT BE LIABLE FOR DEATH, INJURIES TO PERSONS OR PROPERTY, OR FOR INCIDENTAL, CONTINGENT, SPECIAL, OR CONSEQUENTIAL DAMAGES ARISING FROM THE USE OF OUR PRODUCTS. SOME STATES DO NOT ALLOW THE EXCLUSION OR LIMITATION OF INCIDENTAL OR CONSEQUENTIAL DAMAGES, SO THE ABOVE LIMITATION OR EXCLUSION MAY NOT APPLY TO YOU.

JET sells through distributors only. The specifications listed in JET printed materials and on official JET website are given as general information and are not binding. JET reserves the right to effect at any time, without prior notice, those alterations to parts, fittings, and accessory equipment which they may deem necessary for any reason whatsoever. JET® branded products are not sold in Canada by JPW Industries, Inc.

### Product Listing with Warranty Period

90 Days – Parts; Consumable items
1 Year – Motors; Machine Accessories
2 Year – Metalworking Machinery; Electric Hoists, Electric Hoist Accessories; Woodworking Machinery used for industrial or commercial purposes
5 Year – Woodworking Machinery
Limited Lifetime – JET Parallel clamps; VOLT Series Electric Hoists; Manual Hoists; Manual Hoist Accessories; Shop Tools; Warehouse & Dock products; Hand Tools; Air Tools

NOTE: JET is a division of JPW Industries, Inc. References in this document to JET also apply to JPW Industries, Inc., or any of its successors in interest to the JET brand.

This page intentionally left blank.

This page intentionally left blank.

This page intentionally left blank.



427 New Sanford Road  
LaVergne, Tennessee 37086  
Phone: 800-274-6848  
[www.jettools.com](http://www.jettools.com)