

OWNER'S/OPERATOR'S MANUAL

WARNING:

Read this Manual, and any Supplements Carefully Before Operating Vehicle.

- Assembly
- Operation
- Maintenance

THIS VEHICLE IS NOT DESIGNED FOR USE ON RENTAL TRACKS OR RACING

XY450U

- BEFORE OPERATING THIS VEHICLE, THE OWNER AND EACH OPERATOR MUST HAVE READ AND HAVE AN UNDERSTANDING OF ALL THE INSTRUCTIONS FOR PROPER ASSEMBLY AND SAFE OPERATION, AS WELL AS THE INSTRUCTIONS CONCERNING THE ENGINE AND ALL OTHER PORTIONS OF THE VEHICLE.

CONTENTS

NOTE: A storage area/toolbox has been provided on the UTV for storage of this manual.
Please keep this manual in storage so that it can be found easily and referenced when needed.

- 1. INTRODUCTION 1.1
- 2. UNDERSTANDING WARNING 2.1
- 3. SAFETY WARNING 3.1
- 4. DAILY PRE-RIDE INSPECTION 4.1
- 5. OPERATION WARNING 5.1
- 6. V.I.N. NUMBER 6.1
- 7. CONTROL AND FUNCTIONS 7.1
- 8. STARTING THE ENGINE 8.1
- 9. BREAK-IN 9.1
- 10. RIDING WEAR 10.1
- 11. CARRYING LOADS 11.1
- 12. CVT SYSTEM 12.1
- 13. EXHAUST SYSTEM 13.1
- 14. BATTERY 14.1
- 15. TROUBLE SHOOTING 15.1
- 16. SPECIFICATION 16.1
- 17. ELECTRIC SCHEMATIC DIAGRAM 17.1
- 18. MAINTENANCE 18.1

1. INTRODUCTION

Introduction

Congratulations on the purchase of your Utility Task Vehicle (UTV). We take pride in offering you this product engineered and manufactured to the highest performance and quality standards. We are sure that you will enjoy superior levels of performance, reliability, riding comfort, and safety.

This manual is provided to help the owner and operators of this UTV become familiar with the operating characteristic, and the many features offered on the UTV. The manual also covers information on the care and maintenance of your UTV.

Please read this manual carefully. The information contained in this Owner's Manual, the Warning Labels supplied with this product will help you to understand the safe use and maintenance of your UTV. Make sure that you understand and follow all Warnings and Instructions in this material.

If you did not receive any of the material listed above, please call your dealer and request to have them sent to you.

Product and specifications are subject to change without notice.

1. INTRODUCTION

Important Safety Notice

- This vehicle is designed and manufactured for off-road use only. It is illegal to operate this vehicle on any public street, road, or highway. Such use is prohibited by law.
- Check the laws and regulations in force before choosing where to operate this vehicle. It is illegal to operate this vehicle on public lands where vehicles its size are prohibited.
- Never make any modifications to the engine, drive system, mechanical or electrical systems of your UTV. Never install aftermarket parts or accessories intended to increase the speed or power of your UTV.
- Failure to follow these warnings increases the possibility of accidents leading to **DEATH** or **SERIOUS INJURY!**
- Additionally, failure to follow these requirements will void the Warranty on your UTV.

NOTE

The addition and use of certain accessories including, (but not limited to) mowers, blades, sprayers, winches and windshields will change the handling characteristics and the performance of your UTV.

Practice Responsible UTV Riding

Make sure that you understand and follow all local, state/province, and federal/national riding laws and requirements.

Remember: Respect your vehicle, respect the environment and respect the property of others. You are responsible for your safety and the safety of others around you when you ride!

1. INTRODUCTION

A UTV CAN BE HAZARDOUS TO OPERATE.

A UTV handles differently from other vehicles including motorcycles, ATVs and cars. A collision rollover can occur quickly, even during routine maneuvers such as turning and driving on hills or over obstacles, if you fail to take proper precautions.



SERIOUS INJURY OR DEATH

can result if you do not follow these instructions.

- Read this manual and all labels carefully and follow the operating procedures described.
- This vehicle is designed to carry the driver and one passenger. Never carry passengers in the cargo bed.
- Always be sure the driver and passenger are wearing seat belts.
- Never allow anyone who is not an adult to operate this UTV.
- Never permit a guest to operate this UTV unless the guest has read this manual and all product labels.
- The driver and passenger must wear approved off-road motorcycle -type helmets that fits properly. The driver and passenger should also wear eye protections (glasses or face shields), gloves, boots, long-sleeved shirts or jackets, and long pants.
- As with any off-road-capable vehicle, there is a risk of tip over or rollover under certain conditions. Uneven terrain or slopes which pitch the vehicle sideways, turning too fast or sharp, or a combination of conditions increase the risk of tip over.
If you are in a situation where the vehicle is tipping over, do not put your arm or/ and leg outside the vehicle, do not try to stop tipping with your arm or leg. You could be severely injured. You could suffer a crushed hand, arm, leg, or foot, if part of your body is caught underneath the vehicle.
You must keep your arms and legs inside the vehicle until it has stopped moving.
- Never consume alcohol or drugs before or while operating this UTV.
- Never operate at excessive speeds. Always travel at a speed which is proper for the terrain, visibility and operating conditions, and your experience.
- Never attempt wheelies, jumps or other stunts.

1. INTRODUCTION

- Always inspect your UTV each time you use it to make sure it is in safe operating condition. Always follow the inspection and maintenance procedures and schedules described in this manual.
- Always keep both hands, arms, feet, and legs inside the vehicle at all times during operation. Keep your feet on the floorboard. Never hold onto the enclosure except when using the handgrip inside the enclosure. Otherwise, your hand could be injured if it is caught between the enclosure and an obstacle outside the vehicle.
- Always keep both hands on the steering wheel when driving.
- Never wrap your thumbs and fingers around the steering wheel. This is particularly important when driving in rough terrain. The front wheels will move right and left as they respond to the terrain, and this movement will be felt in the steering wheel. A sudden jolt could wrench the steering wheel around, and your thumbs or fingers could be injured if they are in the way of the steering wheel spokes.
- Always go slowly and be extra careful when operating on unfamiliar terrain. Always be alert to changing terrain conditions when operating the UTV.
- Never operate on excessively rough, slippery or loose terrain.
- Always follow proper procedures for turning as described in this manual. Practice turning at low speeds before attempting to turn at faster speeds. Do not turn at excessive speed.
- Always have the UTV checked by an authorized dealer if it has been involved in an accident.
- Never operate UTV on hills too steep for the UTV or for your abilities. Practice on smaller hills before attempting larger hills.
- Always follow proper procedures for climbing hills as described in this manual. Check the terrain carefully before you start up any hill. Never climb hills with excessively slippery or loose surfaces. Never open throttle suddenly or make sudden gear changes. Never go over the top of any hill at high speed.
- Always follow proper procedures for going down hills and for braking on hills as described in this manual. Check the terrain carefully before you start down any hill. Never go down a hill at high speed. Avoid going down a hill at an angle which would cause the vehicle to lean sharply to one side. Go straight down the hill where possible.
- Always follow proper procedures for crossing the side of a hill as described in this manual. Avoid hills with excessively slippery or

1. INTRODUCTION

loose surfaces. Never attempt to turn the UTV around on any hill. Avoid crossing the side of a steep hill if possible.

- Always use proper procedures if you stall or roll backwards when climbing a hill. To avoid stalling, maintain a steady speed when climbing a hill. If you stall or roll backwards, follow the special procedure for braking described in this manual.
- Always check for obstacles before operating in a new area. Never attempt to operate over large obstacles, such as large rocks or fallen trees. Always follow proper procedures when operating over obstacles as described in this manual.
- Always be careful of skidding or sliding. On slippery surfaces, such as ice, go slowly and be very cautious in order to reduce the chance of skidding or sliding out of control.
- Avoid operating the UTV through deep or fast flowing water. Avoid water which exceeds the recommended maximum depth. Go slowly, carefully avoiding sudden movements, maintain a slow and steady forward motion, do not make sudden turns or stops, and do not make sudden throttle changes.
- Wet brakes may have reduced stopping ability. Test your brakes after leaving water. If necessary apply them lightly several times to let friction dry out the pads.
- Always be sure there are no obstacles or people behind you when you operate in reverse. When it is safe to proceed in reverse, go slowly. Avoid turning at sharp angles in reverse.
- Always use the size and type tires specified in this manual. Always maintain proper tire pressure as described in this manual.
- Never modify A UTV through improper installation or use of accessories
- Never exceed the stated load capacity. Cargo should be as far forward in the bed as possible, and distributed evenly from side to side. Be sure cargo is secured so that it cannot move around during operation. Reduce speed and follow instructions in this manual for carrying cargo or pulling a trailer. Allow greater distance for braking.

2. UNDERSTANDING WARNINGS

ATTENTION:

This is an ADULT VEHICLE ONLY! Not a toy!
 READ AND UNDERSTAND WARNINGS AND OWNER'S MANUAL
 BEFORE OPERATION.



KNOW YOUR VEHICLE BEFORE YOU BEGING RIDING!

Read this manual thoroughly referring to the various areas which are being discussed on your machine. Operating this vehicle carries with it responsibilities for your personal safety, the safety of others, and the protection of our environment.

NOTE: Illustrations used in this manual are for general representation only. Your model may differ.

2. UNDERSTANDING WARNINGS

SAFETY ALERT

WARNINGS identify special instructions or procedures which, if not correctly followed, could result in personal injury, or loss of life. Read all **WARNINGS** in this manual carefully. Follow their instructions to remain safe.

The following precautionary signal words are used throughout this manual to convey the following messages:



This is the safety alert symbol. When you see this symbol on your machine or in this manual, be alert to the potential for personal injury. Your safety is involved!



WARNING

Indicates a potential hazard which could result in severe injury or death.



CAUTION

Indicates a potential hazard which may result in personal minor injury or damage to the UTV.

CAUTION

Indicates a situation that can result in damage to the machine.

NOTE The word "NOTE" in this manual will alert you to key information or instructions.

3. SFETY WARNING

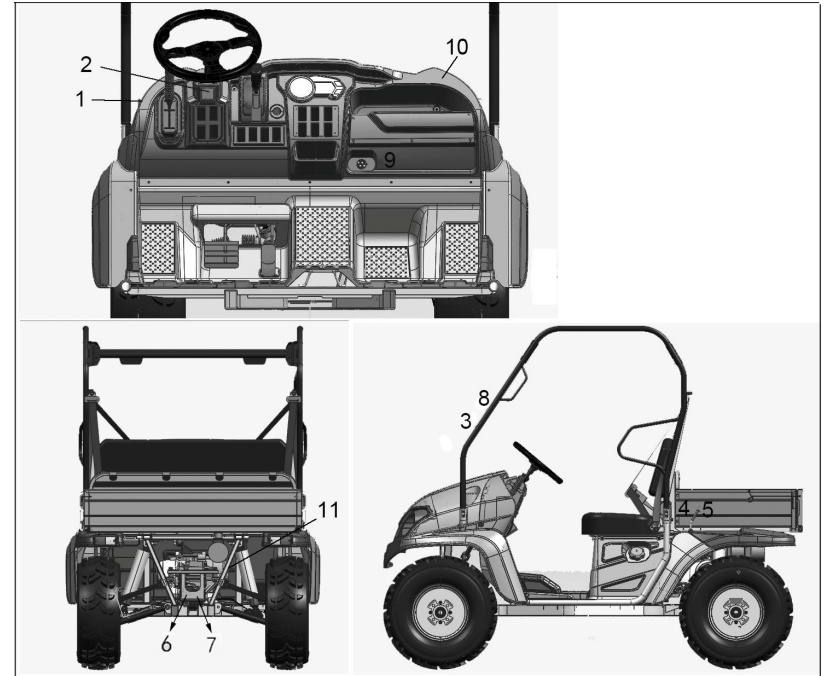

NOTE:

Warning decals have been placed on the vehicle for your protection. Read and follow the instructions on each decal carefully. In the event any decal becomes illegible or comes off, contact your dealer for a replacement.

3. SFETY WARNING

1

WARNING

Improper use can result in Server INJURY or DEATH

BE PREPARED

- Fasten seat belts.
- Wear an approved helmet and protective gear.
- Each rider must be able to sit with back against seat.

Feet flat on floor [and foot rests], and hands on steering wheel or handhold(s), [where equipped], Stay completely inside the vehicle.

Drive Responsibly

Avoid loss of control and rollovers:

- Avoid abrupt maneuvers, sideways sliding, skidding, or fishtailing, and never do donuts.
- Slow down before entering a turn.
- Plan for hills, rough terrain, ruts, and other changes in traction and terrain. Avoid paved surfaces.
- Avoid side hilling (ride across slopes).

Be Sure Riders Pay Attention and Plan Ahead if you think or feel the vehicle may tip or roll, reduce your risk to injury:

- Keep a firm grip on the steering wheel or handholds and brace yourself.
- Do not put any part or your body outside of the vehicle for any reason.

Require Proper Use of Your Vehicle Do you part to prevent injuries:

- Do not allow careless or reckless driving.
- Make sure operators are 16 or older with a valid driver's license.
- Do not let people drive or ride after using alcohol or drugs.
- Do not allow operation on public roads (unless designated for off-highway vehicle access)—collisions with cars and trucks can occur.
- Do not exceed seating capacity; 1 passenger.



ALWAYS USE AN APPROVED HELMET AND PROTECTIVE GEAR



NEVER USE PUBLIC ROADS OR PAVEMENT



NEVER USE WITH DRUGS OR ALCOHOL

[Locate and] Read [Owner's Manual]
Follow All Instruction and Warnings
[Reserved for Reference to Other Sources of Safety Information]

2

WARNING

IMPROPER TIRE PRESSURE OR OVERLOADING CAN CAUSE LOSS OF CONTROL. LOSS OF CONTROL CAN RESULT IN SERVER INJURY OR DEATH.

OPERATING TIRE PRESSURE: SET with tires cold. ALWAYS MAINTAIN PROPER TIRE PRESSURE AS INDICATED ON THE SIDEWALL OF YOUR VEHICLE TIRES.

NEVER set tire pressure below the recommended. Tire may dislodge from rim.

Gross Vehicle Weight Rating: 865kg (1907lbs) maximum including weight of operator, passenger, accessories, cargo, and (if applicable) trailer tongue weight.

3

WARNING

The enclosure cannot protect occupants in all foreseeable accidents, including rollover.

4

WARNING



- Keep hands, body, other persons away when closing bed.
- Do not operate the vehicle with bed up.

3. SFETY WARNING

5

WARNING

Severe INJURY or DEATH can result if you ignore the following:

- Maximum Load in Cargo Bed: 200kg (440lbs).
- Never carry passengers in cargo bed.
- Cargo can affect handling and stability.

Read Owner's Manual before loading or towing.

- When loading with cargo or towing a trailer: Reduce speed and allow more room to stop. Avoid hills and rough terrain.
- Be sure cargo is secured a loose load could change handling unexpectedly.
- Keep weight in the cargo bed centered, and as low and far forward as possible. Top heavy loads increase the risk of overturn.

6

WARNING

Pulling excessive loads can cause loss of stability or control of the vehicle.

Do not exceed the load capacity for the hitch.

Trailer Load Capacity of this vehicle is 450lbs /200kg and 25lbs/ 11 kg tongue weight.

7

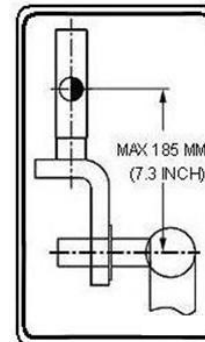

3. SFETY WARNING

8

| | |
|---|---|
| ⚠ WARNING | |
|  | <p>You could be severely injured if you try to stop a vehicle tip over using your arm or leg. If vehicle starts to tip over, keep arms and legs inside vehicle.</p> <p>Slopes, uneven terrain, and turning too fast or sharp increase the risk of tip over.</p> |

| | |
|---|---|
| ⚠ WARNING | |
|  | <p>You could be severely injured if you try to stop a vehicle tip over using your arm or leg. If vehicle starts to tip over, keep arms and legs inside vehicle.</p> <p>Slopes, uneven terrain, and turning too fast or sharp increase the risk of tip over.</p> |

9

| | |
|--|----------------|
|  | WARNING |
| <ul style="list-style-type: none"> • This socket only for accessory power • Maximum wattage 100w. • Not for cigarette lighter use | |

10

| | |
|---|----------------|
|  | WARNING |
| <ul style="list-style-type: none"> • Turn speed not to exceed 45MPH/72KPH • Do not drive in the water deeper than 13- inch. | |

11

| | |
|--|----------------|
|  | WARNING |
| <p>Inspect or replace oil, after waiting for the exhaust cooling to prevent burns.</p> | |

4. DAILY PRE-RIDE INSPECTION

| | |
|---|----------------|
|  | WARNING |
|---|----------------|

You must inspect your UTV each time before riding to ensure it is in proper working order. If proper inspection is not done, injury or death could result.

Use the following checklist to verify your machine is in proper working order each time you ride.

ITEM/ INSPECTION PROCEDURE

1, Tire— check condition and pressures.

2, Fuel tank— checking for leaking, fill the fuel tank to its proper level.

3, All brakes — check fluid level, check operation, adjustment (includes parking brake).

● Brake pedal

Check for correct brake pedal free play. If the brake pedal free play is incorrect, have an authorized dealer adjust it. Check the operation of the brake pedal. It should move smoothly and there should be a firm feeling when the brakes are applied. If not, have the vehicle inspected by your dealer.

● Brake fluid leakage

Check to see if any brake fluid is leaking out of the pipe joints or the brake fluid reservoir. Apply the brakes firmly for one minute. If there is any leakage, have the vehicle inspected by an authorized dealer.

Brake fluid level

● Check the brake fluid level.

Add fluid if necessary.

● Brake operation

Test the brakes at slow speed after starting out to make sure they are working properly. If the brakes do not provide proper braking performance, inspect the brake system.

4, Throttle/ Accelerator pedal— check for free operation, closing and freeplay.

Check to see that the accelerator pedal operates correctly. It must operate smoothly and fully spring back to the idle position when

4. DAILY PRE-RIDE INSPECTION

released.

Have an authorized dealer repair as necessary for proper operation.

5, Headlight / Taillight / Brake light— check operation of all indicator lights and switches.

6, Engine stop switch— check for proper function.

7, Wheels— check for tightness of wheel nuts and axle nuts; check those axle nuts are secured by cotter pins.

Check balance/ damage/ runout. Have an authorized dealer repair/ replace if necessary.

Check bearing assemblies for looseness/damage. Have an authorized dealer replace if damaged.

8, Air cleaner element— check for dirt; clean or replace.

9, Steering— check for free operation noting any unusual looseness in any area.

Park on level ground. Turn the steering wheel right and left. Check for excessive free play, abnormal noises, or a rough feeling. Have an authorized dealer repair as necessary for proper operation.

10, Loose parts— visually inspect vehicle for any damaged components or loose nuts/bolts or fasteners.

Always check the tightness of chassis fittings and fasteners before a ride. Take the vehicle to your dealer for correct tightening torque.

11, Operator's and passenger's helmets, goggles and clothing.

12, Engine coolant— check for proper level at the recovery bottle.

13, Seat belts— Check for proper operation and belt wear.

Make sure that both seat belts are not frayed or damaged. The seat belt must move smoothly when pulled out and retract on its own when released. The latch plate should click securely into the buckle and release when the release button is pushed firmly. Clean off any dirt or mud which could affect operation. Have an authorized dealer repair as necessary for proper operation.

5. OPERATION WARNINGS



WARNING

POTENTIAL HAZARD

Malfunction of the accelerator pedal.

WHAT CAN HAPPEN

The accelerator pedal could be hard to operate, making it difficult to speed up or slow down when you need . This could cause an accident.

HOW TO AVOID THE HAZARD

Check the operation of the accelerator pedal before you start the engine. If it does not work smoothly, check for the cause. Correct the problem before operating the vehicle. Consult an authorized dealer if you can't find or solve the problem yourself.



WARNING

POTENTIAL HAZARD

Not wearing the seat belt.

Wearing the seat belt improperly.

WHAT CAN HAPPEN

There is increased risk of being killed or seriously injured in an accident.

HOW TO AVOID THE HAZARD

Always wear your seat belt when riding in the vehicle.

Be sure the seat belt is close-fitting across your hips and chest and is latched securely.



WARNING

POTENTIAL HAZARD

Try to stop the tipping vehicle with your arm or leg.

WHAT CAN HAPPEN

You could be severely injured. You could suffer a crushed hand, arm, leg, or foot,

HOW TO AVOID THE HAZARD

You must keep your arms and legs inside the vehicle until it has stopped moving.

If you are in a situation where the vehicle is tipping over, do not put your arm or/ and leg outside, do not try to stop tipping with your arm or leg. You could be severely injured. You could suffer a crushed hand, arm, leg, or foot, if part of your body is caught underneath the vehicle.

5. OPERATION WARNINGS



WARNING

POTENTIAL HAZARD

Pinch points.

WHAT CAN HAPPEN

You or someone else could be pinched between the cargo bed and the frame when the bed is being lowered.

HOW TO AVOID THE HAZARD

Before closing the bed, be sure others are standing away from the vehicle. Keep hands and fingers away from the pinch points between the bed and the frame.



WARNING

POTENTIAL HAZARD

Overloading the cargo bed

WHAT CAN HAPPEN

Could cause changes in vehicle handling which could lead to an accident.

HOW TO AVOID THE HAZARD

Never exceed the stated maximum load limit for this cargo bed. Cargo should be properly distributed and securely attached. Reduce speed when carrying cargo. Allow greater distance for braking.



WARNING

POTENTIAL HAZARD

Carrying a passenger/ passengers in the cargo bed

WHAT CAN HAPPEN

The passenger(s) could fall, be thrown out, or be struck by objects in the cargo bed.

HOW TO AVOID THE HAZARD

Never carry a passenger/ passengers in the cargo bed. This cargo bed is designed to carry cargo only.



WARNING

5. OPERATION WARNINGS

POTENTIAL HAZARD

Driving with improperly operating brakes.

WHAT CAN HAPPEN

You could lose braking ability, which could lead to an accident.

HOW TO AVOID THE HAZARD

Always check the brakes before every ride. Do not operate the vehicle if you find any problem with the brakes. If a problem cannot be corrected by the adjustment procedures provided in this manual, have the vehicle inspected by an authorized dealer.



WARNING

POTENTIAL HAZARD

Operating vehicle without being familiar with all controls.

WHAT CAN HAPPEN

Loss of control, which could cause an accident or injury.

HOW TO AVOID THE HAZARD

Read the Owner's Manual carefully. If there is a control or function you do not understand, ask our authorized dealer.



WARNING

POTENTIAL HAZARD

Overloading this vehicle or carrying or towing cargo improperly.

WHAT CAN HAPPEN

Could cause changes in vehicle handling which could lead to an accident.

HOW TO AVOID THE HAZARD

Never exceed the stated load capacity for this vehicle. Cargo should be properly distributed and securely attached. Reduce speed when carrying cargo or pulling a trailer. Allow greater distance for braking.



WARNING

POTENTIAL HAZARD

Operating this vehicle with improper modifications.

WHAT CAN HAPPEN

5. OPERATION WARNINGS

Improper installation of accessories or modification of this vehicle may cause changes in handling which in some situations could lead to an accident.

HOW TO AVOID THE HAZARD

Never modify this vehicle through improper installation or use of accessories. All parts and accessories added to this vehicle should be genuine parts or equivalent components designed for use on this vehicle and should be installed and used according to instructions. If you have questions, consult an authorized dealer.



WARNING

POTENTIAL HAZARD

Operating/ riding this UTV without wearing an approved helmet, eye protection and protective clothing.

WHAT CAN HAPPEN

Operating/ riding without an approved helmet increases your chances of a severe head injury or death in the event of an accident.

Operating/ riding without eye protection can result in an accident and increases your chances of a severe injury in the event of an accident.

HOW TO AVOID THE HAZARD

Always wear an approved helmet which fits properly.

You should also wear eye protection (goggles or face shield); gloves; boots; long-sleeved shirt or jacket; and long pants.



WARNING

POTENTIAL HAZARD

Operating this UTV after drinking alcohol or edibling drugs.

WHAT CAN HAPPEN

Could seriously affect your judgment.

Could cause you to react more slowly.

Could affect your balance and perception.

Could result in an accident.

HOW TO AVOID THE HAZARD

Never drink alcohol or edible drugs before or while driving this UTV.



WARNING

5. OPERATION WARNINGS

POTENTIAL HAZARD

Operating this UTV at excessive speeds.

WHAT CAN HAPPEN

Increases your chances of losing control of the UTV, which can result in an accident.

HOW TO AVOID THE HAZARD

Always travel at a speed which is proper for the terrain, visibility and operating conditions; and your experience.



WARNING

POTENTIAL HAZARD

Failure to inspect the UTV before operating.

Failure to properly maintain the UTV.

WHAT CAN HAPPEN

Increases the possibility of an accident or equipment damage.

HOW TO AVOID THE HAZARD

Always inspect your UTV each time you use it to make sure the UTV is in safe operating condition.

Always follow the inspection and maintenance procedures and schedules described in the Owner's Manual.



WARNING

POTENTIAL HAZARD

Removing hands from steering wheel or feet from footrests during operation.

WHAT CAN HAPPEN

Removing even one hand or foot can reduce your ability to control the UTV or could cause you to lose your balance and fall off the UTV.

HOW TO AVOID THE HAZARD

Always keep both hands on the steering wheel and both feet on the footrests of your UTV during operation.



WARNING

POTENTIAL HAZARD

Failure to use extra care when operating this UTV on unfamiliar terrain.

WHAT CAN HAPPEN

You can come upon hidden rocks, bumps, or holes, without enough

5. OPERATION WARNINGS

time to react.

Could result in the UTV overturning or going out of control.

HOW TO AVOID THE HAZARD

Go slowly and be extra careful when operating on unfamiliar terrain.

Always be alert to changing terrain conditions when operating the UTV.



WARNING

POTENTIAL HAZARD

Failure to use extra care when operating on excessively rough, slippery or loose terrain.

WHAT CAN HAPPEN

Could cause loss of traction or vehicle control, which could result in an accident, including an overturn.

HOW TO AVOID THE HAZARD

Do not operate on excessively rough, slippery or loose terrain until you have learned and practiced the skills necessary to control the UTV on such terrain.

Always be especially cautious on these kinds of terrain.



WARNING

POTENTIAL HAZARD

Turning improperly.

WHAT CAN HAPPEN

UTV could go out of control, causing a collision or overturn.

HOW TO AVOID THE HAZARD

Always follow proper procedures for turning as described in the Owner's Manual.

Practice turning at low speeds before attempting to turn at faster speeds.

Do not turn at excessive speed.

Never operate UTV on hills steeper than 15%.



WARNING

POTENTIAL HAZARD

Improperly operating over obstacles.

WHAT CAN HAPPEN

Could cause loss of control or a collision. Could cause the UTV to

5. OPERATION WARNINGS

overturn.

HOW TO AVOID THE HAZARD

Before operating in a new area, check for obstacles.

Use extreme caution when riding over large obstacles, such as large rocks or fallen trees.

If you cannot avoid obstacles, always follow proper procedures as described in the Owner's Manual.



WARNING

POTENTIAL HAZARD

Skidding or sliding,

WHAT CAN HAPPEN

You may lose control of the UTV.

You may also regain traction unexpectedly, which may cause the UTV to overturn.

HOW TO AVOID THE HAZARD

On slippery surfaces, such as ice, go slowly and be very cautious in order to reduce the chance of skidding or sliding out of control.



WARNING

POTENTIAL HAZARD

Operating this UTV through deep or fast flowing water.

WHAT CAN HAPPEN

May cause the electric motor or the cable short circuit, or the vehicle out of control, which could lead to an accident

HOW TO AVOID THE HAZARD

Never operating the UTV through water which exceeds the recommended maximum depth in this manual.



WARNING

POTENTIAL HAZARD

Operating this UTV with improper tires, or with improper or uneven tire pressure.

WHAT CAN HAPPEN

Use of improper tires on this UTV, or operation of this UTV with improper or uneven tier pressure, may cause loss of control, and

5. OPERATION WARNINGS

increases the risk of an accident.

HOW TO AVOID THE HAZARD

Always use the size and type ties specified in the Owner's Manual for this vehicle.

Always maintain proper tire pressure as described in the Owner's Manual.



WARNING

After a rollover or an accident, have a qualified service dealer check the complete machine including, but not limited to, brakes, throttle and steering for possible damage.



CAUTION

Keep combustible materials away from exhaust system. Fire may result.

6. V.I.N., ENGINE SERIAL NUMBER AND KEY

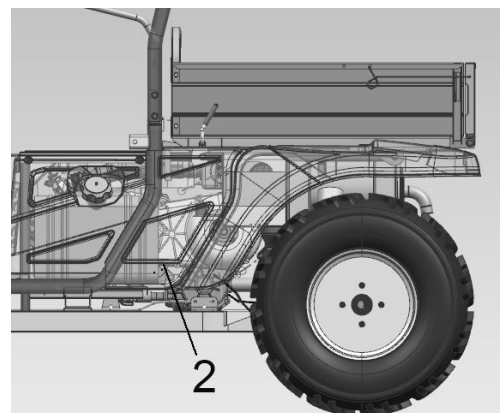
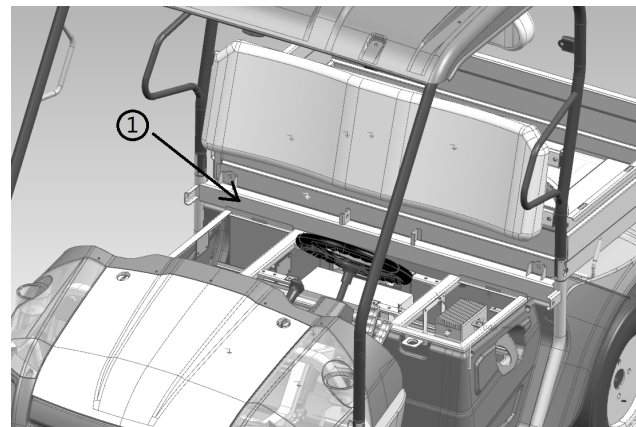

Record these numbers in the graphical position

1. Frame VIN (On the right side of the square tube after is located in the seat cushion)

| | | | | | | | | | | | | | | | |
|--|--|--|--|--|--|--|--|--|--|--|--|--|--|--|--|
| | | | | | | | | | | | | | | | |
|--|--|--|--|--|--|--|--|--|--|--|--|--|--|--|--|

2. Engine Serial Number (Left side of engine crankcase)

7. CONTROL AND PARTS FUNCTIONS

ELECTRICAL SWITCHES

Switch On Panel (U.S.)

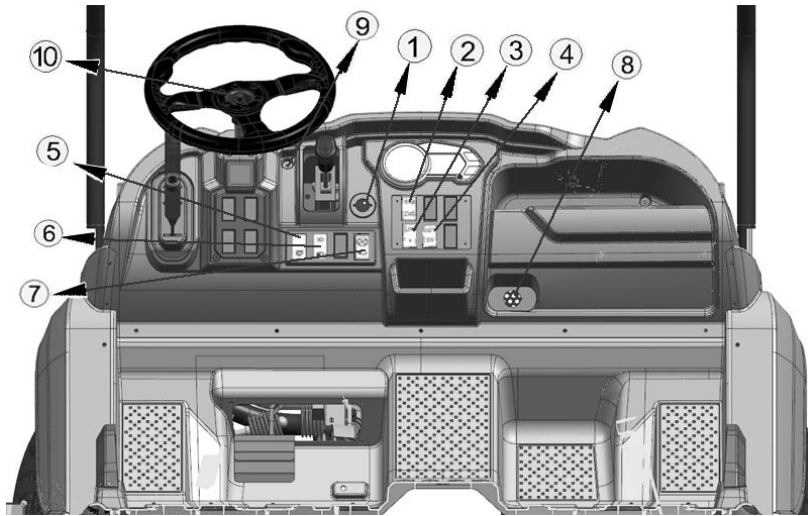

- 1, Main Switch 2, 4WD Switch 3, Differential Lock Switch 4, Traction Switch 5, Light Switch 6, Hi/ Lo Beam Switch 7, Emergency stop 8, Accessory Sock 9, Neutral Lamp 10, Horn

Functions of the respective switch positions are as follows:

ON: All electrical circuits are supplied with power.

OFF: All electrical circuits are switched off. The key can be removed in this position.

START: The electric starter is engaged by turning and holding the key in this position. Release the key when the engine starts.



CAUTION

Do not operate the electric starter continuously for more than 5 seconds, or starter damage could occur. Wait at least 5 seconds between each operation of the electric starter to let it cool.

Do not turn the key to the "START" position with the engine running, or damage to the electric starter can result.

7. CONTROL AND PARTS FUNCTIONS

- 1, Main Switch--The vehicle power supply switch.
- 2, 4WD Switch--Change condition of vehicle to 4WD or 2WD.
- 3, Differential Lock Switch--For controlling the rear differential, rear differential lock does not work when locking.
- 4, Traction Switch--For controlling the tractor reversing.
- 5, Light Switch --Turn on the headlight, rear position lights and LCD Meter backlight.
- 6, Hi/ Lo Beam Switch --Shift the high and low beam of headlight.
- 7, Emergency stop --Shut down engine when emergency happens.
- 8, See "Accessory Socket".
- 9, Neutral Lamp--Used for indicate the neutral position.
- 10, Horn--Switch for horn.

LCD Meter

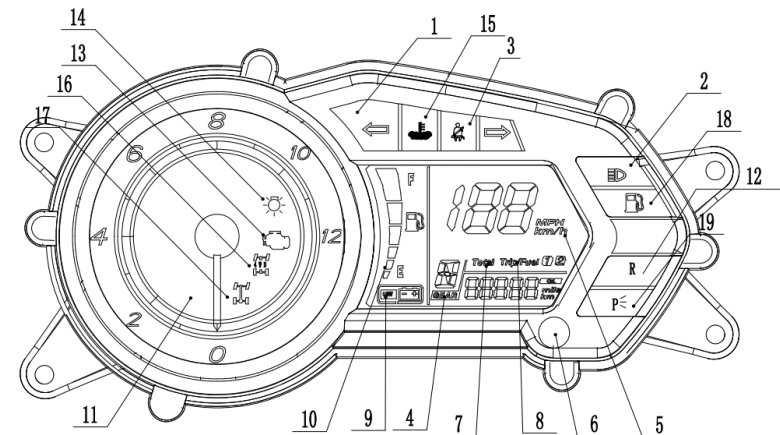

- | | |
|------------------------------|-----------------------------|
| 1. Left turn signal lamp | 7. The odometer |
| 2. High beam indicator light | 8. Trip/ Total selector |
| 3. Safe belt indicator | 9. Battery alarm indicator |
| 4. LCD show | 10. Oil position show |
| 5. Km/h/ mile/h selector | 11. Engine rpm meter |
| 6. Function button | 12. Reverse indicator light |

7. CONTROL AND PARTS FUNCTIONS

- | | |
|---|---------------------------------|
| 13. Electric fuel injection failure alarm indicator | 16. 4WD indicator |
| 14. Lamp switch indicator | 17. Differential lock indicator |
| 15. Water temperature alarm indicator | |

INSTRUMENT FUNCTION BUTTON IN DETAIL:

1. In open the electric door lock, electricity self-inspection on the meter state, long press the button more than 5 seconds to switch km or miles.
2. In the instrument working status, gently press the button can switch display trip mileage or total mileage.
3. In show the trip mileage state, long press the button more than 3 seconds to clear the mileage value.

Caution: Electric fuel injection failure alarm indicator should be lit, when open the key switch but did not start the engine, to prompt the alarm function is normal. After the engine starting, the lamp shall be put out, otherwise the efi system is faulty.

ACCESSORY SOCKET

The accessory socket (1) is attached to the left side of the front cover. You can use the accessory socket to power a trouble light, spotlight, CB radio, or cell phone etc.

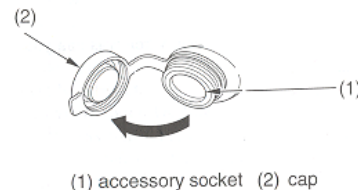

(1) accessory socket (2) cap



CAUTION

Do not plug in any heat-generating accessory such as an automobile cigarette lighter because it damages the socket.

To use the accessory socket, start the engine. Then turn the headlights OFF, and open the accessory socket cap (2).

Be sure the engine is on and the headlights are turned off before using the accessory socket, otherwise you may drain the battery.

The accessory socket is rated capacity is DC 12V. 120 Watts (10A) or less. If you exceed this limit, you may blow a fuse.

7. CONTROL AND PARTS FUNCTIONS

When you are done using an accessory, unplug it, and cover the socket with the cap.

Be careful not to flood this accessory socket when washing your UTV.

ACCELERATOR PEDAL



WARNING

Before starting the engine, check the accelerator pedal to be sure it is operating smoothly.

Make sure the accelerator pedal fully returns to the idle position as soon as it is released.

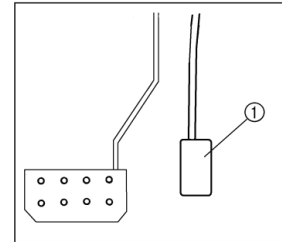

1. Accelerator pedal

Press the accelerator pedal down to increase engine speed. Spring pressure returns the pedal to the rest position when released. Always check that the accelerator pedal returns normally before starting the engine.



WARNING

POTENTIAL HAZARD

Malfunction of the accelerator pedal.

WHAT CAN HAPPEN

The accelerator pedal could be hard to operate, making it difficult to speed up or slow down when you need to. This could cause an accident.

HOW TO AVOID THE HAZARD

Check the operation of the accelerator pedal before you start the engine. If it does not work smoothly, check for the cause. Correct the problem before operating the vehicle. Consult the authorized dealer if you can't find or solve the problem yourself.

7. CONTROL AND PARTS FUNCTIONS

BRAKE PEDAL

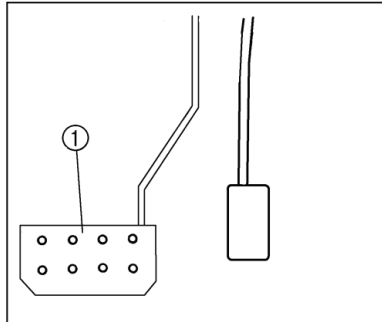

1.Brake pedal

Press the brake pedal to slow or stop the vehicle.



WARNING

Never operate the UTV with a spongy feeling brake pedal. Operating the UTV with a spongy brake pedal can result in loss of braking. Loss of braking could cause an accident.

PARKING BRAKE LEVER

The parking brake lever is located at the left hand of the steering wheel . It will help hold the vehicle from moving while parked. To set the parking brake, pull the lever up completely. The parking indicator light will come on if the main switch is on. To release the parking brake, pull up on the lever, press the release button, and then push the lever all the way down. Be sure to fully release the parking brake before starting out. Failure to do so may result in poor performance and premature wearing of the parking brake and V-belt.

1. Release button
2. Parking brake lever

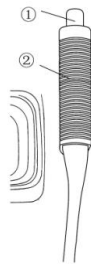

7. CONTROL AND PARTS FUNCTIONS

AUTOMATIC TRANSMISSION GEAR SELECTOR OPERATION

The transmission gear selector is located at the right side of the steering wheel The transmission selector lever has five positions: hight gear; low gear; neutral; reverse; packing brake.



CAUTION

To change gears, stop the vehicle and with the engine idling, move the lever to the desired gear. Shifting gears with the engine speed above idle or while the vehicle is moving could cause transmission damage.

Always place the transmission in gear with the parking brake locked whenever the vehicle is left unattended.

Maintaining shift linkage adjustment is important to assure proper transmission function. Should you experience any shifting problem see your dealer.

FUEL TANK CAP

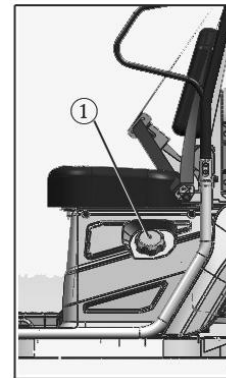

1.Fuel tank cap

Remove the fuel tank cap by turning it counterclockwise.

7. CONTROL AND PARTS FUNCTIONS

SEATS

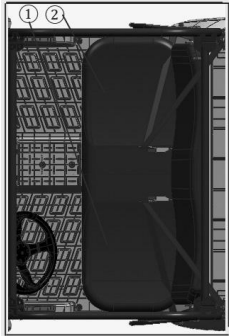

1. Drive seat
2. Passenger seat

To remove a seat, lift the front of the seat, and then slide the seat up and forward.

To install a seat, insert the projections on the rear of the seat into the seat holders and push down on the seat at the front.



WARNING

POTENTIAL HAZARD

A loose seat.

WHAT CAN HAPPEN

The operator could lose control or the operator or passenger could fall if the seat is loose during operation.

HOW TO AVOID THE HAZARD

Make sure the seat is securely latched.

SEAT BELTS

This vehicle is equipped with three-point seat belts for both the operator and passenger. Always wear the seat belt while riding in the vehicle.

7. CONTROL AND PARTS FUNCTIONS

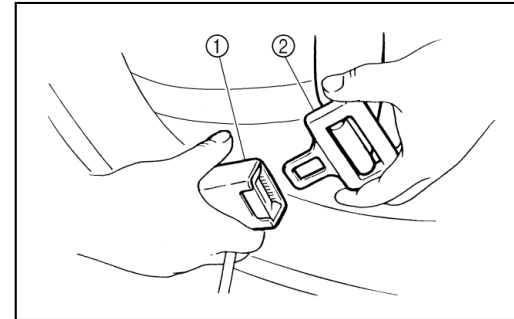

1. Buckle
2. Latch plate

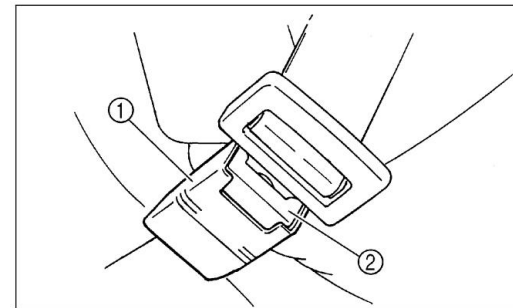

1. Buckle
2. Release button



CAUTION

To protect from damage, do not put metal products, like tools or sharply edged products directly in the glove compartment. If they must be stored, wrap them in appropriate cushion material.

7. CONTROL AND PARTS FUNCTIONS

CARGO BED

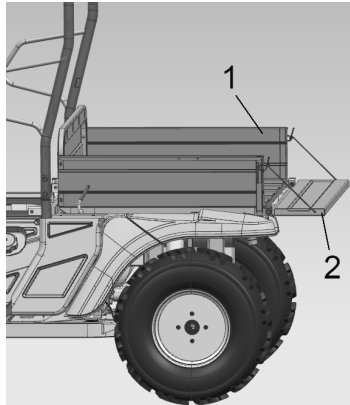

1. Cargo bed
2. Tailgate

Lifting And Lowering The Cargo Bed

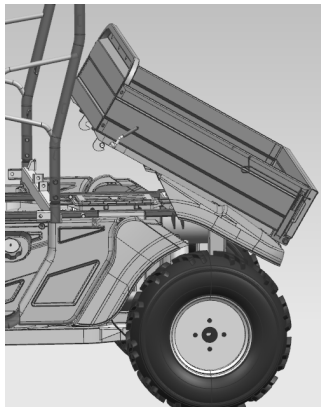

1. Cargo bed release lever

To lift

Push down the cargo bed release lever on the left or right side of the vehicle, and then slowly lift up the cargo bed until it stops.

To lower

Lower the cargo bed slowly to its original position and be sure that it is locked into place.

7. CONTROL AND PARTS FUNCTIONS



WARNING

POTENTIAL HAZARD

Carrying a passenger/ passengers in the cargo bed

WHAT CAN HAPPEN

The passenger(s) could fall, be thrown out, or be struck by objects in the cargo bed.

HOW TO AVOID THE HAZARD

Never carry a passenger/ passengers in the cargo bed. This cargo bed is designed to carry cargo only.

TRAILER HITCH BRACKET

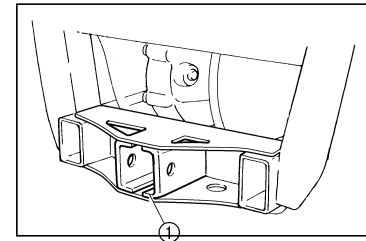

1. Trailer hitch bracket

This vehicle is equipped with a receiver bracket for a standard trailer hitch.

FUEL AND OIL SYSTEM



WARNING

Gasoline is highly flammable and explosive under certain conditions.

- Always exercise extreme caution whenever handling gasoline.
- Always refuel with the engine stopped and outdoors or in a well ventilated area.
- Do not smoke or allow open flames or sparks in or near the area where refueling is performed or where gasoline is stored.
- Do not over fill the tank. Do not fill the tank neck.
- If you get gasoline on your skin or clothing, immediately wash it off with soap and water and change clothing.
- Never start the engine or let it run in an enclosed area. Gasoline powered engine exhaust fumes are poisonous and can cause loss of consciousness and death in a short time.

7. CONTROL AND PARTS FUNCTIONS



WARNING

The engine exhaust from this product contains chemicals known, in certain quantities, to cause cancer, birth defects or other reproductive harm.

Recommended Fuel: Unleaded Gasoline Only

Fuel tank capacity: 18L

8. STARTING THE ENGINE

Procedure for Starting a Cold Engine



WARNING

Never run an engine in an enclosed area. Carbon monoxide exhaust gas is poisonous and can cause severe injury or death. Always start engines outdoors.



WARNING

POTENTIAL HAZARD

Freezing control cables in cold weather.

WHAT CAN HAPPEN

You could be unable to control the vehicle, which could lead to an accident or collision.

HOW TO AVOID THE HAZARD

When riding in cold weather, always make sure all control cables work smoothly before you begin riding.



CAUTION

You must allow your vehicle adequate warm up time before driving , otherwise it will damage the engine.

1. Apply the brake.
2. Shift the drive select lever into the neutral position.

NOTE: When the drive select lever is in the neutral position, the neutral indicator light should come on. If the neutral indicator light does not come on, ask a dealer to inspect the electric circuit.

The engine can be started in any gear if the brake is applied. However, it is still recommended to shift into neutral before starting the engine.

3. With your foot off the accelerator pedal, start the engine by turning

8. STARTING THE ENGINE

the key to "START".

NOTE: If the engine fails to start, release the key, and then try starting again. Wait a few seconds before the next attempt. Each cranking should be as short as possible to preserve battery energy. Do not crank the engine more than 5 seconds on each attempt.

Jump-starting

Jump-starting the vehicle should be avoided. The battery should be removed and charged instead. However, if the vehicle must be jump started, proceed as follows.

1. Turn the key to "OFF".
2. Connect the positive end of a full charged 12V battery to the positive end of battery in the car by using the jumper cable.

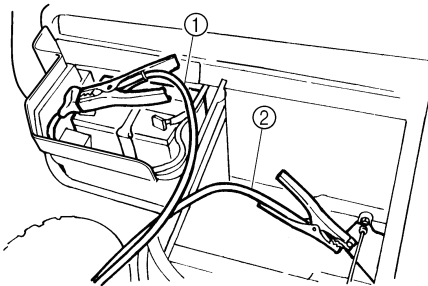

1. Jumper cable positive lead 2. Jumper cable negative lead

3. Connect the negative lead of the jumper cable to the negative terminal of the charged battery and the other end of the negative lead to an unpainted metal surface of the vehicle.
4. Open the key switch, apply the brake, turn the ignition key to starting stalls, start the engine.
5. After the engine starts, disconnect the negative lead of the jumper

8. STARTING THE ENGINE

cable from the vehicle and charged battery, and then disconnect the positive lead of the jumper cable from the charged battery and the battery in the vehicle.

9. VEHICLE BREAK-IN PERIOD

The break-in period for your new UTV is defined as the first 50 hours of operation. No single action on your part is as important as a proper break in period. Careful treatment of new engine will result in more efficient performance and longer life for the engine. Perform the following procedures carefully.



CAUTION

Do not operate at full throttle or high speeds for extended periods during the break-in period. Excessive heat can cause damage on engine related components.

1. Fill fuel tank.
2. Check oil reservoir level indicated on dipstick. Add oil if necessary.
3. Drive slowly at first. Select an area which is open and will give you room to familiarize yourself with vehicle operation and handling.
4. Vary the throttle positions. Do not operate at sustained idle.
5. Perform regular checks on oil reservoir level , controls all important areas on the vehicle according to the chapter of "PRE-RIDE".
6. Don't pull loads.
7. Please replace the engine oil and filter , after driving for 20 hours or 500 miles.

10. RIDING WEAR

Always wear clothing suite to the type of riding you are doing. UTV riding requires special protective clothing which will make you fell more comfortable and reduce chances of injury.

1. Helmet

Your helmet is the most important piece of protective gear for safe riding. Select an approved off-road motorcycle -type helmets that fits properly prevent a severe head injury.

2. Eye Protection

A pair of goggles or helmet face shield offer the best protection for your eyes.

3. Gloves (off-road style)

4. Boots

A pair of strong over the calf type boots with heels, such as motocross boots.

5. Clothing

To protect your body, long sleeves and pants should always be worn. Riding pants with kneepads, a jersey and shoulder pads provide the best protection.

10. RIDING WEAR



WARNING

POTENTIAL HAZARD

Operating this vehicle without wearing an approved motorcycle helmet, eye protection, and protective clothing.

WHAT CAN HAPPEN

Operating without an approved motorcycle helmet increases your chances of a severe head injury or death in the event of an accident.

Operating without eye protection can result in an accident and increases your chances of a severe injury in the event of an accident.

HOW TO AVOID THE HAZARD

Always wear an approved motorcycle helmet that fits properly. You should also wear: eye protection (goggles or face shield), gloves, boots, long-sleeved shirt or jacket long pants.

11. CARRYING LOADS

CARRYING LOADS

Cargo or a trailer can change the stability and handling of a vehicle.

You must use common sense and good judgment when carrying cargo or towing a trailer. Keep the following points in mind:

- Never exceed the weight limits shown. An overloaded vehicle can be unstable.

MAXIMUM LOADING LIMIT

Cargo bed: 200 kg (440 lb)

Trailer hitch:

Pulling load (total weight of trailer and cargo): 200 kgf (440 lbf)

Tongue weight (vertical weight on trailer hitch point): 11 kgf (25 lbf)

- Choose a trailer hitch drawbar designed for use with a 5 cm (2 in) receiver.
- Load cargo in the cargo bed as close to the center of the vehicle as possible and tie it down using the cargo hooks equipped on the cargo bed.
- Tie down cargo securely in the trailer. Make sure cargo in the trailer cannot move around. A shifting load can cause an accident.
- Make sure the load does not interfere with controls or your ability to see where you are going.
- Drive more slowly than you would without a load. The more weight you carry, the slower you should go. Although conditions vary, it is good practice not to exceed low range whenever you are carrying

11. CARRYING LOADS

heavier loads or when towing a trailer.

- Allow more braking distance. A heavier vehicle takes longer to stop.
- Avoid making sharp turns unless at very slow speeds.
- Avoid hills and rough terrain. Choose terrain carefully. Added weight affects the stability and handling of the vehicle.



WARNING

POTENTIAL HAZARD

Overloading this vehicle or carrying or towing cargo improperly.

WHAT CAN HAPPEN

Could cause changes in vehicle handling which could lead to an accident.

HOW TO AVOID THE HAZARD

Never exceed the stated load capacity for this vehicle. Cargo should be properly distributed and securely attached. Reduce speed when carrying cargo or pulling a trailer. Allow greater distance for braking.



WARNING

POTENTIAL HAZARD

Carrying a passenger in the cargo bed.

WHAT CAN HAPPEN

The passenger could fall or be struck by objects in the cargo bed.

HOW TO AVOID THE HAZARD

Never carry a passenger in the cargo bed. The cargo bed is designed to carry cargo only.

11. CARRYING LOADS

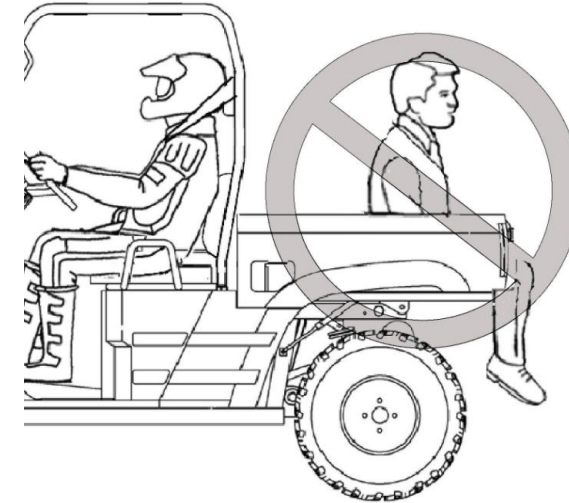

12. CVT SYSTEM



WARNING

The CVT system rotates at high speeds. Creating large amounts of force on clutch components.

Do not modify any components of the CVT system. Any modification will damage the system; and cause the system to be out of balance,

The CVT housing must be securely in place during operation,

Failure to comply with this warning can result in severe injury or death.

CVT SYSTEM

On UTV, the approximate gear ratio difference between high and low range is 1:2.2. This difference in gearing affects the operation of the CVT, especially at speeds less than 7 MPH, due to the system's dependence on engine speed.

13. EXHAUST SYSTEM

SYSTEM REGULATION

TAMPERING WITH NOISE CONTROL SYSTEM PROHIBITED!

CAUTION: Exhaust system components are very hot during and after use of UTV.

- Do not touch exhaust system components. Serious burns can result.
- Be especially careful when traveling through tall grass. The potential for fire exists

Spark Arrestor

The exhaust pipe must be periodically purged of accumulated carbon as follows:

1. Remove the arrestor screw ① located on the bottom of the muffler, pull out the arrestor (the mesh) ②.
2. Clean the arrestor or replace it.



WARNING

When cleaning the spark arrestor, you must follow the safe guards listed below to avoid serious injury.

- Do not perform this operation immediately after the engine has been run because the exhaust system becomes very hot.
 - Keep combustible materials away from exhaust system, otherwise may cause a fire.
-

13. EXHAUST SYSTEM

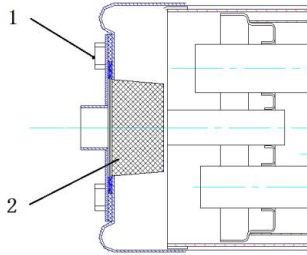

Catalyst

There is catalyst inside the muffler on all models .



WARNING

The engine rpm limiter will work at 7500rpm, this may cause excessive fuel to build in the exhaust, and ignited by the catalyst in the muffler, and could lead to a silencer overheating and the risk of fire.

Always reduce throttle when the engine reach top rpm, avoid the engine popping.



WARNING

The engine exhaust from this product contains chemicals known, in certain quantities, to cause cancer, birth defects or other reproductive harm.

14. BATTERY



WARNING

Whenever removing the battery, disconnect the negative (black) cable first. When reinstalling the battery, connect the negative (black) cable last or an explosive situation could result causing serious injury or death.



WARNING

Battery electrolyte is poisonous. It contains sulfuric acid. Serious burns can result from contact with skin, eyes or clothing. Antidote:

External: Flush with water.

Internal: Drink large quantities of water or milk. Follow with milk of magnesia, beaten egg, or vegetable oil. Call physician immediately.

Eyes: Flush with water for 15minutes and get prompt medical attention.

Batteries produce explosive gases. Keep sparks, flame, cigarettes, etc. away. Ventilate when charging or using in an enclosed space. Always shield eyes when working near batteries. **KEEP OUT OF REACH OF CHILDREN.**

Battery Removal

1. Disconnect hold down straps holding the electrical box and battery in position and remove battery cover.
2. Disconnect the black (negative) battery cable first.
3. Disconnect the red(positive) battery cable next.
4. Lift the battery out of the UTV.



CAUTION

If electrolyte spills, immediately wash it off with a solution of one tablespoon baking soda and one cup water to prevent damage to the UTV.

14. BATTERY

Battery Installation and Connections



WARNING

To avoid the possibility of explosion, always connect battery cables in the order specified. Red (positive) cable first; black (negative) cable last. An exploding battery can cause serious injury or death.



WARNING

Battery terminals and connections should be kept free of corrosion. If cleaning is necessary, remove the corrosion with a stiff wire brush. Wash with a solution of one tablespoon baking soda and one cup water. Rinse well with tap water and dry off with clean rags. Coat the terminals with dielectric grease or petroleum jelly. Be careful not to allow cleaning solution or tap water into the battery.

1. Set the battery in its holder.
2. First connect and tighten the red (positive) cable.
3. Second connect and tighten the black (negative) cable.
4. Reinstall battery cover and attach the hold down strap.
5. Verify that cables are properly routed.



CAUTION

Your UTV is equipped with a 30Ah Battery. This may not be sufficient to provide power for optional equipment. When installing optional equipment please upgrade your battery as necessary. See your dealer for the proper battery.

15. TROUBLESHOOTING

LOW BATTERY

| Possible Cause | Solutions |
|--|--|
| Starting a faulty engine for long time | See "8.STARTING THE ENGINE" And check the fuel/ air/ ignition/ compression system |
| Let the main switch (key) on while parking the UTV | When stopping the engine, turn off the main switch (key) off at once |



WARNING

This UTV equipped with an electric start system. If the battery is under charging, the UTV will not run.

15. TROUBLESHOOTING

NOTE:

The following troubleshooting does not cover all the possible causes of trouble. It should be helpful, however, as a guide to troubleshooting. Refer to the relative procedure in this manual for inspection, adjustment and replacement of parts. Adjustment and replacement must be done by your dealer.

STARTING FAILURE/ HARD STARTING

FUEL SYSTEM

Fuel tank

- Empty
- Clogged fuel tank breather hole
- Fuel pump is clogged
- Deteriorated fuel or fuel containing water or foreign material

Electric fuel injection

- ECU failure or wiring faulty
- Nozzle clogging or failure
- Throttle position sensor failure
- EFI relay does not work

COMPRESSION SYSTEM

Cylinder and cylinder head

- Loose spark plug
- Loose cylinder head
- Broken cylinder head gasket
- Broken cylinder gasket
- Worn, damaged or seized cylinder

Piston and Piston ring

- Worn piston
- Worn fatigued or broken piston ring
- Seized piston ring
- Seized or damaged piston

Valve system

- Improperly adjusted valve clearance
- Improperly sealed valve
- Improperly contacted valve and valve seat
- Improper valve timing
- Broken valve spring
- Seized valve

15. TROUBLESHOOTING

IGNITION SYSTEM

Battery

- Improperly charged battery
- Faulty battery

Fuse

- Burnt out, improper connection

Spark plug

- Improper plug gap
- Worn electrodes
- Wire between terminals broken
- Improper heat range
- Faulty spark plug cap

Ignition coil

- Broken or shorted primary/secondary coil
- Faulty high tension cord
- Broken ignition coil body

Ignition system

- Faulty ignitor unit
- Faulty pick up coil
- Broken magneto woodruff key
- Faulty main switch
- Faulty brake switch

Wiring

- Loose battery terminal
- Loose coupler connection
- Improperly grounded
- Broken wireharness

POOR IDLE SPEED PERFORMANCE

EFI

- Loose or clogged pilot jet
- Trigger coil gap inappropriate
- Ignition loop cable failure
- Improperly adjusted idle speed (Pilot screw), (Throttle stop screw)
- Improperly adjusted throttle cable
- Intake pressure temperature sensor failure

Air cleaner

- Clogged air cleaner element

Ignition system

- Faulty spark plug
- Faulty high tension cord
- Faulty ignition coil

Valve system

- Improperly adjusted

15. TROUBLESHOOTING

POOR MEDIUM AND HIGH SPEED PERFORMANCE

EFI

- Improperly adjusted fuel level element
- Clogged main nozzle
- Clogged or loose pilot jet

Air cleaner

- Clogged air cleaner

POOR SPEED PERFORMANCE

Ignition system

- Dirty spark plug
- Improper heat range
- EFI failure

Fuel system

- Clogged fuel tank breather hole
- Clogged air cleaner element
- Clogged jet
- Improperly adjusted fuel level
- Improper carburetor air vent hose setting

Compression system

- Worn cylinder
- Worn or seized piston ring
- Cylinder head gasket broken
- Cylinder gasket broken
- Carbon deposit buildup
- Improper adjusted valve clearance
- Improper contacted valve and valve seat
- Faulty valve timing

Clutch

- Refer to "CLUTCH SLIPPING /DRAGGING" section

Engine oil

- Improper oil level(low or over Oil level)

Ignition system

- Faulty spark plug

15. TROUBLESHOOTING

- Faulty high tension cord
- Faulty pick up coil
- Faulty ignition coil

Valve system

- Improperly adjusted valve clearance

OVER HEATING

Ignition system

- Improperly spark plug gap
- Improper spark plug heat rang

- Faulty igniter unit

Fuel system

- ECU setting incorrectly
- Improper fuel level adjustment
- Clogged air cleaner element

Compression system

- Heavy carbon deposit build-up
- Improperly adjusted valve timing
- Improperly adjusted valve clearance

Engine oil

- Incorrect engine oil level
- Improper engine oil quality (High viscosity)
- Low engine oil quality

Brakes

- Dragging brake

OVER-COOLING

Cooling system

- Faulty temperature switch
- Water temperature regulation set incorrectly

15. TROUBLESHOOTING

Cooling system

- Tank temperature sensor failure
- Water tank fan failure

FAULTY CLUTCH

WHEN ENGINE RUN, UTV DOES NOT RUN

V belt

- Worn/bent/slipping

Cam, slider

- Worn/damaged

Compression spring

- Damage

Gears

- Damage

CLUTCH SLIPPING

Clutch weight spring

Position

- Worn/loose

Clutch shoe

- Worn/ damaged

Primary sliding sheave

- Seized

POORSTARTING PERFORMANCE

V-belt

- Slipping/oily V-belt

Primary sliding sheave

- Improper operation

POOR SPEED PERFORMANCE

V-belt

- Worn

- Oil V belt

Roller weight

- Worn/improper operation
primary/secondary/sheave

- Worm

CVT SYSTEM

Uncorrect Primaty Clutch

- Uncorrect engine mount
(see 13. CVT system)

FAULTY BRAKE

POOR BRAKING EFFECT

- Worn front hub bearing

- Worn brake pad

- Worn brake disc

- Air in brake fluid

15. TROUBLESHOOTING

- Damage

compressing spring

- Worm/loose

Secondary sliding sheave

- Improper operation

- Worn guide pin grove

- Worn guide pin

Clutch shoe

- Worn/ bent

- Leaking brake fluid

- Faulty master cylinder kit

- Faulty caliper seal kit

- Loose union bolt

- Broken brake hose

- Oily or greasy brake pad

- Oily or greasy brake disc

16. SPECIFICATION

| Dimensions & Capacities | | | |
|--|------------------------|---------------------|------------------------|
| L X W X H | 2623X1480X1940 mm | | |
| Seat height | 470mm | | |
| Wheel Base | 1880mm | | |
| Ground Clearance | 260mm | | |
| Fuel capacity | 18L | | |
| Engine Oil Capacity | 1.3 L | | |
| Dry Weight | 515 kg | | |
| Load Capacity (Combined Rider& Payload) | 350 kg | | |
| Cargo Bed Maximum load limit | 200kg | | |
| Tongue Weight | 11 kg | | |
| Tow Capacity | 200 kg | | |
| Drive System | | | |
| Drive System | CVT | | |
| Front Tire | 25X8-12 | | |
| Rear Tire | 25X10-12 | | |
| Tire Pressure(front) | 100 kPa | | |
| Tire Pressure(rear) | 100 kPa | | |
| Brake System | | | |
| Brake | Front Brake | Dual Hydraulic Disc | Front and rear unified |
| | Rear Brake | | |
| | Operation | Foot | |
| Parking Brake | Mechanical Disc | | |
| Suspension | | | |
| Front | MacPherson Strut | | |
| Rear | Swing Arm | | |
| shock absorber | Coil spring/oil damper | | |

16. SPECIFICATION

| Engine | |
|--------------------|--|
| Engine Type | XY182MQ 4Stroke, Single Cylinder, SOHC |
| Bore x Stroke | 82mmx74mm |
| Displacement | 390.8cc |
| Starter System | Electric Starter |
| Engine Cooling | Liquid -Cooled |
| Lubrication System | Wet Sump |
| Ignitions | EFI |
| Spark Plug Type | DR8EA |

| Electrical Equipment | | | |
|-----------------------------|---------------------------------|--------|--------------------|
| Battery | 12V 30AH | | |
| Head light | 35W/35W x2 | | |
| Front Position Light | 12V 5W x2 | | |
| Rear Position Light | 12V 5/3W x2 | | |
| Brake/ Tail Light | 12V 10W x4 | | |
| Parking Light | 12V 1W | | |
| High Beam Indicator Light | 12V 1W | | |
| Neutral Indicator Light | 12V 1.7W | | |
| Reverse Indicator Light | 12V 1W | | |
| Specified fuses | Main Fuse | 25.0 A | On The Start Relay |
| | Backup Fuse | 25.0 A | |
| | Ignition System Fuse | 7.5 A | In The Fuse Box |
| | Accessory So cket Fuse | 10.0 A | |
| | Fan Fuse | 10.0 A | |
| | Signaling/ Lighting System Fuse | 20.0 A | |
| | Backup Fuse (1) | 10.0 A | |
| | Backup Fuse (2) | 20.0 A | |

17. WIRING DIAGRAM

| Code | Colour |
|------|--------------|
| R | Red/Red |
| B/R | Black/Red |
| L/G | Light Green |
| W | White |
| G/R | Green/Red |
| P/R | Pink/Red |
| G | Green |
| G/B | Green/Black |
| G/Y | Green/Yellow |
| Y/W | Yellow/White |
| B/W | Blue/White |
| R/B | Red/Black |
| B/Y | Blue/Yellow |
| B | Blue |
| O/G | Dark Green |
| B/R | Brown/Red |
| B/Y | Blue/Yellow |
| B/W | Blue/White |
| B/L | Black/Blue |
| Pu | Purple |
| Y/R | Yellow/Red |
| R/W | Red/White |
| G/R | Green/Red |
| G/W | Green/White |
| B/G | Black/Green |
| G/W | Gray/White |
| B/W | Black/White |
| B/R | Brown/Red |

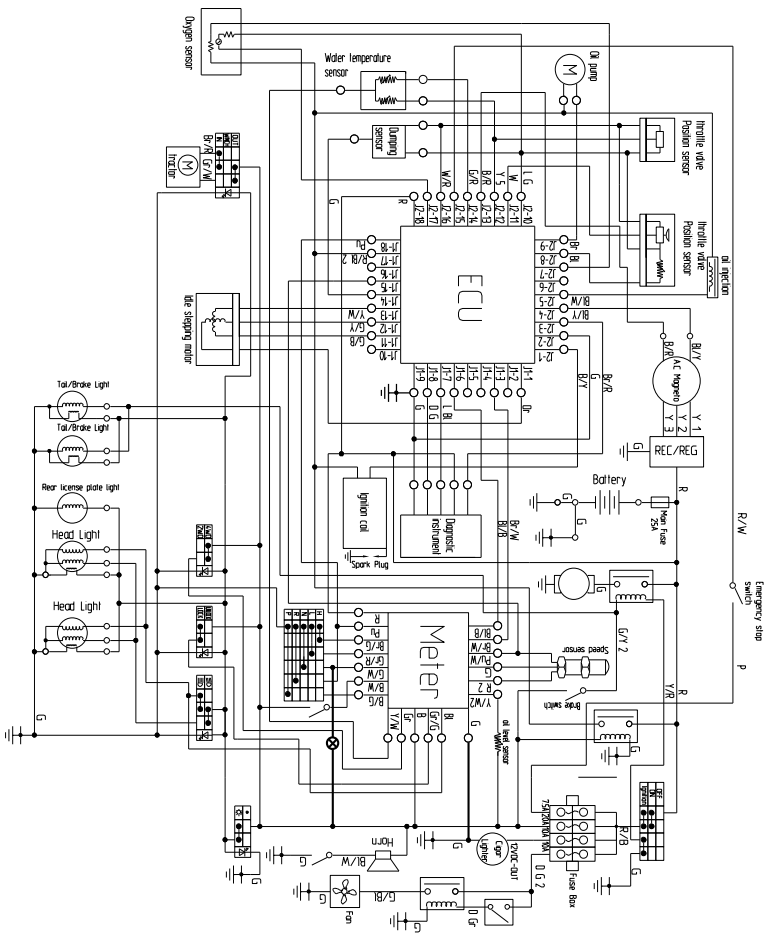

18. MAINTENANCE

To keep the performance good, the motorcycle should be checked and maintained at certain interval. The meanings of capital in following table are:

I: Inspection, including check, clean, lubricate, refuel, repair or replacing if necessary.

A: Adjusting C: Cleaning R: Replacing T: Tightening

| Maintenance e period | Odometer (km) | | | | | | | | | | | | | | | | | | | |
|---|---------------|-----|------|------|------|---|------|------|------|------|------|-------|-------|-------|-------|-------|-------|--------------|--|--|
| | Items | 300 | 1000 | 2000 | 3000 | 4000 | 5000 | 6000 | 7000 | 8000 | 9000 | 10000 | 11000 | 12000 | 13000 | 14000 | 15000 | check before | | |
| Crankcase lube | R | R | R | R | R | R | R | R | R | R | R | R | R | R | R | R | R | I | | |
| Lube filter | C | | | | C | | | | | C | | | | | | | | | | |
| Air filter | | | | | | Clean filter every 2000~3000 km. change it when necessary | | | | | | | | | | | | | | |
| Spark plug | | | | | | | | | | | | | | | | | | | | |
| Valve gap | | | | | A | | | | A | | | | | | | | | | | |
| Gas filter | | | | | | | | | R | | | | | | | | | | | |
| Brake function, brake pads | I | I | I | I | I | I | I | I | I | I | I | I | I | I | I | I | I | I | | |
| Brake fluid | | | | | | | | | | | | | | | | | | | | |
| Driving chain | | | | | | | | | | | | | | | | | | I | | |
| Excluding Engine | T | | | | | | | | | | | | | | | | | | | |
| Engine Bolt | | | | | | | | | | | | | | | | | | | | |
| Initial 4000km and Clean every 3000~4000km change it when necessary | | | | | | | | | | | | | | | | | | | | |

18. MAINTENANCE

The following items should be checked occasionally for tightness; or if they have been loosened for maintenance service.

WHEEL NUT TORQUE SPECIFICATIONS

| Bolt Size | Specification | |
|-----------|---------------|-------|
| M12X1.25 | 50Ft.Lbs | 69N.m |

NOTE: All nuts that have a cotter pin installed must be serviced by an authorized Dealer.

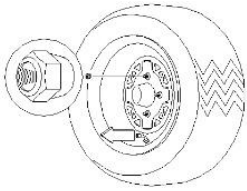

AXLE BOOTS

- Front Shaft Boots,
- Rear Axle (CV Joints,) Boots,

Check the protective boots for holes or tears. If any damage is found, have them replaced by an authorized dealer.

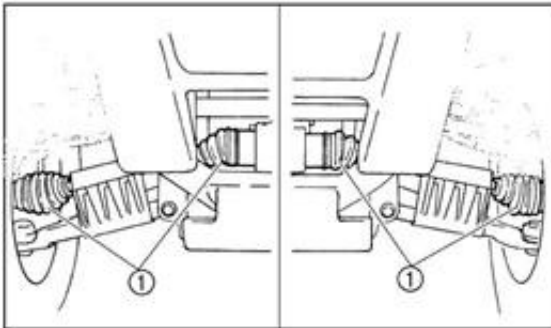

18. MAINTENANCE

REAR SPRING ADJUSTMENT

The rear shock absorber spring is adjusted by rotating the adjuster in the direction required to increase or decrease spring tension.

Rear Spring Adjustment

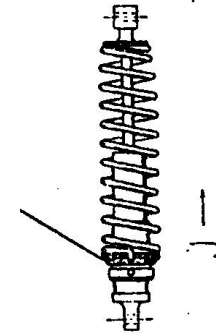

AIR FILTER SERVICE

1. Lift the cargo bed. (See 7. CONTROL AND PARTS FUNCTIONS in this manual for bed lifting and lowering.)
2. Release clips and remove Cover.
3. Loosen clamp and remove Filter.
4. Remove fabric type pre-filter from main filter. Wash pre-filter in soapy water and dry it.
5. Reinstall pre-filter over main filter. Replace main filter as required.
6. Reinstall filter into air box and tighten clamp. Do not over tighten clamp, Otherwise filter damage may occur.

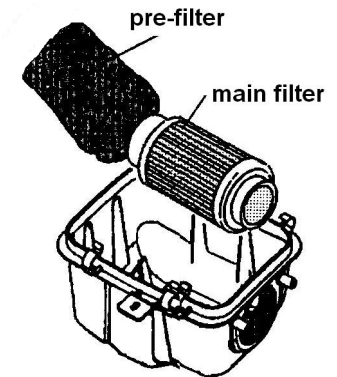

STEERING

Steering Inspection

The steering assembly of the machine should be checked periodically for loose nuts and bolts, worn tie rod ends, worn boots, and damage. Checking routing of all cables, hoses, and wiring to be sure the steering

18. MAINTENANCE

mechanism is not restricted or limited. If any found, have your dealer repair them before riding your vehicle.

The steering assembly should be also checked periodically for free operation, steering should move freely through entire range of travel without binding. Park on level ground. Turn the steering wheel right and left. Check for excessive free play, abnormal noises, or a rough feeling. Have an authorized dealer repair as necessary for proper operation.

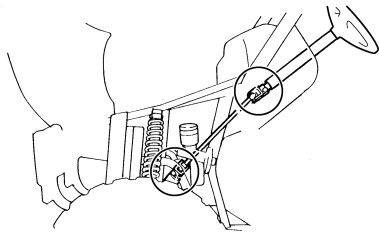

Lubricate the pivoting parts.

Recommended lubricant:

Lithium-soap-based grease

CAMBER AND CASTER

The camber and caster are non-adjustable.

TOE ALIGNMENT CHECK



WARNING

Do not attempt to adjust the tie rod for toe alignment. Severe injury or death can result from improper adjustment.

Contact your dealer. He/she has the training and tools to Make these adjustment.

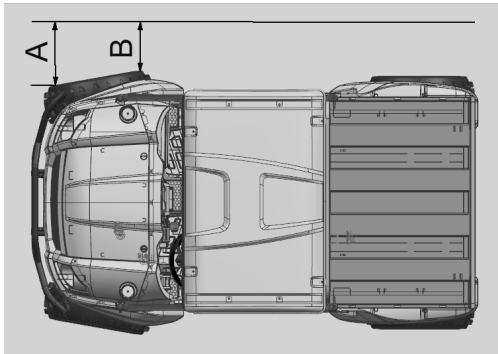

The recommended toe alignment is 1/8" to 1/4" (3 to 6mm) toe out.

1. Set the steering wheel in a straight ahead position and hold them in this position.
2. Measure A and B, A minus B should be 1/8" to 1/4" (3 to 6mm).

18. MAINTENANCE

3. If this measurement needs to be adjusted, contact your dealer for service.



WARNING

If the tie rod is positioned incorrectly or adjusted incorrectly, it will not pivot, may break, and may separate. Severe injury or death can result

Hold Rod End

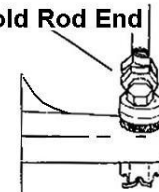

**Correctly
Tightened
Jam Nut**

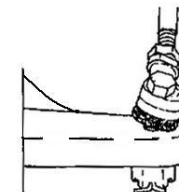

**Incorrectly
Tightened
Jam Nut**

BRAKES

- should be replaced. Always fill the reservoir as indicated whenever the cover is loosened or removed to insure proper diaphragm operation. Use DOT 3 brake fluid.
- Check brake system for fluid leaks.
- Check brake for excessive travel or spongy feel.
- Check friction pads for wear, damage and loosened.
- Check security and surface condition of the disc.
- Pads should be changed when friction material is worn to 3/64" (1mm). (A)

Checking the brake fluid level

Insufficient brake fluid may let air enter the brake system, possibly causing the brakes to become ineffective. Before riding, check that the brake fluid is above the minimum level mark and replenish if necessary. A low brake fluid level may

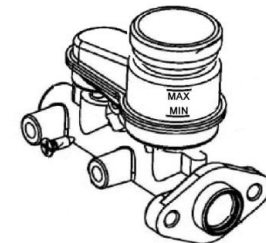

18. MAINTENANCE

indicate worn brake pads and/or brake system leakage. If the brake fluid level is low, be sure to check the brake pads for wear and the brake system for leakage.

- The brake fluid reservoir is located under the hood.
- When checking the fluid level, make sure the top of the brake fluid reservoir is level.
- Use only the recommended quality brake fluid. Otherwise, the rubber seals may deteriorate, causing leakage and poor braking performance.

Recommended brake fluid: DOT 3

- Refill with the same type of brake fluid. Mixing fluids may result in a harmful chemical reaction and lead to poor braking performance.
- Be careful that water does not enter the brake fluid reservoir when refilling. Water will significantly lower the boiling point of the fluid and may result in vapor lock.
- Brake fluid may deteriorate painted surfaces or plastic parts. Always clean up spilled fluid immediately.
- Have an authorized dealer inspect the brake system if the brake fluid level goes down.

Brake pedal and accelerator pedal lubrication

Lubricate the pivoting parts.

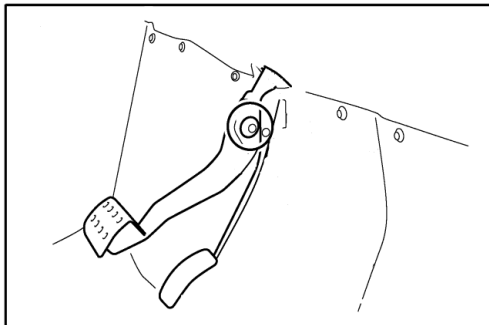

Recommended lubricant:
Lithium-soap-based
grease (all-purpose
grease)

PARKING BRAKE

Checking

Although the parking brake has been adjusted at the factory, the brake should be checked for proper operation. The mechanical brake must be maintained to be fully functional.

1. With the engine off, apply the parking brake lever and attempt to

18. MAINTENANCE

move the UTV.

2. If the rear wheels are locked, it is adjusted properly.
3. If the wheels are not locked, it must be adjusted.

Adjusting

To adjust (set up) the mechanical parking brake, use the following procedure

Note: The adjusting on the caliper is for the wear out of the pads.

1. With the engine off, loosen the adjuster on the lever.
2. Loosen the jam nut of the adjuster on the caliper.
3. Turn the adjuster (bolt) CW (clockwise) by hand till the pad touch the brake disc, turn the adjuster bolt CCW (counterclockwise) by 1/4 to one turn for 10 to 20mm free play at the end of the parking lever.
4. Tighten the jam nuts securely against the adjusters.
5. Make sure the rear wheels turns freely without dragging.
6. Turn the adjuster (the one on the lever) and apply the lever. While adjusting, it is important you apply the lever back and forth for operation, free play and the locking of the parking position.
7. Make sure the rear wheels turns freely without dragging and parking brake works properly.
8. Field test for parking. It must be capable of holding the laden UTV stationary on an 18% up and down gradient.

A temporary adjusting can also be done to the brake cable on the parking lever side by turn the adjuster (nut) directly. But the adjust range is limited. Always do the **procedure 1 to 8** when necessary.

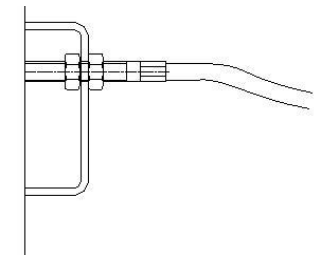

Throttle Free Play Inspection

1. Apply the parking brake.
2. Put gear in Neutral position.
3. Start the engine, and warm it up thoroughly.

18. MAINTENANCE

4. Measure the distance the throttle pedal moves before the engine begins to pick up seep. Free play should be 1/16" to 1/8" (1.5-3mm).

Throttle Free Play Adjustment

Throttle cable free play is adjusted at the cable, under the passenger seat.

1. Slide the boots off. Loosen adjuster locknut.
2. Turn adjuster until 1/16" to 1/8" (1.5 to 3mm) freeplay is achieved at the throttle pedal.

- NOTE:** While adjusting free play, it is important you flip the throttle pedal back and forth.
3. Tighten locknut and slide boots over cable adjuster.

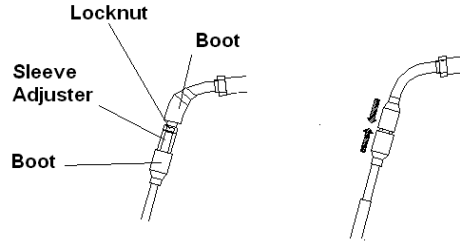

SPARK PLUGS

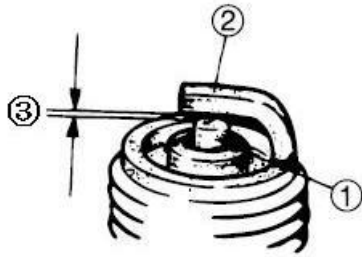

Standard spark plug: DR8EA

③ Gap: 0.8mm

- Inspect:
- Insulator ①
Abnormal color: Replace.
Normal color is a medium-To-light tan color.
 - Electrode ②
Wear/damage: Replace.
 - Clean spark plug
use spark plug cleaner or wire brush)
- Measure:
- Spark plug gap ③
Out of specification: Adjust gap.

Spark Plug Removal and Replacement



WARNING

Never attempt to remove a spark plug while the engine is warm. The exhaust system or engine could burn you causing severe injury.

18. MAINTENANCE

Remove the spark plug by rotating counterclockwise.
Reverse the procedure for spark plug installation.
Torque to 17ft.lbs (23N.m).

If you want to know more about maintenance details, please refer to the following table.

Due to the nature of the adjustments marked with a **D** on the following chart, it is recommended that service be performed by an authorized dealer.

- More often under severe use, such as dirty or wet conditions to purge water or dirt contamination from grease fittings and other critical components.

PERIODIC MAINTENANCE SCHEDULE

Careful periodic maintenance will help keep your vehicle in the safest, most reliable condition. Inspection, adjustment and lubrication intervals of important components are explained in the following chart on the following pages.

NOTE:

Maintenance intervals are based upon average riding conditions and an average vehicle speed of approximately 16 km/h. However, keep in mind that if the vehicle isn't used for a long period of time, the month maintenance intervals should be followed. Vehicles subjected to severe use, such as operation in wet or dusty areas, should be inspected and serviced more frequently.

Inspect, clean, lubricate, adjust or replace parts as necessary.

NOTE:

Inspection may reveal the need for replacement parts. Always use genuine parts available from your dealer.

Service and adjustments are critical. If you are not familiar with safe

18. MAINTENANCE

service and adjustment procedures, ask for a qualified dealer perform these operations.

| | Item | Hours | When | Remarks |
|---|---------------------------------|----------|----------|--|
| ● | Brake System | Pre-ride | Pre-ride | Pre-ride inspection item |
| | Accelerator pedal | Pre-ride | Pre-ride | Inspect –adjust, lubricate, replace if necessary; pre-ride inspection item |
| | Fuel System | Pre-ride | Pre-ride | Check for leaks at tank cap, lines, fuel valve, filter, and carburetor. |
| ● | Tires | Pre-ride | Pre-ride | Inspect daily, pre-ride inspection item |
| ● | Front and Rear Wheels/ Hubs | Pre-ride | Pre-ride | Pre-ride inspection item |
| ● | Steering | Pre-ride | Pre-ride | Inspect daily, lubricate |
| D | Wheels bearings | 10 hrs | Monthly | Check for looseness/ damage. Replace if damaged. |
| | Frame nuts, bolts fasteners | Pre-ride | Pre-ride | Pre-ride inspection item |
| ● | Air Filter-Pre-Cleaner | Daily | Daily | Inspect-Clean |
| | Coolant/Level Inspection | Daily | Daily | Replace engine coolant every one year |
| ● | Air Box Sediment Tube | Daily | Daily | Drain deposits whenever visible |
| | Headlamp Inspection | Daily | Daily | Check operation daily; apply dielectric grease to connector when replaced |
| | Tail/ indicator lamp inspection | Daily | Daily | Check operation daily; apply dielectric grease to socket when replaced |
| ● | Air Filter-Main Element | Weekly | Weekly | Inspect –Replace if necessary |
| ● | Transmission Oil Level | 20 hrs | Monthly | Inspect monthly; change annually |
| | Battery | 20 hrs | Monthly | Check/clean Terminals; check fluid level |
| D | Brake pad wear | 10 hrs | Monthly | Inspect periodically |
| ● | Front/Rear axle Gear case Oil | 100 hrs | Monthly | Check yearly or every 100 hours |
| | Engine Cylinder Head | 25 hrs | 3 months | Inspect (re-torque required at |

18. MAINTENANCE

| | | | | |
|---|-------------------------------------|-------------|-------------|--|
| | and Cylinder Base Fasteners | | | first service only) |
| ● | General Lubrication | 50 hrs | 3 months | Lubricate all fittings, pivots, cables, etc. |
| ● | Engine Oil-Level/Change | 30 hrs | 3 months | Check Level Daily; Break in Service at 1 month. Change oil more often in cold weather use. |
| ● | Dipstick | 50 hrs | 6 months | Inspect-clean |
| | Engine breather hose | 100 hrs | 6 months | Inspect |
| D | Throttle Cable/ Accelerator pedal | 20 hrs | monthly | Inspect –adjust, lubricate, replace if necessary; pre-ride inspection item |
| | Shift linkage | 50 hrs | 6 months | Inspect, adjust |
| D | Drive belt | 50 hrs | 6 months | Inspect, replace if necessary |
| D | Steering system | 50 hrs | 6 months | Check operation and for looseness, worn, damage, binding feeling / Adjust, repair, Replace if necessary. Check toe alignment /Adjust if necessary. |
| D | Toe alignment adjustment | As required | As required | Periodic inspection, adjust when parts are replaced |
| D | Shaft | 50 hrs | 6 months | Check for looseness/ damage. |
| ● | Axle | 50 hrs | 6 months | Inspect bearings, Lube |
| ● | Front Prop Shaft & Shaft Yoke | 50 hrs | 6 months | Check for looseness/ damage. |
| ● | Rear Prop Shaft, Shaft Yoke & Boots | 50 hrs | 6 months | Check for/ boots/ looseness/ damage. |
| ● | Front Suspension | 50 hrs | 6 months | Inspect-lubricate, tighten fasteners |
| ● | Rear Suspension | 50 hrs | 6 months | Inspect, tighten fasteners |
| | Spark Plug | 100 hrs | 12 months | Inspect-replace if necessary |
| D | Ignition Timing | 100 hrs | 12 months | Inspect and adjust as needed |
| D | Fuel System | 50 hrs | 6 months | Check for leaks at tank |

18. MAINTENANCE

| | | | | |
|---|-----------------------------|-------------|-------------|--|
| | | | | cap, lines, fuel valve, filter, and carburetor. Replace lines every one year |
| D | Fuel Filter | 100 hrs | 12 months | Replace annually |
| | Radiator | 100 hrs | 12 months | Inspect/clean external surface |
| | Spark arrestor | 50 hrs | 3 months | Clean out-replace if necessary |
| D | Clutches (drive and driven) | 25 hrs | 3 months | Inspect, clean |
| | Engine mounts | 25 hrs | 3 months | Inspect |
| D | Valve clearance | 100 hrs | 12 months | Inspect/adjust |
| D | Brake fluid | 200 hrs | 24 months | Change every two years |
| | Idle Speed | As required | As required | Adjust |
| | Headlight Aim | As required | As required | Adjust if necessary |

LUBRICATION RECOMMENDATIONS

| | Item | Lube Rec | Method | Frequency |
|---|----------------------------------|---------------|--|---|
| ● | 1. Engine Oil | SAE 15W/40SG | Add to proper level on dipstick | Check level daily |
| | 2.Brake Fluid | DOT 3 Only | Maintain level Between fill lines. See "7.CONTROL" | As require; change every two years or 200 hours |
| | 3.Transmission Oil | SAE 80W/90GL5 | Add to proper level on dipstick | Change annually or at 100 hours |
| | 4. Front/Rear axle Gear case Oil | SAE 80W/90GL5 | Front axle: 250ml Rear axle: 450ml | Change annually or at 100 hours |

18. MAINTENANCE

| | Item | Lube Rec | Method | Frequency |
|---|---|----------|---|----------------------------|
| ● | 5.Steering system | Grease | Lubricate the pivoting and sliding parts | Every 3 months or 50 hours |
| ● | 6.Shift Linkages | Grease | Locate fittings and Grease | Semi-annually |
| ● | 7.Front Wheel bearings | Inspect | Inspect and replace bearings if necessary | Semi-annually |
| ● | 8.Ball joints | Grease | Inspect, Locate fittings and Grease, or replace it if necessary | Semi-annually |
| ● | 9.Prop Shaft & Shaft Yoke, Spline Joint | Grease | Locate fitting and Grease | Semi-annually |
| ● | 10.Rear Axle Bearing | Grease | Grease | Every 3 months or 50 hours |
| ● | 11.Swing Arm Bearing | Grease | Grease | Monthly or 20 hours |
| ● | 12.Throttle Cable | Grease M | Grease, inspect and replace it if necessary | Monthly or 20 hours |
| ● | 13. Accelerator pedal and brake pedal | Grease | Grease, inspect | Monthly or 20 hours |

NOTE:

1. More often under severe use, such as wet or dusty conditions .
2. Grease: Light weight lithium-soap grease.
3. Grease M: molybdenum disulfide(MoS₂) grease(water resistant).
4. *When suspension action becomes stiff or after washing.
5. Hours are based on 10 mph(16Km/h) average.