

# **Agri-Fab®**

**Lawn Care Made Easy®**

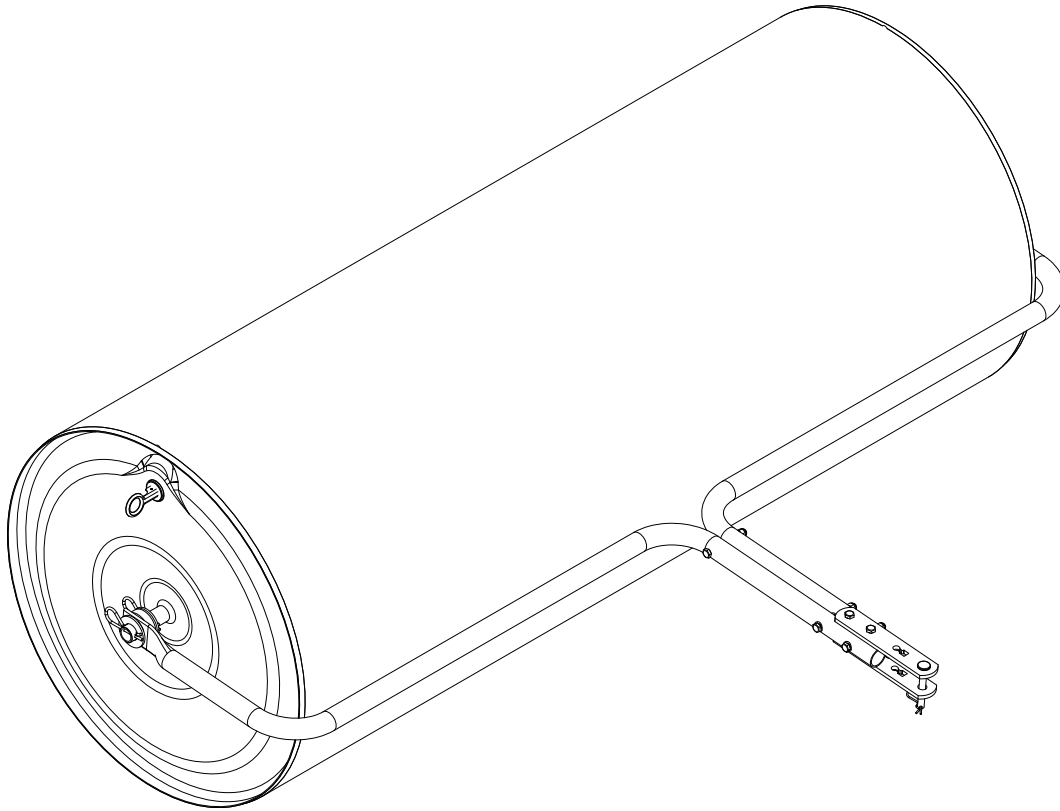

**45-0549**

## **SPECIFICATIONS**

**Roller Drum:** 24" Dia. x 60" Wide, Welded Steel

**Tow Hitch:** Std. Pin Type - 1/2" Hole

**Unit Weight:**

*Empty: Approximately 135 Lbs.*

*Filled: Up to 1150 lbs. filled with water*

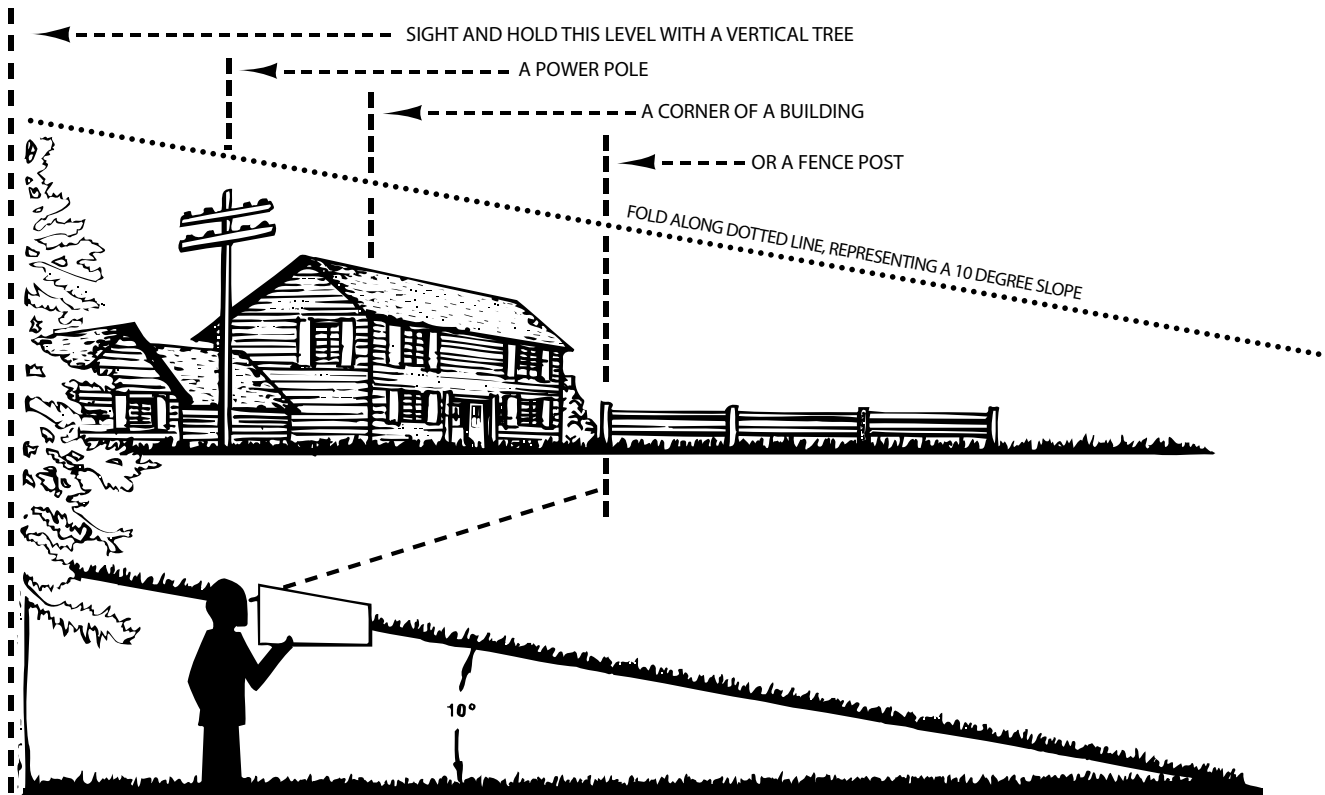

## SAFETY

1. Read and follow all instructions in this manual before attempting to assemble or operate this equipment. Failure to comply with these instructions may result in personal injury. Keep this manual in a safe place for future reference and for ordering replacement parts.
2. Read the vehicle owner's manual and vehicle safe operation rules before using this equipment.
3. Do not allow anyone to operate this equipment without proper instructions.
4. Keep the area of operation clear of all persons and animals.
5. Check all bolts and fasteners for tightness before each use to insure safe operation.
6. Always wear safety glasses and other personal protective equipment referenced in your vehicle's owners manual when operating and maintaining this equipment.
7. Do not operate this equipment while in an impaired state.
8. When using this equipment, start with the vehicle at a low speed increasing speed only as conditions permit. **Do not exceed 3mph (5km/h).**
9. Operate this equipment at reduced speed on rough terrain, along creeks and ditches and on slopes to prevent loss of control. Refer to the slope guide above for safe operating procedures.
10. Vehicle braking and stability are affected by the addition of this equipment. Do not exceed the vehicle's towing capacity referenced in your vehicle's owner's manual.
11. Do not attempt to manually push or pull roller while it is full. Attempting to do so could result in personal injury.
12. Drain roller before freezing temperatures to avoid damage.

# ASSEMBLY INSTRUCTIONS

(SEE ILLUSTRATION BELOW)

1. Assemble bearing (Ref. 7) into hitch tube (Ref. 2) so that bearing flange is against outside of hitch tube. *You may need to place a block of wood against bearing and carefully tap with a hammer.*
2. Place Cotter Pin (Ref. 12) into the inside hole of the axle.
3. Slide the washer (Ref. 6), spacer (Ref. 3), hitchtube (Ref. 2), washer (Ref. 6) onto the axle.
4. Place Cotter Pin (Ref. 12) into the outside hole of the axle.
5. Repeat steps 1 through 4 on the other side.
6. Bring the two hitch tubes together using hex bolts (Ref. 8) and hex lock nuts (Ref. 10). **Do not tighten yet.**
7. Assemble hitch brackets (Ref. 1) to hitch tubes (Ref. 2) using two hex bolts (Ref. 4) and hex lock nuts (Ref. 10).
8. **Tighten** bolts and nuts starting with hitch tubes(Ref. 2), ending with hitch brackets (Ref. 1).
9. Install hitch pin (Ref. 9) through hitch brackets (Ref. 1) and secure with hair cotter pin (Ref. 5).
10. Adjust plug (Ref. 11) size by twisting handle. Lock a plug in each end of roller drum by **flipping handle down.**

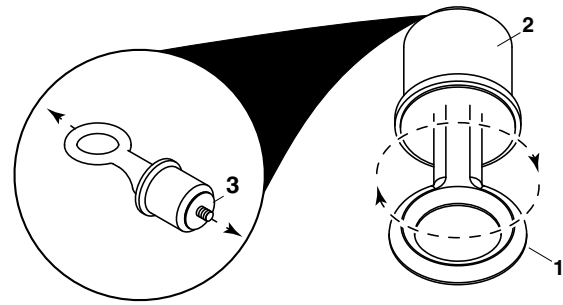

## Plug Instructions

### Instructions for tightening plug:

- Grip ring (1) with right hand and plug (2) end with left hand
- Pull plug and ring in opposing directions
- Twist ring (1) clockwise to tighten and counter-clockwise to loosen

**NOTE:** If the outer washer (3) is stuck, use a pair of needlenose pliers to ensure that it is free.

### Instructions for emptying roller:

- Remove both plugs for more efficient draining

**CAUTION**

ROLLER WILL CHANGE HANDLING AND BRAKING OF VEHICLE, ESPECIALLY ON SLOPES. FOLLOW TOWING GUIDELINES IN ROLLER AND TOWING VEHICLES OWNER'S MANUALS.  
DO NOT EXCEED SLOPES GREATER THAN 10°

**MAX WEIGHT WITH WATER**

45-0179 — 640 lbs.    45-0268 — 375 lbs.  
45-0216 — 910 lbs.    45-0269 — 550 lbs.  
45-0267 — 250 lbs.    45-0549 — 1150 lbs.

45906

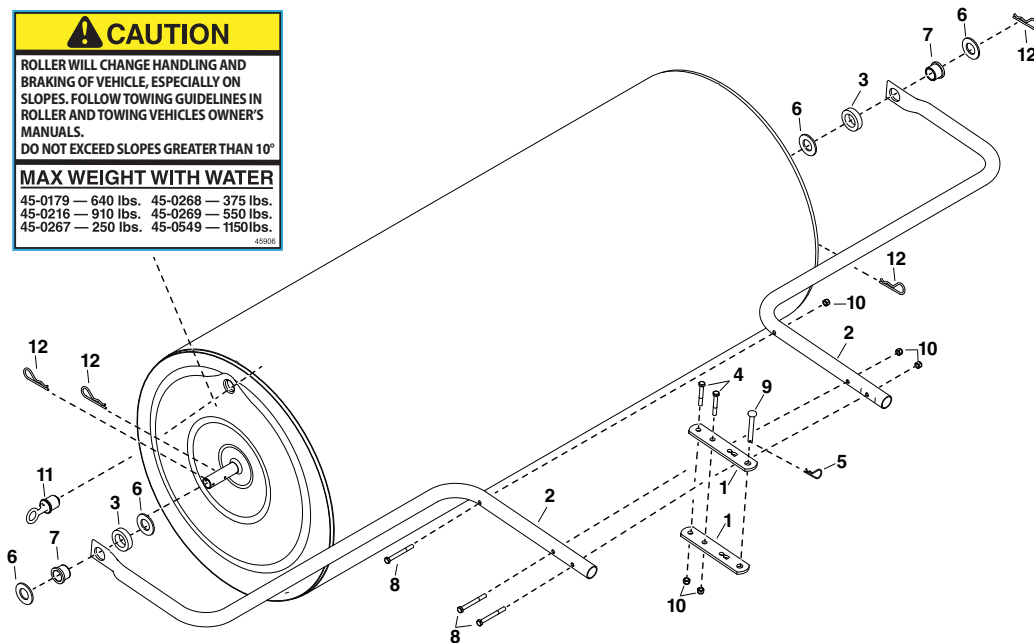

REF	PART NO.	QTY	DESCRIPTION	REF	PART NO.	QTY	DESCRIPTION
1	24192BL1	2	Bracket, Hitch (Straight)	10	47810	5	Nut, Hex .312-18 x
2	28651BL3	2	Tube, Hitch (Roller)	11	49467	2	Plug, Roller (1-1/4)
3	40740	2	Spacer, 1.28 ID x 2.0	12	714-0117	4	Pin, Hair Cotter 5/3
4	43224	2	Bolt, Hex 5/16-18 x			1	Assembly, 24x60 Roller
5	43343	1	Pin, Hair Cotter		45849	1	Owner's Manual
6	43528	4	Washer, 1" SAE 1.06		45906	1	Roller Caution Label
7	43632	2	Bearing Plastic				
8	46782	3	Bolt, Hex 5/16-18 x				
9	47623	1	Pin, Hitch 3/8 x 3 F				

***SpeedPart*** *the fastest way to purchase parts* [www.speedepart.com](http://www.speedepart.com)

**REPAIR PARTS**

Agri-Fab, Inc.  
809 South Hamilton  
Sullivan, IL. 61951  
1-800-448-9282  
[www.agri-fab.com](http://www.agri-fab.com)