



## **38 INCH SWEEPER QUICK ASSEMBLE**

with Quick Height Adjustment Handle

### **OWNER'S MANUAL**



#### **WARNING:**

Read carefully and understand all **ASSEMBLY AND OPERATION INSTRUCTIONS** before operating. Failure to follow the safety rules and other basic safety precautions may result in serious personal injury.

**Model# YTF-38STQA**

Thank you very much for choosing this product! For future reference, please complete the owner's record below:

Model: YTF-38STQA Purchase Date: \_\_\_\_\_

Save the receipt, warranty and these instructions. It is important that you read the entire manual to become familiar with this product before you begin using it.

This machine is designed for certain applications only. The manufacturer cannot be responsible for issues arising from modification. We strongly recommend this machine not be modified and/or used for any application other than that for which it was designed. If you have any questions relative to a particular application, DO NOT use the machine until you have first contacted us to determine if it can or should be performed on the product.

For technical questions please call **1-218-943-6296**.

## TECHNICAL SPECIFICATIONS

Item	Description
Working Width	38 inches Wide
Hitch Style	Universal Pin Style Hitch
Construction finish	Steel construction with powder coat paint finish
Bag Dimensions	41"W x 29"L x 22"H (12.5 cu. ft. capacity)

## GENERAL SAFETY RULES



**WARNING:** Read and understand all instructions. Failure to follow all instructions listed below may result in serious injury.



**CAUTION:** Do not allow persons to operate or assemble this sweeper until they have read this manual and have developed a thorough understanding of how the sweeper works.



**WARNING:** The warnings, cautions, and instructions discussed in this instruction manual cannot cover all possible conditions or situations that could occur. It must be understood by the operator that common sense and caution are factors which cannot be built into this product, but must be supplied by the operator.

## SAVE THESE INSTRUCTIONS

## WORK AREA – DURING ASSEMBLY and OPERATION

- **Keep work area clean**, free of clutter and well lit. Cluttered and dark work areas can cause accidents.
- **Keep children and bystanders** away while assembling or operating the sweeper. Distractions can cause you to lose control, so visitors should remain at a safe distance from the work area.
- **Be aware of all power lines, electrical circuits**, water pipes and other mechanical hazards in your work area, particularly those hazards below the work surface hidden from the operator's view that may be unintentionally contacted and may cause personal harm or property damage.
- **Be alert of your surroundings**. Using the sweeper in confined work areas may put you dangerously close to cutting tools and rotating parts.

## PERSONAL SAFETY

- **Stay alert**, watch what you are doing and use common sense when using the sweeper. Do not use the sweeper while you are tired or under the influence of drugs, alcohol or medication. A moment of inattention while operating the sweeper may result in serious personal injury.
- **Dress properly**. Do not wear loose clothing, dangling objects, or jewelry. Keep your hair, clothing and gloves away from moving parts. Loose clothes, jewelry or long hair can be caught in moving parts.
- **Use safety apparel and equipment**. Use safety goggles or safety glasses with side shields which comply with current national standards, or when needed, a face shield. Use as dust mask in dusty work conditions. This applies to all persons in the work area. Also use non-skid safety shoes, hardhat, gloves, dust collection systems, and hearing protection when appropriate.

## SWEEPER USE AND CARE

- **Do not modify the sweeper in any way**. Unauthorized modification may impair the function and/or safety and could affect the life of the equipment. There are specific applications for which the sweeper was designed.
- **Always check for damaged or worn out parts before using the sweeper**. Broken parts will affect the sweeper operation. Replace or repair damaged or worn parts immediately.
- **Distribute the load evenly**. Uneven loads may cause the sweeper to tip, resulting in personal injury to the operator or others.
- **Use the sweeper on flat and level surfaces** capable of supporting the sweeper and its maximum load. Pulling or pushing a load on a slanted or uneven surface can result in loss of control.
- **Store idle sweeper**. When the sweeper is not in use, store it in a secure place out of the reach of children. Inspect it for good working condition prior to storage and before re-use.

## **ASSEMBLY INSTRUCTIONS:**

### **PRE-ASSEMBLY NOTES:**

HELPFUL TIP: Fully read instructions before beginning assembly.

### **TOOLS RECOMMENDED:**

Qty 2: 10mm Combination Wrenches

Qty 2: 11mm Combination Wrenches

Qty 2: 12mm Combination Wrenches

Qty 2: 13mm Combination Wrenches

Qty 1: 5mm Allen Wrench

NOTE: Reference numbers in the instructions are from the Main Sweeper Parts Page 5 and Hardware Parts Listing Page 6.

1. Remove all hardware and parts from carton(s).
2. Verify all parts and hardware are included.
3. If parts are missing DO NOT return to place of purchase, contact customer service FIRST for replacement parts to be sent directly to you.

# Main Sweeper Parts

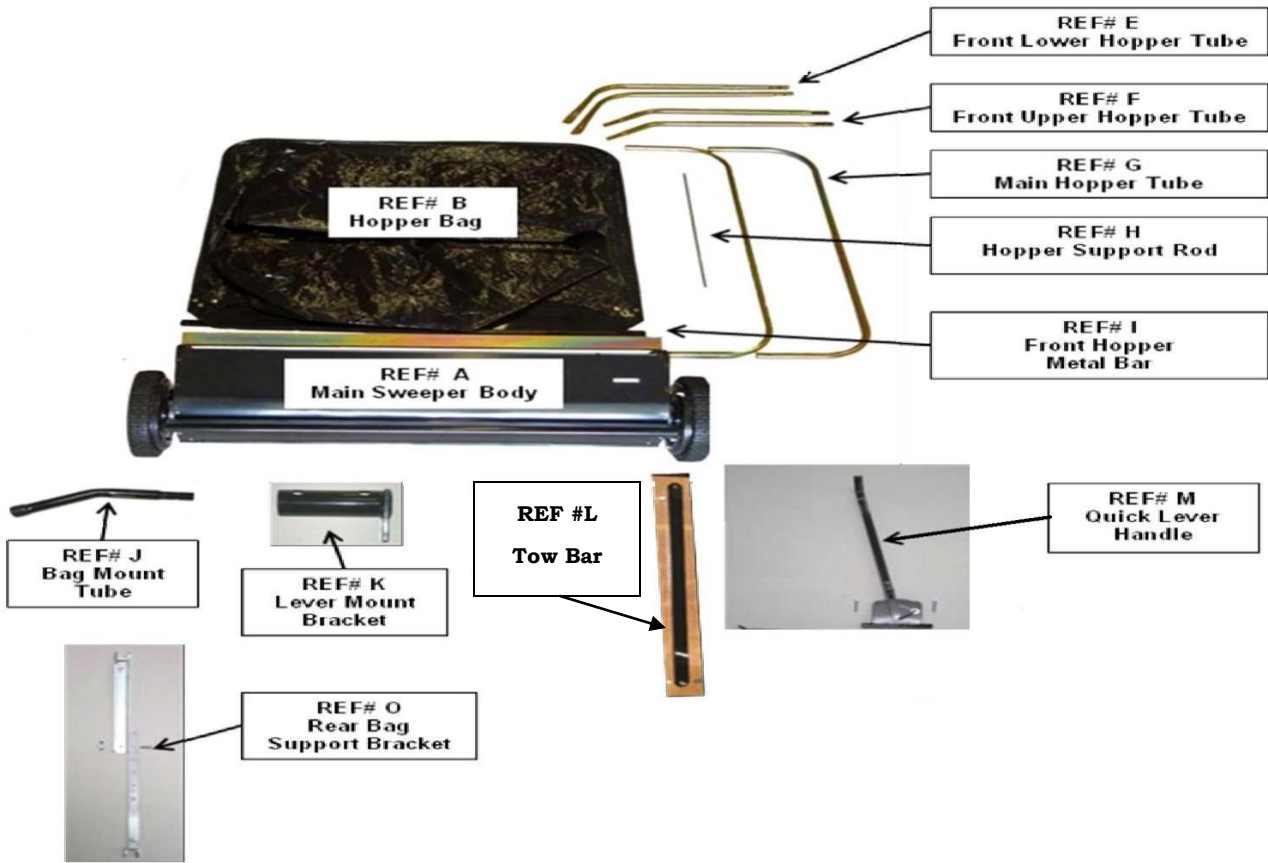

REF#	Part Listing #	Description	Qty
A		Main Sweeper Body	1
B	67	Hopper Bag	1
E	76	Front Lower Hopper Tube - Right	1
E	62	Front Lower Hopper Tube - Left	1
F	72	Front Upper Hopper Tube - Right	1
F	63	Front Upper Hopper Tube - Left	1
G	66	Main Hopper Tube	2
H	70	Hopper Support Rod	1

REF#	Part Listing #	Description	Qty
I	74	Front Hopper Metal Bar	1
J	71	Bag Mount Tube	2
K	A2	Lever Mount Bracket	1
L	A6	Tow Bar	1
M	A9	Quick Lever Handle	1
O	B4/B5	Rear Bag Support Bracket	1
	68	Rope (not pictured)	1

## Hardware Parts Listing

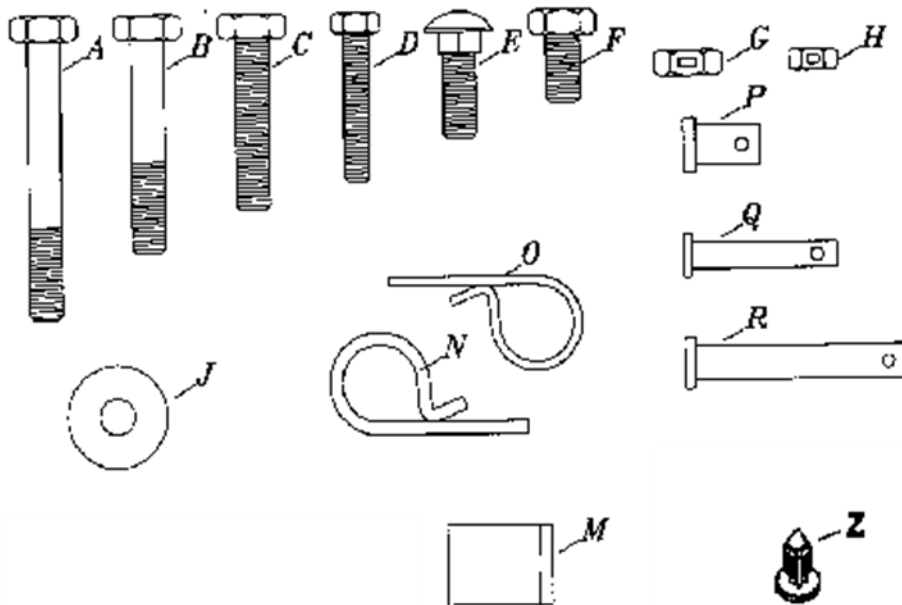

**NOT SHOWN FULL SIZE**

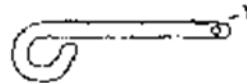

## HARDWARE PARTS LISTING

REF#	Part #	Description	Qty
A	9	Hex Bolt, 3/8" X 3"	2
B	7	Hex Bolt, 5/16" X 2"	2
C	20	Hex Bolt, 5/16" X 1-1/2"	2
D	38	Hex Bolt, 1/4" X 1-1/2"	8
E	B-2	Carriage Bolt, 1/4" X 1-1/2"	2
F	18	Hex Bolt, 5/16" X 5/8"	4
G	1	Hex Lock Nut, 5/16"	8
H	11	Hex Lock Nut, 1/4"	35
J	A15	Flat Washer, 1/4"	4

REF#	Part #	Description	Qty
M	5	Hitch Spacer Tube	2
N	3	Hair Cotter Pin (Ø3 Thickness)	5
O	22	Hair Cotter Pin (Ø2 Thickness)	4
P	75	Clevis Pin P, Ø9.5 × 7/8" long	2
Q	61	Clevis Pin Q, Ø6 × 1-1/8" long	4
R	17	Clevis Pin R, Ø9.5 × 2-3/8" long	2
Y	10	Hitch Pin	1
	B6	Wing Nut (not shown)	1
Z	A7	Flat hex head bolt 1/4" x 3/4"	1

## STEP #1 MOVE TOW BAR INTO POSITION

Parts Needed:

Qty 2 – 3/8" x 2" Bolt (Part# Q4)

Qty 2 – 3/8" Lock Nut (Part# Q5)

Qty 1 – 3/8" Flat Washer (Part# Q6)

**Wait to tighten connections.**

Figure 1



## STEP #2 CONNECT QUICK LEVER HANDLE TO TOWBAR

Parts Needed

Qty 1 – Quick Level Handle (Part #A9)

Qty 2 – 5/16" x 2" Bolt (Part #7)

Qty 2 – 5/16" Hex Lock Nut (Part #1)

## CONNECT HANDLE CONNECTOR BAR TO TOWBAR AND LEVEL BRACKET

Qty 1 – Tow Bar (Part #A6)

Qty 1 – 1/4" x 3/4" Slotted Pan Head Screw (Part #A7)

Qty 1 – 1/4" x 3/4" Hex Bolt (Part #59)

Qty 2 – 1/4" Hex Lock Nut (Par #11)

Align the holes in Quick Lever Handle to the Tow Bar and to the Main Sweeper Body.

Make sure Tow Bar is in position as shown in Figure 2.

Hand tighten all connections. Be sure to test handle to assure all parts move freely.

**Tighten connections.**

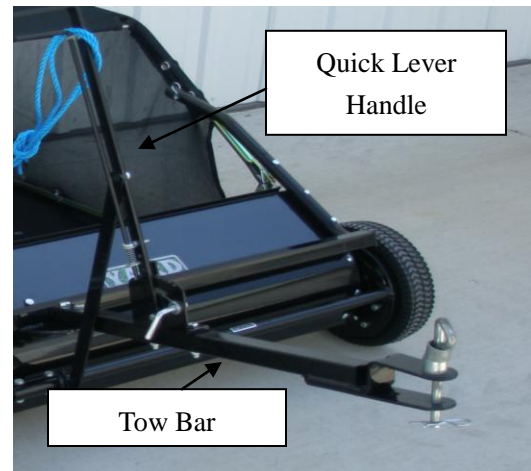

Figure 2

## ASSEMBLING THE SWEEPER BAG

### STEP #3 INSERT MAIN HOPPER TUBE – TOP SIDE

Parts Needed:

Qty 1 – Hopper Bag (Part #67)

Qty 1 – Main Hopper Tube (Part #66)

Insert one Main Hopper Tube through loops in top of Hopper Bag. See Figure 3

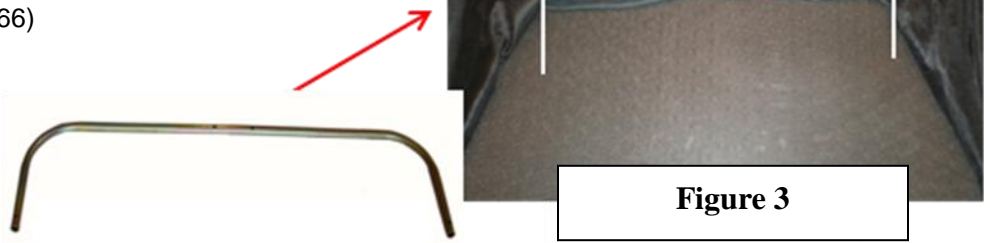

Figure 3

### STEP #4 ATTACH UPPER HOPPER TUBES to MAIN HOPPER TUBE – TOP SIDE

Parts Needed:

Qty 2 – UPPER Hopper Tubes (Part #63 & 72)

Qty 2 – 1/4" x 1-1/2" Hex Bolt (Part #38)

Qty 2 – 1/4" Hex Lock Nut (Part #11)

Connect UPPER Hopper Tube to Main Hopper Tube using 1/4" x 1-1/2" Hex Bolts (Part #38) and 1/4" Hex Lock Nut (Part #11).

**Do not over tighten.**

See Figure 4

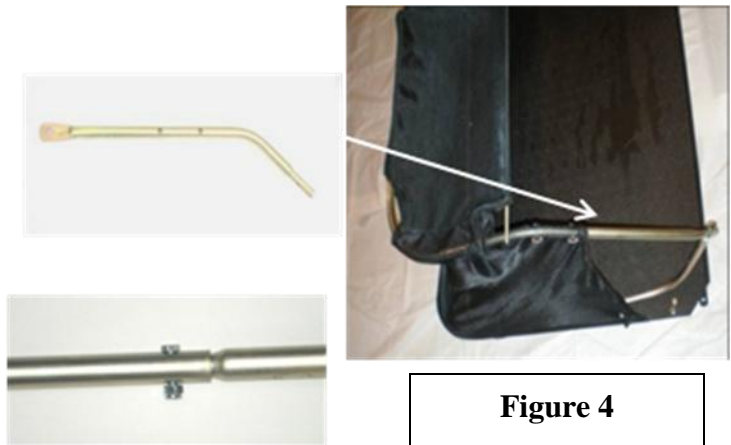

Figure 4

Connect tubes like this

### STEP #5 ATTACH LOWER HOPPER TUBES to MAIN HOPPER TUBE – BOTTOM SIDE

Parts Needed:

Qty 2 – LOWER Hopper Tubes (Part #62 & 76)

Qty 2 – 1/4" Flat Washers (Part #A15)

Qty 2 – 1/4" x 1-1/2" Hex Bolt (Part #38)

Qty 2 – 1/4" Hex Lock Nut (Part #11)

Connect the 2 LOWER Hopper Tubes to Main Hopper Tube. **IMPORTANT: Wait to use nut and bolt.** Slide LOWER Hopper Tubes into bottom of hopper bag. Attach using 1/4" Flat Washers (Part #A15) and 1/4" x 1-1/2" Hex Bolt (Part #38). Insert the bolt from bottom of Hopper Bag through the assembled tubes.

Tighten with Hex Lock Nuts (Part #11). See Figure 5

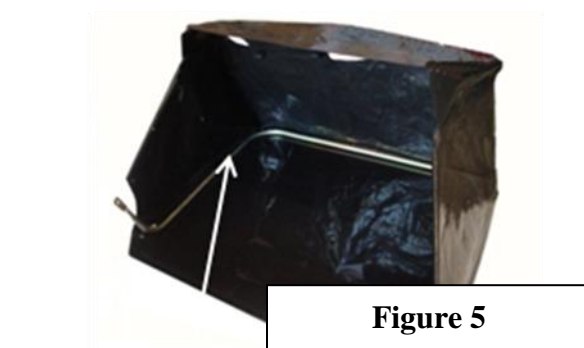

Figure 5

Insert bolt & washer from bottom, then secure with nut from inside bag.



Figure 6

### STEP #6 ATTACH REAR SUPPORT BRACKET

Parts Needed:

- Qty 1 – Rear Bag Support Bracket (Part #B4 & B5)
- Qty 2 – 1/4" x 1-1/2" Carriage Bolt (Part #B2)
- Qty 2 – 1/4" x 5/8" Carriage Bolt (Part #19-2)
- Qty 2 – 1/4" Hex Lock Nut (Part #11)
- Qty 1 – 1/4" x 5/8" Bolt (Part #B7)
- Qty 1 – Wing Nut (Part #B6)

Assemble the Rear Bag Support Brackets using 1/4" x 5/8" Carriage Bolts (Part #B2), 1/4" x 5/8" Bolt (Part #B7) and Wing Nut (Part #B6).

Connect Rear Bag Support Bracket Assembly to top and bottom Main Hopper Tubes using 1/4" x 1-1/2" Carriage Bolt (Part #B2) and 1/4" Hex Lock Nut (Part #11).

See Figure 6

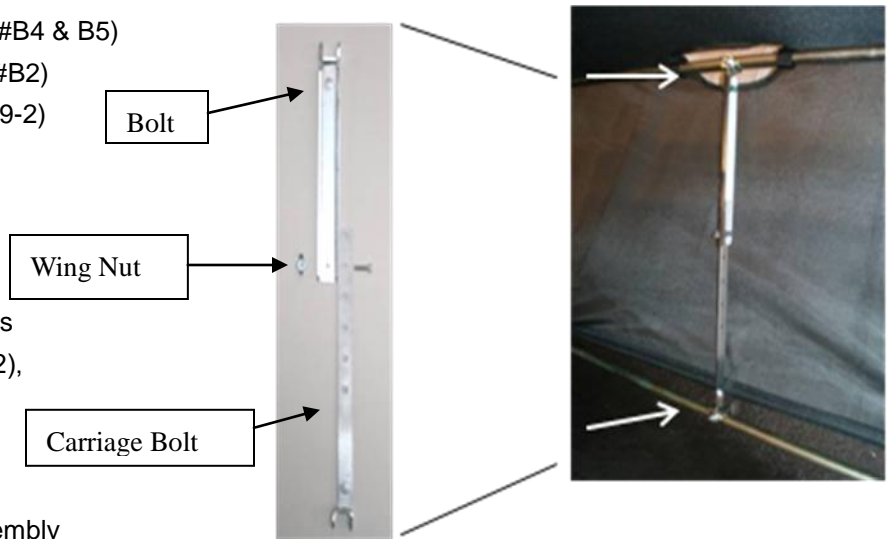

View of inside of hopper back side. Connect rear bag support to top and bottom

### STEP #7 CONNECT UPPER & LOWER TUBES

Parts Needed:

- Qty 2: Clevis Pin P (Part #75)
- Qty 2: Hair Cotter Pin (Part #3)

Connect the ends of the Lower Hopper Tubes to the ends of the Upper Hopper Tubes using two Clevis Pins P (Part #75) inserted from the inside, and two Hair Cotter Pins (Part #3).

### STEP #8 INSTALL HOPPER BAG SUPPORT ROD

Parts Needed:

- Qty 1 – Hopper Bag Support Rod (Part #70)

Insert Hopper Bag Support Rod through top Front of bag. Insert each end of Hopper Bag Support Rod into the Hopper Tubes. Holes are pre-drilled in Hopper Tubes. The Hopper Bag Support Rod will have a slight bend to hold tight between Hopper Tubes.

See Figure 7

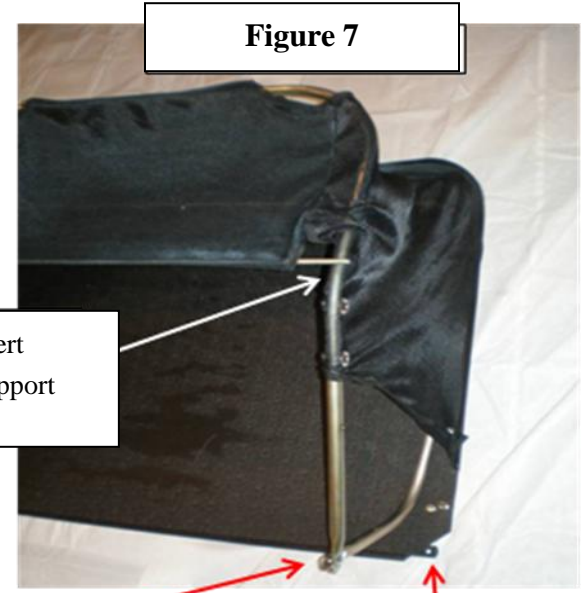

Figure 7

Step 8: Insert Hopper Support Rod Here

Step 7: Connect with Clevis Pin and Cotter Pin

Step 9: Insert Front Hopper Securing Bar here

## STEP #9 INSERT FRONT HOPPER SECURING BAR

Parts Needed:

Qty 1 – Front Hopper Metal Bar (Part #74)

Qty 2 – Clevis Pin (Part #61)

Qty 2 – Hair Cotter Pin (Part #22)

Insert the Front Hopper Metal Bar into the stitched sleeve on the front edge of the Hopper Bag bottom. Connect the Front Hopper Securing Bar to the Lower Hopper Tubes with two Clevis Pins (Part #61) and two Hair Cotter Pins (Part #22). See Figure 7

## STEP #10 ATTACH BAG MOUNT TUBES

Parts Needed:

Qty 2 – Bag Mount Tubes (Part #71)

Qty 2 – Clevis Pin R (Part #17)

Qty 2 – Hair Cotter Pin (Part #3)

**IMPORTANT** – Note direction of tubes. The bend/angle points down. Connect Bag Mount Tubes to Upper Hopper Tubes using a Clevis Pin R (Par #17) and a Hair Cotter Pin (Part #3). Insert the Clevis Pin from outside of bag. The Hair Cotter Pin should be on the inside of bag. See Figure 10

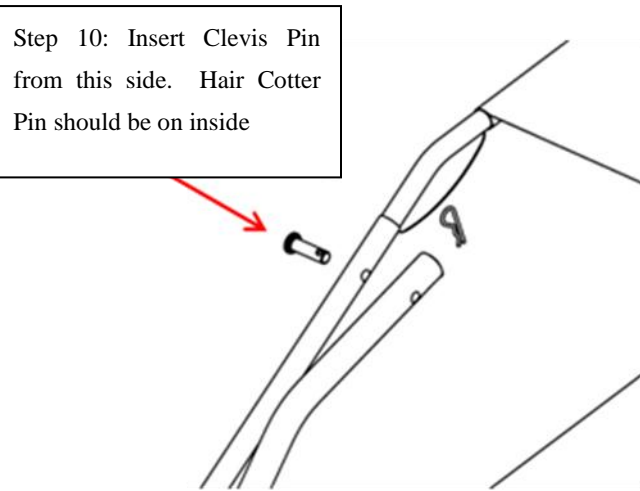

Figure 10

## STEP #11 ATTACH BAG TO SWEEPER

Parts Needed:

Qty 2 – Clevis Pin Q (Part #61)

Qty 2 – Hair Cotter Pin (Part #22)

Align the ends of the Bag Mount Tubes with the ends of the Sweeper Hitch Tubes and fasten with Clevis Pin R (Part #61) and Hair Cotter Pin (Part #22) for each side. See Figure 11

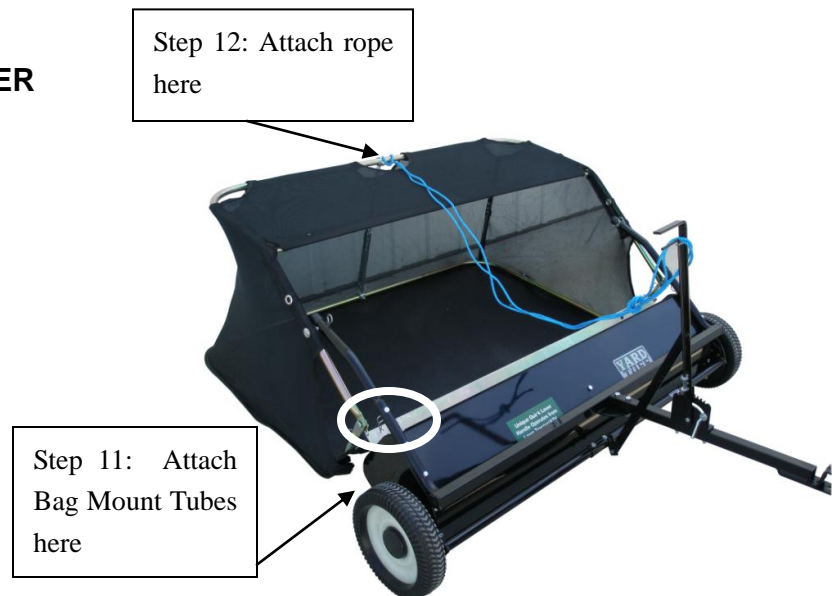

Figure 11

## STEP #12 ATTACH ROPE

Tie the rope to the open area at the top center of the Hopper Bag Frame. See Figure 11

## OPERATION



**WARNING: AVOID OPERATING ON SIDE HILLS.** Operating on side hills may cause unit to tip over and cause damage to sweeper and towing vehicle.

For best sweeping results, do not tow over 3 to 5 MPH. Use Quick Lever handle to adjust brushes up and down. For best results operate with brushes slightly above ground.

Hook up to towing lawn tractor or ATV. Use hitch spacers to help keep sweeper hitch level to ground see figure 20 and 21 below. ALWAYS try to keep sweeper level.

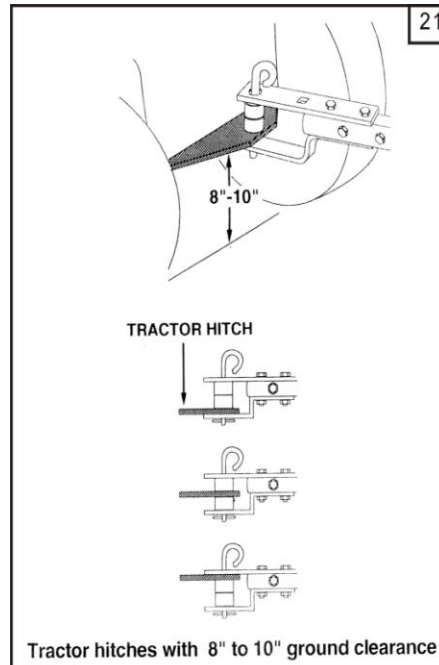
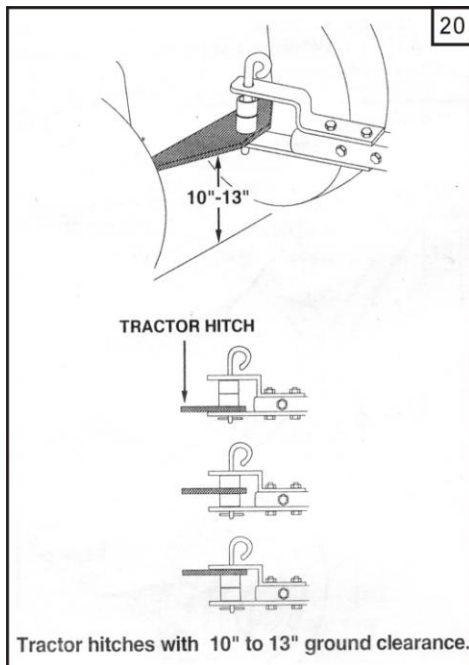

## BRUSH HEIGHT ADJUSTMENT

To adjust your sweeper brushes to the best operating height, loosen the adjustment knob and push down on the height adjustment lever to raise the brush. Best adjustment is when the brush setting is 1/2" down into the grass. Always mow the grass to an even height before sweeping.

## SWEEPING SPEED

Try a starting speed of approximately 3 m.p.h. (third gear on most tractors). Depending on the conditions, it may be necessary to adjust the sweeping speed in order to achieve best results.

## DUMPING OF SWEEPER

Your sweeper can be dumped easily without getting off of the rider or tractor. Simply pull the rope forward to dump the hopper. Always empty hopper after each use.



**CAUTION: Never attach** the hopper rope to any part of your body or clothing! **Never hold onto** the rope while towing the sweeper! **Attach the rope** to the towing vehicle to keep it away from wheels and rotating parts.



**CAUTION:** Keep sweeper away from fire. Excessive heat can damage the brushes and hopper bag and could cause the bag and its contents to burn.

# Parts Diagram

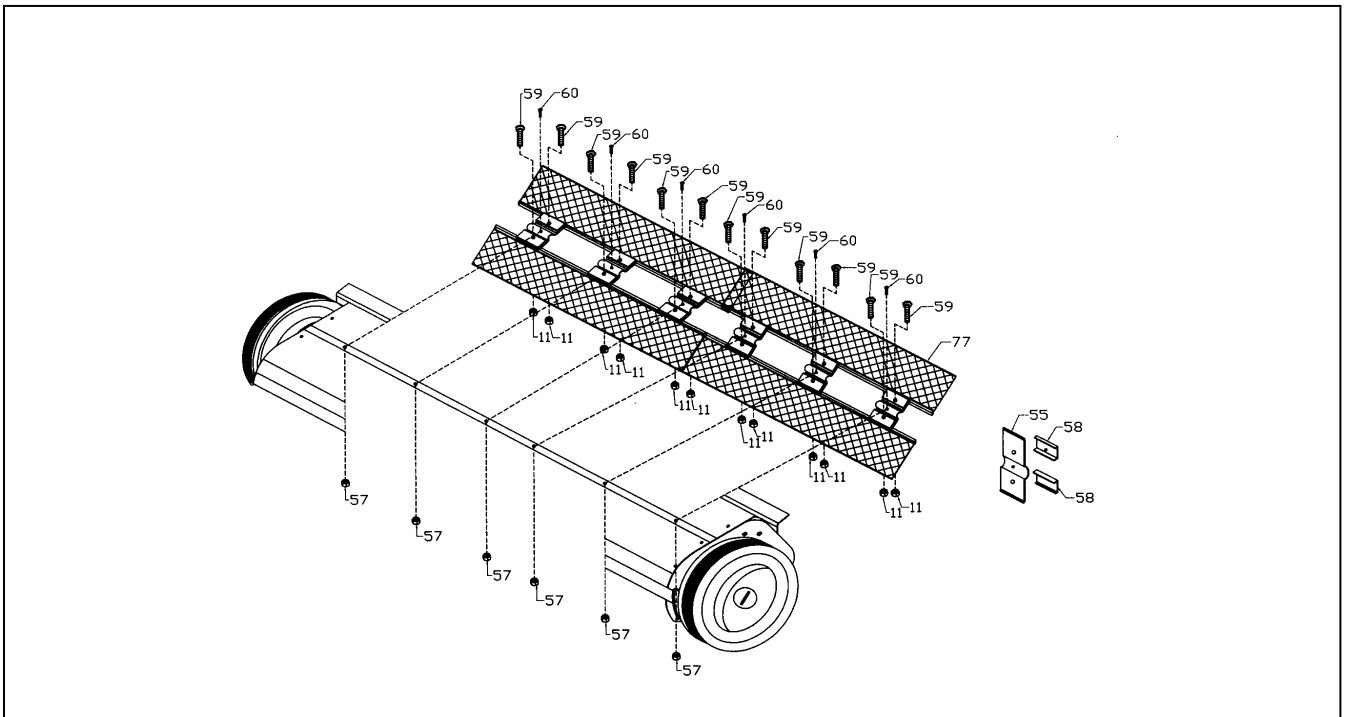
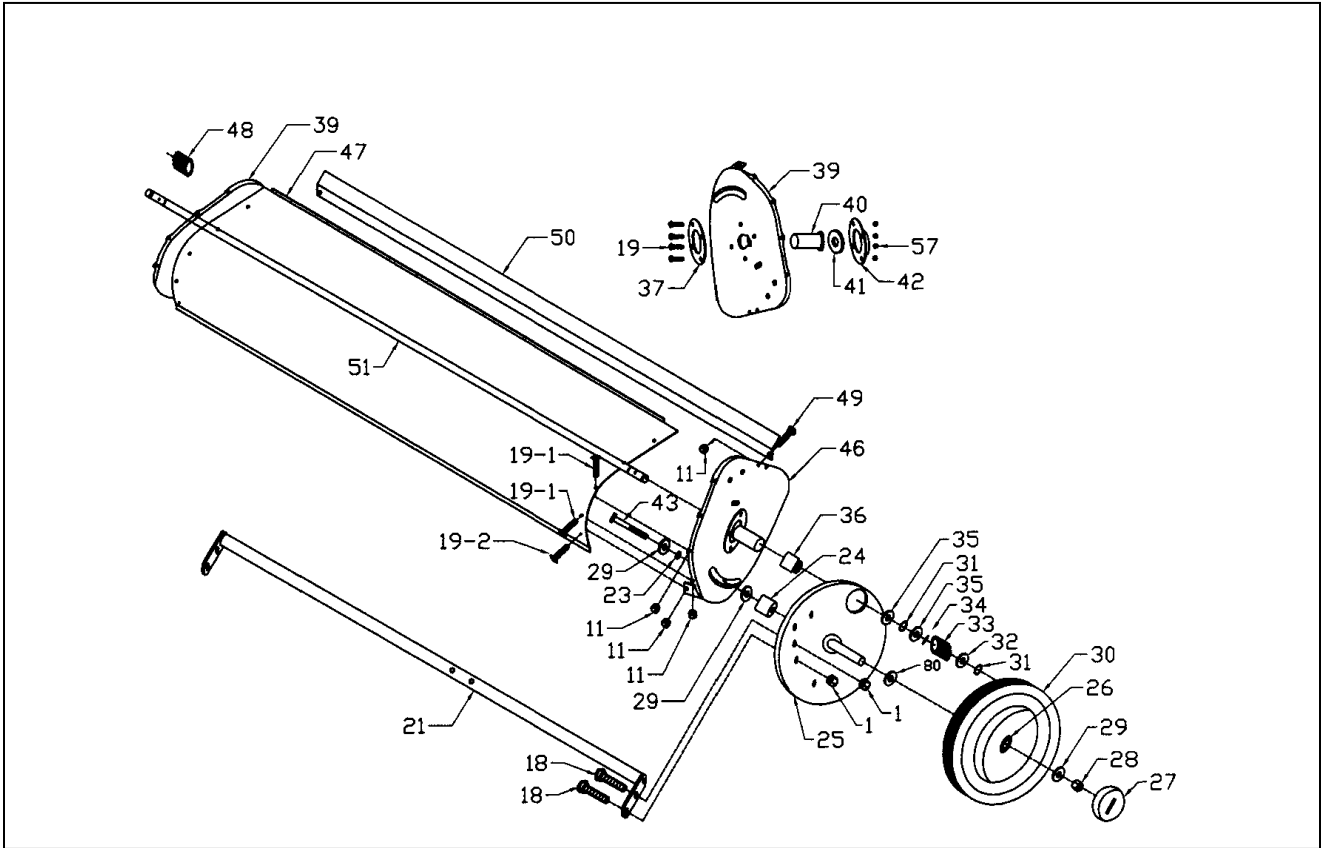

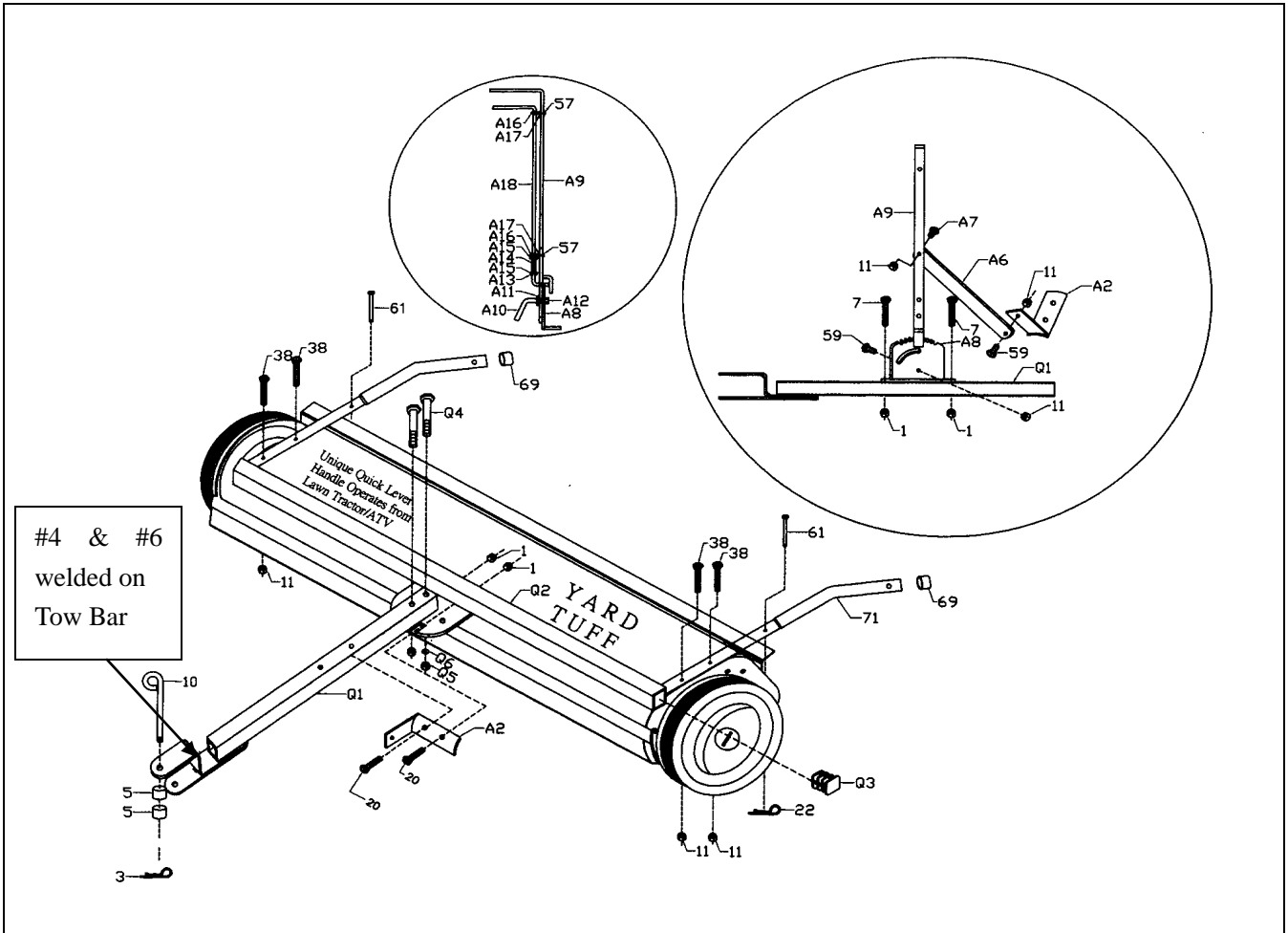
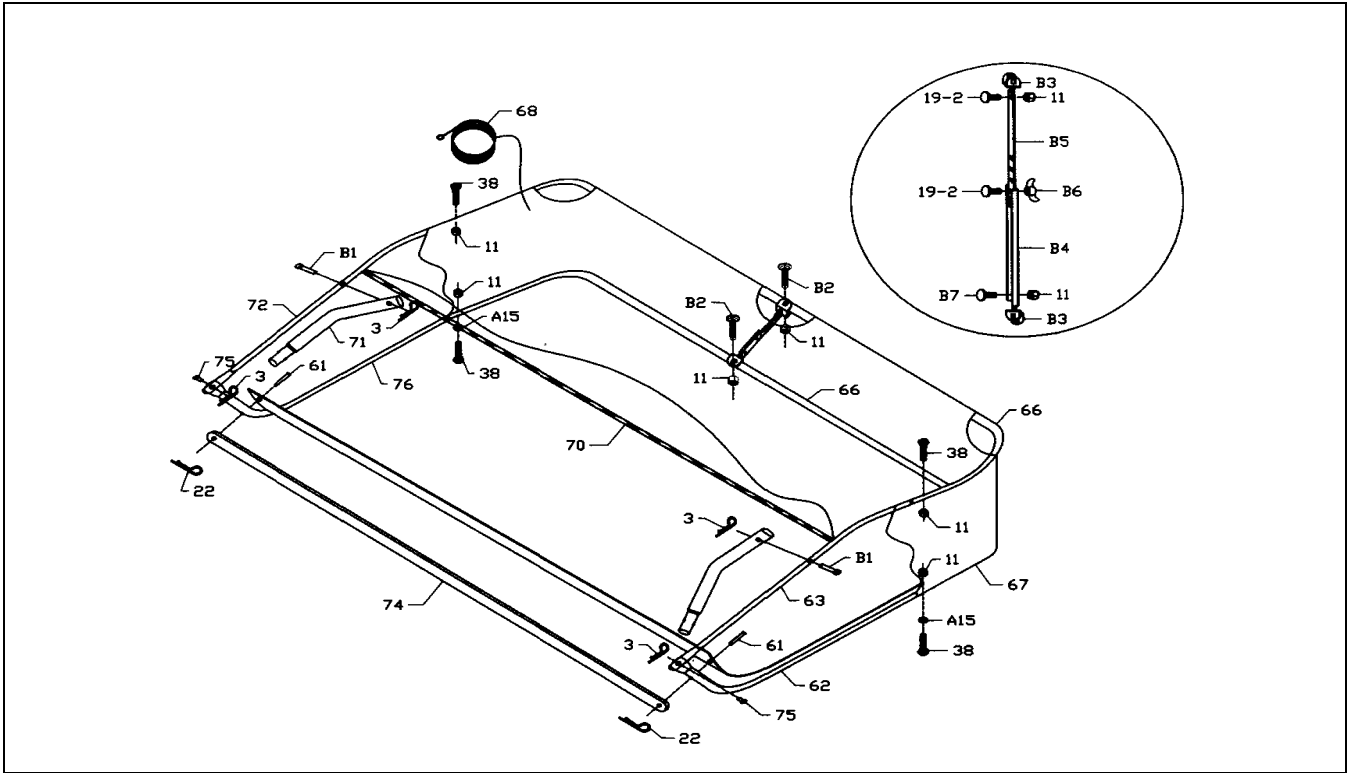

## Parts List 48" Sweeper - Quick Assemble

Part No.	Description	Qty.	Part No.	Description	Qty.
1	Hex Lock Nut, 5/16"	8	58	Retainer, Brush(single)	12
3	Hair Cotter Pin, Ø3	5	59	Hex Bolt, 1/4" x 3/4"	14
4	Hitch Bracket (Straight)	1	60	Hex Bolt, 3/16" x 1"	6
5	Hitch Spacer Tube	2	61	Clevis Pin Q, Ø6x37	4
6	Hitch Bracket	1	62	Lower Hopper Frame Tube(L.H)	1
7	Hex Bolt, 5/16" x 2"	2	63	Upper Hopper Frame Tube(L.H)	1
10	Hitch Pin Ø10	1	66	Main Hopper Tube (Rear)	2
11	Hex Lock Nut, 1/4"	35	67	Hopper Bag	1
17	Clevis Pin R, Ø9.5 x 2-3/8" long	2	68	Hopper Rope	1
18	Hex Bolt, 5/16" x 5/8"	4	69	Vinyl Cap	2
19	3/16" x 1/2" Screw	8	70	Bag Support Rod	1
19-1	1/4" x 1/2" Pan Head Screw	4	71	Bag Mount Tube	2
19-2	1/4" x 5/8" Carriage Bolt	4	72	Upper Hopper Frame (R.H)	1
20	Hex Bolt, 5/16" x 1-1/2"	2	74	Front Hopper Metal Bar	1
21	Height Adjustment Tube Assembly	1	75	Clevis Pin P, Ø10x15	2
22	Hair Cotter Pin, Ø2	4	76	Lower Hopper Frame Tube (R.H)	1
23	Spacer Bushing Ø16x3mm	2	77	Brush	4
24	Spacer for Axle	2	80	Adjustable Washer C	2
25	Dust Cover Assy	2	A2	Level Mount Bracket	1
26	Wheel Bushing	4	A6	Tow Bar	1
27	Hub Cap	2	A7	1/4"x3/4" Slotted Pan Head Screw	1
28	Nylon Nuts, 3/8", T 7mm	2	A8	Plate, Handle	1
29	Flat Washer, Ø10	6	A9	Quick Level Handle	1
30	Wheel & Tire Assy.(with bearing)	2	A10	Latch	1
31	Retaining Ring, Ø15	4	A11	Washer, Latch	1
32	Adj. Washer B	2	A12	Special Nut, Latch	1
33	Pinion Gear L.H.	1	A13	Cotter Pin, Handle	1
34	Dowel Pin (Drive)	2	A14	Spring	1
35	Adj. Washer A	4	A15	1/4" Flat Washer	4
36	Bushing	2	A16	Tie Bolt	2
37	Special Washer	2	A17	3/16" Nut	2
38	Hex Bolt, 1/4" x 1-1/2"	8	A18	Pull Rod	1
39	End Plate, Left Side	1	B1	Clevis Pin	2
40	Brush Shaft Bushing	2	B2	1/4" x 1-1/2" Carriage Bolt	2
41	Big Flat Washer	2	B3	Connecting Bracket, Rear Support	2
42	Dust Cover Retainer	2	B4	U Plate, Rear Support	1
43	Hex Bolt, 3/8" x 3"	2	B5	Adjust Plate, Rear Support	1
46	End Plate, Right Side	1	B6	Wing Nut, Rear Support	1
47	Wrapper	1	B7	1/4" x 5/8" Bolt	1
48	Pinion Gear R.H.	1	Q1	Tow Bar	1
49	Hex Bolt 1/4" x 1/2"	2	Q2	Tow Bar Bracket	2
50	Rear Support Brace	1	Q3	Cap	1
51	Brush Shaft	1	Q4	3/8" x 2" Bolt	2
55	Retainer, Brush (Double)	6	Q5	3/8" Lock Nut	2
57	Lock Nut, 3/16"	16	Q6	3/8" Flat Washer	1
				Main Sweeper Body	

## MAINTENANCE

- **Maintain your sweeper.** It is recommended that the general condition of any sweeper be examined before it is used. Keep your sweeper in good repair by adopting a program of conscientious repair and maintenance. If any abnormal vibrations or noise occurs, have the problem corrected before further use. Have necessary repairs made by qualified service personnel.

For replacement parts and technical questions, please call **1-218-943-6296**.

## WARRANTY

**One-year limited parts warranty**



TG  
PO BOX 203  
Miltona, MN 56354  
Made in Taiwan