



OWNER'S MANUAL & OPERATION INSTRUCTION



9000 Starting Watts
7000 Running Watts

PORTABLE GENERATOR

Visit Our Website at: <http://www.a-ipower.com>

Email Our Technical Support at: support@a-ipower.com

MODEL NUMBER
SUA9000E

FOR TECHNICAL QUESTIONS, PLEASE CALL 1-855-888-3598

SAVE THIS MANUAL

This manual contains important information regarding safety, operation, maintenance and storage of this product. Before use, read carefully and understand all cautions, warnings, instructions and product labels. Failure to do so could result in serious personal injury and/or property damage.

MADE IN CHINA
REV 7AA0700_A 08/2016

A-iPower Corp.
1477 E. Cedar St., STE B
Ontario, CA 91761, U.S.A.
www.a-ipower.com

TABLE OF CONTENTS

Introduction.....	3	Section 6 — Maintenance.....	13
Section 1 — Safety Rules.....	3	6.1 Maintenance Schedule.....	13
Section 2 — General Information.....	6	6.2 General Recommendations.....	13
2.1 Unpacking.....	6	6.2.1 Generator Maintenance.....	13
2.2 Assembly.....	6	6.2.2 To Clean the Generator.....	13
Section 3 —Features and Controls.....	7	6.2.3 Engine Maintenance.....	13
Section 4 — Preparation		6.2.4 Changing the Oil.....	14
 Before Operation.....	9	6.2.5 Replacing the Spark Plug.....	14
4.1 Adding Engine Oil.....	9	6.2.6 Spark Arrester.....	14
4.2 Adding Fuel.....	9	6.3 Service Air Filter.....	14
4.3 Grounding the Generator.....	9	6.4 Valve Clearance.....	15
4.4 Wattage Reference Guide	10	Section 7 — Storage.....	15
Section 5 — Operation.....	10	Section 8 — Troubleshooting.....	16
5.1 Starting the Engine.....	10	Section 9 — Parameter.....	18
5.2 Connecting Electrical Loads.....	12	Section 10 — Diagram.....	19
5.3 Stopping the Engine.....	12	Section 11 — Parts list and Diagram ..	20
5.4 Low Oil Level Shut down System.....	12	Section 12 — Warranties.....	24
5.5 High Altitude.....	12		

WARNING

The Engine Exhaust from this product contains chemicals known to the State of California to cause cancer or birth defects and other reproductive harm.

INTRODUCTION

Thank you for purchasing products from A-iPower. We appreciate your business.

This manual contains safety information to make you aware of hazards and risks associated with generator products and how to avoid them. It is important that you read and understand these instructions thoroughly before attempting to start or operate this equipment. **Save this original instruction for future reference.**

If any portion of this manual is not understood, Please call our Customer Service at 1-855-888-3598 for starting, operating and servicing procedures. We also strongly recommend you to instruct any other users who may operate the generator in an emergency.

The Emission Control System within this generator is warranted for standards set by the Environmental Protection Agency (EPA). Every effort has been made to ensure that information in this manual is both accurate and current. However A-iPower Corp. reserves all rights to change, alter, or otherwise to improve the generator and this documentation at any time without prior notice.

SECTION 1 SAFETY RULES



Read this manual carefully and become familiar with your generator. Know its applications, its limitations, and any hazards involved. Failure to follow instructions could result in serious injury or death.

Throughout this publication, and on tags and decals affixed to the generator, DANGER, WARNING, CAUTION and NOTE symbols are used to alert personnel with special instructions about a particular operation that may be hazardous if performed incorrectly, or carelessly Observe them carefully. Their definitions are as follows:



This is the safety alert symbol. It is used to alert you to potential personal injury hazards. Obey all safety messages that follow this symbol to avoid possible injury or death.

⚠ DANGER

DANGER indicates an imminently hazardous situation which, if not avoided, will result in death or serious injury.

⚠ WARNING

WARNING indicates a potentially hazardous situation which, if not avoided, could result in death or serious injury.

⚠ CAUTION

CAUTION indicates a potentially hazardous situation which, if not avoided, may result in minor or moderate injury.

CAUTION

CAUTION used without the safety alert symbol indicates a potentially hazardous situation which, if not avoided, may result in property damage.

NOTE

NOTE provides additional information that is useful for proper use and maintenance of this tool. If a NOTE is indicated, make sure it is fully understood.

Safety Symbols and Meanings



Toxic Fumes



Electrical Shock



Kickback



Fire



Explosion



Hot Surface



Flying Objects



Moving Parts

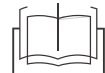

Owner's Manual

⚠ DANGER

Using a generator indoors **CAN KILL YOU IN MINUTES.**

Generator exhaust contains carbon monoxide. This is a poison you cannot see or smell.



NEVER use inside a home or garage, **EVEN IF** doors and windows are open.



Only use **OUTSIDE** and far away from windows, doors, and vents.

⚠ WARNING



A running engine gives off carbon monoxide, an odorless, colorless, poison gas. Breathing carbon monoxide could result in death, serious injury, headache, fatigue, dizziness, vomiting, confusion, seizures, nausea or fainting.

- Operate this product **ONLY** outdoors.
- Install a battery operated carbon monoxide alarm near the bedrooms.
- Keep exhaust gas away from entering a confined area through windows, doors, ventilation intakes, or other openings.
- **NEVER** operate this product inside any building, carport, porch, mobile equipment, marine applications, or enclosure, even if windows and doors are open.

⚠ WARNING The engine exhaust from this product, certain components in this product and related accessories contain chemicals known to the State of California to cause cancer, birth defects or other reproductive harm. Wash hands after handling.

⚠ WARNING This generator does not meet U.S. Coast Guard Regulation 33CFR-183 and can not be used on marine applications. Incorrect use of the appropriate U.S. Coast Guard approved generator could result in death or serious injury and/or property damage.

⚠ WARNING Starter cord kickback (rapid retraction) will pull hand and arm toward engine faster than you can let go which could cause broken bones, fractures, bruises, or sprains resulting in serious injury.



- When starting engine, pull cord slowly until resistance is felt and then pull rapidly to avoid kickback.
- NEVER start or stop engine with electrical devices plugged in and turned on.

⚠ WARNING Fuel and its vapors are extremely flammable and explosive which could cause burns, fire or explosion resulting in death, serious injury and/or property damage.



WHEN ADDING OR DRAINING FUEL

- Turn generator engine OFF and let it cool at least 2 minutes before removing fuel cap. Loosen cap slowly to relieve pressure in tank.
- Fill or drain fuel tank outdoors.
- DO NOT overfill tank, Allow space for fuel expansion.
- If fuel spills, wait until it evaporates before starting engine.
- Keep fuel away from sparks, open flames, pilot light, heat, and other ignition sources.
- Check fuel lines, tank, cap and fittings frequently for cracks or leaks. Replace if necessary.
- DO NOT light a cigarette or smoke.

⚠ WARNING

WHEN STARTING EQUIPMENT

- Ensure spark plug, muffler, fuel cap, and air cleaner are in place.
- DO NOT crank engine with spark plug removed.

WHEN OPERATING EQUIPMENT

- DO NOT operate this product inside any building, carport, porch, mobile equipment, marine applications, or enclosure.
- DO NOT tip engine or equipment at angle which cause fuel to spill.
- DO NOT stop engine by moving choke control to “OFF” position.

WHEN TRANSPORTING, OR REPAIRING EQUIPMENT

- Transport/move/repair with fuel tank EMPTY or with fuel valve OFF.
- DO NOT tip engine or equipment at angle which cause fuel to spill.
- Disconnect spark plug wire.

WHEN STORING FUEL OR EQUIPMENT WITH FUEL IN TANK

- Store away from furnaces, stoves, water heaters, clothes dryers, or other appliances that have light or other ignition source because they could ignite fuel vapors.

⚠ WARNING



Generator voltage could cause electrical shock or burn resulting in death or serious injury.

- Use approved transfer equipment to prevent back feed by isolating generator from electric utility workers.
- When using generator for backup power, notify utility company.
- Use a ground fault circuit interrupter in any damp or highly conductive area, such as metal decking or steel work.
- DO NOT touch bare wires or receptacles.
- DO NOT use generator with electrical cords which are worn, frayed, bare or otherwise damaged.
- DO NOT operate generator in the rain or wet weather.
- DO NOT handle generator or electrical cords while standing in water, while barefoot, or while hands or feet are wet.
- DO NOT allow unqualified persons or children to operate or service generator.

⚠ WARNING



Exhaust heat/gases could ignite combustibles, structures or damage fuel tank causing a fire, resulting in death, serious injury

and/or property damage. Contact with muffler area could cause burns resulting in serious injury.

- DO NOT touch hot parts and AVOID hot exhaust gases.
 - Allow equipment to cool before touching.
 - Keep at least 5 feet (1.5m) of clearance on all sides of generator including overhead.
 - It is violation of California Public Resource Code, Section 4442, to use or operate the engine on any frost - covered, brush - covered, or grass - covered land unless the exhaust system is equipped with a spark arrester, as defined in Section 4442, maintained in effective working order. Other states or federal jurisdictions may have similar laws.
- Contact the original equipment manufacturer, retailer, or dealer to obtain a spark arrester designed for the exhaust system installed on this engine.
- Replacement parts must be the same and installed in the same position as the original parts.

⚠ WARNING



Unintentional sparking could cause fire or electric shock resulting in death or serious injury.

WHEN ADJUSTING OR MAKING REPAIRS TO YOUR GENERATOR

- Disconnect the spark plug wire from the spark plug and place the wire where it cannot contact spark plug.

WHEN TESTING FOR ENGINE SPARK

- Use approved spark plug tester.
- DO NOT check for spark with spark plug removed.

⚠ WARNING

Starter and other rotating parts could entangle hands, hair, clothing, or accessories resulting in serious injury.

- NEVER operate generator without protective housing or covers.
- DO NOT wear loose clothing, jewelry or anything that could be caught in the starter or other rotating parts.
- Tie up long hair and remove jewelry.

⚠ CAUTION

Excessively high operating speeds could result in minor injury and/or generator damage.

Excessively low speeds impose a heavy load.

- DO NOT tamper with governor spring, links or other parts to increase engine speeds. Generator supplies correct rated frequency and voltage when running at governed speed.
- DO NOT modify generator in any way.

NOTE

Exceeding generators wattage/ amperage capacity could damage generator and/or electrical devices connected to it.

- DO NOT exceed the generator's wattage/ amperage capacity. See Don't Overload Generator in the Operation section.
- Start generator and let engine stabilize before connecting electrical loads.
- Turn electrical loads OFF and disconnect from generator before stopping generator.

NOTE

Improper treatment of generator could damage it and shorten its life.

- Use generator only for intended uses.
- If you have questions about intended use, please call our Customer Service at 1-855-888-3598.
- Operate generator only on level surfaces.
- DO NOT expose generator to excessive moisture, dust, dirt, or corrosive vapor.
- DO NOT insert any object through cooling slots.
- If connected devices overheat, to turn them off and disconnect them from generator.
 - or electrical output is lost.
 - or equipment sparks, smokes, or emits flames.
 - or unit vibrates excessively.
- to turn them off and disconnect them from generator.

SECTION 2 — SET UP

2.1 UNPACKING

- Set the carton on a rigid, flat surface.
- Remove everything from carton except generator.
- Open carton completely by cutting each corner from top to bottom.
- Leave generator on carton to install wheel kit.

2.1.1 PACKING CONTENTS

Wheel kit	2- 9.5 in wheel 2 -axle pin 2- pin 4- washer
Support Leg	1- support leg 2-flange bolt (M8x16) 2- nut (M8)
Other	1- engine oil 1.0 Quart 1- DC charge cable 1- spark torch 1- extension bar 1- high altitude kit

The above mentioned parts are packed in one box. Ensure you have all included items prior to assembly. If items are damaged or missing, call 1-855-888-3598.

2.2 ASSEMBLY

The generator requires some assembly prior to using it.

2.2.1 INSTALL THE SUPPORT LEG

The wheels are designed to greatly improve the portability of the generator.

NOTE The wheels are Not intended for over-the-road use.

Refer to Figure to install the support leg as shown. Unscrew nut (M8) on leg support, install bolt through the generator frame, secure the bolt tightly with wrench(not included).

2.2.2 INSTALL THE WHEEL KIT

Refer to Figure to install wheels as shown.

- Slide the axle through the wheel hub, then insert the flat washer.
- Slide the axle through the frame brackets.
- Bend the cotter pin tabs outward to lock the pin in place.

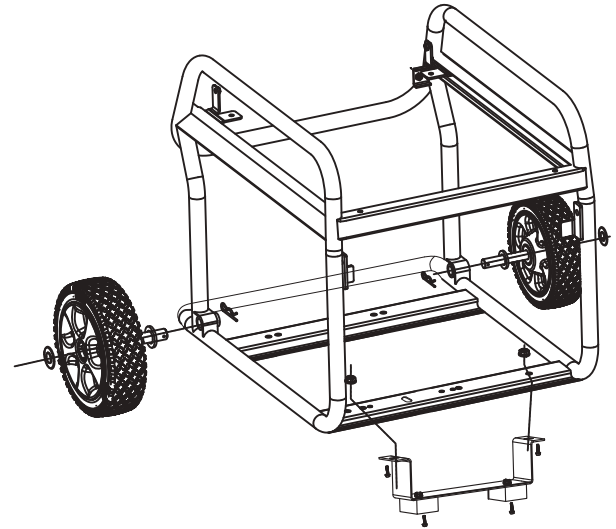

2.2.3 ADJUST SHOCK-ABSORBING SEAT

IMPORTANT: Before operating the generator the shock-absorbing seat (cushion) must be adjusted for proper clearance (figure 1). Loosen the lock nut and adjust the shock-absorbing seat so there is a 3mm gap between the top of the seat and the bottom of the motor bracket (figure 2). Re-tighten the lock nut.

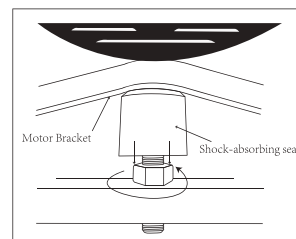

Figure 1

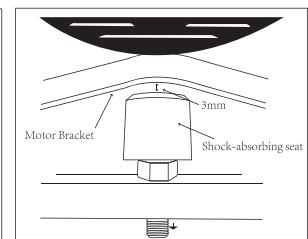

Figure 2

SECTION 3 —FEATURES AND CONTROLS



Read this Owner's Manual and safety rules before operating your generator. Compare the illustrations with your generator, to familiarize yourself with the locations of various controls and adjustments. Save this manual for future reference.

GENERATOR

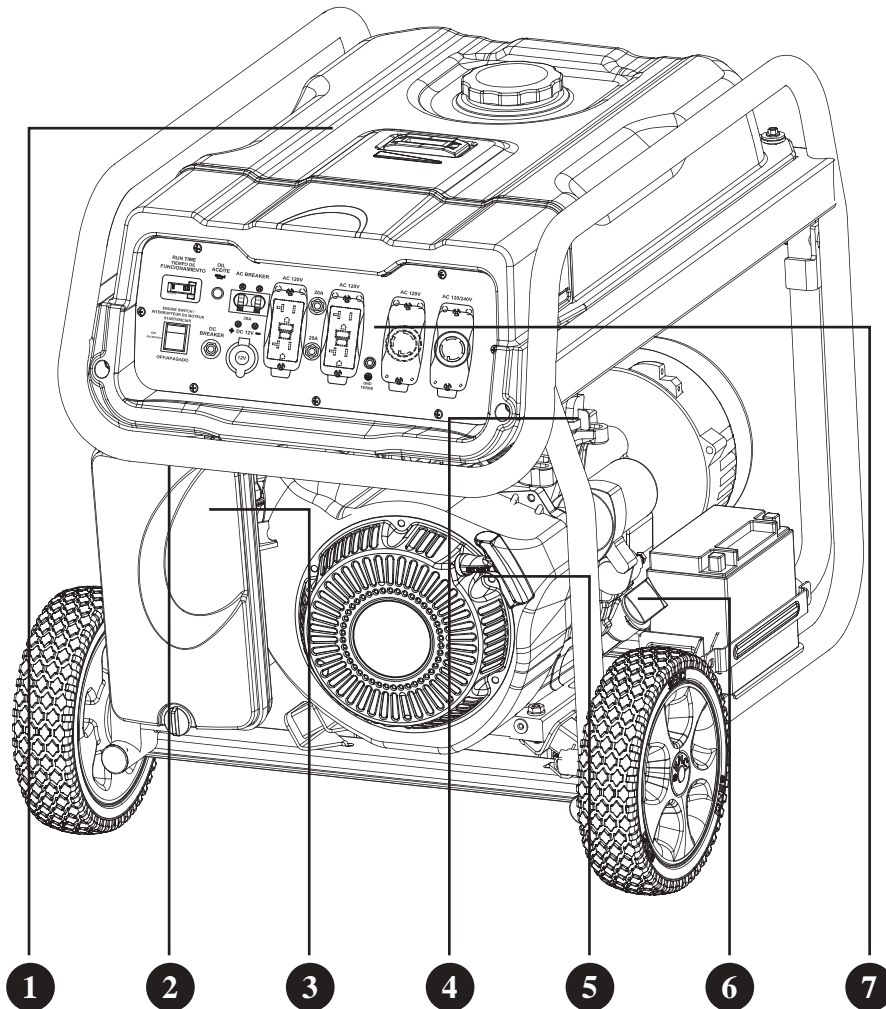

1. **Fuel Tank** - 7 gallon (25 L) capacity fuel tank.
2. **Choke Lever** - Controls choke valve. Used when starting a cold engine.
3. **Air Filter** - Protects the engine by filtering dust and debris from the intake air.
4. **Fuel Valve** - Used to turn fuel supply on and off to engine.
5. **Recoil Starter** - Used to manually start the engine.
6. **Oil Filler Cap** - Check and fill engine oil level.
7. **Control Panel** - See "Power Panel" section on Page 8.

NOTE We are always working to improve our products. Therefore, final product may vary from images shown. A-iPower reserves the right to change features, specifications without notice for further improvements of products.

CONTROL PANEL

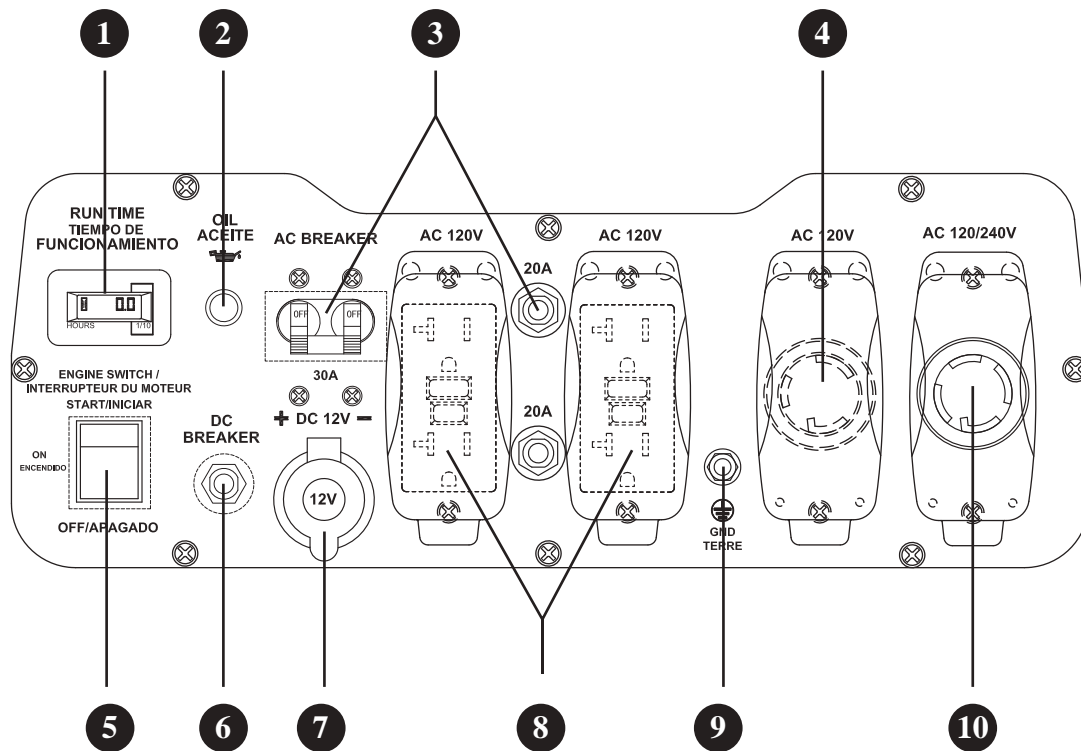

- 1. Hour Meter** - Monitor run time and schedule maintenance intervals
- 2. Low Oil Alarm** - Alarm when low oil is detected
- 3. Circuit Breaker** - The circuit breaker protects the generator against electrical overloads. The rating of the breaker and the load it protects are marked near the breaker. Should any of the Circuit Breakers trip, the generator will stop the electricity output. If this happens, unplug all loads from the generator. Allow the generator to cool down. Then, press the tripped Circuit Breaker, restart the engine, and re-attach loads.
- 4. 120V AC 30A L5-30R** - Used to supply electrical power for the operation of 120V AC, 20A, single phase 60HZ electrical loads.
- 5. Engine Switch** - Set this switch to ON before starting engine. Set switch to OFF to shut off engine.
- 6. DC Circuit Breaker** – protect DC output, turn off automatically if the current exceeds 8A.
- 7. 12V DC OUTPUT** – used for battery charging.
- 8. GFCI 120V 20A 5-20R** - Used to supply electrical power for the operation of 120V AC, 20A, single phase 60HZ electrical loads.
- 9. Ground Terminal** - Prior to each use, set up the ground wire (not included) connection to the Grounding Terminal to properly ground the Generator.
- 10. 120/240 VAC 30A L14-30R Twist-lock Receptacle** - Used to supply electrical power for the operation of 120V AC and/or 240VAC, 30A, single phase 60Hz electrical loads.

SECTION 4 — PREPARATION BEFORE OPERATION

4.1 ADDING ENGINE OIL

All oil should meet minimum American Petroleum Institute (API) Service Class SJ, SL or better. Use no special additives. Select the oil's Viscosity grade according to the expected operating temperature (also see chart).

The SAE Viscosity Chart

Above 40 °F, use SAE 30

Between 40 °F to 10 °F, use 10W-30

Below 10 °F, use synthetic 5W-30

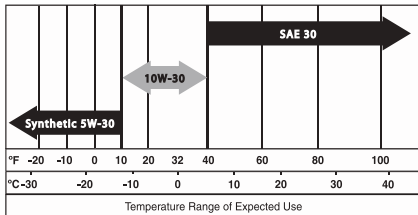

NOTE

Improper treatment of generator could damage it and shorten its life. DO NOT attempt to crank or start the engine before it has been properly serviced with the recommended oil. This could result in an engine failure.

- Place generator on a flat, level surface.
- Clean area around oil fill and remove oil fill cap and dipstick. Wipe dipstick clean.
- Slowly fill engine with oil through the oil filter open until it reaches the full mark on the dipstick. Stop filling occasionally to check oil level. Be careful do not over fill.
- Install oil fill cap and finger tighten securely.
- Check engine oil level before starting each time thereafter.

4.2 ADDING FUEL

⚠ DANGER

Never fill tank indoors. Never fill fuel tank when engine is running or hot. Turn generator engine OFF and allow engine to cool entirely before filling fuel tank. Avoid spilling gasoline on HOT engine. Keep fuel away from sparks, open flames, pilot lights, heat, and other ignition sources. DO NOT light a cigarette or smoke when filling the fuel tank. Fuel is highly FEAMMABLE and its vapors are EXPLOSIVE.

- Use regular UNLEAD gasoline with the generator engine. Do not use any fuel with more than 10% added ethanol, and never use E85 fuel.
- Do not mix oil with gasoline.
- Install fuel cap and wipe up any spilled gasoline.

⚠ CAUTION



Do not overfill the fuel tank. Allow space for fuel expansion. IF the fuel tank is overfilled, fuel can overflow onto a HOT engine and cause FIRE or EXPLOSION. If fuel spills, wait until it evaporates before starting engine. Check fuel lines, tank, cap and fittings frequently for cracks or leaks. Replace if necessary.

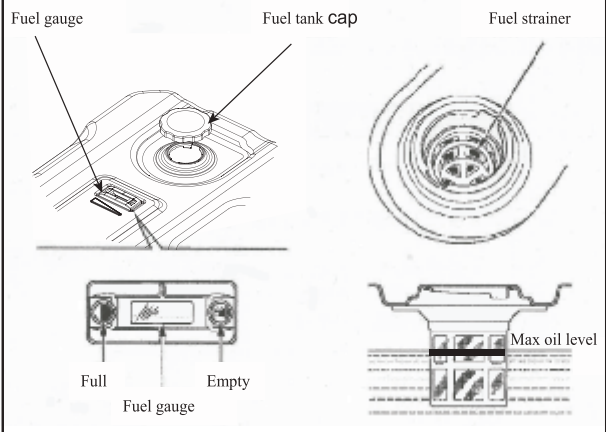

IMPORTANT: It is important to prevent gum deposits from forming in fuel system parts such as the carburetor, fuel hose or tank during storage. Alcohol-blended fuels (called gasohol), ethanol or methanol) can attract moisture, which leads to separation and formation of acids during storage. Acidic gas can damage the fuel system. So the fuel should be emptied before storage of 30 days or longer. See the "Storage" section. Never use engine or carburetor cleaner products in the fuel tank as permanent damage may occur.

4.3 GROUNDING THE GENERATOR

The national Electrical Code requires that the frame and external electrically conductive part of this generator be properly connected to an approved earth ground.

Local electrical codes may also require proper grounding of the unit. For that purpose, connecting a No. 10 AWG (American Wire Gauge) stranded copper wire to the grounding lug and to an earth-driven copper or brass grounding rod (electrode) provides adequate protection against electrical shock. However, local codes may vary widely. Consult with a local electrician for grounding requirement in the area.

Proper grounding of the generator will help prevent electrical shock in the event of ground fault condition in the generator or in connected electrical devices. Proper grounding also helps dissipate static electricity, which often builds up in ungrounded devices.

4.4 WATTAGE REFERENCE GUIDE

Wattage Reference Guide		
Tool or Appliance	Running* (Rated) Watts	Additional Starting (Surge) Watts
Essentials		
Light Bulb - 75 watt	75	—
Furnace Fan Blower - 1/2 HP	800	2350
Sump Pump - 1/3 HP	800	1300
Refrigerator/Freezer	700	2200
Water Well Pump - 1/2 HP	1000	2100
Heating/Cooling		
Window AC - 10,000 BTU	1200	3600
Humidifier - 13 Gal	175	—
Central AC - 24,000 BTU	3800	11400
Kitchen		
Microwave Oven - 1000 Watt	1000	—
Coffee Maker	1000	—
Electric Stove - 8" Element	2100	—
Toaster	850	—
Family Room		
DVD/CD Player	100	—
VCR	100	—
Stereo Receiver	450	—
Color Television - 27 in	500	—
Personal Computer w/17 in monitor	800	—
Other		
Security System	500	—
AM/FM Clock Radio	100	—
Garage Door Opener - 1/2 HP	875	2350
Electric Water Heater	4700	11700
DIY/Job Site		
Quartz Halogen Work Light	1000	—
Airless Sprayer - 1/3 HP	600	1200
Reciprocating Saw	960	—
Electric Drill - 1/2 HP, 5.4 Amps	600	900
Circular Saw - 7-1/4 in	1400	2300
Miter Saw - 10 in	1800	1800
Table Planer - 6 in	1800	1800
Table Saw/Radial Arm Saw - 10 in	2000	2000
Air Compressor - 1 HP	1600	4500

SECTION 5 — OPERATION

5.1 STARTING THE ENGINE

⚠ WARNING Never start or stop engine with electrical devices plugged into the receptacles AND devices turned on.

Unplug all electrical loads from the unit's receptacles before starting the engine.

Make sure the unit is in a level position.

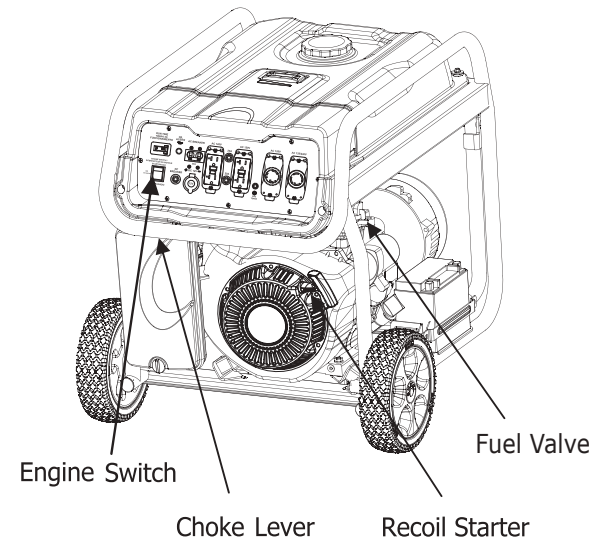

Turn engine switch to ON position.

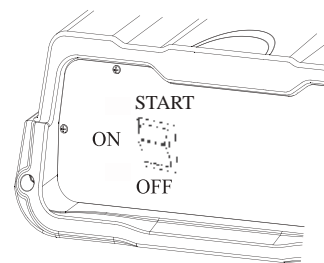

Turn Fuel Valve to ON position.

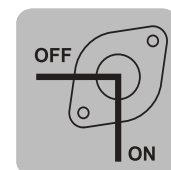
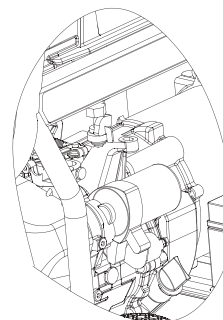

Move engine choke lever to the CHOKE position.

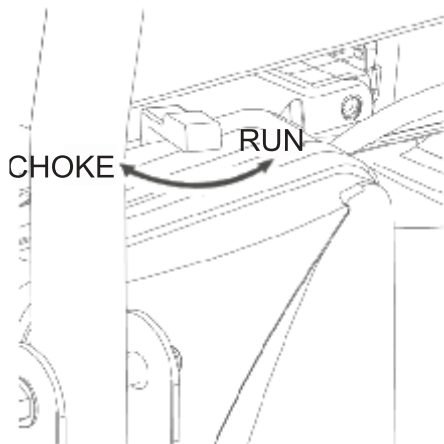

Push the switch to “START” position, hold in start position until generator start.
Caution: to prolong the life of starter components, DO NOT hold for more than 10 seconds. Pause and retry as necessary. After generator starts, release switch and it will return to the “ON” position automatically.

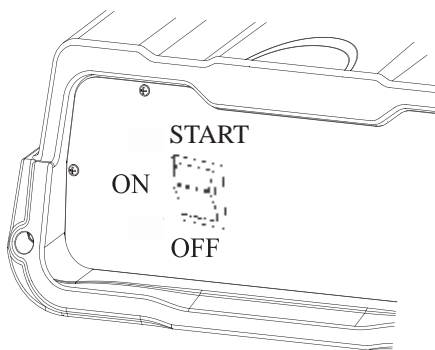

When engine starts, move choke lever to 1/2-CHOKE position until engine runs smoothly and then fully into RUN position. If engine falters, move choke back out to 1/2-CHOKE position until engine runs smoothly and then fully into RUN position.

NOTE If battery is discharged, use manual starting instructions.

NOTE If engine starts, but does not continue to run, move choke lever to the CHOKE position and repeat starting instructions.

WARNING Starter cord kickback (rapid retraction) will pull hand and arm toward engine faster than you can let go which could cause broken bones, fractures, bruises, or sprains resulting in serious injury.
When starting engine, pull cord slowly until resistance is felt and then pull rapidly to avoid kickback.
Never start or stop engine with electrical devices plugged in and turned on.

NOTE If engine fails to start after 3 pulls, or if unit shut down during operation, make sure unit is on a level surface and check for proper oil level in crankcase. This unit may be equipped with a low oil protection device. If so, oil must be checked at proper level for engine to start and run.

WARNING Exhaust heat/ gases could ignite combustible, structures or damage fuel tank causing a fire, resulting in death, serious injury and/or property damage. Contact with muffler area could cause burn resulting in serious injury.
DO NOT touch hot part and AVOID hot exhaust gases.
Allow equipment to cool before touching.
Keep at least 5 feet (152 cm) of clearance on all sides of generator including overhead.
Contact the original equipment manufacturer, retailer, or dealer to obtain a spark arrester designed for the exhaust system installed on this engine.
Replacement parts must be the same and installed in the same position as the original parts.

IMPORTANT: Do not overload the generator. Also, do not overload individual panel receptacles. These outlets are protected against overload with push-to-reset-type circuit breakers. If amperage rating of any circuit breaker is exceeded, that breaker opens and electrical output to that receptacle is lost.

5.2 CONNECTING ELECTRICAL LOADS

- Let engine run stable and warm up for a few minutes after starting.
- Plug in and turn on the desired 120 and/or 240 Volt AC, single phase, 60 Hz electrical loads.
- Add up the rated watts (or amps) of all loads to be connected at one time. This total should not be greater than (a) the rated wattage/amperage capacity of the generator or (b) circuit breaker rating of the receptacle supplying the power.

NOTE

DO NOT connect 240 Volt loads to the 120 Volt duplex receptacles, and do not do vice versa also. DO NOT connect 3 phase loads to the generator. DO NOT connect 50 Hz loads to the generator.

NOTE

- Start generator and let engine stabilize before connecting electrical loads.
- Connect electrical loads in OFF position then turn ON for operation.
 - Turn electrical loads OFF and disconnect from generator before stopping generator.
 - DO NOT overload Generator Capacity

NOTE

Exceeding generators wattage/amperage capacity could damage generator and/or electrical devices connected DO NOT exceed the generator's wattage/amperage capacity.

- Overloading a generator in excess of its rated wattage capacity can result in damage to the generator and to connected electrical devices. Observe the following to prevent overloading the unit:
 - Add up the total wattage of all electrical devices to be connected at one time. This total should NOT be greater than the generator's wattage capacity.

The rated wattage of lights can be taken from light bulbs. The rated wattage of tools, appliances and motors can usually be found on a data label

NOTE

or decal affixed to be the device. If the appliance, tool or motor does not give wattage, multiply volts times ampere rating to determine watts:

$$\text{Volts} \times \text{Amps} = \text{Watts}$$

Some electric motors, such as induction types, require about three times more watts of power for starting than for running. This surge of power lasts only a few seconds when starting such motors. Make sure to allow for high starting wattage when selecting electrical devices to connect to the generator:

- Figure the watts needed to start the largest motor.
- Add to that figure the running watts of all other connected loads.

The "WATTAGE REFERENCE GUIDE" on Page 10 helps to determine how many items the generator can operate at one time.

5.3 STOPPING THE ENGINE

- Shut off all loads then unplug the electrical cables from generator panel receptacles. Never start or stop the engine with electrical devices plugged in and turned on.
- Let engine run at no-load for several minutes to stabilize the internal temperatures of engine and generator.
- Move Engine switch to OFF position.
- Close fuel valve.

5.4 LOW OIL LEVEL SHUT DOWN SYSTEM

The engine is equipped with a low oil level sensor that shuts down the engine automatically when the oil level drops below a specified level. If the engine shuts down by itself and the fuel tank has enough gasoline, check engine oil level.

5.5 HIGH ALTITUDE OPERATION

At high altitudes over 3,000 feet, the engine carburetor and any other parts that control the fuel-air ratio will be affected, which will decrease performance, increase fuel consumption and increase emission. Proper operation can be ensured by installing an altitude kit by a qualified mechanic when use at altitude higher than 3,000 feet. Refer to the altitude kit and operation instruction (provided) when needed.

SECTION 6 — MAINTENANCE

6.1 MAINTENANCE SCHEDULE

Follow the calendar intervals shown below. More frequent service is required when operating in adverse conditions.

First 5 Hours
<ul style="list-style-type: none">• Change engine oil
Every 8 Hours or Daily
<ul style="list-style-type: none">• Clean debris• Check engine oil level
Every 25 Hours or Yearly
<ul style="list-style-type: none">• Clean engine air filter
Every 50 Hours or Yearly
<ul style="list-style-type: none">• Change engine oil
Yearly
<ul style="list-style-type: none">• Replace engine air filter• Service fuel valve• Service spark plug• Inspect muffler and spark arrester• Clean cooling system

6.2 GENERAL RECOMMENDATIONS

The warranty of the generator does not cover items that have been subjected to operator abuse or negligence. To receive full value from the warranty, the operator must maintain the generator as instructed in this manual.

Some adjustments will need to be made periodically to properly maintain the generator.

All adjustments in the “MAINTENANCE” section should be made at least once each season. Follow the requirements in the “Maintenance Schedule”.

NOTE	Once a year replace the spark plug and replace the air filter. A new spark plug and clean air filter assure proper fuel-air mixture and help the engine run better and last longer.
-------------	---

6.2.1 GENERATOR MAINTENANCE

Generator maintenance consists of keeping the unit clean and dry. Operate and store the unit in a clean dry environment where it will not be exposed to excessive dust, dirt, moisture or any corrosive vapors. Cooling air slots in the generator must not become clogged with snow, leaves, or any other foreign material. Check the cleanliness of the generator frequently and clean when dust, dirt, oil, moisture or other foreign substances are visible on its exterior surface.

CAUTION	Never insert any object or tool though the air cooling slots, even if the engine is not running.
----------------	--

NOTE	DO NOT use a garden hose to clean generator. Water can enter the engine fuel system and cause problem. In addition, if water enters the generator though cooling air slots, some water will be retained in voids and crevices of the rotor and stator winding insulation. Water and dirt buildup on the generator internal windings will eventually decrease the insulation resistance of these windings.
-------------	---

6.2.2 TO CLEAN THE GENERATOR

- Use a damp cloth to wipe exterior surfaces clean.
- A soft, bristle brush may be used to loosen caked on dirt, oil etc.
- A vacuum cleaner may be used to pick up loose dirt and debris.
- Low pressure air (not to exceed 25 psi) may be used to blow away dirt. Inspect cooling air slots and openings on the generator. These openings must be kept clean and unobstructed.

6.2.3 ENGINE MAINTENANCE

DANGER	When working on the generator, always disconnect spark plug wire from spark plug and keep wire away from spark plug.
---------------	--

6.2.4 CHANGING ENGINE OIL

Change engine oil after the first five hours of operation, then every 50 hours thereafter. If running this unit under dirty or dusty conditions, or in extremely hot weather, to change the oil more often.

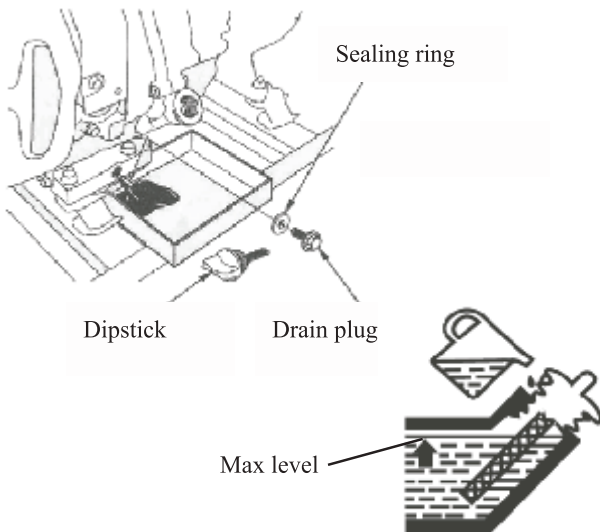

CAUTION Hot oil may cause burns. Allow engine to cool before draining oil. Avoid prolonged or repeated skin exposure with used oil. Thoroughly wash exposed areas with soap.

Use the following instructions to change the oil while the engine is still warm:

- Clean area around oil drain plug.
- Remove oil drain plug from engine and oil fill plug to drain oil completely into a suitable container.
- When oil has completely drained, install oil drain plug and tighten securely.
- Fill engine with recommended oil. (See “Before Starting the Generator” for oil recommendations).
- Wipe up any spilled oil.
- Dispose of used oil at a proper collection center.

6.2.5 SPARK PLUG MAINTENANCE

Use spark plug F6TC, F7TC, BPR4ES or Champion RN14YC. Replace the plug once each year. This will help the engine start easier and run better.

- Stop the engine and pull the spark plug wire off of the spark plug.
- Clean the area around the spark plug and remove it from the cylinder head.
- Set the spark plug’s gap to 0.70-0.80 mm (0.028-0.031 in.). Install the correctly gapped spark plug into the cylinder head and torque to 15 ft/lbs.

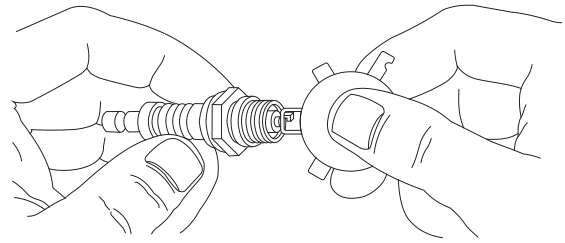

6.2.6 SPARK ARRESTER

- Shut off generator and allow the engine and muffler to cool down completely before servicing spark arrester (located on the back of the muffler).
- Remove the clamp and spark arrester screen.
- Clean the spark arrester screen with a small wire brush.
- Replace the spark arrester if it is damaged.
- Installation of the spark arrester screen is the reverse of the removal.

6.3 AIR FILTER MAINTENANCE

The engine will not run properly and may be damaged if using a dirty air filter. Replace the air filter once a year. Clean or replace more often if operating under dusty conditions.

- Remove air filter cover.
- Wash in soapy water. Squeeze filter dry in clean cloth (DO NOT TWIST).
- May drop a bit of engine-oil to avoid ice blocked during winter season.
- Clean air filter cover before re-installing it.

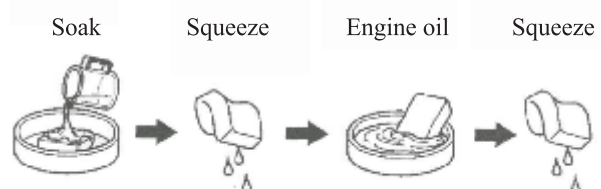
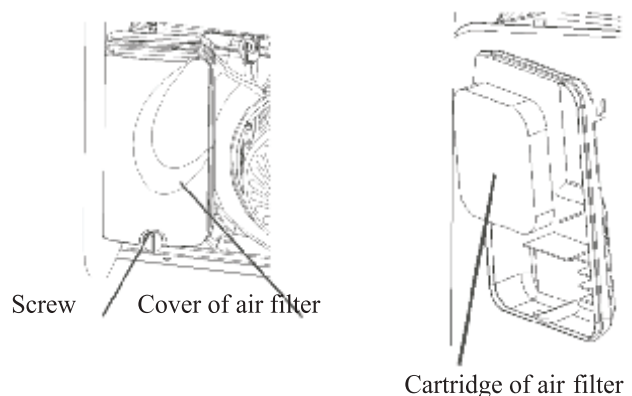

6.4 VALVE CLEARANCE

After the first 50 hours of operation, check the valve clearance in the engine and adjust if necessary.

Valve Clearance

- Intake: 0.10-0.15mm (0.004-0.006 in)
- Exhaust: 0.15-0.20mm (0.006-0.008 in)

Important: If feeling uncomfortable about doing this procedure or the proper tools are not available, please take the generator to the nearest service center to have the valve clearance adjusted. This is a very important step to ensure longest life for the engine.

SECTION 7 — STORAGE

7.1 GENERAL

The generator should be started at least once every seven days and be allowed to run at least 30 minutes. If this cannot be done and the unit must be stored for more than 30 days, use the following information as a guide to prepare it for storage.

⚠ DANGER NEVER store engine with fuel in tank indoors or in enclosed, poorly ventilated areas where fumes may reach an open flame, spark or pilot light as on a furnace, water heater, clothes dryer or other gas appliance.

⚠ CAUTION Avoid spray from spark plug holes when cranking engine.

⚠ DANGER Drain fuel into approved container outdoors, away from open flame. Be sure engine is cool. Do not smoke.

7.2 LONG TERM SHORTAGE INSTRUCTIONS

It is important to avoid gum deposits from forming in essential fuel system parts such as the carburetor, fuel hose or tank during storage. Also, experience indicates that alcohol-blended fuels (called gasohol, ethanol or methanol) can attract moisture, which leads to separation and formation of acids storage. Acidic gas can damage the fuel system of an engine while in storage.

To avoid engine problems, the fuel system should be emptied before storage of 30 days or longer, as follows:

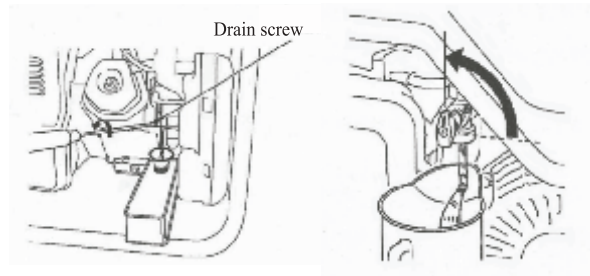

- Remove all gasoline from the fuel tank.
- Start and run engine until engine stops from lack of fuel.
- While engine is still warm, drain oil from crankcase. Refill with recommended grade.
- Remove spark plugs and pour about 1/2 ounce (15 ml) of engine oil into the cylinders. Cover spark plug hole with rag. Pull the recoil starter a couple times to lubricate the piston rings and cylinder bore.

7.3 OTHER STORAGE TIPS

- Do not store gasoline from one season to another.
- Replace the gasoline can if it starts to rust. Rust and/or dirt in the gasoline will cause problems with the carburetor and fuel system.
- If possible, store the unit indoors and cover it to give protection from dust and dirt. **BE SURE TO EMPTY THE FUEL TANK.**
- If it is not practical to empty the fuel tank and the unit is to be stored for some time, use a commercially available fuel stabilizer added to the gasoline to increase the life of the gasoline.
- Cover the unit with a suitable protective cover that does not retain moisture.

⚠ DANGER NEVER cover the generator while engine and exhaust area are warm.

- Install and tighten spark plugs. Do not connect spark plug wires.
- Clean the generator outer surfaces. Check that cooling air slots and openings on generator are open and unobstructed.
- Store the unit in clean, dry place.

SECTION 8 — TROUBLESHOOTING

Problem	Possible Causes	Probable Solutions
Engine will not start	FUEL RELATED: <ol style="list-style-type: none"> No fuel in tank or fuel valve is in "OFF" position. Low quality, stale, dirty or deteriorated gasoline. Choke not in START position, cold engine. Carburetor not primed. Dirty fuel passageways. Carburetor needle stuck. Fuel can be smelled in the air. Too much fuel in chamber. This can be caused by the carburetor needle sticking. Intake valve stuck open or closed. Clogged Fuel Filter. 	FUEL RELATED: <ol style="list-style-type: none"> Fill fuel tank with fresh 87+ octane unleaded stabilizer-treated gasoline and turn fuel valve to "ON" position. Do not use gasoline with more than 10% ethanol (E15, E20, E85, etc.). Drain fuel tank and carburetor; fill with fresh fuel. Move Choke to START position. Pull on Starter Handle to prime. Clean out passageways using fuel additive. Heavy deposits may require further cleaning. Gently tap side of carburetor float chamber with screwdriver handle. Turn Choke to RUN position. Remove spark plug and pull the start handle several times to air out the chamber. Reinstall spark plug and set Choke to START position. Call customer service: 1-855-888-3598. Replace Fuel Filter.
	IGNITION (SPARK) RELATED: <ol style="list-style-type: none"> Spark plug cap not connected securely. Spark plug electrode wet or dirty. Incorrect spark plug gap. Spark plug cap broken. Incorrect spark timing or faulty ignition system. 	IGNITION (SPARK) RELATED: <ol style="list-style-type: none"> Connect spark plug cap properly. Clean spark plug. Correct spark plug gap. Replace spark plug cap. Have qualified technician diagnose/repair ignition system.
	COMPRESSION RELATED: <ol style="list-style-type: none"> Cylinder not lubricated. Problem after long storage periods. Loose or broken spark plug. (Hissing noise will occur when trying to start.) Loose cylinder head or damaged head gasket. (Hissing noise will occur when trying to start.) Engine valves or tappets mis-adjusted or stuck. 	COMPRESSION RELATED: <ol style="list-style-type: none"> Pour tablespoon of oil into spark plug hole. Crank engine a few times and try to start again. Tighten spark plug. If that does not work, replace spark plug. If problem persists, may have head gasket problem, see #3. Tighten head. If that does not remedy problem, replace head gasket. Have qualified technician adjust/repair valves and tappets.
	ENGINE OIL RELATED: <ol style="list-style-type: none"> Low engine oil. Engine mounted on slope, triggering low oil shutdown. 	ENGINE OIL RELATED: <ol style="list-style-type: none"> Fill engine oil to proper level. Check engine oil before EVERY use. Operate engine on level surface. Check engine oil level.
Engine "hunts" or falters	<ol style="list-style-type: none"> Carburetor is running too rich or too lean. Clogged or dirty fuel filter. 	<ol style="list-style-type: none"> Call Customer Service: 1-855-888-3598. Clean or replace fuel filter.
Engine lacks power	<ol style="list-style-type: none"> Cylinder pressure is low. Dirty air filter. 	<ol style="list-style-type: none"> Call Customer Service: 1-855-888-3598. Clean or replace fuel filter.

Problem	Possible Causes	Probable Solutions
Engine misfires	<ol style="list-style-type: none"> 1. Spark plug cap loose. 2. Incorrect spark plug gap or damaged spark plug. 3. Defective spark plug cap. 4. Old or low quality gasoline. 5. Incorrect compression. 	<ol style="list-style-type: none"> 1. Check wire connections. 2. Re-gap or replace spark plug. 3. Replace spark plug cap. 4. Use only fresh 87+ octane stabilizer-treated unleaded gasoline. Do not use gasoline with more than 10% ethanol (E15, E20, E85, etc.). 5. Diagnose and repair compression. (Use Engine will not start: COMPRESSION RELATED section.)
Engine stops suddenly	<ol style="list-style-type: none"> 1. Fuel tank empty or full of impure or low quality gasoline. 2. Low oil shutdown. 3. Defective fuel tank cap creating vacuum, preventing proper fuel flow. 4. Faulty magneto. 5. Disconnected or improperly connected spark plug cap. 	<ol style="list-style-type: none"> 1. Fill fuel tank with fresh 87+ octane stabilizer-treated unleaded gasoline. Do not use gasoline with more than 10% ethanol (E15, E20, E85, etc.). 2. Fill engine oil to proper level. Check engine oil before EVERY use. 3. Test/replace fuel tank cap. 4. Have qualified technician service magneto. 5. Secure spark plug cap.
Engine stops when under heavy load	<ol style="list-style-type: none"> 1. Dirty air filter 2. Engine running cold. 	<ol style="list-style-type: none"> 1. Clean or replace element. 2. Allow engine to warm up prior to operating equipment.
Engine knocks	<ol style="list-style-type: none"> 1. Old or low quality gasoline. 2. Engine overloaded. 3. Incorrect spark timing, deposit buildup, worn engine, or other mechanical problems. 	<ol style="list-style-type: none"> 1. Fill fuel tank with fresh 87+ octane stabilizer-treated unleaded gasoline. Do not use gasoline with more than 10% ethanol (E15, E20, E85, etc.). 2. Do not exceed equipment's load rating. 3. Have qualified technician diagnose and service engine.
Engine backfires	<ol style="list-style-type: none"> 1. Impure or low quality gasoline. 2. Engine too cold. 3. Intake valve stuck or overheated engine. 4. Incorrect timing. 	<ol style="list-style-type: none"> 1. Fill fuel tank with fresh 87+ octane stabilizer-treated unleaded gasoline. Do not use gasoline with more than 10% ethanol (E15, E20, E85, etc.). 2. Use cold weather fuel and oil additives to prevent backfiring. 3. Have qualified technician diagnose and service engine. 4. Check engine timing.
Generator shuts down during operation	<ol style="list-style-type: none"> 1. Out of fuel. 2. Low oil level. 	<ol style="list-style-type: none"> 1. Fill fuel tank. 2. Fill crankcase to the proper level. Place generator on a flat, level surface.
Generator cannot supply enough power or overheating	<ol style="list-style-type: none"> 1. Generator is overloaded. 2. Insufficient ventilation. 	<ol style="list-style-type: none"> 1. Review load and adjust, see "xx". 2. Check for air restriction. Move to a well ventilated area.
No AC output	<ol style="list-style-type: none"> 1. Cable not properly connected. 2. Circuit breaker is open. 3. Faulty brush assembly. 4. Faulty AVR. 5. Loose wiring. 6. Other. 	<ol style="list-style-type: none"> 1. Check all connections. 2. Reset circuit breaker. 3. Replace brush assembly. 4. Replace AVR. 5. Inspect and tighten wiring connections. 6. Contact Customer Service at 1-855-888-3598.
Generator gallops	<ol style="list-style-type: none"> 1. Engine governor defective. 	<ol style="list-style-type: none"> 1. Contact Customer Service at 1-855-888-3598.
Repeated circuit breaker tripping	<ol style="list-style-type: none"> 1. Overload. 2. Faulty cords or device. 	<ol style="list-style-type: none"> 1. Review load and adjust. See "Wattage Reference Guide" on Page 10. 2. Check for damaged, bare or frayed wires. Replace defective device.

SECTION 9 — PARAMETER

Specification

Generator	Model Number	SUA9000E
	Starting Watts	9000
	Running Watts	7000
	AC Load	120/240V
	Frequency	60Hz
	Running VAC Amperage	29.0A
	Phase	Single
	IP Class	21
	Power Factor	1.0
	Receptacle	ONE - 120V AC 30A L5-30R FOUR - 120V 20A NEMA 5-20R GFCI Outlet ONE - 120/240V 30A NEMA L14-30R Outlet
Engine	Displacement	420cc / 14hp
	Starting Method	Electric
	Cooling System	Horizontal Single Cylinder 4 Stroke OHV
	Fuel Tank Capacity	7Gl. (25L)
	Engine Oil Capacity	1.0Qt. (1.0L)
	Run time @ 50% Load (Hrs)	9.5 Hrs
	Run time @ 100% Load (Hrs)	6.5 Hrs
	Noise Level	76 dBA at 23ft (7m)

SECTION 10 — DIAGRAM

SUA9000E

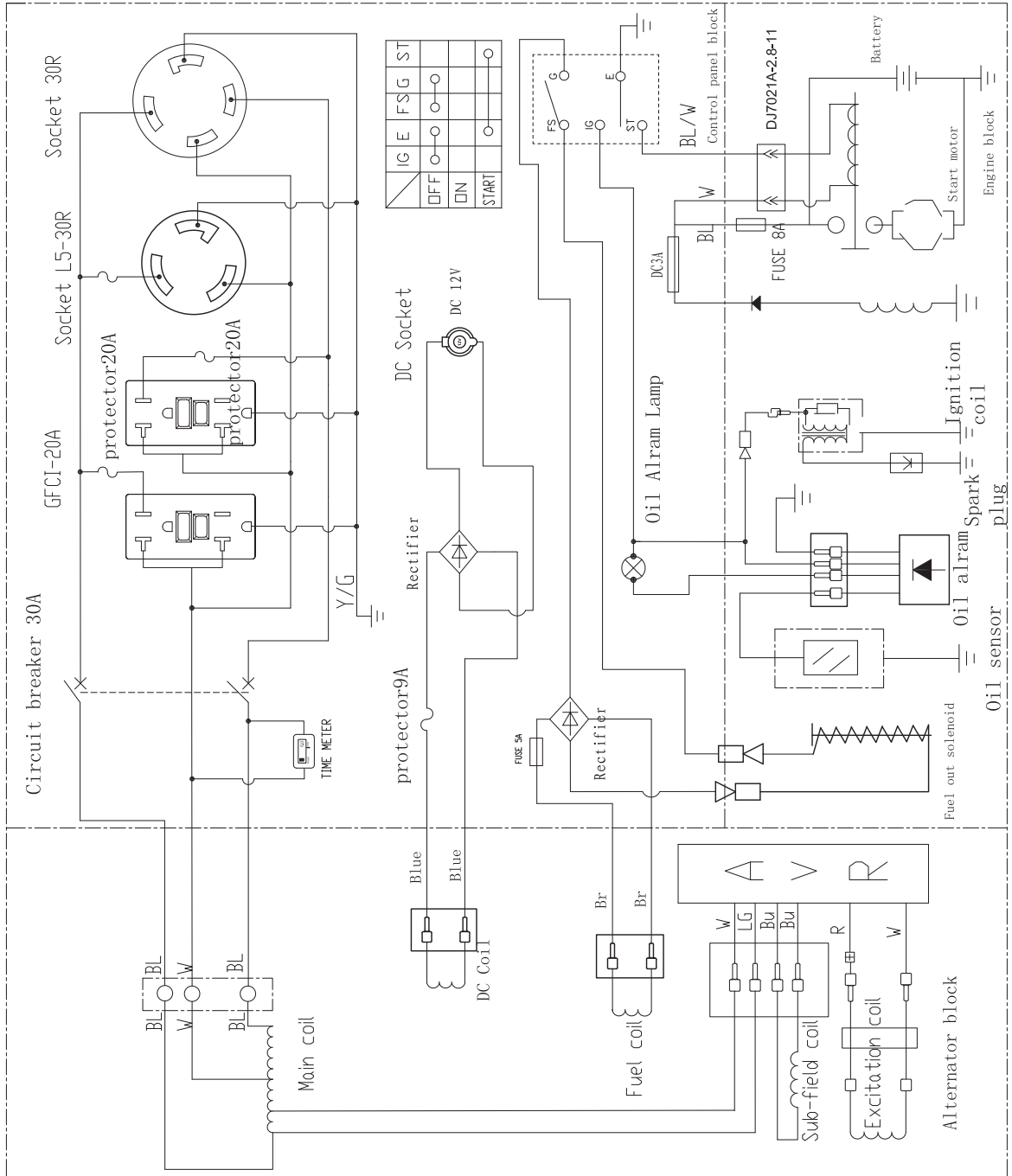

SECTION 11— PARTS LIST AND DIAGRAM

GENERAL PARTS LIST

Part	Discription	QTY	Part	Discription	QTY
1	Nut, Flange	4	32	Hexagon Blot	2
2	Nut, Flange	4	33	Bolt,Flange	4
3	Shock Absorbing Mount	4	34	Motor Bracket	1
4	Washer, Plain	4	35	Wiring Borad Assy	1
5	Wheel Assy	2	36	Bolt,Flange	5
6	Axle	2	37	Carbon Brush	1
7	Clip, Dowel Pin	1	38	AVR	1
8	Positive Charging Wire	1	39	Motor Cover, Rear	1
9	Negative Charging Wire	1	40	Washer, Plain	1
10	Bolt,Flange	9	41	Bolt,Flange	1
11	Battery Plate	1	42	Stator	1
12	Battery	1	43	Rotor	1
13	Ground Terminal	1	44	Bolt,Flange	1
14	Wave Spring	1	45	Bracket,Muffler	1
15	Nut, Flange	1	46	Muffler Assy	1
16	Bolt,Flange	4	47	Wahser, Muffler	1
17	Support Rubber	2	48	Hexagon Nut	2
18	Support Assy	1	49	Spring Washer	2
19	Bolt,Flange	2	50	Muffler Block	1
20	Nylon Nut	2	51	Wahser, Muffler	1
21	Handlebar Components	1	52	Control Pannel Assy	1
22	Handlebar Dowel Pin	2	53	Bolt,Flange	6
23	Handlebar Rubber Cover	2	54	Gasket,Fuel Tank	6
24	Handlebar Grip	1	55	Bolt,Flange	2
25	Gasoline Engine	1	56	Frame Components	1
26	Air Deflector,Down	1	57	Fuel Tank Assy	1
27	Bolt,Flange	3	58	Fuel Valve	1
28	Dust-Proof Rubber	2	59	Clamp	1
29	Nylon Nut	2	60	Clamp	2
30	Washer, Plain	2	61	Breather Tube	1
31	Motor Assy	1			

GENERAL DIAGRAM

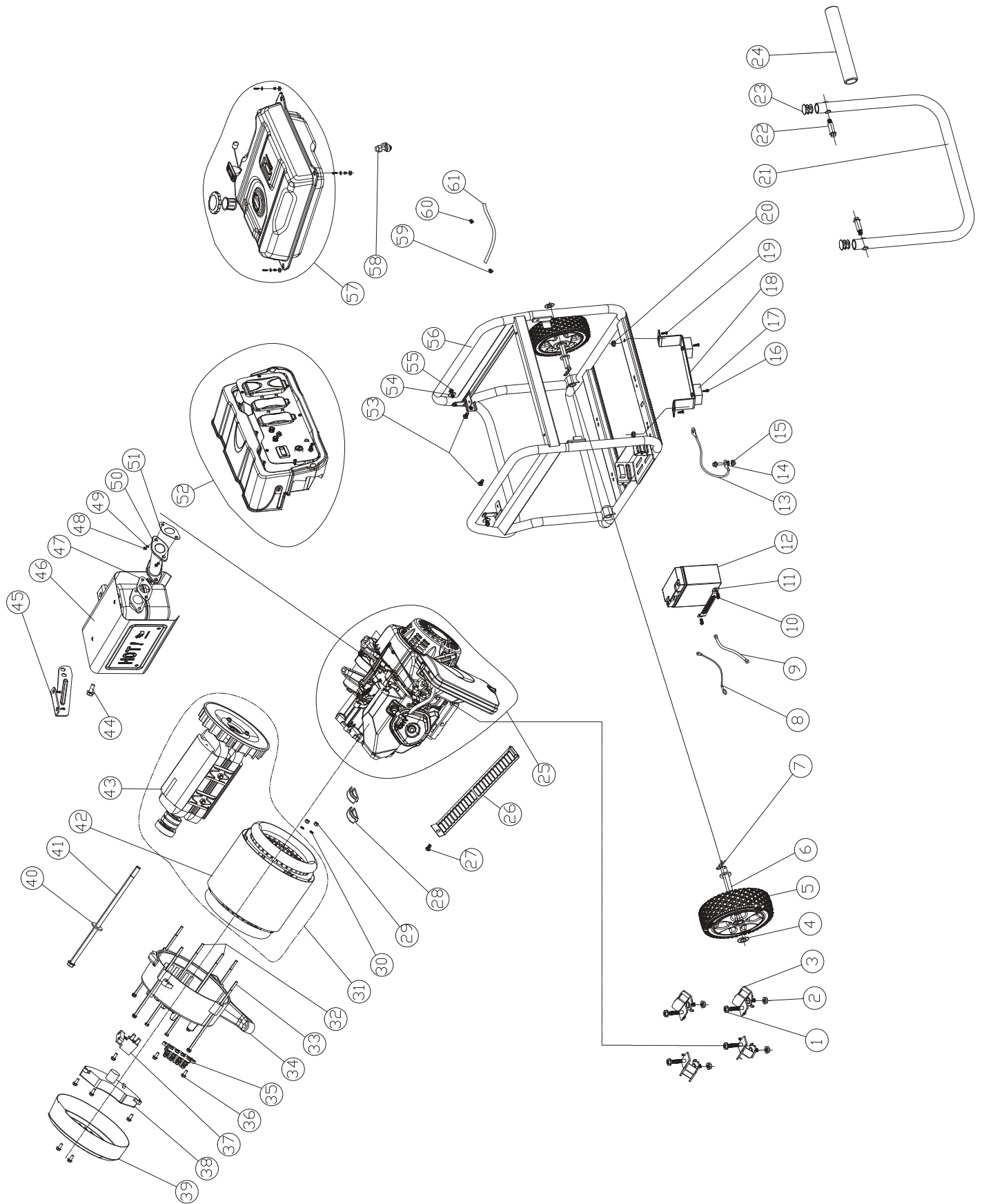

ENGINE PARTS LIST

Part	Discription	Qty	Part	Discription	Qty
1	Bolt	1	46	Bearing	2
2	Cylinder Head Cover Assy	1	47	Crankshaft Assy	1
3	Exhaust Pipe	1	48	Gasket, Crankcase Cover	1
4	Gasket, Cylinder Cap	1	49	Dowel Pin	2
5	Bolt,Flange	12	50	Crankcase Cover Assy	1
6	Air Deflector	1	51	Bolt,Flange	7
7	Regulating Nut, Rockshaft	2	52	Oil Seal	2
8	Rockshaft	2	53	Bearing	1
9	Rocker Arm	2	54	Dipstick	1
10	Bolt, Rockshaft	2	55	Bolt,Flange	2
11	Rotor, Exhaust Valve	1	56	Engine Oil Sensor	1
12	Spring Retainer, Exhaust Valve	1	57	Gestket, Rod	1
13	Spring Retainer, Intake Valve	1	58	Oil Seal	1
14	Valve Spring	2	59	Clip,Dowel Pin	1
15	Oil Shield	1	60	Regulating Gear Assy	1
16	Spring Retainer, Exhaust Valve	2	61	Washer, Plain	1
17	Plate, Push Rod Guide	1	62	Cam Shaft Assy	1
18	Cylinder Head Assy	1	63	Balance Shaft	1
19	Bolt,Stud,Intake	2	64	Rubber Seat	1
20	Gasket, Intake Valve	1	65	Clamp	1
21	Connector, Carburetor	1	66	Oil Alarming	1
22	Gasket, Carburetor	1	67	Adjusting Rod	1
23	Carburetor Assy	1	68	Regulating Control Assy	1
24	Gasket, Air Cleaner	1	69	Regulating Rocker Rod	1
25	Nut,Flange	3	70	Adjusting Spring	1
26	Clamp	2	71	Reset Spring	1
27	Fuel Tube	0.44	72	Adjusting Arm	1
28	Protective Sleeve	1	73	Starting Motor Assy	1
29	Bracket,Air Cleaner	1	74	Wire Cover	1
30	Air Cleaner Assy	1	75	Bolt,Flange	2
31	Bolt,Flange	4	76	Wire Pressing Plate	1
32	Bolt,Stud,Exhaust	2	77	Aluminum Gasket	2
33	Sparking Plug	1	78	Drain Bolt	2
34	Gasket, Cylinder Head	1	79	Charge Coil	1
35	Dowel Pin	2	80	Bolt,Flange	2
36	Push Rod	2	81	Ignition Coil Assy	1
37	Valve Lifter	2	82	Bolt,Flange	2
38	Intake Valve	1	83	Flywheel Assy	1
39	Exhaust Valve	1	84	Cooling Fan	1
40	Ring Set, Piston	1	85	Starting Cup	1
41	Piston	1	86	Nut,Flange	1
42	Clip, Piston Pin	2	87	Starter Assy, Recoil	1
43	Piston Pin	1	88	Clamp	1
44	Connector Rod Assy	1	89	Clamp	1
45	Crankcase Assy	1			

ENGINE DIAGRAM

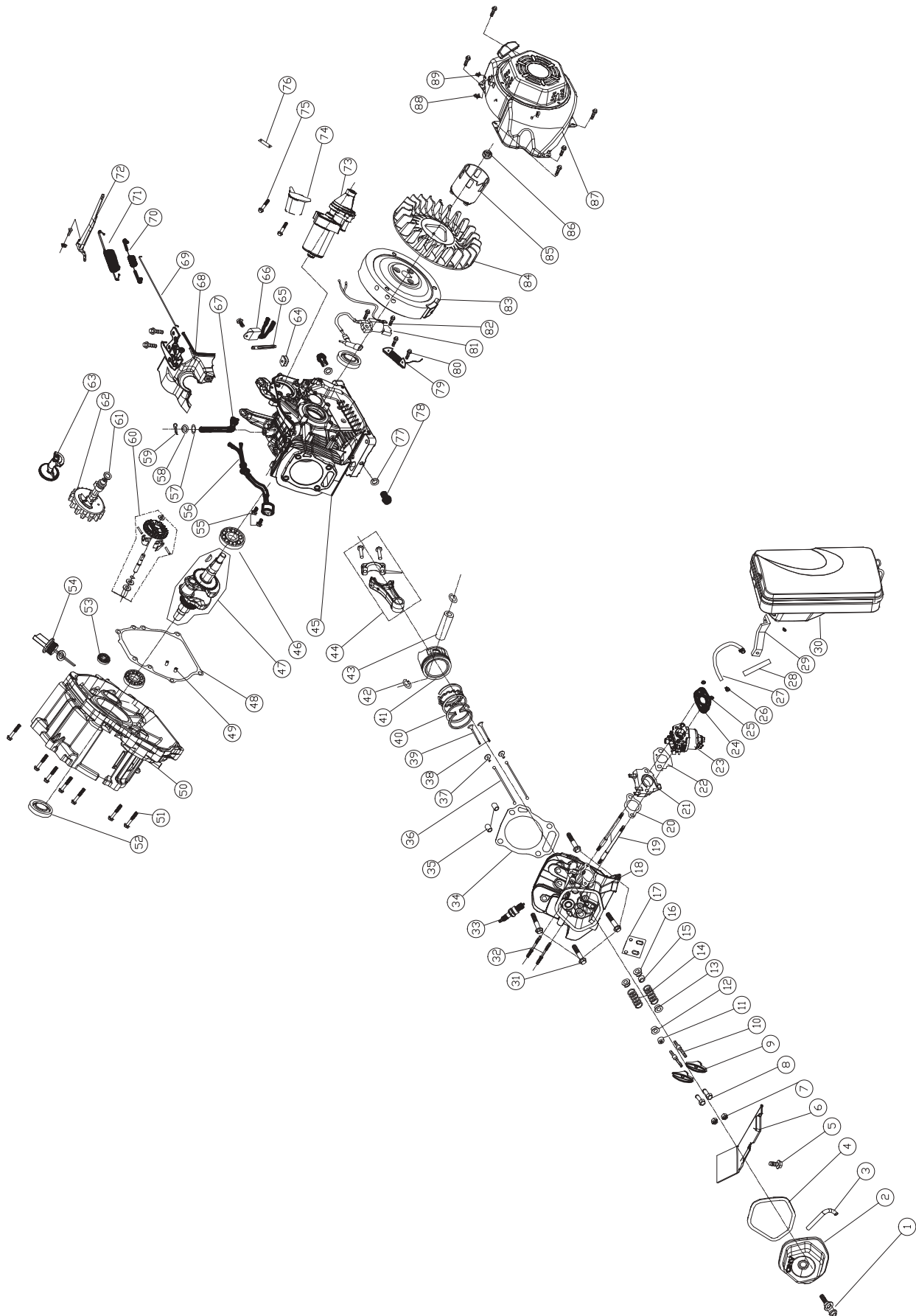

SECTION 12 — WARRANTIES

CALIFORNIA EMISSION CONTROL WARRANTY STATEMENT

YOUR WARRANTY RIGHTS AND OBLIGATIONS

The California Air Resources Board, the United States Environmental Protection Agency and A-iPOWER, are pleased to explain the emission control system warranty on your 2016 - 2017 model year small off-road engine/equipment. In the United States and California, new small off-road engine/equipment must be designed, built and equipped to meet the State's stringent anti smog standards. A-IPOWER must warrant the emission control system on your small off-road engine/equipment for the periods of time listed below provided there has been no abuse, neglect or improper maintenance of your small off-road engine/equipment.

Your emission control system may include parts such as the carburetor or fuel injection system, the ignition system, catalytic converter, fuel tanks, fuel lines, fuel caps, valves, canisters, filters, vapor hoses, clamps, connectors, belts, and other associated emission-related components. For engines less than or equal to 80 cc, only the fuel tank is subject to the evaporative emission control warranty requirements of this section (California only).

Where a warrantable condition exists, A-IPOWER will repair your small off-road engine/equipment at no cost to you including diagnosis, parts and labor.

MANUFACTURER'S WARRANTY COVERAGE:

This Emissions Control System is warranted for two years. If any emission-related part on your engine/equipment is defective, the part will be repaired or replaced by A-IPOWER.

OWNER'S WARRANTY RESPONSIBILITIES:

As the small off-road engine/equipment owner, you are responsible for the performance of the required maintenance listed in your owner's manual. A-IPOWER recommends that you retain all receipts covering maintenance on your small off-road engine/equipment, but A-IPOWER cannot deny warranty solely for the lack of receipts or for your failure to ensure the performance of all scheduled maintenance.

As the small off-road engine/equipment owner, you should however be aware that A-IPOWER may deny you warranty coverage if your small off-road engine/equipment or a part has failed due to abuse, neglect, improper maintenance or unapproved modifications.

You are responsible for presenting your small off-road engine/equipment to A-IPOWER distribution center as soon as a problem exists. The warranty repairs should be completed in a reasonable amount of time, not to exceed 30 days. If you have a question regarding your warranty coverage, you should contact Senci Power USA Inc at 1-855-888-3598 or support@a-ipower.com.

DEFECTS WARRANTY REQUIREMENTS:

(a) The warranty period begins on the date the engine/equipment is delivered to an ultimate purchaser.

(b) General Emissions Warranty Coverage. A-IPOWER warrants to the ultimate purchaser and each subsequent owner that the engine/equipment is:

- (1) Designed, built, and equipped so as to conform with all applicable regulations adopted by the Air Resources Board; and
- (2) Free from defects in materials and workmanship that causes the failure of a warranted part for a period of two years.

(c) The warranty on emissions-related parts will be interpreted as follows:

(1) Any warranted part that is not scheduled for replacement as required maintenance in the written instructions required by subsection (d) must be warranted for the warranty period defined in Subsection (b)(2). If any such part fails during the period of warranty coverage, it must be repaired or replaced by A-IPOWER according to Subsection (4) below. Any such part repaired or replaced under the warranty must be warranted for the remaining warranty period.

(2) Any warranted part that is scheduled only for regular inspection in the written instructions required by subsection (d) must be warranted for the warranty period defined in Subsection (b)(2). A statement in such written instructions to the effect of "repair or replace as necessary" will not reduce the period of warranty coverage. Any such part repaired or replaced under

warranty must be warranted for the remaining warranty period.

(3) Any warranted part that is scheduled for replacement as required maintenance in the written instructions required by subsection (d) must be warranted for the period of time prior to the first scheduled replacement point for that part. If the part fails prior to the first scheduled replacement, the part must be repaired or replaced by A-IPOWER according to Subsection (4) below. Any such part repaired or replaced under warranty must be warranted for the remainder of the period prior to the first scheduled replacement point for the part.

(4) Repair or replacement of any warranted part under the warranty must be performed at no charge to the owner at a warranty station.

(5) Notwithstanding the provisions of Subsection (4) above, warranty services or repairs must be provided at all A-IPOWER distribution centers that are franchised to service the subject engine/equipment.

(6) The owner must not be charged for diagnostic labor that leads to the determination that a warranted part is in fact defective, provided that such diagnostic work is performed at a warranty station.

(7) A-IPOWER is liable for damages to other engine/equipment components proximately caused by a failure under warranty of any warranted part.

(8) Throughout the emissions warranty period defined in Subsection (b)(2), A-IPOWER must maintain a supply of warranted parts sufficient to meet the expected demand for such parts.

(9) Any replacement part may be used in the performance of any warranty

maintenance or repairs and must be provided without charge to the owner. Such use will not reduce the warranty obligations of A-IPOWER.

(10) Add-on or modified parts that are not exempted by the Air Resources Board may not be used. The use of any non-exempted add-on or modified parts will be grounds for disallowing a warranty claim. A-IPOWER will not be liable to warrant failures of warranted parts caused by the use of a non-exempted add-on or modified part.

(11) A-IPOWER issuing the warranty shall provide any documents that describe that manufacturer's warranty procedures or policies within five working days of request by the Air Resources Board.

(d) Emission Warranty Parts List for exhaust (for all displacements).

(1) Fuel Metering System

(i) Carburetor and internal parts (and/or pressure regulator or fuel injection system).

(ii) Air/fuel ratio feedback and control system.

(iii) Cold start enrichment system.

(2) Air Induction System

(i) Controlled hot air intake system.

(ii) Intake manifold.

(iii) Air filter.

(3) Ignition System

(i) Spark Plugs.

(ii) Magneto or electronic ignition system.

(iii) Spark advance/retard system.

(4) Exhaust Gas Recirculation (EGR) System

(i) EGR valve body, and carburetor spacer if applicable.

(ii) EGR rate feedback and control system.

(5) Air Injection System

(i) Air pump or pulse valve.

(ii) Valves affecting distribution of flow.

(iii) Distribution manifold.

(6) Catalyst or Thermal Reactor System

(i) Catalytic converter.

(ii) Thermal reactor.

(iii) Exhaust manifold.

(7) Particulate Controls

(i) Traps, filters, precipitators, and any other device used to capture particulate emissions.

(8) Miscellaneous Items Used in Above Systems

(i) Electronic controls.

(ii) Vacuum, temperature, and time sensitive valves and switches.

(e) Emission Warranty Parts List for Evap less than or equal to 80cc.

(i) Fuel Tank.

(f) Emission Warranty Parts List for Evap greater than 80cc.

(1) Fuel Metering System

(i) Fuel Tank.

(2) Miscellaneous Items Used in Above Systems

(i) Fuel caps, valves, canisters, filters, vapor, hoses, clamps, connectors, belts, and assemblies.

A-iPower will furnish with each new engine/equipment written instructions for the maintenance and use of the engine/equipment by the owner.

A-iPower's only liability shall be the repair or replacement of part(s) as stated above in no event shall A-iPower be liable for any incidental or consequential damages.

A-iPower Limited Warranty Policy

Thank You For Choosing A-iPower Generator!

Our Warranty

A-iPower will, at its position, free of charge, repair or replace any part(s) which, upon examination, inspection and testing by A-iPower or an A-iPower authorized warranty service dealer that is defective in material or workmanship or both. Transportation charges on product submitted for repair or replacement under this warranty must be borne by purchaser. Retain your proof-of-purchase receipt. If you do not provide proof of the initial purchase date, the manufacturer's shipping date of the product will be used to determine the warranty period starting. Customer is responsible for taking the unit to & from the "pre-approved" warranty center if there is an issue with the unit that needs mechanical work.

Warranty Term

Any new A-iPower generator purchased for non-commercial use from an authorized A-iPower generator dealer in the continental North America will be warranted against defects in material or workmanship for a period of one years, from date of purchase, subject to exclusions noted herein. The warranty period begins on the date of purchase by the first retail end-user, and continues for the period of warranty time. A-iPower customer service will keep on supplying spare parts per request after warranty period with cost charge. "Comsumer Use" means residential household using by a retail consumer. "Commercial Use" means all other uses, including used for commercial, industrial or business or rental purposes. Once equipment has experienced commercial use, it shall thereafter be considered as commercial use for purposes of this warranty.

Warranty Exclusions

Most warranty repairs are handled routinely, but sometimes requests for warranty service may not be appropriate. This warranty will not cover the following:

REGULAR WEARING: Outdoor Power Equipment, as with all mechanical devices, need periodic parts(s) service and replacement to perform as designed. This warranty will not cover repair when normal use has exhausted the lifetime of any part. **INSTALLTION AND MAINTENANCE:** This warranty does not cover the generator or its parts what have been subjected to improper or unauthorized accident, over-speeding, improper maintenance, repair or storage so as, in our judgment, to adversely affect its performance and reliability. This warranty also does not cover regular maintenance and parts such as air filters, adjustments, fuel system cleaning and obstruction (due to chemical, dirt, carbon lime, and so forth).

OTHER: This warranty excludes wearing parts such as oil seal, etc. or malfunction resulting from accidents, abuse, modifications, alterations, or improper servicing or freezing or chemical deterioration; damaged related to rodent and/or insect infestation. This warranty excludes used, reconditioned and demonstration equipment, equipment used for prime power in place of utility power, equipment used in life support applications, and failures due to acts of God and other force majeure events beyond the manufacturers control, such as collision, theft, vandalism, riot or wars, nuclear holocaust, fire, freezing, lightning, earth-quake, windstorm, hail, volcanic eruption, water or flood, tornado or hurricane.

How To Obtain Warranty Service

Please call our customer service number 1-855-888-3598, or email to support@a-ipower.com to contact our support team at first in case of a service needed. Please prepare and provide the model number, serial number and the proof of purchase while contacting us or mail a request to:

A-iPower Corp.

1477 E. Cedar St. STE B, Ontario, CA 91761, U.S.A.

A-iPOWER WARRANTY REGISTRATION FORM

Register your product by mailing this form to support@a-ipower.com or register online at www.a-ipower.com.

Registering your product is important, it provides protection

- 1) You have record of product purchased
- 2) Customer Service can Better serve you for Warranty related issues
- 3) We can contact you in the unlikely event should notification is necessary
- 4) Always keep copy of your original receipt

Primary Information	Generator Information
Name: _____ Phone: _____ E-mail: _____ Address: _____ City, State, Zip code: _____ Date of purchase: _____ Where: _____	Serial # _____ _____ Model # _____ _____ _____
	The serial No. can be found on the engine. PLEASE NOTE: Your generator cannot be registered without model & serial numbers.

1. THE PRODUCT WAS PURCHASED FOR:

- | | |
|---|---|
| <ul style="list-style-type: none"> A. <input type="checkbox"/> Home back-up B. <input type="checkbox"/> Businessback-up C. <input type="checkbox"/> Camping D. <input type="checkbox"/> Tailgating E. <input type="checkbox"/> Rental F. <input type="checkbox"/> Farming/Agriculture | <ul style="list-style-type: none"> G. <input type="checkbox"/> Jobsite/construction H. <input type="checkbox"/> Outdoor activities (Hunting) I. <input type="checkbox"/> Special Events J. <input type="checkbox"/> Battery Charging K. <input type="checkbox"/> Other _____ |
|---|---|

2. THIS PRODUCT IS A: (select one)

- | | |
|---|---|
| A. <input type="checkbox"/> First Time Purchase | B. <input type="checkbox"/> Replacement |
|---|---|

3. HOW DID YOU FIRST LEARN OF THIS PRODUCT: (select one)

- | | |
|--|--|
| <ul style="list-style-type: none"> A. <input type="checkbox"/> Magazine Ad B. <input type="checkbox"/> Newspaper C. <input type="checkbox"/> Radio D. <input type="checkbox"/> TV E. <input type="checkbox"/> Store Display F. <input type="checkbox"/> Contractor | <ul style="list-style-type: none"> G. <input type="checkbox"/> Trade Show H. <input type="checkbox"/> Direct Mail I. <input type="checkbox"/> From Friend/Relative/Neighbor J. <input type="checkbox"/> Catalog K. <input type="checkbox"/> Internet L. <input type="checkbox"/> Other _____ |
|--|--|

4. PLEASE RATE YOUR SATISFACTION LEVEL WITH THE FOLLOWING:

	Completely Satisfied 5	4	3	2	Not at all Satisfied 1
Product Value for Price Paid	<input type="checkbox"/>	<input type="checkbox"/>	<input type="checkbox"/>	<input type="checkbox"/>	<input type="checkbox"/>
Performance	<input type="checkbox"/>	<input type="checkbox"/>	<input type="checkbox"/>	<input type="checkbox"/>	<input type="checkbox"/>
Features	<input type="checkbox"/>	<input type="checkbox"/>	<input type="checkbox"/>	<input type="checkbox"/>	<input type="checkbox"/>
Product Appearance	<input type="checkbox"/>	<input type="checkbox"/>	<input type="checkbox"/>	<input type="checkbox"/>	<input type="checkbox"/>
Warranty	<input type="checkbox"/>	<input type="checkbox"/>	<input type="checkbox"/>	<input type="checkbox"/>	<input type="checkbox"/>
Ease of Maintenance	<input type="checkbox"/>	<input type="checkbox"/>	<input type="checkbox"/>	<input type="checkbox"/>	<input type="checkbox"/>
Noise Level	<input type="checkbox"/>	<input type="checkbox"/>	<input type="checkbox"/>	<input type="checkbox"/>	<input type="checkbox"/>

5. HOW LIKELY ARE YOU TO RECOMMEND A-iPOWER TO FAMILY OR FRIENDS?

	Extremely Likely 5	4	3	2	Not likely at all 1
	<input type="checkbox"/>	<input type="checkbox"/>	<input type="checkbox"/>	<input type="checkbox"/>	<input type="checkbox"/>

Privacy Statement: A-ipower is committed to respecting your privacy and to complying with the regulations regarding the protection of personal data.

The survey data we collect is for the purposes of marketing or product support and demographic information about the entire audience registering their products.



1477 E. Cedar Street # B,
Ontario, CA 91761, U.S.A.
Phone: 855-888-3598, 626-225-8930
support@a-ipower.com
[www. a-ipower.com](http://www.a-ipower.com)