



OPERATOR'S MANUAL FOR 4 in. ANGLE GRINDER 11,000 RPM

Model No. EATAG40S1P



Operator Instructions

Includes – Please Read and Comply, Warnings , Product Configuration and Specifications Table, Parts Page, Parts List, Work Stations, Putting the Tool Into Service, Compressor Layout and Safety Information.

Important

Read these instructions carefully before installing, operating, servicing or repairing this tool. Keep these instructions in a safe accessible location.

Required Personal Safety Equipment



Safety Glasses



Breathing Masks



Safety Gloves



Ear Protection

**Recommended Airline
Size - Minimum**

10 mm 3/8 in

**Recommended Maximum
Hose Length**

8 meters 25 feet

Air Pressure

Maximum Working Pressure	6.2 bar	90 psig
Recommended Minimum	NA	NA

Please Read and Comply with

- 1) General Industry Safety & Health Regulations, Part 1910, OSHA 2206, available from: Superintendent of Documents; Government Printing Office; Washington DC 20402
- 2) Safety Code for Portable Air Tools, ANSI B186.1 available from: American National Standards Institute, Inc.; 1430 Broadway; New York, New York 10018
- 3) State and Local Regulations.

Warning

Always wear eye protection when operating or performing maintenance on this tool.
Always turn off the air supply and disconnect the air supply hose before installing, removing or adjusting any accessory on this tool, or before performing any maintenance on this tool.
Improper operation or maintenance of this product could result in serious injury and property damage.
Read and understand all warnings and operation instructions before using this equipment.

Parts Page

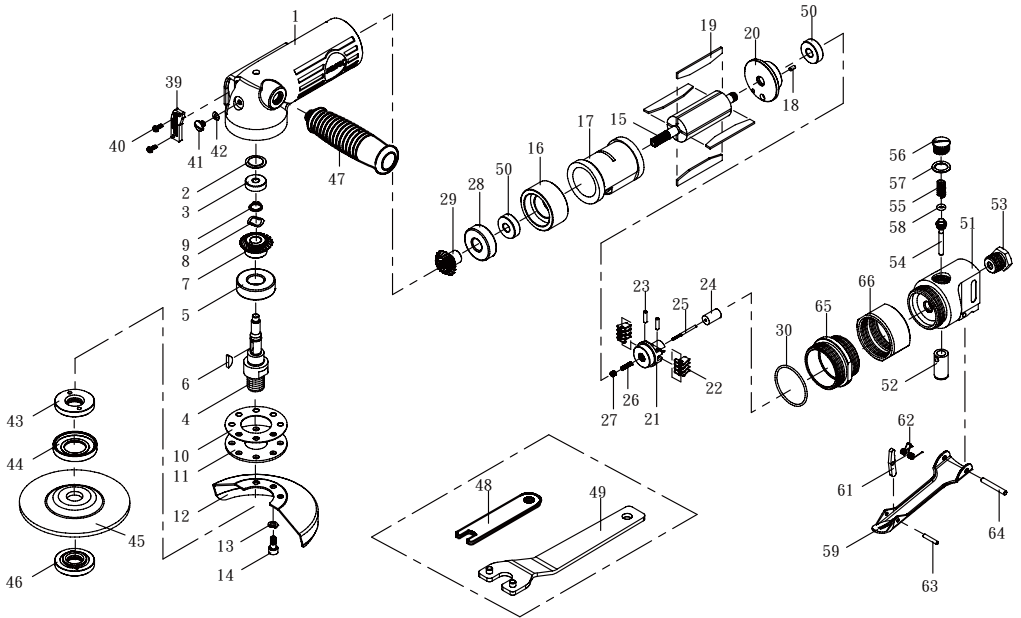

Parts List

Item No.	Part No.	Description	Qty.
1	DG-40001#LW-EMAX	MOTOR HOUSING	1
2	DG-40002	SEAL PLATE	1
3	BB-06262	BALL BEARING	1
4	DG-40004	ARBOR	1
5	BB-62022	BALL BEARING	1
6	XPA0041	WOODRUFF KEY	1
7	DG-40007	BEVEL GEAR	1
8	WW-0010	WAVE WASHER	1
9	STW-010	EXTERNAL STOP RING	1
10	DG-40010	GASKET	1
11	DG-40011	RETAINER	1
12	DG-40012	CENTER WHEEL GUARD	1
13	SW2-050A	SPRING WASHER	5
14	B2-0512A	HEX SOCKET HEAD CAP BOLT	5
15	DG-40015	ROTOR	1
16	DG-40016	FRONT END PLATE	1
17	VP-70017	CYLINDER	1
18	SP-30060	SPRING PIN	1
19	VP-70014	ROTOR BLADE	4
20	VP-70013	REAR END PLATE	1
21	DG-40021	GOVERNOR	1
22	DG-40022	PENDULUM	8
23	SP-30120	SPRING PIN	2
24	DG-40024	PLUNGER	1
25	DG-40025	ADJUST SCREW	1
26	DG-40026	SPRING	1
27	DG-40027	ADJUST NUT	1
28	BB-62012	BALL BEARING	1
29	DG-40029	BEVEL PINION	1
30	DG-40030	O-RING	1
39	DG-40039	EXHAUST DEFLECTOR	1
40	T2-3008B	TAPPING SCREW	2
41	PG-38043	PLUG	1
42	ORP-0040	O-RING	1
43	AG-30052	FLANGE	1
44	AG-30053	FLANGE RUBBER SHIELD	1
45	AG-40059	GRINDING WHEEL	OPT
46	AG-30054	FLANGE NUT	1
47	AP-70C47	HANDLE	1
48	DG-40048	WRENCH(A)	1
41	AG-30058	WRENCH(B)	1
50	BB-06082	BALL BEARING	2
51	DG-40051#LW	THROTTLE VALVE HOUSING	1
52	DG-40052	BUSHING	1
53	AR-38001	AIR INLET BUSHING	1
54	DG-40054	VALVE STEM	1
55	DG-40055	VALVE SPRING	1
56	DG-40056	THROTTLE LEVER PLUG	1
57	ORP-0120	O-RING	1
58	DG-40058	O-RING	1
59	DG-40059	THROTTLE LEVER	1
61	DG-40061	THROTTLE LEVER LOCK	1
62	DG-40062	TORSION SPRING	1
63	SP-30160	SPRING PIN	1
64	SP-40300	SPRING PIN	1
65	DG-40065	LOCK RING	1
66	DG-40066	COUPLING NUT	1

Product Configuration/Specifications

Model Number	Free Speed (rpm)	Spindle Thread	Product Net Weight Pound (kg)	Height in. (mm)	Length in. (mm)	Air Consumption scfm (LPM)
EATAG40S1P	11,000	3/8"x24	4.00 (1.82)	3.78 (96)	9.00 (229)	33 (934)

Specifications subject to change without prior notice.

The actual exposure values and amount of risk or harm experienced to an individual is unique to each situation and depends upon the surrounding environment, the way in which the individual works, the particular material being worked, work station design as well as upon the exposure time and the physical condition of the user. EMAX™ cannot be held responsible for the consequences of using declared values instead of actual exposure values for any individual risk assessment.

Further occupational health and safety information can be obtained from the following websites: <https://osha.europa.eu/en> (Europe); <http://www.osha.gov> (USA)

Work Stations

The tool is intended to be operated as a hand held tool. It is always recommended that the tool be used when standing on a solid floor. It can be in any position but before any such use, the operator must be in a secure position having a firm grip and footing and be aware that the tool can develop a torque reaction. See the section "Safety Information".

Putting the Tool into Service

Use a clean lubricated air supply that will give a measured air pressure at the tool of 90 psig (6.2 bar) when the tool is running with the lever fully depressed. It is recommended to use an approved 3/8 in. (10 mm) x 25 ft (8 m) maximum length airline. It is recommended that the tool be connected to the air supply as shown in Figure 1.

Do not connect the tool to the airline system without incorporating an easy to reach and operate air shut off valve. The air supply should be lubricated. It is strongly recommended that an air filter, regulator and lubricator (FRL) be used as shown in Figure 1 as this will supply clean, lubricated air at the correct pressure to the tool. Details of such equipment can be obtained from your supplier. If such equipment is not used then the tool should be manually lubricated

To manually lubricate the tool, disconnect the airline and put 2 to 3 drops of suitable pneumatic Airbase synthetic air tool oil must be used for lifetime warranty. Part# OIL012 into the hose end (inlet) of the machine. Reconnect tool to the air supply and run tool slowly for a few seconds to allow air to circulate the oil. If the tool is used frequently, lubricate it on a daily basis or lubricate it if the tool starts to slow or lose power.

It is recommended that the air pressure at the tool be 90 PSI (6.2 Bar) while the tool is running so the maximum RPM is not exceeded. The tool can be ran at lower pressures but should never be ran higher than 90 PSI (6.2 Bar). If ran at lower pressure the performance of the tool is reduced.

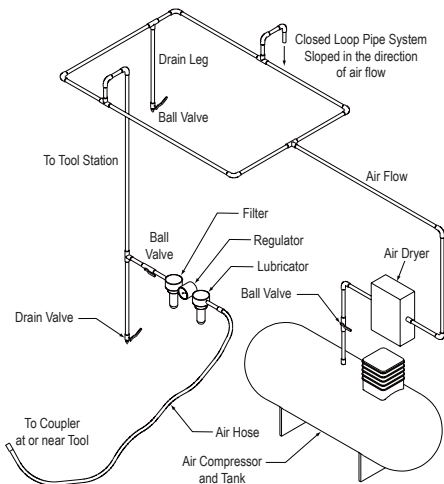

Figure 1

Safety Information

- 1) Read all instructions before using this tool. All operators must be fully trained in its use and aware of these safety requirements. All service and repair must be carried out by trained personnel.
- 2) Never direct air at yourself or anyone else.
- 3) Install air fitting into inlet bushing of tool.
- 4) Always remove the air supply to the tool before fitting, adjusting or removing the abrasive/accessory.
- 5) Always wear required safety equipment when using this tool.
- 6) When operating always place the tool on the work then start the tool. Always remove the tool from the work before stopping. This will prevent gouging of the work due to excess speed of the abrasive/accessory.
- 7) Always adopt a firm footing and/or position and be aware of torque reaction developed by the tool.
- 8) Use only correct spare parts.
- 9) Always ensure that the workpiece is firmly fixed to prevent its movement.
- 10) Check hose and fittings regularly for wear. Do not carry the tool by its hose; always be careful to prevent the tool from being started when carrying the tool with the air supply connected.
- 11) Dust can be highly combustible. Keep working area clean.
- 12) Dust from some work processes can cause cancer, birth defects or other respiratory diseases. Risk assessment of these hazards and implementation of appropriate controls is essential.
- 13) Direct the exhaust so as to minimized disturbance of dust in a dust filled environment
- 14) Do not operate the tool in explosive atmospheres, such as in the presence of flammable liquids, gases, or dust. The abrasives are able to create sparks when working material, resulting in the ignition of the flammable dust or fumes.
- 15) Do not exceed maximum recommended air pressure. Use safety equipment as recommended.
- 16) The tool is not electrically insulated. Do not use where there is a possibility of coming into contact with live electricity, gas pipes, water pipes, etc. Check the area of operation before operation.
- 17) Take care to avoid entanglement with the moving parts of the tool with clothing, ties, hair, cleaning rags, etc. If entangled, it will cause the body to be pulled towards the work and moving parts of the machine and can be very dangerous.
- 18) Keep hands away from rotating or accessories, spindles or other moving parts during use.
- 19) If the tool appears to malfunction, remove from use immediately and arrange for service and repair.
- 20) Do not allow the tool to free speed without taking precautions to protect any persons or objects from the loss of the abrasive/accessory.
- 21) Do not allow tool to free run for an extended period of time as this will shorten its life.

Year Standard Warranty

Our Standard warranty covers defects or failures in workmanship or materials in our air tools 2 years from the date of purchase. EMAX will repair or replace; at their discretion any defective part or unit which proves to be defective. This warranty does not cover incidental/consequential damages and failures due to misuse, abuse or normal wear and tear.

Any modification, repair or repair attempts not authorized are not covered under this warranty.

Shipping for warranty claims are included in this warranty for the first 90 days.

***Limited Extended Lifetime Warranty**

Our LIMITED EXTENDED LIFETIME WARRANTY is our no questions asked warranty. It covers defects or failures in workmanship or materials in our air tools for the life of the tool. EMAX will repair or replace; at their discretion any defective part or unit which proves to be defective. This warranty does not cover incidental/consequential damages and failures due to misuse, abuse or normal wear and tear (sanding pads and discs, chisels, tips, needs, nozzles, etc).

ANY MODIFICATION, REPAIR OR REPAIR ATTEMPTS NOT AUTHORIZED ARE NOT COVERED UNDER THIS WARRANTY.

SHIPPING FOR WARRANTY CLAIMS ARE INCLUDED IN THIS WARRANTY FOR THE FIRST 90 DAYS.

3 SIMPLE STEPS TO QUALIFY FOR YOUR EXTENDED LIFETIME AIR TOOL WARRANTY:

- 1. Register your air tool purchase at www.emaxwarranty.com , be sure to have your original receipt of purchase in hand for important information needed in your registry.**
 - 2. Write a review on the site where you purchased your air tool**
 - 3. Send us a screen shot or photograph of your review to NGRUBE@EMAXCOMPRESSOR.COM to complete your extended lifetime warranty registration.**
- For warranty claims or more information call EMAX directly at: 1-866-294-4153

EMAX PHONE: 1-866-294-4153



EMAX
SILENT AIR TECHNOLOGY

The logo features the word "EMAX" in a large, bold, white, stylized font with a black outline, set against a dark blue background. Below it, the words "SILENT AIR TECHNOLOGY" are written in a smaller, bold, yellow font.