

We thank you for choosing an Australian Made Shed. For further assistance please visit our detailed instructional video library at <http://www.absco.com.au/videos.php>

At ABSCO Industries we are always looking to be number ONE, so please let us know what you think of our instructions. Feedback makes us better.
feedback@absco.com.au.



GENERAL INSTRUCTIONS

Before commencing any assembly, read through these instructions in detail to gain a thorough understanding of assembly methods and associated details.

Unpack the carton and carefully identify and check off all the parts against the parts described and illustrated on pages three and four.

SITE PREPARATION

The site for the shed must be level.

It is recommended that the shed be set on a 4" concrete slab and anchored down appropriately (refer last page for details).

Anchor sets are not supplied as standard items with this product.

TOOLS REQUIRED



Normal 1/8", 11/64"



OPTIONAL



Normal 25/64"
Masonry 25/64"

A NOTE ON SAFETY







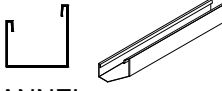

Some parts may have sharp edges. It is advisable to wear gloves when handling these items and safety glasses if drilling holes. Sensible shoes are highly recommended.

Do not erect your shed in windy conditions, ensure that the shed is securely anchored to a solid foundation immediately after construction is completed.

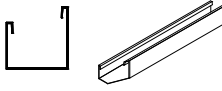
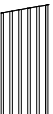
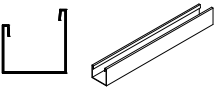
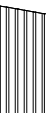

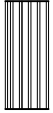

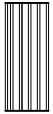
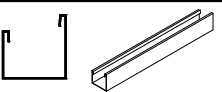

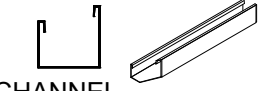
It is highly recommended to erect the shed with two or more people.

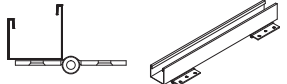
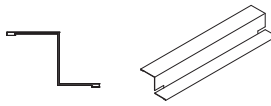
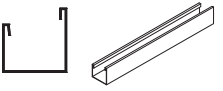
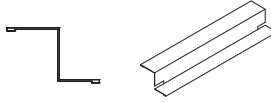
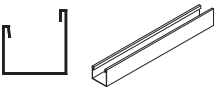
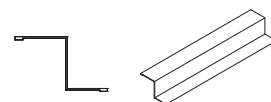
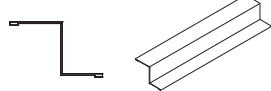
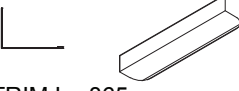

COMPONENTS PACKING LIST - CHECK OFF ALL COMPONENTS

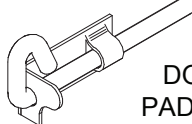
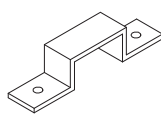
QTY	COMPONENT DESCRIPTION	PART No.	CHECK	QTY	COMPONENT DESCRIPTION	PART No.	CHECK
2	 STEEL SHEET 1915mm (75.39") X 773mm (30.43")	43B		1	 CHANNEL L = 2253mm (88.70")	54C	
1	 STEEL SHEET 1915mm (75.39") X 773mm (30.43")	43C		1	 CHANNEL L = 2253mm (88.70")	54B	
1	 STEEL SHEET 1915mm (75.39") X 773mm (30.43")	X4L		1	 CHANNEL L = 2253mm (88.70")	81D	
1	 STEEL SHEET 1915mm (75.39") X 773mm (30.43")	X4R		2	 CHANNEL L = 786mm (30.95")	61B	
3	 STEEL SHEET 865mm (34.05") X 773mm (30.43")	43D		2	 CHANNEL L = 773mm (30.43")	81J	
2	 STEEL SHEET 1785mm (70.27") X 731mm (28.78")	32A		2	 CHANNEL L = 2253mm (88.70")	81C	
1	 STEEL SHEET 1725mm (67.91") (67.91") X 773mm (30.43")	B		1	 CHANNEL L = 788mm (31.03")	79B	
1	 CHANNEL L = 2253mm (88.70")	54A					

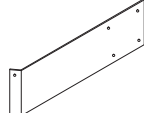

COMPONENTS PACKING LIST - (CONT.) CHECK OFF ALL COMPONENTS

QTY	COMPONENT DESCRIPTION	PART No.	CHECK	QTY	COMPONENT DESCRIPTION	PART No.	CHECK
1	 CHANNEL WITH HINGES L = 1725mm (67.91")	58A		1	 JAMB L= 1785mm (70.27")	89B	
1	 CHANNEL L = 1725mm (67.91")	58B		1	 JAMB L= 788mm (31.03")	90B	
2	 CHANNEL L = 773mm (30.43")	58C		2	 JAMB L= 1120mm (44.09")	91A	
1	 JAMB L= 1785mm (70.27")	89A		2	 LIP TRIM L= 865mm (34.05")	88B	
CONTENTS OF FITTINGS PACKET							
220	 SELF TAPPING SCREWS			1	 DOOR PADBOLT	22A	
1	DOOR PADBOLT HASP 			6	 3mm (0.12") POP RIVETS SECURE HINGES TO DOOR		
6	 4mm (0.16") CSK SCREW & NUT SECURE HINGES TO DOOR (ALTERNATE METHOD)			1	 RIVET GUN		
1	ASSEMBLY INSTRUCTIONS			1	 DOOR STRAP L: 165mm (6.50")	12A	

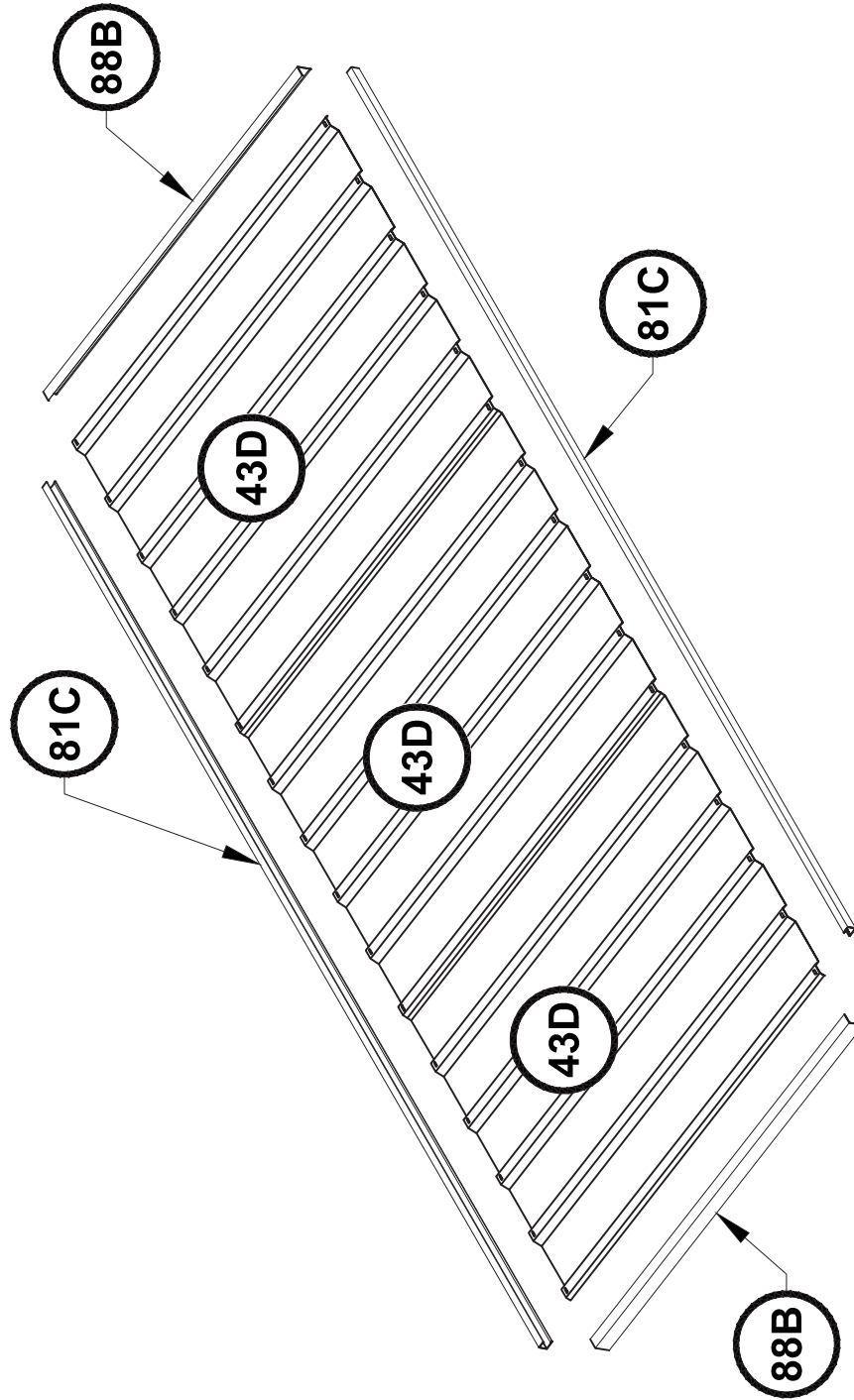

VIEW OF ROOF COMPONENTS

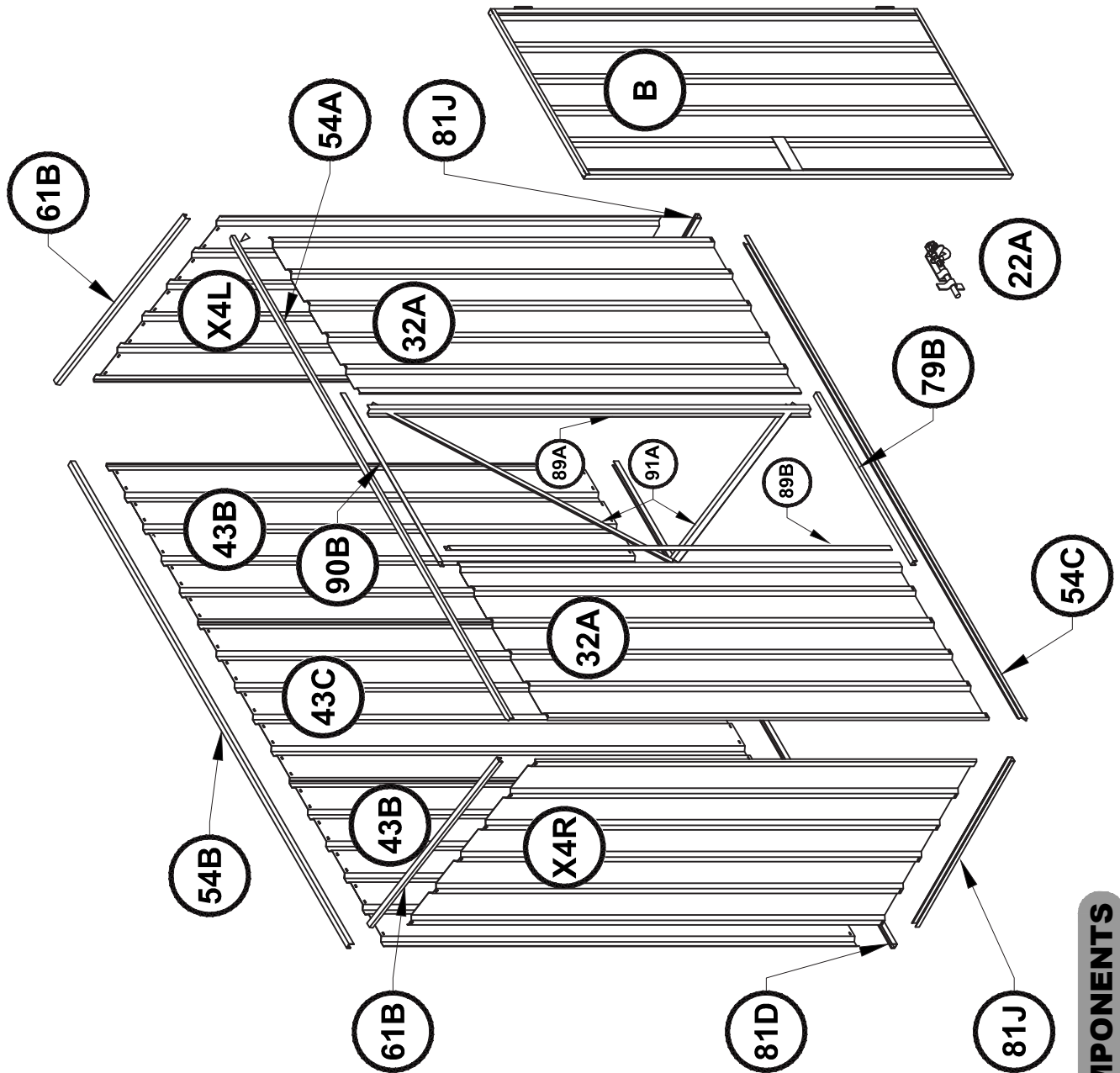



VIEW OF WALL COMPONENTS



ABSCO ASSEMBLY INTRODUCTION

The snap-tite assembly system locks most perimeter channels to all roof and wall sheets without the need for tools and fasteners.

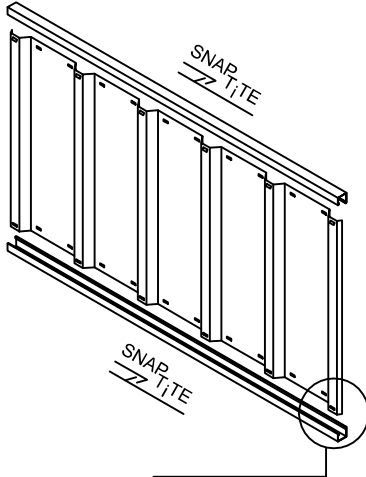

To pre-assemble the four wall panels and two roof panels, the perimeter channels are secured to the top and bottom of each panel using the snap-tite system, as detailed on the following pages wherever you see the symbol.

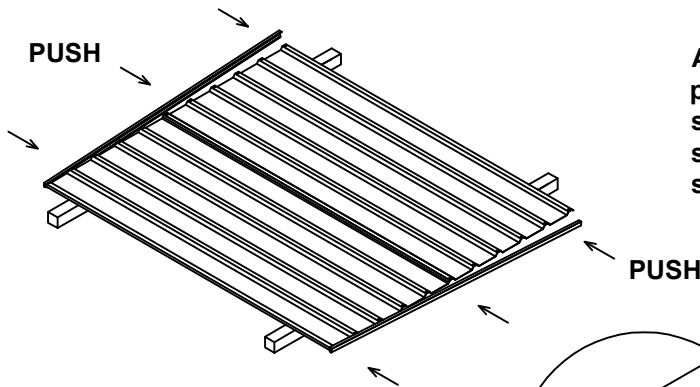
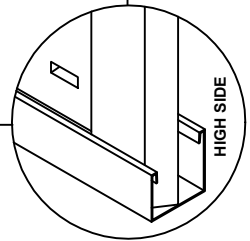
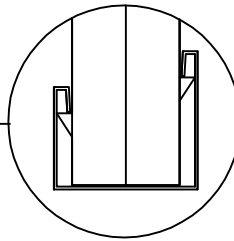
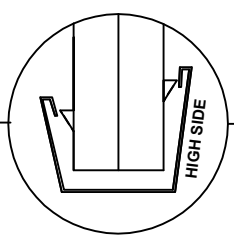
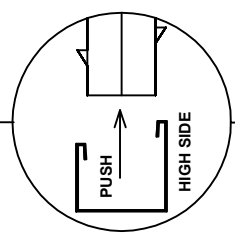
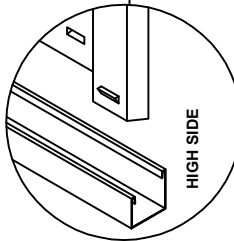
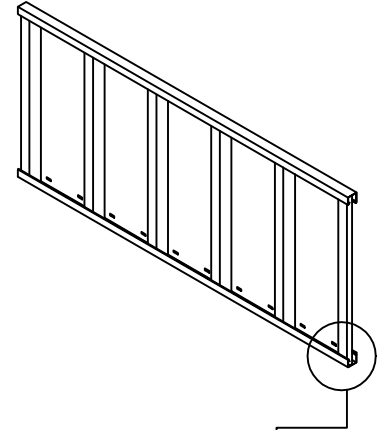

After joining sheets together, position channel over one end of the sheets, gently tapping it over the snap-tite lugs, working along the sheets to the other end.

Position sheets on timbers, trestles or partly over edge of concrete slab.

Each perimeter channel must finish flush with the edges of the sheets. The snap-tite system allows adjustment for this process by simply tapping the channel along the sheets until each end is neatly flush.

FASTENING SYMBOLS



Join components together with one screw at this location only, as some channel sections have extra holes that are not required for this model of garden shed

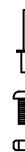

3mm (0.12") POP RIVETS

4mm (0.16") NUT & BOLT SET



Do not join components together at this location yet, as the screw may obstruct further assembly of other components



DOOR PANEL ASSEMBLY

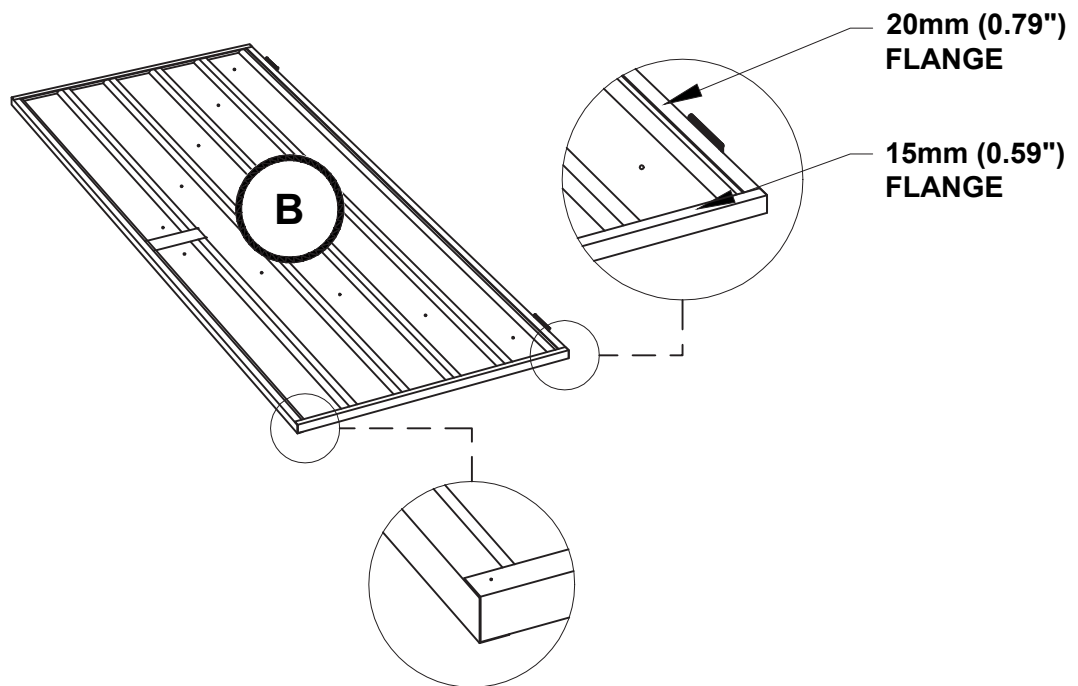
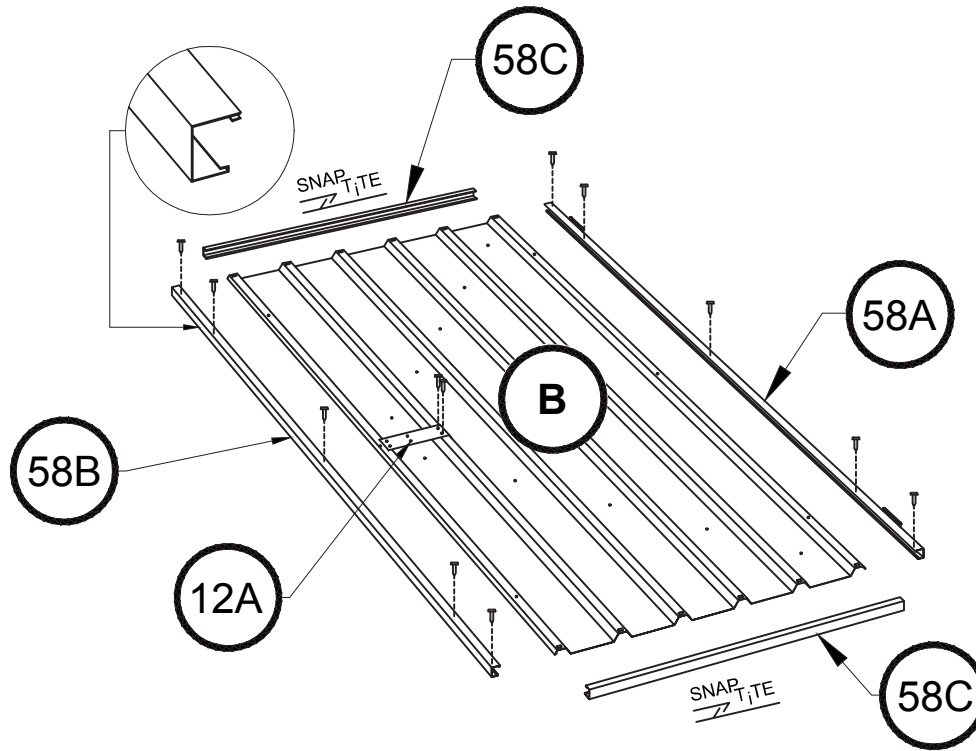



REAR PANEL ASSEMBLY

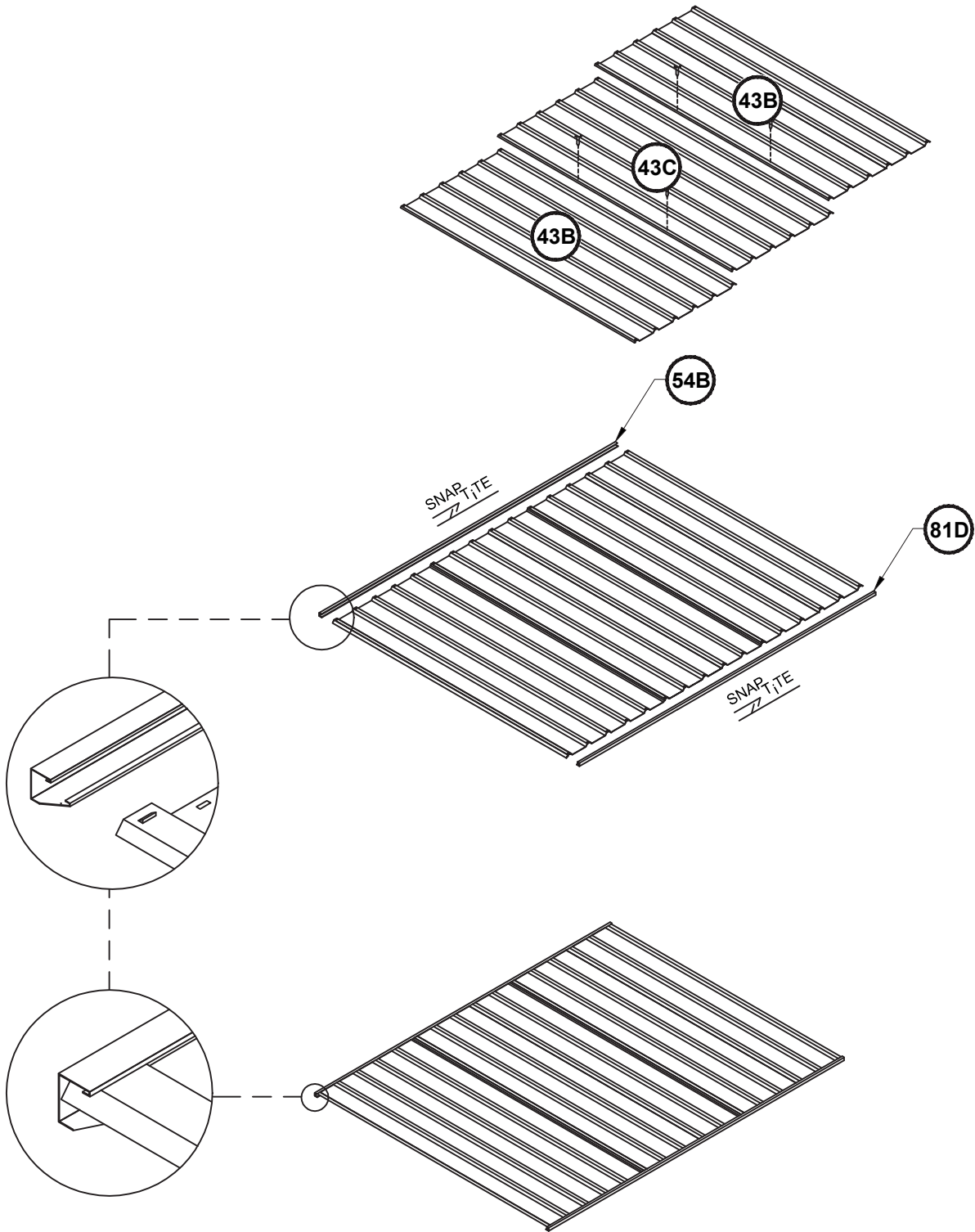



SIDE PANEL ASSEMBLY

(TWO REQUIRED)

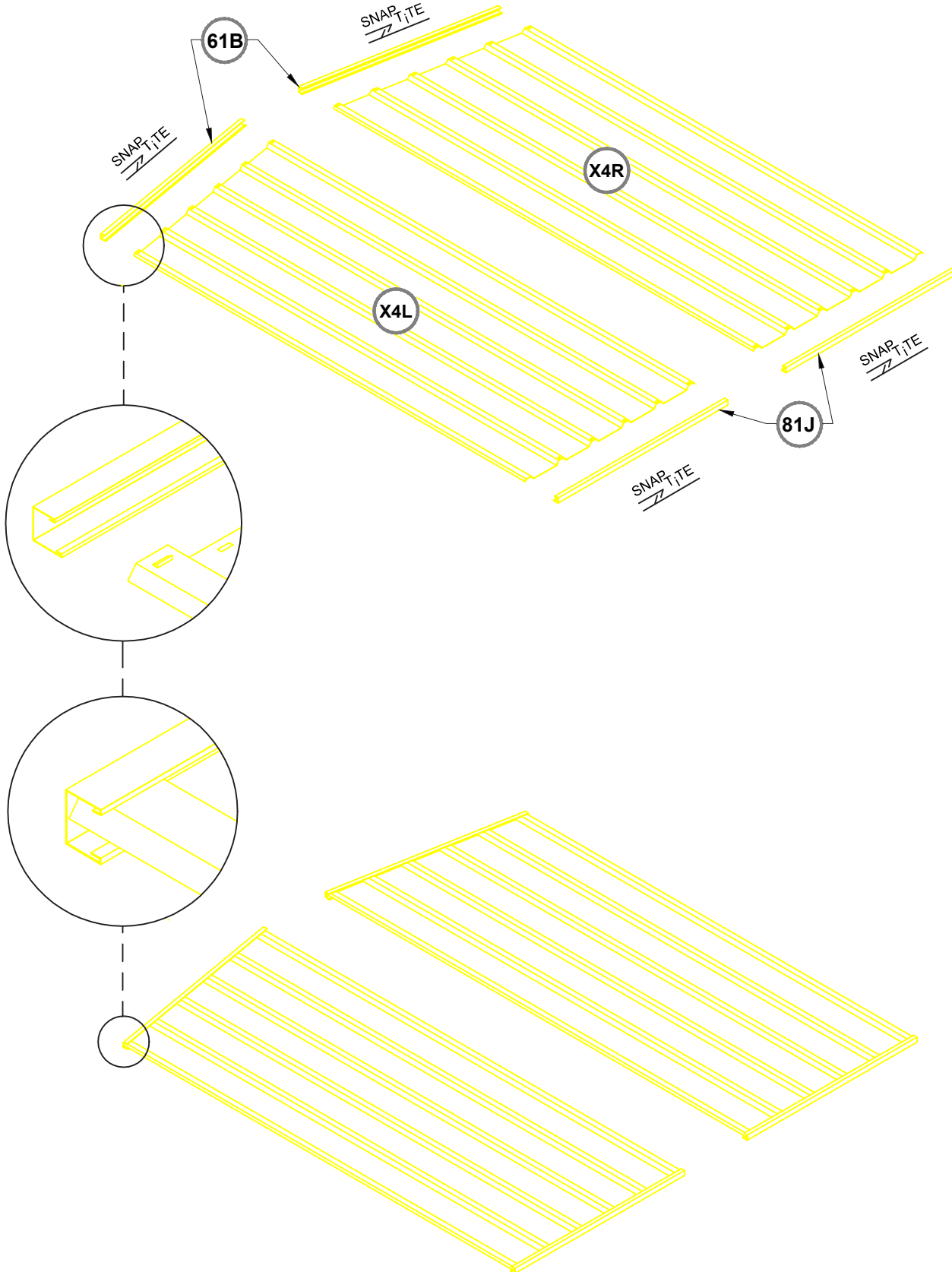



ROOF PANEL ASSEMBLY

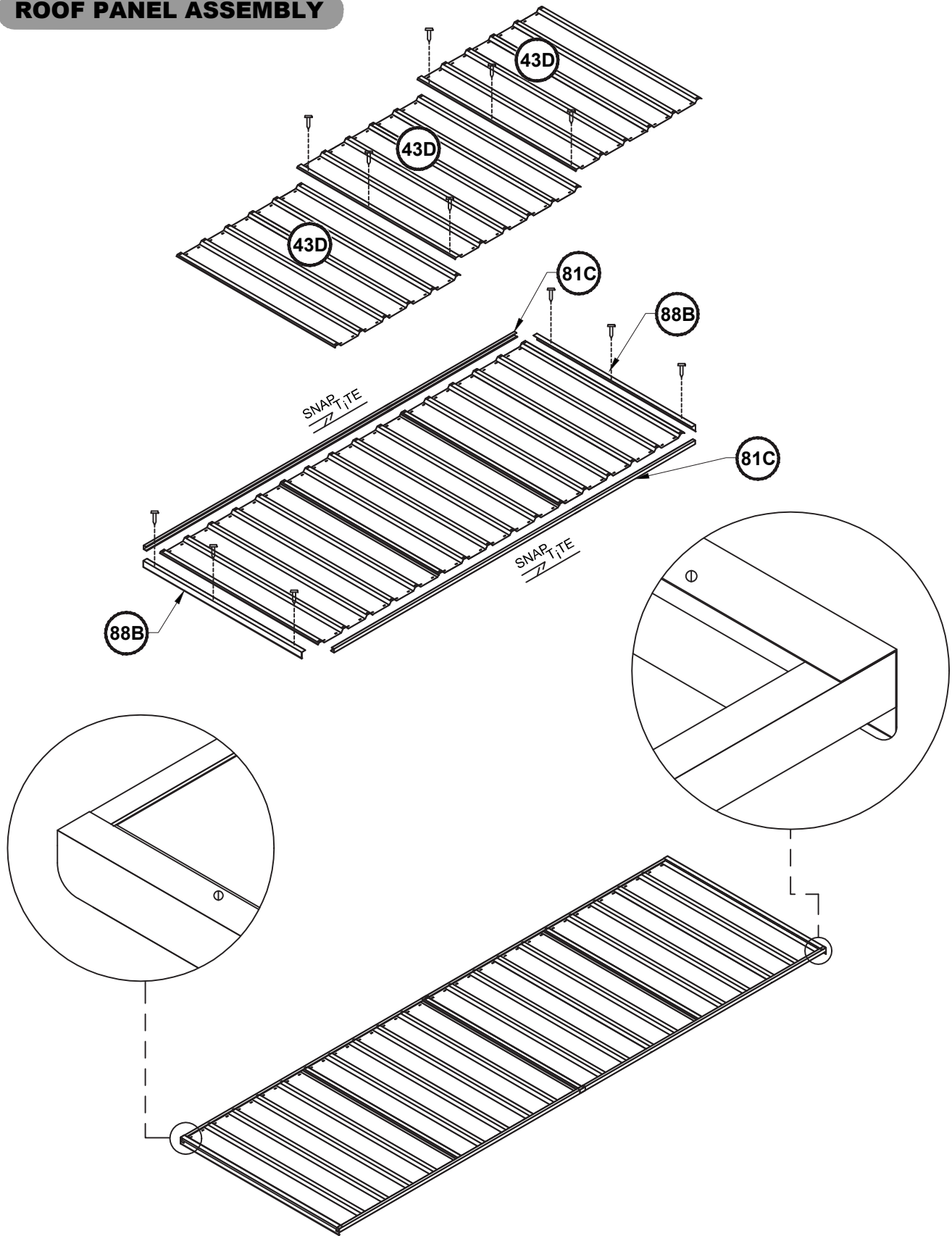



FRONT PANEL ASSEMBLY

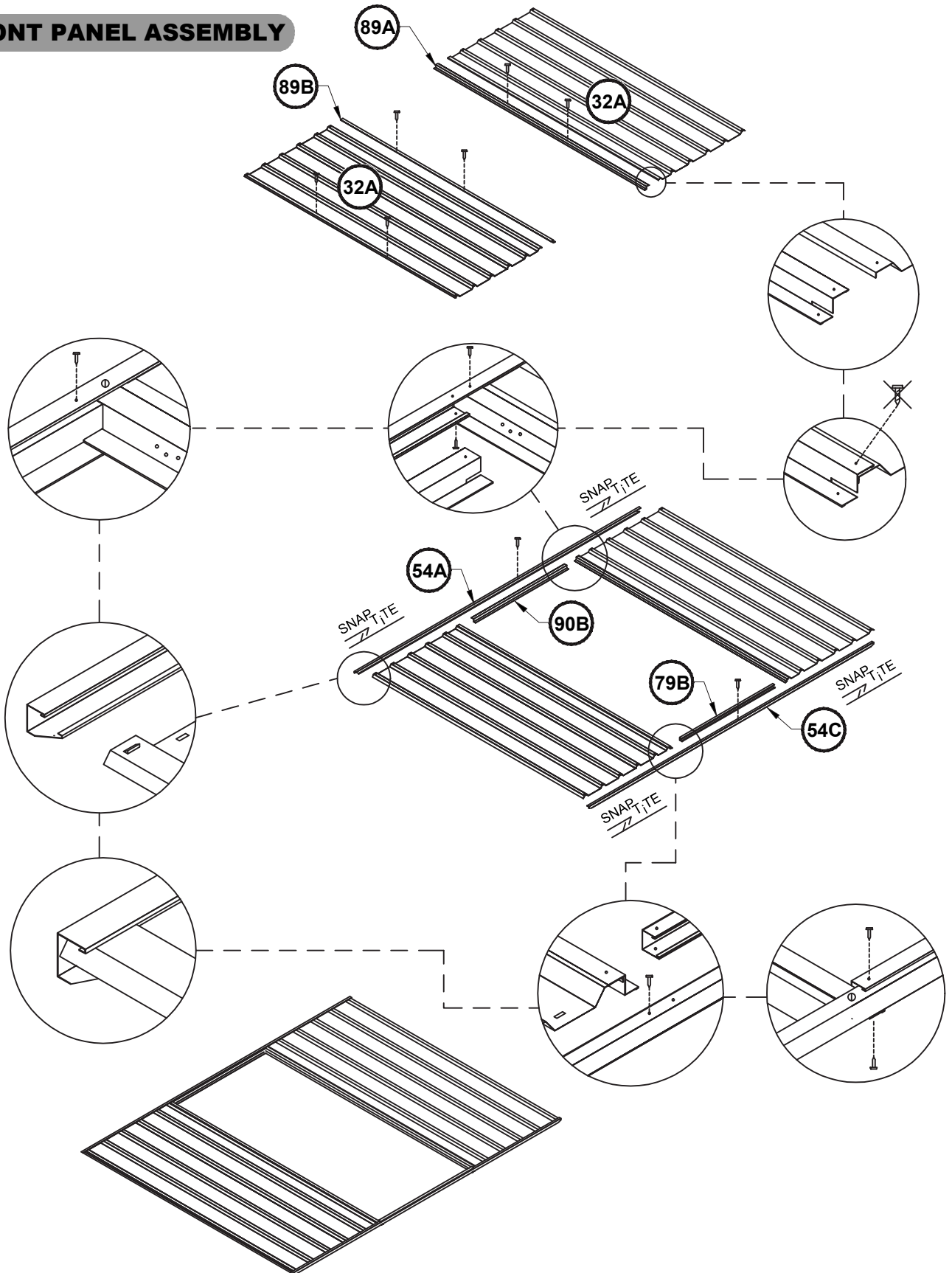

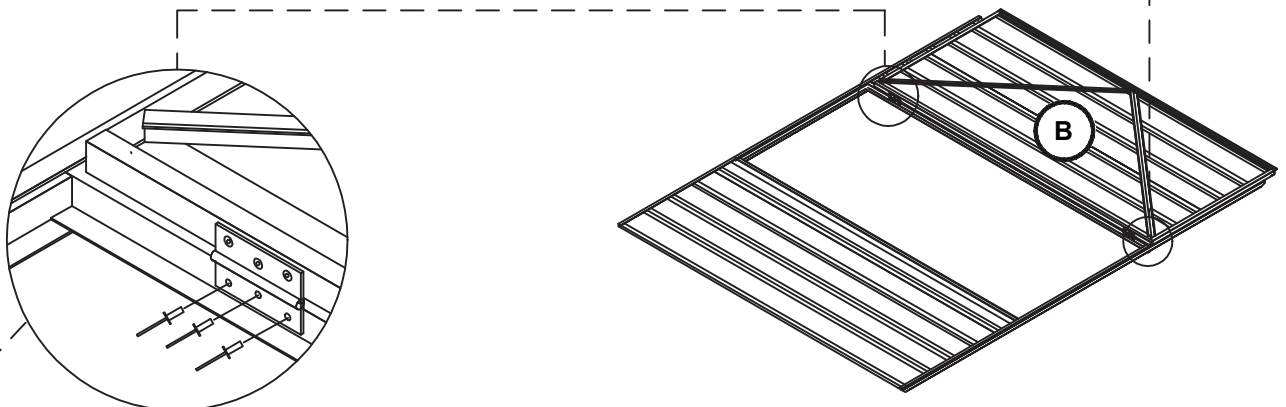
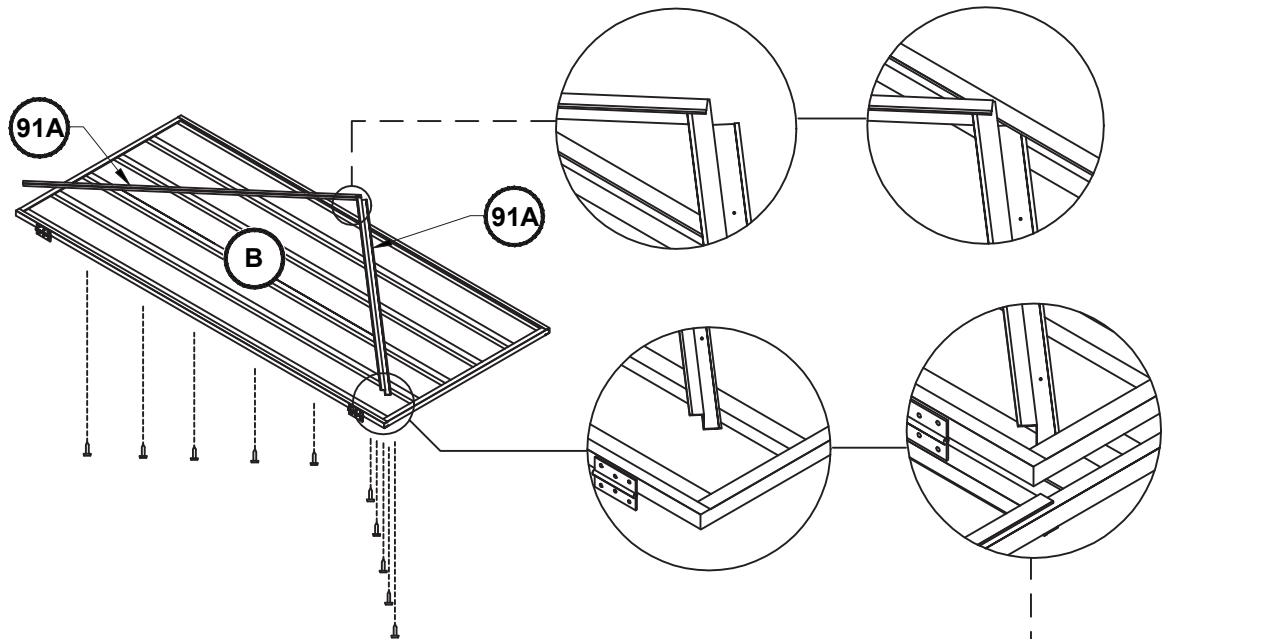

NOTE: NUTS AND BOLTS (SUPPLIED) MAY BE USED INSTEAD OF POP RIVETS (SUPPLIED) BY SIMPLY ENLARGING THE HINGE HOLE SETS IN THE JAMB USING A 4mm (0.16") DRILL BIT

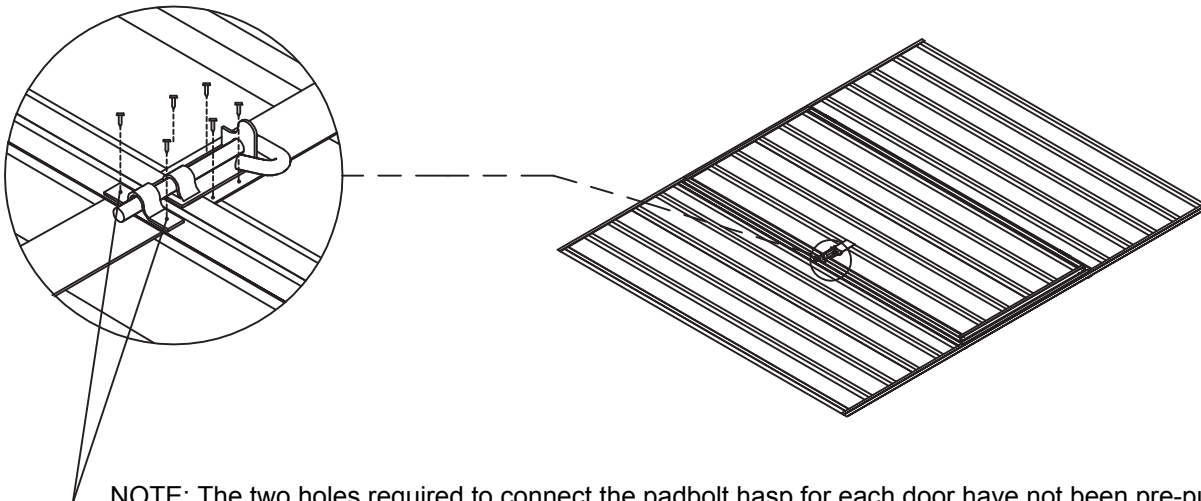

NOTE: The two holes required to connect the padbolt hasp for each door have not been pre-punched, to allow for proper alignment. position each hasp centrally over the padbolt shaft, and drill 3mm (0.12") holes and secure with screws



PANEL CONSTRUCTION

NOTE: Take care to ensure that both front and rear wall panels are not positioned upside down. The top channel of each panel is pre-punched for attaching roof sheet. The base channels are not pre-punched.

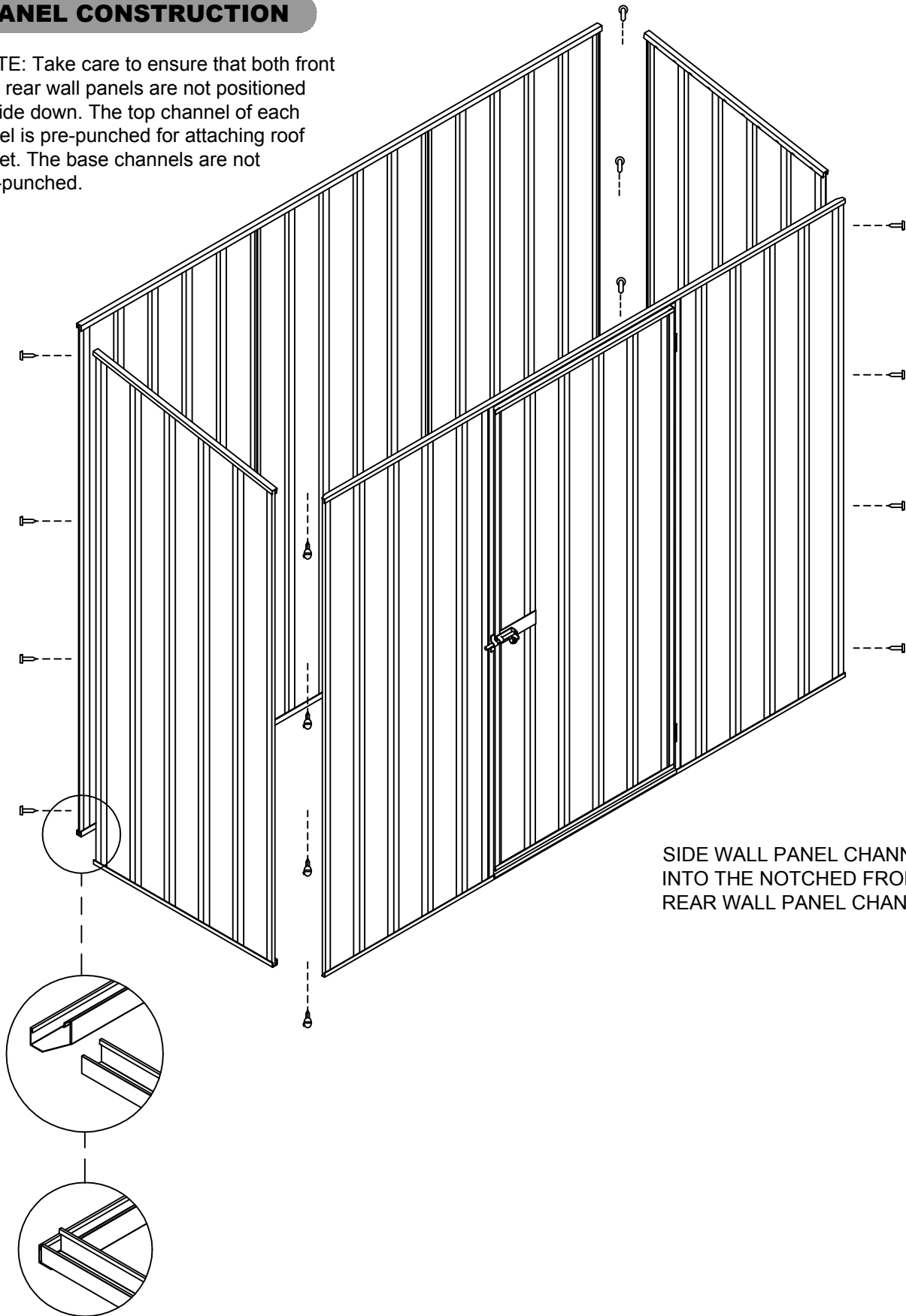

SIDE WALL PANEL CHANNELS FIT INTO THE NOTCHED FRONT AND REAR WALL PANEL CHANNELS



ANCHORING OF SHED



FINAL CONSTRUCTION

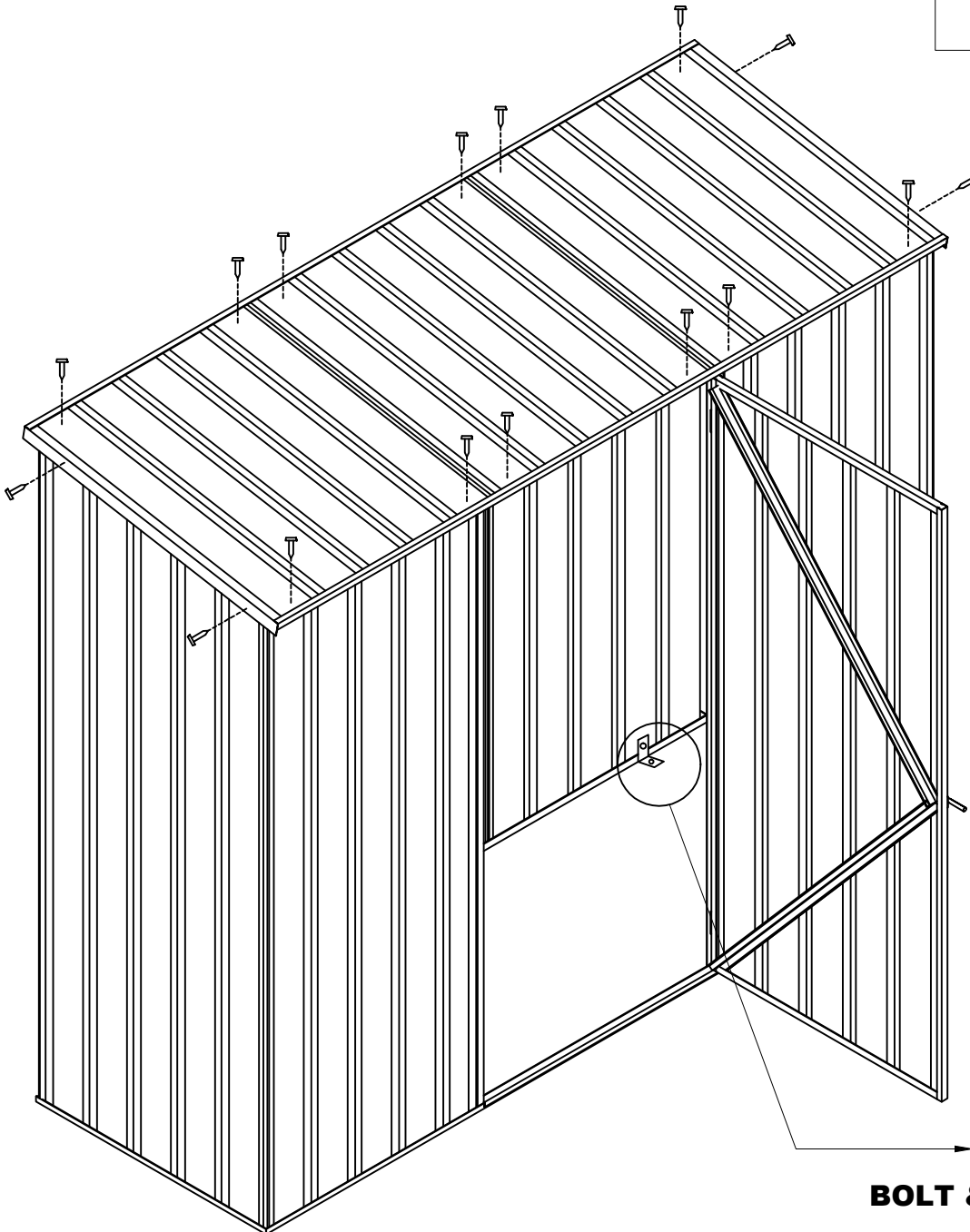

- EACH ANCHOR CONSISTS OF ONE NUT, BOLT, DYNABOLT AND STEEL ANGLE
- DRILL A 10mm (0.39") HOLE INTO THE WALL SHEET
- DRILL A 10mm (0.39") HOLE INTO THE CONCRETE

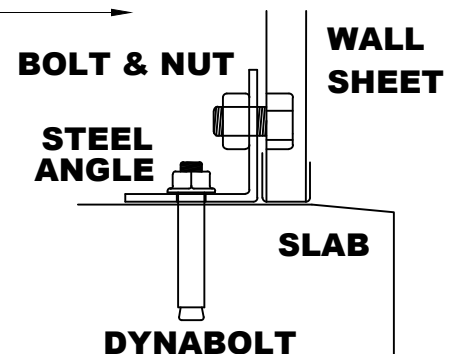



EXPORT PRODUCT WARRANTY AGAINST DEFECTS

Congratulations on your purchase of an ABSCO SHED

ABSCO SHEDS, including garden sheds, garden beds, aviaries, storage units, garages, awnings and carports are made using high quality Australian made steel.

We are pleased to advise we warrant that the steel coating will not rust, crack, flake peel or blister for 12 years from date of purchase.

This warranty does not apply to surface deterioration of panels caused by 'Swarf' (Tiny particles of steel debris left from cutting, grinding or drilling operations) that has not been removed after building construction, or as a result of contact with damp soil, chemicals, fertilisers or other corrosive substances.

This warranty covers any Absco product used for normal domestic use and installed in accordance with the installation instructions.

This warranty does NOT cover Damage caused by storms, wind, rain, snow or poor foundations.

This warranty does NOT cover ABSCO products installed in severe coastal, industrial or other highly corrosive environments. The warranty does not cover fasteners (screws, nuts, bolts, rivets, hasps or sliding padbolts).

The warranty is limited to replacement and delivery of components and does not include any labour or installation costs. The benefits given by the warranty are in addition to your other rights and remedies under a law in relation to the goods or services to which the warranty relates.

In the unlikely event a warranty claim is made, it must be supported by photographic evidence and details of the defect, including component part numbers, together with proof of purchase documentation (or on-line registration of purchase) and forwarded to the address below. Upon receipt of the warranty claim, the Customer Service Manager will contact you within three business days to advise you of the assessment outcome of the claim, which may include your expenses incurred in making the claim.

THE CUSTOMER SERVICE MANAGER, ABSCO SHEDS, PO BOX 119 ACACIA RIDGE QLD AUSTRALIA 4110

PHONE: +61 1800 029701 EMAIL: warranty@absco.com.au

Issued 16 July 2019