

SETUP & OPERATION MANUAL

FEATURES

- Precision cuts with laser alignment system
- Comfortable horizontal D-Handle
- Bevel cuts up to 45° left
- Miter cuts up to 45° left and right
- 10 in. saw blade with carbide-tipped teeth
- Powerful 15 A motor
- With:
 - Adjustable cut-depth for dados
 - Shaft lock for trouble-free blade changes
 - Easy-access motor brushes
- Includes:
 - Dust bag
 - Hold down clamp
 - Table side extension bars
 - Rear stabilization bar

SPECIFICATIONS

- 120 V ~ 60 Hz 15 A motor
- No-load speed: 4800 rpm
- Maximum cut capacity: 5.5" x 2-5/8" (140 x 67 mm)
- Net weight: 24 lb. (11 kg)

General International
Power Products, LLC
6243 Industrial Parkway
Whitehouse, OH 43571 USA

website: www.gipowerproducts.com

10 inch Compound Miter Saw with Laser

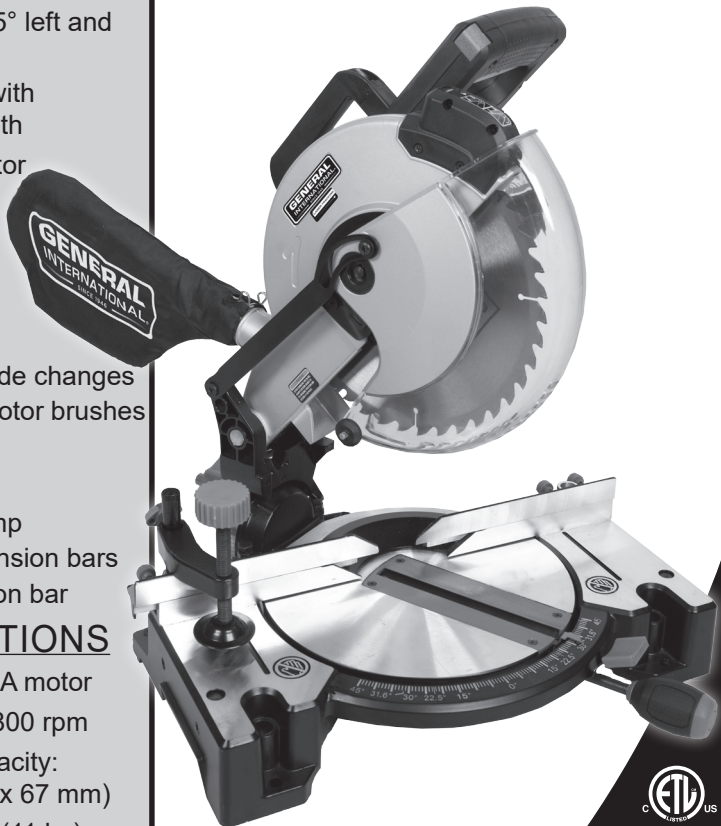

Model # MS3003

GENERAL
INTERNATIONAL
SINCE 1946

MS3003 Manual v.200908

TABLE OF CONTENTS

WARRANTY _____	4
WARRANTY _____	5
PROP 65 _____	6
PRODUCT SPECIFICATIONS _____	6
SYMBOLS _____	7
SAFETY SYMBOLS _____	8
POWER TOOL SAFETY _____	9
GENERAL SAFETY INSTRUCTIONS _____	9
COMPOUND MITER SAW COMPOUND MITER SAW SAFETY _____	10
SPECIFIC SAFETY INSTRUCTIONS _____	11
ELECTRICAL REQUIREMENTS AND SAFETY _____	13
POWER SUPPLY AND MOTOR SPECIFICATIONS _____	13
ELECTRICAL REQUIREMENTS _____	13
GUIDELINES FOR EXTENSION CORDS _____	14
ACCESSORIES AND ATTACHMENTS _____	15
RECOMMENDED ACCESSORIES _____	15
ACCESSORIES _____	15
BLADE INFORMATION _____	15
TOOLS NEEDED FOR ASSEMBLY _____	16
UNPACKING YOUR MITER SAW _____	17
KNOW YOUR SLIDING COMPOUND MITER SAW _____	18
GLOSSARY OF TERMS _____	18
ASSEMBLY AND ADJUSTMENT _____	21
CUTTING HEAD _____	21
INSTALLING THE MITER HANDLE _____	22
INSTALLING THE DUST BAG _____	22
INSTALLING THE REAR EXTENSION STAY _____	22
INSTALLING THE HOLD-DOWN CLAMP _____	22
REMOVING AND INSTALLING THE BLADE _____	23
ADJUSTMENTS _____	25
ADJUSTING FENCE SQUARENESS _____	25
MITER SCALE _____	25
ASSEMBLY AND ADJUSTMENT _____	25
CUTTING ARM TRAVEL _____	26
BEVEL STOP ADJUSTMENT _____	27
MOUNTING THE MITER SAW _____	28
LASER _____	29
MOUNTING _____	29
LASER _____	30
SAFETY INSTRUCTIONS FOR BASIC SAW OPERATION _____	31
OPERATION _____	31
MAKING A BASIC CUT _____	34

TABLE OF CONTENTS

BASIC SAW OPERATIONS	35
MITER CUT	35
BEVEL CUT	36
COMPOUND CUT	36
CUTTING BOWED MATERIAL	37
CUTTING BASE MOLDING	37
CUTTING CROWN MOLDING	38
CROWN MOLDING BEVEL/MITER SETTINGS	39
CROWN MOLDING CHART	40
REPLACING CARBON BRUSHES	41
LOWER BLADE GUARD	41
MAINTENANCE	41
LUBRICATION	42
TROUBLESHOOTING GUIDE	42
TROUBLESHOOTING GUIDE - MOTOR	43
TROUBLESHOOTING GUIDE - SAW OPERATION	43
PARTS LIST	45
EXPLODED DIAGRAM	48

WARRANTY

THANK YOU

for choosing this General International machine. This tool has been carefully tested and inspected before shipment and if properly used and maintained, will provide you with years of reliable service. To ensure optimum performance and trouble-free operation, and to get the most from your investment, please take the time to read this manual before assembling, installing and operating the unit.

The manual's purpose is to familiarize you with the safe operation, basic function, and features of this tool as well as the set-up, maintenance and identification of its parts and components. This manual is not intended as a substitute for formal woodworking instruction, nor to offer the user instruction in the craft of woodworking. If you are not sure about the safety of performing a certain operation or procedure, do not proceed until you can confirm, from knowledgeable and qualified sources, that it is safe to do so.

Once you've read through these instructions, keep this manual handy for future reference.

GENERAL® INTERNATIONAL WARRANTY

All component parts of General® International products are carefully inspected during all stages of production and each unit is thoroughly inspected upon completion of assembly.

2-YEAR LIMITED WARRANTY

All products are warranted for a period of 2 years (24 months) from the date of purchase. General® International agrees to repair or replace any part or component which upon examination, proves to be defective in either workmanship or material to the original purchaser during this 2-year warranty period, subject to the "conditions and exceptions" as listed below. Repairs made without the written consent of General International will void the warranty.

DISCLAIMER

The information and specifications in this manual pertain to the unit as it was supplied from the factory at the time of printing. Because we are committed to making constant improvements, General International reserves the right to make changes to components, parts or features of this unit as deemed necessary, without prior notice and without obligation to install any such changes on previously delivered units. Reasonable care is taken at the factory to ensure that the specifications and information in this manual corresponds with that of the unit with which it was supplied. However, special orders and "after factory" modifications may render some or all information in this manual inapplicable to your machine. Further, as several generations of this tool model and several versions of this manual may be in circulation, if you own an earlier or later version of this unit, this manual may not depict your machine exactly. If you have any doubts or questions contact your retailer or our support line with the model and serial number of your unit for clarification.

WARRANTY

TO FILE A CLAIM

To file a claim under our Standard 2-year Limited Warranty, all defective parts, components or machinery must be returned freight or postage prepaid to General® International, or to a nearby distributor, repair center or other location designated by General® International. For further details contact our service department: **USA toll-free (844) 877-5234 or (419) 877-5234 / Canada toll-free (888) 949-1161 or (604) 420-2299** or through our website: **www.gipowerproducts.com**.

Along with the return of the product being claimed for warranty, a copy of the original proof of purchase and a “letter of claim” must be included (a warranty claim form can also be used and can be obtained, upon request, from General® International or an authorized distributor) clearly stating the model and serial number of the unit (if applicable) and including an explanation of the complaint or presumed defect in material or workmanship.

CONDITIONS AND EXCEPTIONS

This coverage is extended to the original purchaser only. Prior warranty registration is not required but documented proof of purchase, i.e. a copy of original sales invoice or receipt showing the date and location of the purchase as well as the purchase price paid, must be provided at the time of claim.

Warranty does not include failures, breakage or defects deemed after inspection by General® International to have been directly or indirectly caused by or resulting from; improper use, or lack of or improper maintenance, misuse or abuse, negligence, accidents, damage in handling or transport, or normal wear and tear of any generally considered consumable parts or components.

Repairs made without the written consent of General® International will void all warranty.

READ ALL INSTRUCTIONS BEFORE OPERATING

SAVE THESE INSTRUCTIONS

Before attempting to operate your new tool, please read these instructions thoroughly. You will need these instructions for the safety warnings, precautions, assembly, operation, maintenance procedures, parts list and diagrams. Keep your invoice with these instructions. Write the invoice number on the inside of front cover. Keep the instructions and invoice in a safe, dry place for future reference.

PROP 65



CALIFORNIA PROPOSITION 65

This product can expose you to chemicals including DEHP, which is known to the State of California to cause cancer and birth defects or other reproductive harm. For more information go to www.P65Warnings.ca.gov.

SAVE THESE INSTRUCTIONS!

READ ALL INSTRUCTIONS!

PRODUCT SPECIFICATIONS

MOTOR:

Power source	120V AC, 60 Hz, 15 Amp
Speed	4800 RPM (no load)
Electric brake	Yes
Double Insulated	No

BLADE:

Diameter	10 in.
Arbor hole	5/8 in.

MITER SAW

Rotating table:

Miter Detent Stops	0°, 15°, 22.5°, 31.6°, 45° Right & Left
Bevel Positive Stops	0°, 45° Left

Cutting capacity:

Crosscut	2-5/8 in. x 5-1/2 in.
Miter 45° Right & Left	2-5/8 in. x 3-7/8 in.
Bevel 45° Left	1-1/2 in. x 5-1/2 in.
45° Miter and 45° Bevel Left	1-1/2 in. x 3-7/8 in.

▲ WARNING

To avoid electrical hazards, fire hazards or damage to the tool, use proper circuit protection. This tool is wired at the factory for 110-120 Volt operation. It must be connected to a 110-120 Volt / 9 Ampere time delay fuse or circuit breaker. To avoid shock or fire, replace power cord immediately if it is worn, cut or damaged in any way. Before using your tool, it is critical that you read and understand these safety rules. Failure to follow these rules could result in serious injury to you or damage to the tool.

SYMBOLS

WARNING ICONS

Your power tool and its Operator's Manual may contain "WARNING ICONS" (a picture symbol intended to alert you to, and/or instruct you how to avoid, a potentially hazardous condition). Understanding and heeding these symbols will help you operate your tool better and safer. Shown below are some of the symbols you may see.



SAFETY ALERT: Precautions that involve your safety.



PROHIBITION



WEAR EYE PROTECTION: Always wear safety goggles or safety glasses with side shields.



WEAR RESPIRATORY AND HEARING PROTECTION: Always wear respiratory and hearing protection.



READ AND UNDERSTAND INSTRUCTION MANUAL: To reduce the risk of injury, user and all bystanders must read and understand instruction manual before using this product.



KEEP HANDS AWAY FROM BLADE: Failure to keep your hands away from the blade will result in serious personal injury.



SUPPORT AND CLAMP WORK

▲ DANGER

DANGER: Indicates an imminently hazardous situation, which, if not avoided, will result in death or serious injury.

▲ WARNING

WARNING: indicates a potentially hazardous situation which, if not avoided, could result in death or serious injury.

▲ CAUTION











CAUTION: indicates a potentially hazardous situation which, if not avoided, may result in minor or moderate injury.

CAUTION

CAUTION: used without the safety alert symbol indicates a potentially hazardous situation which, if not avoided, may result in property damage.

SAFETY SYMBOLS

Some of the following symbols may be used on this tool. Please study them and learn their meaning. Proper interpretation of these symbols will allow you to operate the tool better and more safely.

SYMBOL	NAME	DESIGNATION/EXPLANATION
V	Volts	Voltage
A	Amperes	Current
Hz	Hertz	Frequency (cycles per second)
W	Watt	Power
min	Minutes	Time
~	Alternating Current	Type of current
≡	Direct Current	Type or a characteristic of current
n_0	No Load Speed	Rotational speed, at no load
	Class II Construction	Double-insulated construction
.../min	Per Minute	Revolutions, strokes, surface speed, orbits, etc., per minute
	Wet Conditions Alert	Do not expose to rain or use in damp locations.
	Read The Operator's Manual	To reduce the risk of injury, user must read and understand operator's manual before using this product.
	Eye Protection	Always wear safety goggles or safety glasses with side shields and a full face shield when operating this product.
	Safety Alert	Precautions that involve your safety.
	No-Hands Symbol	Failure to keep your hands away from the blade will result in serious personal injury.
	No-Hands Symbol	Failure to keep your hands away from the blade will result in serious personal injury.
	No-Hands Symbol	Failure to keep your hands away from the blade will result in serious personal injury.
	No-Hands Symbol	Failure to keep your hands away from the blade will result in serious personal injury.
	Hot Surface	To reduce the risk of injury or damage, avoid contact with any hot surface.



POWER TOOL SAFETY

GENERAL SAFETY INSTRUCTIONS BEFORE USING THIS POWER TOOL



Safety is a combination of common sense, staying alert and knowing how to use your power tool.

WARNING

To avoid mistakes that could cause serious injury, do not plug the tool in until you have read and understood the following.

-  **READ** and become familiar with the entire Operator's Manual. **LEARN** the tool's application, limitations and possible hazards.
- KEEP GUARDS IN PLACE** and in working order.
- REMOVE ADJUSTING KEYS AND WRENCHES.** Form the habit of checking to see that keys and adjusting wrenches are removed from the tool before turning ON.
- KEEP WORK AREA CLEAN.** Cluttered areas and benches invite accidents.
- DO NOT USE IN DANGEROUS ENVIRONMENTS.** Do not use power tools in damp locations, or expose them to rain or snow. Keep work area well lit.
- KEEP CHILDREN AWAY.** All visitors and bystanders should be kept a safe distance from work area.
- MAKE WORKSHOP CHILD PROOF** with padlocks, master switches or by removing starter keys.
- DO NOT FORCE THE TOOL.** It will do the job better and safer at the rate for which it was designed.
- USE THE RIGHT TOOL.** Do not force the tool or an attachment to do a job for which it was not designed.
- USE PROPER EXTENSION CORDS.** Make sure your extension cord is in good condition. When using an extension cord, be sure to use the one heavy enough to carry the current that the product will draw. An undersized cord will result in a drop in line voltage and in loss of power which will cause the tool overheat. The table on page 11 shows the proper wire gauge size usage to each extension cord length and ampere rating. If in doubt, use the next heavier gauge. The smaller the gauge number, the heavier the cord.
- WEAR PROPER APPAREL.** Do not wear loose clothing, gloves, neckties, rings, bracelets or other jewelry which may get caught in moving parts. Nonslip footwear is recommended. Wear protective hair covering to contain long hair.
-  **ALWAYS WEAR EYE PROTECTION.** Any power tool can throw foreign objects into the eyes and could cause permanent eye damage. **ALWAYS** wear Safety Goggles (not glasses) that comply with ANSI. **NOTE:** Glasses or goggles not in compliance with ANSI Z87.1 could seriously injure you when they break.
-  **WEAR A FACE MASK OR DUST MASK.** Sawing operation produces dust.

POWER TOOL SAFETY

14.  **SECURE WORK.** Use clamps or a vice to hold work when practical. It is safer than using your hand and it frees both hands to operate the tool.
15. **DISCONNECT TOOLS FROM POWER SOURCE** before servicing, and when changing accessories such as blades, bits and cutters.
16. **REDUCE THE RISK OF UNINTENTIONAL STARTING.** Make sure switch is in the OFF position before plugging the tool in.
17. **USE RECOMMENDED ACCESSORIES.** Consult this Operator's Manual for recommended accessories. The use of improper accessories may cause risk of injury to yourself or others.
18. **NEVER STAND ON THE TOOL.** Serious injury could occur if the tool is tipped or if the cutting tool is unintentionally contacted.
19. **CHECK FOR DAMAGED PARTS.** Before further use of the tool, a guard or other part that is damaged should be carefully checked to determine that it will operate properly and perform its intended function – check for alignment of moving parts, binding of moving parts, breakage of parts, mounting and any other conditions that may affect its operation. A guard or other part that is damaged should be properly repaired or replaced.
20. **NEVER LEAVE THE TOOL RUNNING UNATTENDED. TURN THE POWER "OFF".** Do not walk away from a running tool until the blade comes to a complete stop and the tool is unplugged from the power source.
21. **DO NOT OVERREACH.** Keep proper footing and balance at all times. NEVER reach across the path of the cutting blade while tool is in operation.
22. **MAINTAIN TOOLS WITH CARE.** Keep tools sharp and clean for best and safest performance. Follow instructions for lubricating and changing accessories.
23. **DO NOT** use power tool in presence of flammable liquids or gases.
24. **DO NOT** operate the tool if you are under the influence of any drugs, alcohol or medication that could affect your ability to use the tool properly.
25. **WARNING:** Dust generated from certain materials can be hazardous to your health. Always operate saw in well-ventilated area and provide for proper dust removal.
26.  **DANGER** People with electronic devices, such as pacemakers, should consult their physician(s) before using this product. Operation of electrical equipment in close proximity to a heart pacemaker could cause interference or failure of the pacemaker.
27.  **WEAR HEARING PROTECTION** to reduce the risk of induced hearing loss.

SAFETY

SPECIFIC SAFETY INSTRUCTIONS FOR THIS COMPOUND MITER SAW

1. **DO NOT USE THIN KERF BLADES** they can deflect, contact guard and can cause possible injury to the operator.
2. **DO NOT** operate the miter saw until it is completely assembled and installed according to these instructions.
3. **IF YOU ARE NOT** thoroughly familiar with the operation of miter saws, seek guidance from your supervisor, instructor or other qualified person.
4. **ALWAYS** hold the work firmly against the fence and table. **DO NOT** perform any operation free hand (use clamp wherever possible).
5. **KEEP HANDS** out of the path of the saw blade. If the workpiece you are cutting would cause your hands to be within 7-1/2 in. of the saw blade, the workpiece should be clamped in place before making the cut.
6. **BE SURE** the blade is sharp, runs freely and is free of vibration.
7. **ALLOW** the motor to come up to full speed before starting a cut.
8. **KEEP THE MOTOR AIR SLOTS CLEAN** and free of chips or dust.
9. **ALWAYS MAKE SURE** all handles are tight before cutting, even if the table is positioned in one of the positive stops.
10. **BE SURE** both the blade and the collar are clean and the arbor bolt is tightened securely.
11. **USE** only blade collars specified for your saw.
12. **NEVER** use blades larger in diameter than 10 inches.
13. **NEVER** apply lubricants to the blade when it is running.
14. **ALWAYS** check the blade for cracks or damage before operation. Replace a cracked or damaged blade immediately.
15. **NEVER** use blades recommended for operation at less than 4800 RPM.
16. **ALWAYS** keep the blade guards in place and use at all times.
17. **NEVER** reach around the saw blade.
18. **MAKE SURE** the blade is not contacting the workpiece before the switch is turned ON.
19. **IMPORTANT:** After completing the cut, release the trigger and wait for the blade to stop before returning the saw to the raised position.
20. **MAKE SURE** the blade has come to a complete stop before removing or securing the workpiece, changing the workpiece angle or changing the angle of the blade.
21. **NEVER** cut metals or masonry products with this tool. This miter saw is designed for use on wood and wood-like products.
22. **NEVER** cut small pieces. If the workpiece being cut would cause your hand or fingers to be within 6-3/4 in. of the saw blade the workpiece is too small.

COMPOUND MITER SAW SAFETY

23. **PROVIDE ADEQUATE SUPPORT** to the sides of the saw table for long work pieces.
24. **NEVER USE THE MITER SAW** in an area with flammable liquids or gases.
25. **NEVER USE SOLVENTS** to clean plastic parts. Solvents could possibly dissolve or otherwise damage the material.
26. **SHUT OFF THE POWER** before servicing or adjusting the tool.
27. **DISCONNECT THE SAW** from the power source and clean the machine when finished using.
28. **MAKE SURE** the work area is clean before leaving the machine.
29. **SHOULD ANY PART OF YOUR MITER SAW BE MISSING, damaged, or fail in any way, or any electrical component fail to perform properly, lock the switch and remove the plug from the power supply outlet. Replace missing, damaged, or failed parts before resuming operation.**
30. **BECAUSE OF THE DOWNWARD CUTTING MOTION,** your safety requires that you stay very alert to keeping hands and fingers away from the path that the blade travels.
31. **BE SURE ALL GUARDS ARE IN PLACE** and working. If a guard seems slow to return to its normal position or "hangs-up", adjust or repair it immediately. Be alert at all times - especially during repetitive, monotonous operations. Don't be lulled into carelessness due to a false sense of security. Blades are extremely unforgiving. Clean the lower guard frequently to help visibility and movement. Unplug before adjustment or cleaning.
32. **ABRASIVE CUT-OFF WHEELS SHOULD NOT BE USED** on miter saws. Miter saw guards are not appropriate for abrasive cut-off wheels.
33. **TO AVOID LOSS OF CONTROL OR PLACING HANDS IN THE PATH OF THE BLADE, HOLD OR CLAMP** all material securely against the fence when cutting. Do not perform operations freehand.
34. **SUPPORT LONG MATERIAL** at the same height as the saw table.
35. **AFTER COMPLETING A CUT, RELEASE THE TRIGGER SWITCH AND ALLOW THE BLADE TO COME TO A COMPLETE STOP,** then raise the saw blade from the workpiece.
36. **LOCK THE MITER SAW HEAD IN THE DOWN POSITION** during transport or when not in use.
37. **DRY RUN** - It is important to know where the blade will intersect with the workpiece during cutting operations. Always perform a simulated cutting sequence with the power tool switched OFF to gain an understanding of the projected path of the saw blade. At some extreme angles, the right or left side fence might have to be removed to ensure proper clearance prior to making a cut.

ELECTRICAL REQUIREMENTS AND SAFETY

POWER SUPPLY AND MOTOR SPECIFICATIONS

The AC motor used in this saw is a universal, nonreversible type. See “MOTOR” in the “PRODUCT SPECIFICATIONS” section on page 3.

▲ WARNING

To avoid electrical hazards, fire hazards, or damage to the tool, use proper circuit protection. Your saw is wired at the factory for 120 V operation. Connect to a 120 V, 15 A circuit and use a 15 A time delay fuse or circuit breaker. To avoid shock or fire, if power cord is worn or cut, or damaged in any way, have it replaced immediately.

ELECTRICAL REQUIREMENTS DOUBLE INSULATED □

The power tool is double insulated to provide a double thickness of insulation between you and tool's electrical system. All exposed metal parts are isolated from the internal metal motor components with protecting insulation.

Replacement parts – When servicing use only identical replacement parts.

Polarized plugs – This saw has a plug that looks like the one shown below:

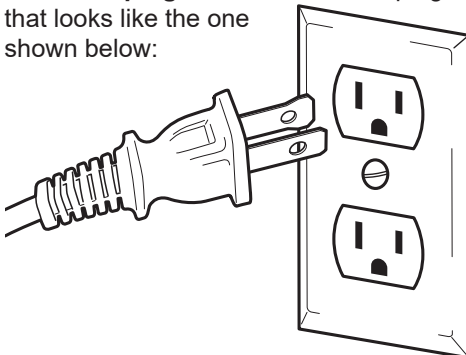

To reduce the risk of electrical shock, this saw has a polarized plug (one blade is wider than the other). This plug will fit in a polarized outlet only one way. If the plug does not fit fully in the outlet, reverse the plug. If it still does not fit, contact a qualified electrician to install the proper outlet. Do not change the plug in any way.

▲ WARNING

Double insulation does not take the place of normal safety precautions when operating this tool.

To avoid electrocution:

1. Use only identical replacement parts when servicing a tool with double insulation. Servicing should be performed by a qualified technician.
2. Do not use power tools in wet or damp locations or expose them to rain or snow.

MOTOR SAFETY PROTECTION IMPORTANT:

To avoid motor damage, the motor should be blown out or vacuumed frequently to keep sawdust from interfering with the motor ventilation.

1. **CONNECT** this saw to a 120 V, 15 A circuit with a 15 A time-delay fuse or circuit breaker. Using the wrong size fuse can damage the motor.
2. If the motor won't start, release the trigger switch immediately. **UNPLUG THE SAW**. Check the saw blade to make sure it turns freely. If the blade is free, try to start the saw again. If the motor still does not start, refer to the **TROUBLESHOOTING GUIDE**.

ELECTRICAL REQUIREMENTS AND SAFETY

3. If the tool suddenly stalls while cutting wood, release the trigger switch, unplug the tool, and free the blade from the wood. The saw may now be started and the cut finished.
4. **FUSES** may “blow” or circuit breakers may trip frequently if:
 - a. **MOTOR** is overloaded – overloading can occur if you feed too rapidly or make too many start/stops in a short time.
 - b. **LINE VOLTAGE** is more than 10% above or below the nameplate voltage rating. For heavy loads, the voltage at motor terminals must equal the voltage specified on the nameplate.
 - c. **IMPROPER** or dull saw blades are used.
5. Most motor troubles may be traced to loose or incorrect connections, overload, low voltage or inadequate power supply wiring. Always check the connections, the load and supply circuit if the motor doesn’t run well. Check minimum gauge for the length of cord you are using on the chart below.

GUIDELINES FOR EXTENSION CORDS

Use a proper extension cord. Make sure your extension cord is in good condition. When using an extension cord, be sure to use one heavy enough to carry the current your product will draw. An undersized cord will cause a drop in line voltage, resulting in loss of power and cause overheating. The table below shows the correct size to use depending on cord length and nameplate ampere rating. If in doubt, use the next heavier

gauge. The smaller the gauge number, the heavier the cord.

Be sure your extension cord is properly wired and in good condition. Always replace a damaged extension cord or have it repaired by a qualified person before using it. Protect your extension cords from sharp objects, excessive heat and damp or wet areas.

Use a separate electrical circuit for your tools. This circuit must not be less than a #14 wire with a 15 A time lag fuse. NOTE: When using an extension cord on a circuit with a #14 wire, the extension cord must not exceed 25 feet in length. Before connecting the tool to the power line, make sure the switch is in the OFF position and the electric current is rated the same as the current stamped on the motor nameplate, running at a lower voltage will damage the motor.

MINIMUM GAUGE FOR EXTENSION CORDS (AWG)

(When using 120 volts only)				
Ampere Rating		Total length of Cord		
More Than	Not More Than	25ft.	50ft.	100ft. 150ft.
0	6	18	16	16 14
6	10	18	16	14 12
10	12	16	16	14 12
12	16	14	12	Not Recommended

CAUTION

In all cases make certain the receptacle in question is properly grounded. If you are not sure, have a certified electrician check the receptacle.

ACCESSORIES AND ATTACHMENTS

RECOMMENDED ACCESSORIES

▲ WARNING

- Use only accessories recommended for this miter saw. Follow instructions that accompany accessories. Use of improper accessories may cause hazards.
- The use of any cutting tool except 10 in. saw blades which meet the requirements under recommended accessories is prohibited. Do not use accessories such as shaper cutters or dado sets. Ferrous metal cutting and the use of abrasive wheels is prohibited.
- Do not attempt to modify this tool or create accessories not recommended for use with this tool. Any such alteration or modification is misuse and could result in a hazardous condition leading to possible serious injury.

ACCESSORIES

Visit your local hardware department or purchase recommended accessories for this power tool.

▲ WARNING

- To avoid the risk of personal injury, do not modify this power tool or use accessories not recommended by General International.
- Read warnings and conditions on your CARBIDE TIPPED SAW BLADE. Do not operate the saw without the proper saw blade guard in place. Carbide is a very hard but brittle material. Care should be taken while mounting, using, and storing carbide tipped

blades to prevent accidental damage. Slight shocks, such as striking the tip while handling, can seriously damage the blade. Foreign objects in the workpiece, such as wire or nails, can also cause tips to crack or break off. Before using, always visually examine the blade and tips for bent blade, cracks, breakage, missing or loose tips, or other damage. Do not use if damage is suspected. Failure to heed safety instructions and warnings can result in serious bodily injury.

BLADE INFORMATION

- Always use a crosscut blade that is designed for cutting across the wood grain. NEVER use Rip, Combination, Plywood, Dado or Abrasive type saw blades at any time
- Always use a 10 in. diameter blade with either a 5/8 in. arbor hole, speed rating must be at least 5000 RPM.
- Read and understand all instructions provided with each blade before using on this miter saw.

There are two main materials used for saw blades; high-speed steel (HSS) and carbide tipped (TCT). While the HSS blades are generally less expensive than carbide tipped, TCT blades will stay sharper longer than HSS. As a general rule the more teeth per inch (TPI) the smoother the cut. Please read the information provided on the blade for more details for their use.

General Purpose Wood Cutting: 24 - 40 TPI
Fine Woodworking Cutting: 60 - 80 TPI
Non-ferrous Metal Cutting:
Use only special blades designed for cutting this type of material.

ACCESSORIES AND ATTACHMENTS

Plastic Cutting:

Use only special blades designed for cutting plastic.

NOTE: When cutting non-ferrous or plastic, be sure to clean up completely

after each use. Take special care with metal shavings after each cut, these can cause damage to the table top and a risk of fire in the dust bag. **ALWAYS WEAR EYE PROTECTION.**

TOOLS NEEDED FOR ASSEMBLY

Supplied



Blade Wrench



Hex Wrench
Fig. B

Not supplied

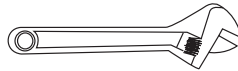

Adjustable Wrench

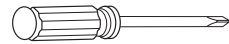

Phillips Screwdriver

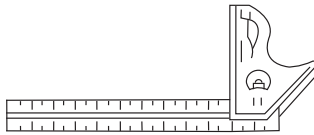

Combination Square

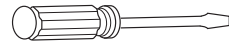

Slotted Screwdriver

COMBINATION SQUARE MUST BE TRUE

Draw light line on board along this edge.

Straight edge or a 3/4 in. board, this edge must be perfectly straight.

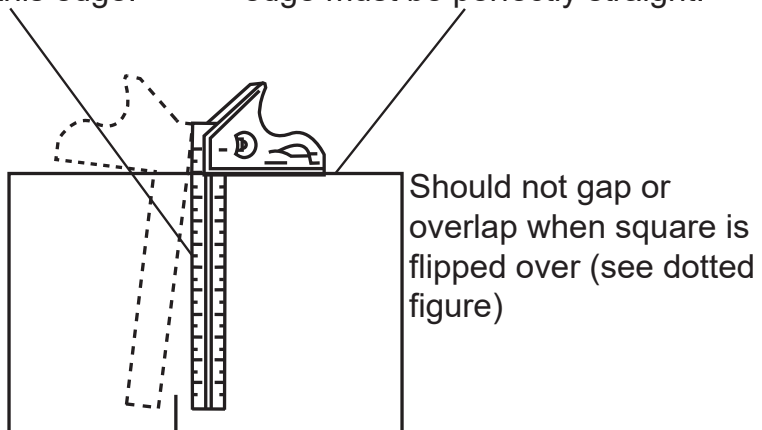

Should not gap or overlap when square is flipped over (see dotted figure)

Fig. C Gap from untrue square when flipped over.

UNPACKING YOUR MITER SAW

▲ WARNING

To avoid injury from unexpected starting or electrical shock, do not plug the power cord into a source of power during unpacking and assembly. This cord must remain unplugged whenever you are working on the saw.

1. Remove the miter saw from the carton.

IMPORTANT: Do not lift miter saw by the trigger switch handle. It may cause misalignment. Lift machine by the built-in carry handle (17, fig. D).

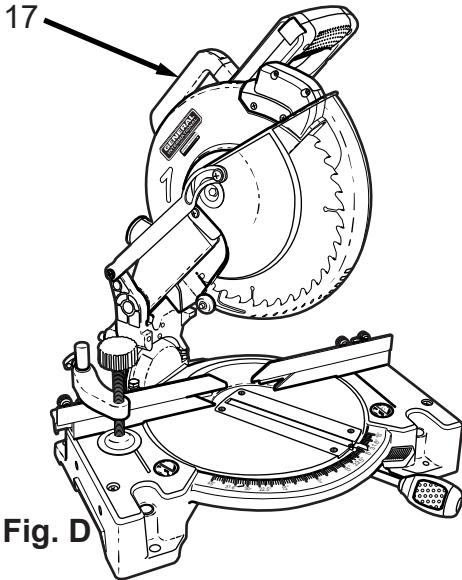

2. Place the saw on a secure stationary work surface.
3. Separate all parts from the packing material. Check each one with the illustration to make certain all items are accounted for before discarding any packing material.

▲ WARNING

If any part is missing or damaged, do not attempt to assemble the miter saw, or plug in the power cord until the missing or damaged part is correctly replaced. To avoid electric shock, use only identical replacement parts when servicing double insulated tools. Call USA toll-free (844) 877-5234 or (419) 877-5234 / Canada toll-free (888) 949-1161 or (604) 420-2299 or through our website: www.gipowerproducts.com for replacement parts.

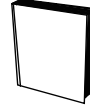

Operator's Manual

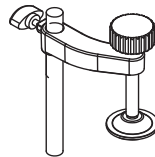

Hold-Down Clamp

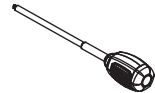

Miter Handle

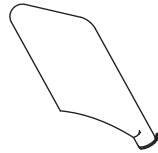

Dust Bag

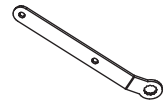

Blade Wrench



Batteries



Hex Key



Rear Extension Stay

Fig. E

KNOW YOUR SLIDING COMPOUND MITER SAW

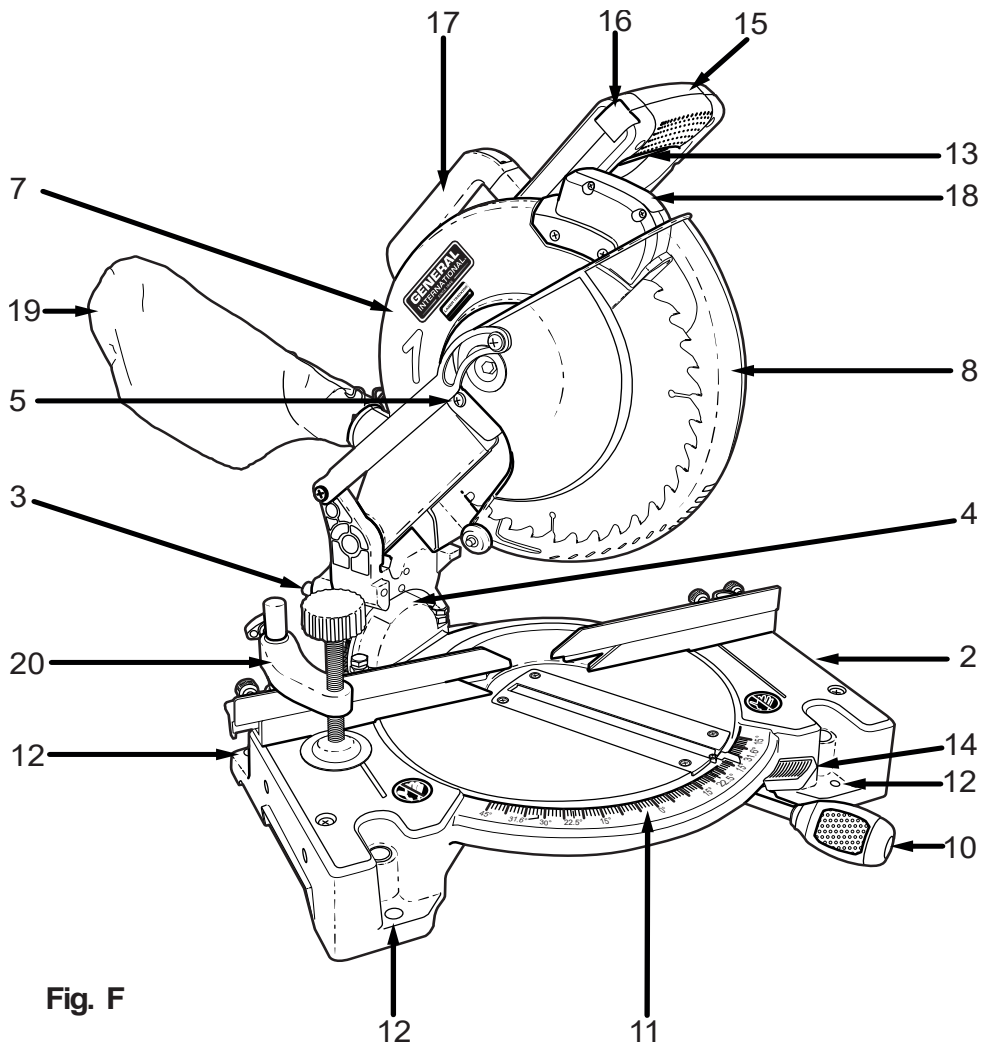

Fig. F

GLOSSARY OF TERMS

AMPERAGE (AMPS) – A measure of the flow of electric current. Higher ratings generally means the tool is suited for heavier use.

ARBOR LOCK – (1, fig. G) Allows the user to keep the blade from rotating while tightening or loosening the arbor bolt during blade replacement or removal.

BASE – (2, fig. F & G) Supports the table, holds accessories and allows for workbench or leg set mounting.

BEVEL LOCK HANDLE – (3, fig. F & G) Locks the miter saw at a desired bevel angle.

BEVEL SCALE – (4, fig. F & G) To measure the bevel angle of the saw blade 0° to 47° left.

KNOW YOUR SLIDING COMPOUND MITER SAW

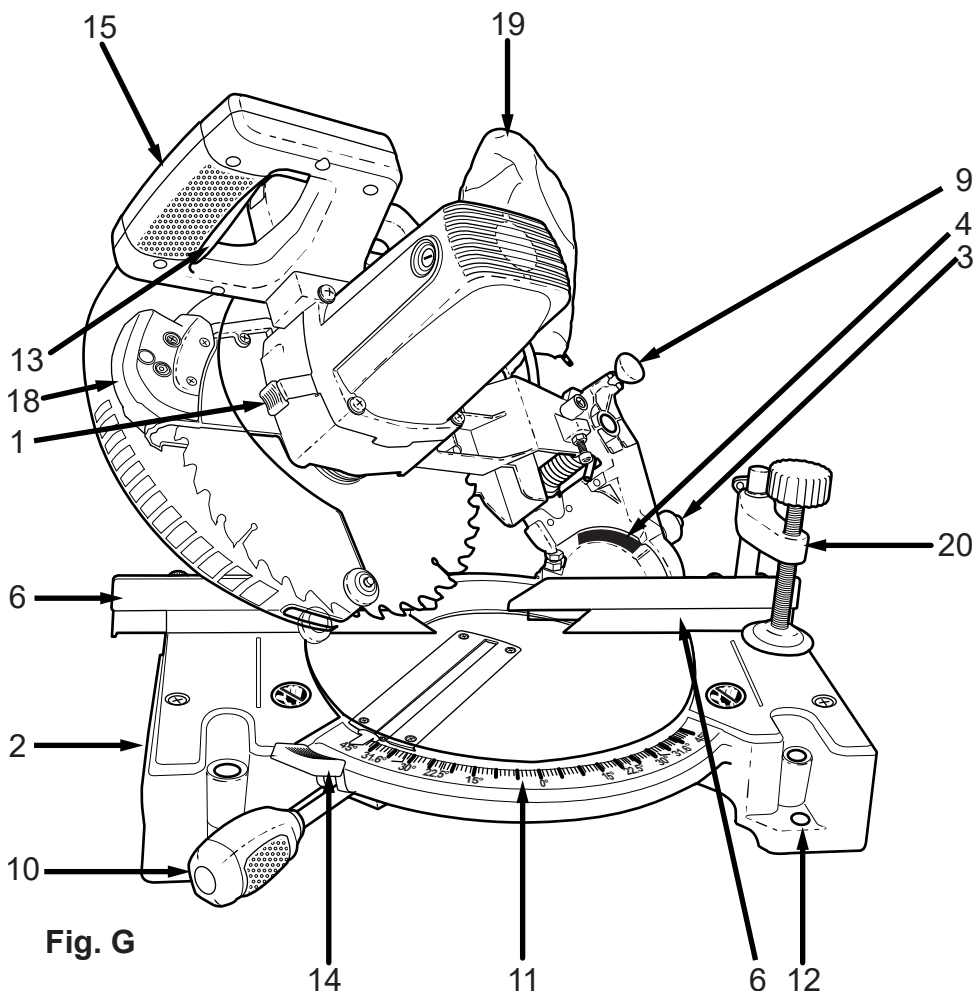

Fig. G

CARBIDE TIPPED – Extremely hard steel pieces with sharp cutting edges fastened to cutting tools such as saw blades.

COVER PLATE SCREW – (5, fig. F) Loosen this screw and rotate the plate for access to the blade arbor bolt.

EXTENSION CORD – An electric cord used between power tools and outlets to extend the range of the tools. The more amperage your tool uses, the longer the

distance, the larger the size of the wire needed in your extension cord.

EYE PROTECTION – Goggles or spectacles intended to protect your eyes. Eye protection should meet the requirements of ANSI Z.87.1 (USA) or CSA Z94.3-M88 (Canada).

FACE SHIELD – An impact resistant shield that helps to protect your face from chips, sparks, small debris. Should only be used in conjunction with additional eye protection.

GLOSSARY OF TERMS

FENCE – (6, fig. F & G) Helps to keep the workpiece from moving when sawing. The sliding top half on each side can be moved out of the way at more extreme cutting angles.

GUARD – Protective device that forms a barrier between a hazardous object such as a blade, wheel or cutter and the operator. This saw has a static metal **upper blade guard** (7, fig. F & G) and swiveling clear plastic **lower blade guard** (8, fig. F & G).

HOLD-DOWN LATCH – (9, fig. G)

Locks the miter saw in the lowered position for compact storage and transportation.

INSTRUCTION OR OPERATOR'S

MANUAL – Booklet accompanying your power tool that describes the hazards and safe operation procedures, outlines basic tool operation, care and maintenance.

MITER HANDLE – (10, fig. F & G)

Used to rotate the table, and to rotate the saw to a right or left cutting position.

MITER SCALE – (11, fig. F & G)

Measures the miter angle of the saw blade. Positive stop index points have been provided at 0°, 15°, 22.5°, 31.6° and 45° right and left.

MOUNTING HOLES – (12, fig. F &

G) To mount the miter saw to a stable surface.

ON/OFF TRIGGER SWITCH – (13,

fig. F & G) To start the tool, squeeze the trigger. Release the trigger to turn off the miter saw.

POSITIVE STOP LOCKING LEVER–

(14, fig. F & G) Locks the miter saw at a preset positive stop for the desired miter angle.

SWITCH HANDLE – (15, fig. F & G)

The switch handle contains the trigger switch and the switch interlock (16, fig. F). The blade is lowered into the workpiece by pushing down on this handle. The saw will return to its upright position when the handle is released.

WARNING LABELS – Read and understand for your own safety. Make sure all labels are present on machine and legible.

LASER LINE GENERATOR – (18, fig. F & G)

DUST BAG – (19, fig. F & G)

HOLD-DOWN CLAMP – (20, fig. F & G)

WOODWORKING TERMS

ARBOR – The shaft on which a blade is mounted.

BEVEL CUT – An angle cut made through the face of the workpiece.

COMPOUND CUT – An angled cut to both the edge and face of a board, most common use is with crown molding.

CROSS CUT – A cut which runs across the board perpendicular to the grain.

FREEHAND – Performing a cut without using a fence (guide), hold down or other proper device to prevent the workpiece from twisting during the cutting operation.

GUM – A sticky sap from wood products.

HEEL – Misalignment of the blade.

KERF – The width of a saw cut, determined by the thickness and set of the blade.

KICKBACK – sudden and unintended movement of the tool or workpiece. It is typically caused by binding or pinching of the workpiece.

GLOSSARY OF TERMS

MITER CUT – A miter is a type of joint where the two parts to be joined are cut at an angle, and typically the finished joint forms a 90-degree angle. Also commonly spelled “mitre”.

RESIN – A sticky sap that has hardened.

REVOLUTIONS PER MINUTE (RPM) – The number of turns completed by a spinning object in one minute.

SAW BLADE PATH – The area of the workpiece or table top directly in line with the travel of the blade or the part of the workpiece which will be cut.

SET – The distance between two saw blade tips, bent outward in opposite directions to each other. The further apart the tips are, the greater the set.

THIN-KERF BLADE – Thinner than normal blades, remove less material, smaller kerfs (between 0.065 in. and 0.070 in.). Blade thinness also may increase the heat generated while cutting.

WORKPIECE – The wood being cut. The surfaces of a workpiece are commonly referred to as faces, ends and edges.

ASSEMBLY AND ADJUSTMENT

▲ WARNING

To avoid injury, do not connect this miter saw to the power source until it is completely assembled and adjusted and you have read and understood this Operator's Manual.

CUTTING HEAD (FIG. H)

▲ WARNING

To avoid injury and damage to the saw, transport and store the miter saw with the cutting head locked in the down position. Never use the stop latch to hold the cutting head in a down position for cutting operations.

RAISING

1. Push down slightly on the trigger switch handle (1).
2. Pull out the hold-down latch (2) out of the deep slot (5) of locking hole (3) and turn 90° to insert into the shallow slot (6).
3. Raise the cutting head to the uppermost position.

NOTE: This cutting head is spring loaded.

Fig. H

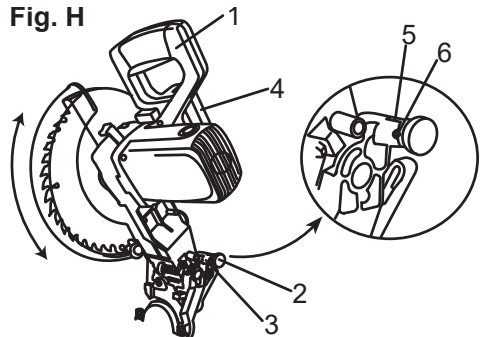

LOCKING

When transporting or storing the miter saw, the cutting head should always be locked in the down position.

1. Push the cutting head down.
2. Press the hold-down latch (2) in to lock.

IMPORTANT: To avoid damage, never carry the miter saw by the trigger switch handle or the cutting arm.

ASSEMBLY AND ADJUSTMENT

INSTALLING THE MITER HANDLE (FIG. I)

Fig. I

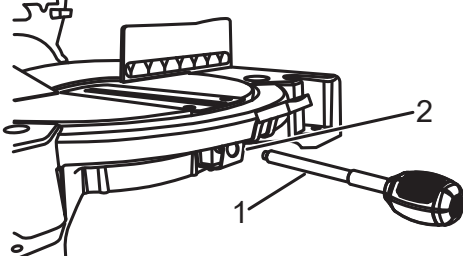

1. Thread the miter handle (1) into the hole (2) located at the front of the miter table.

INSTALLING THE DUST BAG (FIG. J)

1. Squeeze the metal collar wings (2) of the dust bag (1).

Fig. J

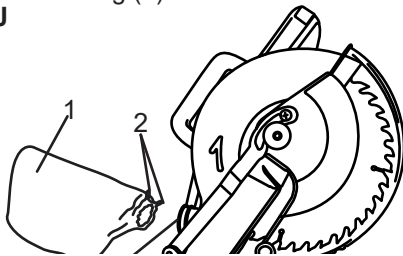

2. Place the dust bag neck opening around the exhaust port (3), and release the metal collar wings.

NOTE: To empty the dust bag, squeeze the metal collar and remove from exhaust port. Open zipper on underside of bag and empty into waste container.

INSTALLING THE REAR EXTENSION STAY (FIG. K)

1. Loosen the extension stay locking screw (1) under the saw base (2).
2. Place the rear extension stay (3) into

Fig. K

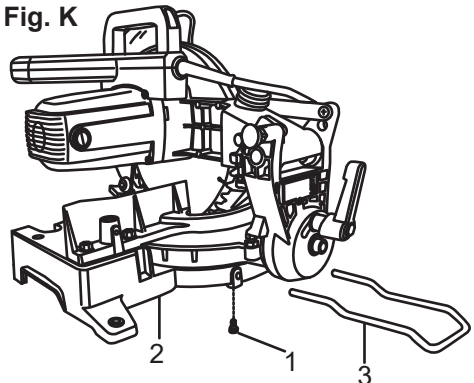

the holes provided in the miter saw base. Make sure the angle of stay is in the down position (as shown in Fig. K) for maximum support.

3. Insert the extension stay locking screw back to hole and tighten to hold the extension.

INSTALLING THE HOLD- DOWN CLAMP (FIG. L, L-1)

Fig. L

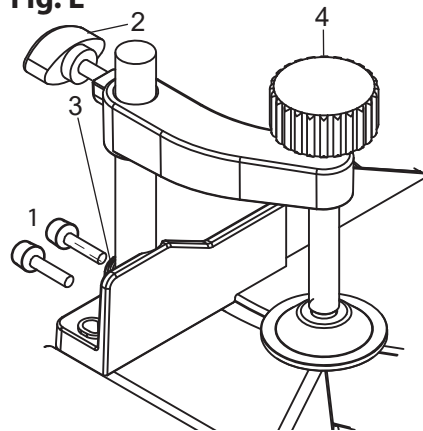

1. Loosen the lock knobs (1) from the rear side of the saw base.
2. Place the hold-down clamp assembly in one of the mounting holes (3).
3. Tighten the lock knobs (1).

ASSEMBLY AND ADJUSTMENT

Fig. L-1

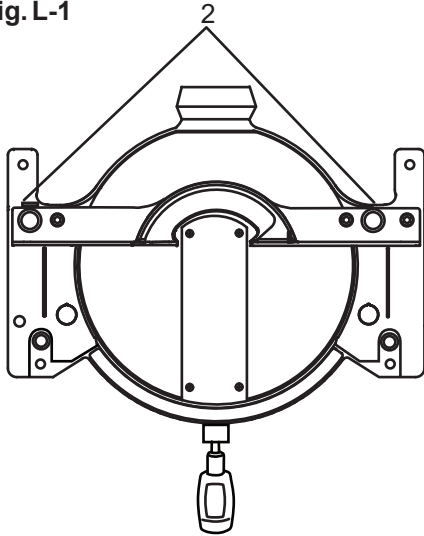

REMOVING AND INSTALLING THE BLADE

▲ WARNING

- To avoid injury from an accidental start, make sure the switch is in the OFF position and the plug is not connected to the power source outlet.
- Only use a 10 in. diameter blade.

NOTE: The miter saw comes with the saw blade already installed.

- **NEVER cut metals or masonry products with this tool. This miter saw is designed for use on wood and wood-like products only.**

REMOVING THE BLADE (FIG. M, N, O)

Before installing blade, cutting head must be raised and outer blade collar removed as in last step of blade removal procedure.

1. Unplug the saw from the outlet.

Fig. M

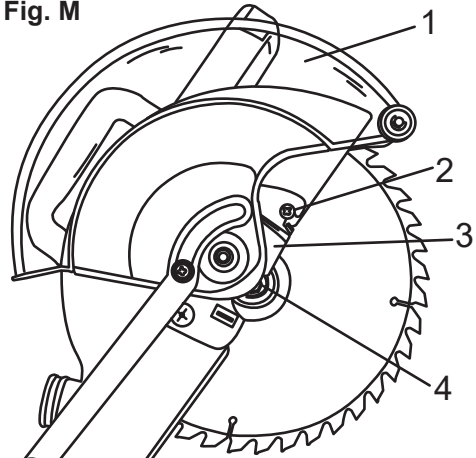

2. Allow the cutting head to rise to the upright position.
3. Raise the lower blade guard (1) to the up position. (Fig. M)
4. While holding the lower blade guard, loosen but do not remove the cover plate screw (2) with a Phillips screwdriver by turning the screw counterclockwise.
5. Rotate the cover plate (3) back to expose the arbor bolt (4).
6. Lower the cutting head and lock into place with the hold-down latch (8).
7. Place the blade wrench over the arbor bolt (4)

ASSEMBLY AND ADJUSTMENT

8. Locate the arbor lock (5) below motor lower cover. (Fig. N)

Fig. N

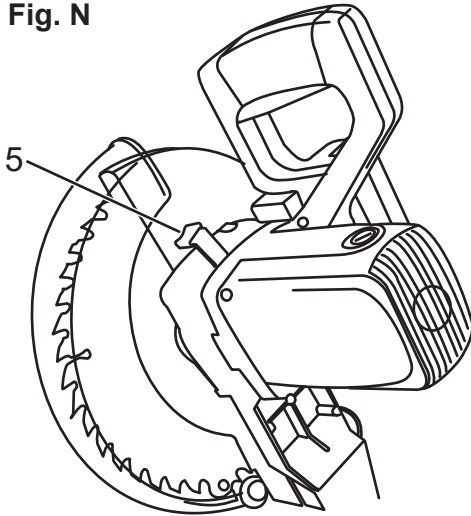

9. Press the arbor lock (5), holding it in firmly while turning the blade clockwise. At a certain point the arbor lock (5) will engage and lock the arbor. Continue to hold the arbor lock (5), while turning the wrench clockwise to loosen the arbor bolt (4, Fig. M).
10. Unlock cutting head and raise head to upright position
11. Remove the arbor bolt (4), the outer blade collar (6), and the blade (7). (Fig. O) Do not remove the inner blade collar.

NOTE: Pay attention to the pieces removed, noting their position and direction they face. Wipe the blade collars clean of any sawdust before installing a new blade.

INSTALLING THE BLADE (FIG. M, N, O)

▲ WARNING

Un-plug the miter saw before changing/installing the blade.

1. Install a 10 in. blade with a 5/8 in. arbor making sure the rotation arrow on the blade matches the clockwise rotation arrow on the upper guard, and the teeth on lower front of blade are pointing downward.

Fig. O

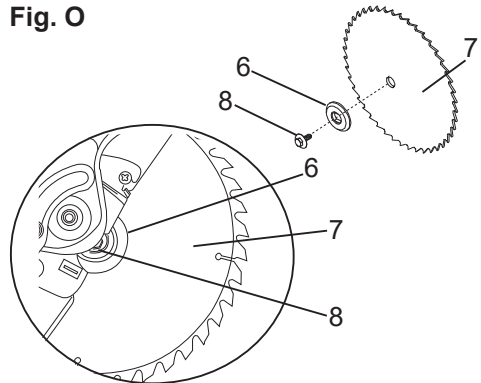

2. Place the blade onto the arbor. Place the outer blade collar (6) onto the arbor and against the blade. Thread the arbor bolt (8) counterclockwise onto the arbor. (Fig. O)

IMPORTANT: Make sure the flats of the blade collar openings are engaged with the flats of the arbor shafts. The collars must be flush against the blade.

3. Place the blade wrench on the arbor bolt (8). (Fig. O)

ASSEMBLY AND ADJUSTMENT

- Press the arbor lock (5), holding it in firmly while turning the blade counterclockwise. When it engages, continue to press the arbor lock (5) in, while tightening the arbor bolt (4, Fig. M) securely.
- Rotate the cover plate (3, Fig. M) back to its original position until the slot in the cover plate engages with the cover plate screw (2, Fig. M). While holding the lower blade guard, tighten the screw with a Phillips screwdriver.

NOTE: The lower blade guard must be raised to the upright position to access the cover plate screw.

- Lower the blade guard (1, Fig. M) and verify the operation of the guard does not bind or stick.

- Be sure the arbor lock (5, Fig. N) is released so the blade turns freely by spinning the blade until the arbor lock disengages.

▲ WARNING

- To avoid injury, never use the saw without the cover plate secure in place. It keeps the arbor bolt from falling out if it accidentally loosens, and helps prevent the spinning blade from coming off the saw.
- Make sure the collars are clean and properly arranged. Lower the blade into the table and check for any contact with the metal base or the saw table.

ADJUSTMENTS

ADJUSTING FENCE SQUARENESS (FIG. P)

- Lower the cutting arm and lock in position.

Fig. P

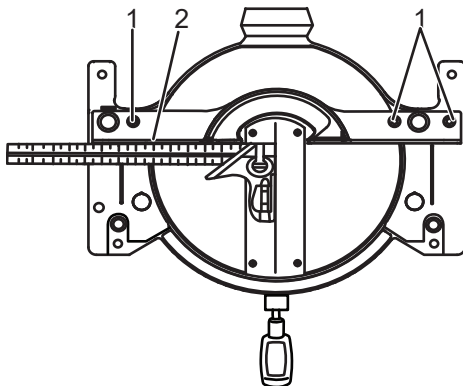

- Using a square (1), lay the heel of

the square against the blade and the ruler against the fence (2) as shown.

- Loosen the two fence locking bolts (3) with a 8 mm hex wrench.
- Adjust the fence 90° to the blade and tighten the two fence locking bolts.

CAUTION: If the saw has not been used recently, recheck blade squareness to the fence and readjust if needed.

- After fence has been aligned, using a scrap piece of wood, make a cut at 90°, then check squareness on the piece. Readjust if necessary.

MITER SCALE (FIG.Q)

The miter scale assists the user in setting the desired miter angles from 45° left to 45° right. The miter saw table has nine of the most common angle settings with

ADJUSTMENTS

positive stops at 0°, 15°, 22.5°, 31.6°, and 45°. These positive stops position the blade at the desired angle quickly and accurately.

To Adjust the Angle:

1. Unlock the miter table by turning the miter handle (1) counterclockwise.
2. Press down the positive stop locking lever (2) while holding the miter handle, and rotate the table left or right to the desired angle.
3. Release positive stop locking lever. Tighten miter handle.
4. If the desired angle is one of the nine positive stops, release the positive stop locking lever, making sure the lever snaps into position, and then secure by tightening the miter.
5. If the miter angle desired is not one of the nine positive stops, simply lock the miter table into position by turning the miter handle in the clockwise direction.

To Adjust the Indicator:

1. Adjust the indicator (3) to the 0° mark on the miter scale (4) to position the miter table.
2. Release positive stop locking lever (2). Tighten miter handle.

Fig. Q

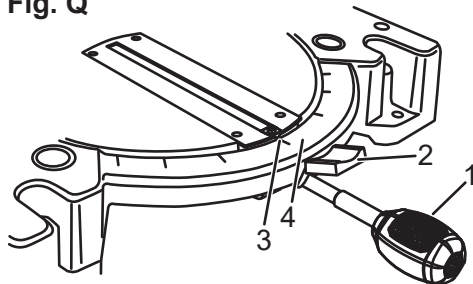

CUTTING ARM TRAVEL CUTTING ARM DOWNWARD TRAVEL ADJUSTMENT (FIG. R)

▲ WARNING

To avoid injury from unexpected starting or electrical shock, turn the switch OFF and remove the power cord from the power source.

NOTE: Before each cutting operation, check the position of the blade to make sure it does not contact any metal surface. If the blade contacts any metal surface, the depth of travel must be adjusted.

1. Lower the blade as far as possible.
2. Loosen the locknut (3).
3. Turn the adjustment bolt (4) out (counterclockwise) to decrease the cutting depth or in (clockwise) to increase the cutting depth.

Fig. R

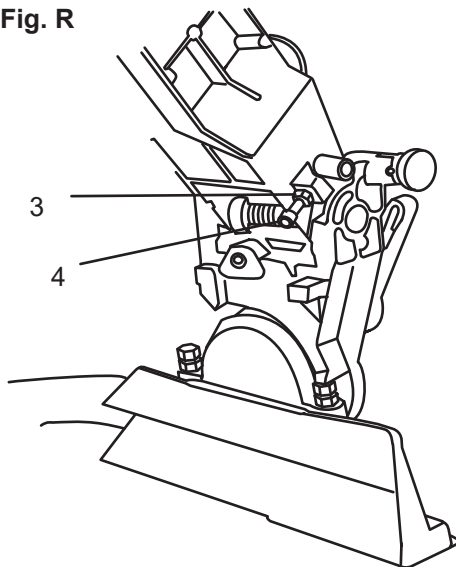

ADJUSTMENTS

- Carefully rotate the blade manually to check for contact. Avoid touching blade points or edges.
- Repeat until adjusted properly, and tighten the locknut to secure the adjustment bolt into position.

BEVEL STOP ADJUSTMENT (FIG. S, T, U)

▲ WARNING

To avoid injury from unexpected starting or electrical shock, turn the switch OFF and remove the power cord from the power source.

90° BEVEL ADJUSTMENT (FIG. S)

- Loosen bevel lock handle (1) and tilt the cutting arm completely to the right. Tighten the bevel lock handle. Lower blade.
- Place a combination square (2) on the miter table with the rule against the table and the heel of the square against the saw blade.
- If the blade is not 90° square with the miter table, loosen the bevel lock handle, tilt the cutting head completely to the left, loosen the locknut (4) on the bevel angle adjustment bolt (3) and use a 13 mm wrench to adjust the bolt (3) in or out to increase or decrease the bevel angle.
- Tilt the cutting arm to back to the right at 90° bevel and recheck for alignment.
- Repeat steps 1 through 4 if further adjustment is needed.
- Tighten bevel lock handle and locknut (4) when alignment is achieved.

Fig. S

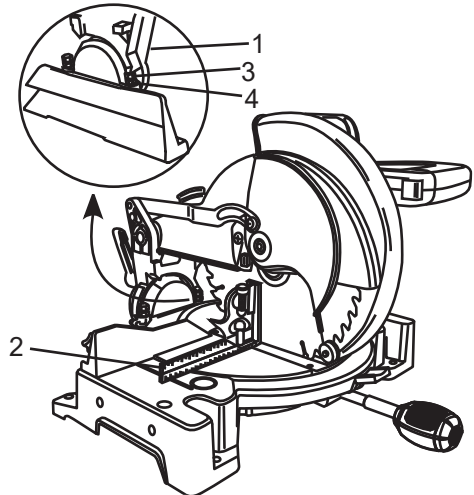

90° BEVEL INDICATOR (FIG. T)

- When the blade is exactly 90° to the table, loosen the bevel indicator screw (5) using a #2 Phillips screwdriver.

Fig. T

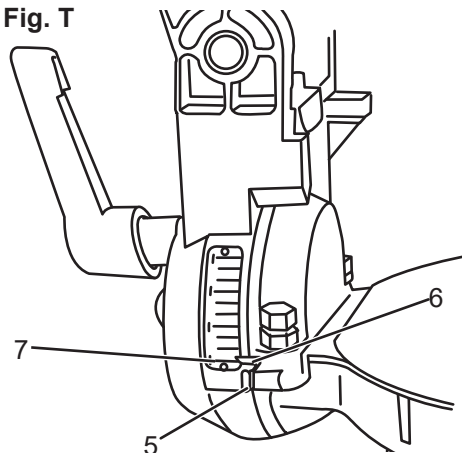

- Adjust bevel indicator (6) to the "0" mark (7) on the bevel scale and retighten the screw.

ADJUSTMENTS

45° BEVEL ADJUSTMENT (FIG. U)

1. Unlock the bevel lock handle (1) and tilt the cutting arm as far to the left as possible.

Fig. U

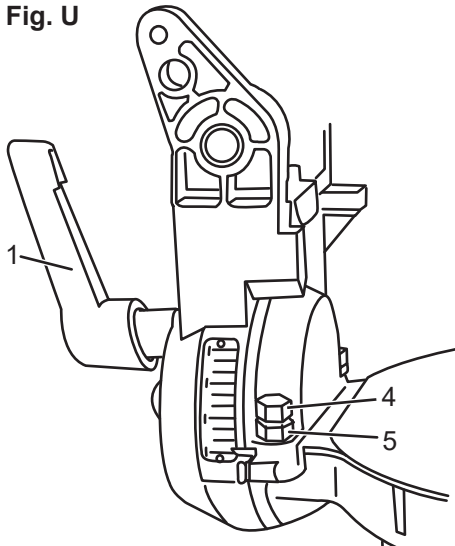

2. Using a combination square, check to see if the blade angle is 45° to the table.
3. If the blade is not at 45° to the miter table, tilt the cutting arm to the right, loosen the locknut (5) on the bevel angle adjustment bolt (4) and use a 13 mm wrench to adjust the bolt (4) in or out to increase or decrease the bevel angle.
4. Tilt the cutting arm to the left to 45° bevel and recheck for alignment.
5. Repeat steps 1 through 4 until the blade is at 45° to the miter table.
6. Tighten bevel lock handle and locknut (5) when alignment is achieved.

MOUNTING THE MITER SAW (FIG. V,W)

▲ WARNING

To avoid injury from unexpected saw movement:

- Before moving the miter saw, disconnect the power cord from the outlet, and lock the cutting arm in the lower position using the hold-down latch.

NOTE: The hold-down latch is for carrying or storing the tool. It is not to be used for holding the saw while cutting. Lower the cutting head and press in hold-down latch to secure the cutting head.

- Never carry the miter saw by the power cord or by the trigger switch handle. Carrying the tool by the power cord could cause damage to the insulation or wire connections and result in electric shock or fire.
- To avoid injury from flying debris, do not allow visitors to stand behind the saw.
- Place the saw on a firm, level workbench where there is room for handling and properly supporting the workpiece.
- Support the saw on a level work surface.
- Bolt or clamp the saw to its support.

MOUNTING

MOUNTING INSTRUCTIONS:

Place the saw in the desired location, either on a work bench or recommended leg set. The base of the saw has four mounting holes (10, Fig. V)

Fig. V

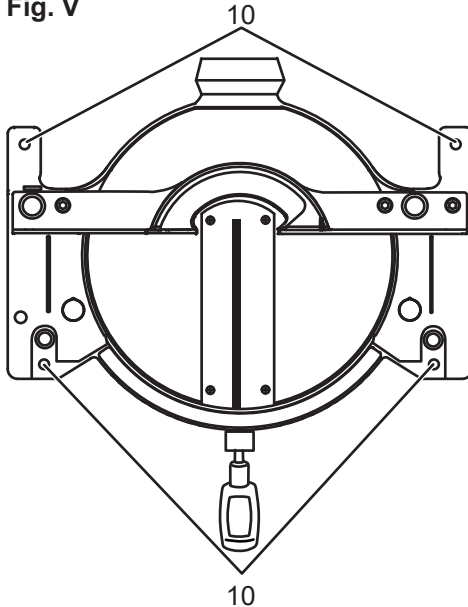

1. For stationary use, place the saw in the desired location, directly on a workbench where there is room for handling and proper support of the workpiece. The base of the saw has four mounting holes.
2. Bolt the base of the miter saw (1) to the work surface (5), using the fastening method as shown in Fig W.

NOTE: Mounting hardware is not included with this tool. Bolts, nuts, washers and screws must be purchased separately.

3. For portable use, place the miter saw

Fig. X

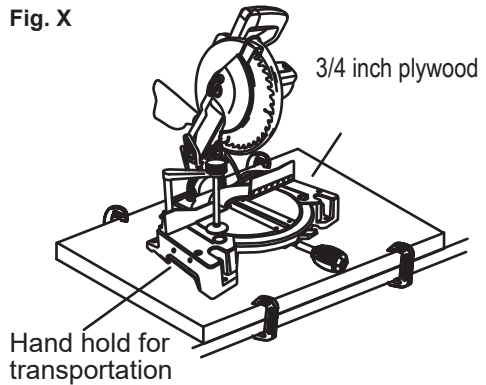

on a 3/4 in. thick piece of plywood. Bolt the base of the miter saw securely to the plywood using the mounting holes on the base. Use C-clamps to clamp this mounting board to a stable work surface at the worksite. (Fig. X)

NOTE: If a miter saw stand is used, please follow all instructions shown in that product's instructions for proper mounting.

LASER

The cutting head is equipped with a laser line to help ensure straight cutting by indicating the saw blade path on the workpiece. The laser line will appear just to the right side of the blade.

NOTE: The laser is powered when the saw is on.

AVOID DIRECT EYE CONTACT

▲ WARNING

- Laser radiated when Laser is turned on. Avoid direct eye contact.
- Laser Warning Label:
Max. Output < 5 mW
Wavelength: 630-660nm

LASER

Complies with 21 CFR 1040.10 and 1040.11.
Class IIIa Laser Product.

Fig. Z

Laser Aperture

Laser Warning Label

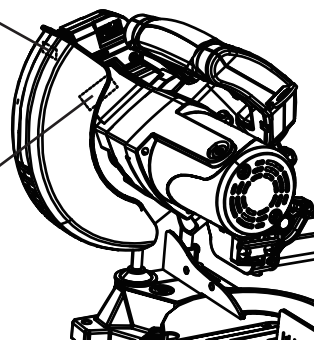

- **Laser Aperture Label: AVOID EXPOSURE:** Laser radiation is emitted from this aperture. (Fig. U)



- **NOTE:** The alignment of the laser line with the saw blade has been made at the factory and cannot be adjusted.
- **CAUTION:** Use of controls or adjustments or performance of procedures other than those specified herein may result in hazardous radiation exposure.
- **CAUTION:** The use of optical instruments with this product will increase eye hazard.
- **WARNING:** Do not attempt to repair or disassemble the laser. If unqualified persons attempt to repair this laser product, serious injury may result. Any repair required on this laser product should be performed by a qualified service dealer.

NOTE:

- Laser line is calibrated and set up to project to the left of the blade.
- If you have any problems or questions concerning the Laser, call the following numbers for assistance: USA toll-free (844) 877-5234 or (419) 877-5234 / Canada toll-free (888) 949-1161 or (604) 420-2299 or through our website: www.gipowerproducts.com.

OPERATION

SAFETY INSTRUCTIONS FOR BASIC SAW OPERATION BEFORE USING THE MITER SAW

▲ WARNING

To avoid mistakes that could cause serious, permanent injury, do not plug the tool in until the following steps are completed:

- Completely assemble and adjust the saw, following the instructions. (ASSEMBLY & ADJUSTMENTS)
- Learn the use and function of the ON/OFF trigger switch, on/off switch for laser, upper and lower blade guards, head hold-down latch, bevel lock handle, and cover plate screw.
- Review and understand all safety instructions and operating procedures in this Operator's Manual. (SAFETY & OPERATION)
- Review the MAINTENANCE and TROUBLESHOOTING GUIDE for your miter saw.
- To avoid injury or possible death from electrical shock: Make sure your fingers do not touch the plug's metal prongs when plugging or unplugging your miter saw. (ELECTRICAL REQUIREMENTS AND SAFETY)

BEFORE EACH USE, INSPECT YOUR SAW.

- **Disconnect the miter saw.** To avoid injury from accidental starting, unplug the saw before any adjustments, including set-up and blade changes.

- **Compare the direction of rotation arrow** on the guard to the direction arrow on the blade. The blade teeth should always point downward at the front of the saw.
- **Tighten the arbor bolt.**
- **Tighten the cover plate screw.**
- **Check for damaged parts.** Check for:
 - Alignment of moving parts
 - Damaged electric cords
 - Binding of moving parts
 - Mounting holes
 - Function of arm return spring and lower guard: Push the cutting arm all the way down, then let it rise until it stops. The lower guard should fully close. Follow instructions in TROUBLESHOOTING GUIDE for adjustment if necessary.
 - Other conditions that may affect the way the miter saw works.
- Keep all guards in place, in working order and proper adjustment. If any part of this miter saw is missing, bent, damaged or broken in any way, or any electrical parts don't work, turn the saw off and unplug it.
- Replace bent, damaged, missing or defective parts before using the saw again.
- Maintain tools with care. Keep the miter saw clean for best and safest performance. Follow instructions for lubricating. Do not put lubricants on the blade while it is spinning.
- Remove adjusting wrench from the tool before turning it on.

OPERATION

- To avoid injury from jams, slips, or thrown pieces, use only recommended accessories.
- Check the dust bag before you work. Empty the bag if it is more than half-full.

RECOMMENDED ACCESSORIES

- Consult the ACCESSORIES and ATTACHMENTS section of this Operator's Manual for recommended accessories. Follow the instructions that come with the accessory. The use of improper accessories may cause risk of injury to persons.
- Choose the correct 10 in. diameter blade for the material and the type of cutting you plan to do.
- Make sure the blade is sharp, undamaged and properly aligned. With the saw unplugged, push the cutting arm all the way down. Manually spin the blade and check for clearance. Tilt the power-head to a 45° bevel and repeat the test.
- Make sure the blade and arbor collars are clean.
- Make sure all clamps and locks are tight and there is no excessive play in any parts.

KEEP YOUR WORK AREA CLEAN

Cluttered areas and benches invite accidents.

WARNING

To avoid burns or other fire damage, never use the miter saw near flammable liquids, vapors, or gases.

- Plan ahead to protect your eyes, hands, face and ears.
- Know your miter saw. Read and

understand this Operator's Manual and labels affixed to this tool. Learn its application and limitations as well as the specific potential hazards peculiar to this tool. To avoid injury from accidental contact with moving parts, do not do layout, assembly, or setup work on the miter saw while any parts are moving.

- Avoid accidental starting, make sure the trigger switch is disengaged before plugging the miter saw into a power outlet.

PLAN YOUR WORK

- Use the right tool. Don't force a tool or attachment to do a job it was not designed to do. Use a different tool for any workpiece that can't be held in a solidly braced, fixed position.

CAUTION

This machine is not designed for cutting masonry, masonry products, ferrous metals (steel, iron, and ironbased metals.) Use this miter saw to cut only wood, wood-like products, or non-ferrous metals. Other material may shatter, bind the blade, or create other dangers. Remove all nails that may be in the workpiece to prevent sparking that could cause a fire. Remove dust bag when cutting nonferrous metals.

DRESS FOR SAFETY



Any power tool can throw foreign objects into the eyes. This can result in permanent eye damage. Everyday eyeglasses have only impact resistant lenses and are not safety glasses. Glasses or goggles not in compliance with ANSI Z87.1 could seriously injure you when they break.

- Do not wear loose clothing, gloves,

OPERATION

neckties or jewelry (rings, watches). They can get caught and draw you into moving parts.

- Wear non-slip footwear.
- Tie back long hair.
- Roll long sleeves above the elbow.
- Noise levels vary widely. To avoid possible hearing damage, wear ear plugs when using any miter saw.
- For dusty operations, wear a dust mask along with safety goggles.

INSPECT YOUR WORKPIECE

- Make sure there are no nails or foreign objects in the part of the workpiece being cut.
- Plan your work to avoid small pieces that may bind or are too small to clamp and hold securely.
- Plan the way you will grasp the workpiece from start to finish. Avoid awkward operations and hand positions. A sudden slip could cause your fingers or hand to move into the blade.

DO NOT OVER-REACH

Keep good footing and balance. Keep your face and body to one side, out of the line of a possible kickback. NEVER stand in the line of the blade.

Never cut freehand:

- Brace your workpiece firmly against the fence and table stop so it will not rock or twist during the cut.
- Make sure there is no debris between the workpiece and the table or fence.
- Make sure there are no gaps between the workpiece, fence and

table that will let the workpiece shift after it is cut.

- Keep the cut off piece free to move sideways after it is cut off. Otherwise, it could get wedged against the blade and thrown violently.
- Only the workpiece should be on the saw table.
- Secure work. Use clamps or a vice to help hold the work when it's practical.

USE EXTRA CAUTION WITH LARGE OR ODD-SHAPED WORKPIECES.

- Use extra supports (tables, sawhorses, blocks, etc.) for workpieces large enough to tip.
- Never use another person as a substitute for a table extension, or as an additional support for a workpiece that is longer or wider than the basic miter saw table, or to help feed, support, or pull the workpiece.
- Do not use this saw to cut small pieces. If the workpiece being cut would cause your hand or fingers to be within 6-3/4 in. of the saw blade the workpiece is too small. Keep hands and fingers out of the "no hands zone" area marked on the saw table.
- When cutting odd shaped workpieces, plan your work so it will not bind in the blade and cause possible injury. Molding, for example, must lie flat or be held by a fixture or jig that will not let it move when cut.
- Properly support round material such as dowel rods, or tubing, which have a tendency to roll when cut, causing the blade to "bite".

OPERATION

▲ WARNING

To avoid injury, follow all applicable safety instructions, when cutting non-ferrous metals:

- Use only saw blades specifically recommended for non-ferrous metal cutting.
- Do not cut metal workpieces that must be hand held. Clamp workpieces securely.
- Cut non-ferrous metals only if you are under the supervision of an experienced person and the dust bag has been removed from the saw.

WHEN SAW IS RUNNING

▲ WARNING

Do not allow familiarity from frequent use of your miter saw to result in a careless mistake. A careless fraction of a second is enough to cause a severe injury.

Before cutting, if the saw makes an unfamiliar noise or vibrates, stop immediately. Turn the saw OFF. Unplug the saw. Do not restart until finding and correcting the problem.

MAKING A BASIC CUT

▲ WARNING

BODY AND HAND POSITION (FIG. AA)



Never place hands near the cutting area. Proper positioning of your body and hands when operating the miter saw will make cutting easier and safer. Keep children away. Keep all visitors at a safe distance from the miter saw. Make sure bystanders are clear of the saw and workpiece. Don't force the saw.

It will do the job better and safer at its designed rate.

STARTING A CUT:

- Place hands at least 6-3/4 in. away on both sides of the blade path - "no-hands zone". (Fig. AA)

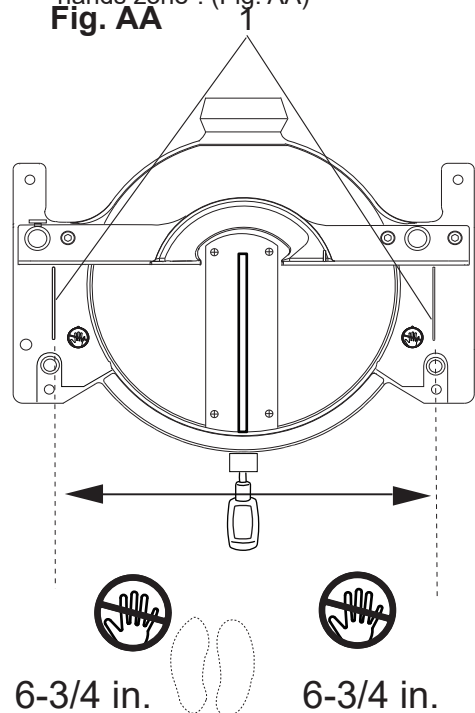

- Hold workpiece firmly against the fence to prevent movement toward the blade.
- Turn the Laser on for prealignment of your cut.
- With the power switch OFF, bring the saw blade down to the workpiece to see the cutting path of the blade.
- Squeeze trigger switch to start saw.
- Lower blade into workpiece with a firm downward motion.

OPERATION

- On wider boards slide the cutting arm back toward fence to make the cut.

FINISHING A CUT:

- Hold the cutting arm in the down position.
- Release trigger switch and wait for all moving parts to stop before moving your hands and raising the cutting arm.
- If the blade does not stop within 10 seconds, unplug the saw and follow the instructions in TROUBLESHOOTING GUIDE section.

BEFORE FREING JAMMED MATERIAL:

- Release trigger switch.
- Wait for all moving parts to stop.
- Unplug the miter saw.

BASIC SAW OPERATIONS

▲ WARNING

For your convenience, your saw has a blade brake. The brake is not a safety device. Never rely on it to replace the proper use of the guard on your saw. If the blade doesn't stop within approximately 10 seconds, wait for the blade to stop, unplug the saw and contact General International or another qualified service dealer.

TURNING THE SAW ON (FIG. BB)

Depress the trigger interlock (1) and then the trigger switch (2) to turn on the miter saw.

NOTE: The miter saw is equipped with an electric blade brake. When the trigger switch is released, the blade brake will stop the blade within approximately 10 seconds.

NOTE: To make the ON/OFF switch childproof. Insert a padlock (not provided) or chain with padlock through the hole (3) in the trigger switch. Lock the tool's switch to prevent children and other unqualified users from turning the machine on.

Fig. BB

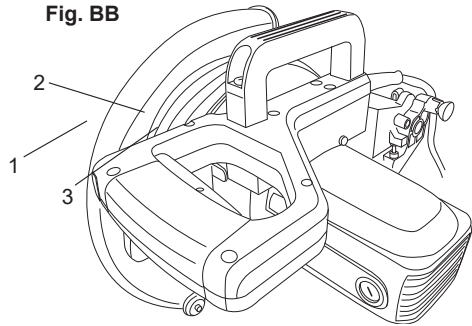

BEFORE LEAVING THE SAW

- Never leave tool running unattended. Turn power OFF. Wait for all moving parts to stop.
- Make workshop childproof. Lock the shop. Disconnect master switches. Store tool away from children and other unqualified users.

▲ WARNING

To avoid injury from materials being thrown, always unplug the saw to avoid accidental starting, and remove small pieces of material from the table cavity. The table insert may be removed for this purpose, but always reattach the table insert prior to performing a cutting operation.

MITER CUT (FIG. CC)

1. When a miter cut is required, unlock the miter table by turning the miter handle (1) anti-clockwise.
2. While holding the miter handle, lift up

OPERATION

on the positive stop lock lever (2).

3. Rotate the miter table to the right or left as shown in Fig. CC

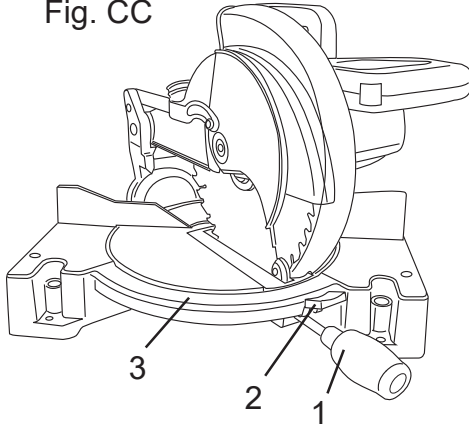

left with the miter handle (1).

4. When the table is in the desired position, as shown on the miter scale (3), release the positive stop lock lever (2) and tighten the miter handle (1). The table is now locked at the desired angle. Positive stops are provided at 0°, 15°, 22.5°, 31.6° and 45°.

IMPORTANT: Always tighten the miter table lock handle before performing every cutting operation.

5. Use the Laser and position the workpiece on the table for prealignment of your cut.

BEVEL CUT (FIG. DD)

1. When a bevel cut is required, loosen the bevel lock handle (1) by turning it clockwise.
2. Tilt the cutting head to the desired angle, as shown on the bevel scale (2).

3. The blade can be positioned at any angle, from a 90° straight cut (0° on the scale) to a 47° left bevel. Tighten

Fig. DD

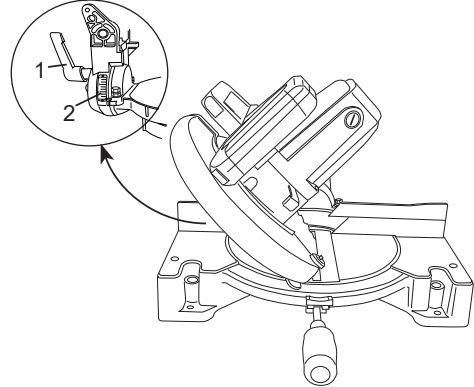

the bevel lock handle (1) to lock the cutting head in position. Positive stops are provided at 0° and 45°.

4. Turn the Laser on and position the workpiece on the table for prealignment of your cut.

COMPOUND CUT (FIG. DD, EE)

A compound cut is the combination of a miter and a bevel cut simultaneously.

1. Loosen the bevel lock handle (1) and position the cutting head at the desired bevel position. Lock the bevel lock handle (1). (Fig. DD)
2. Loosen the miter handle (3). Lift up the positive stop lock lever (4) and position the table at the desired angle. Release the positive stop lock lever (4) and lock the miter handle (3). (Fig. EE)

OPERATION

Fig.EE

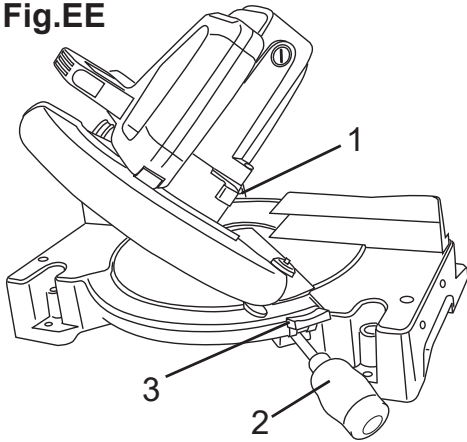

3. Release the trigger and allow the blade to stop spinning before allowing the cutting head to raise.

CUTTING BOWED MATERIAL (FIG. FF)

▲ WARNING

To avoid injury from materials being thrown, always unplug the saw to avoid accidental starting and remove small pieces of material from the table cavity.

Fig. FF

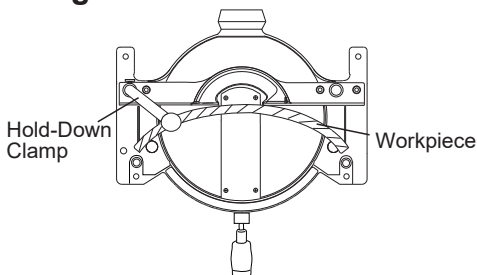

The table insert may be removed for this purpose, but always re-attach table insert prior to performing a cutting operation.

A bowed workpiece must be positioned against the fence and secured with a hold-down clamp as shown before

cutting. Do not position workpiece incorrectly or try to cut the workpiece without the support of the fence. This will cause the blade to bind and could result in personal injury.

CUTTING BASE MOLDING (FIG. GG)

Base moldings and many other moldings can be cut on a compound miter saw. The setup of the saw depends on molding characteristics and application, as shown. Perform practice cuts on scrap material to achieve best results:

1. Always make sure moldings rest firmly against fence and table. Use hold-down, crown molding vise or C-clamps, whenever possible, and place tape on the area being clamped to avoid marks.

Fig. GG

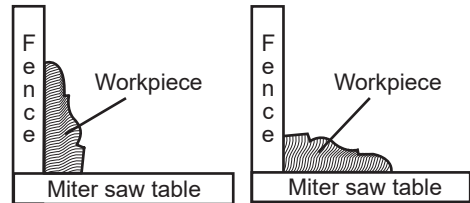

miter at 45°, bevel at 0° miter at 0°, bevel at 45°

2. Reduce splintering by taping the cut area prior to making the cut. Mark the cut line directly on the tape.
3. Splintering typically happens due to an incorrect blade application and thinness of the material.

NOTE: Always perform a dry run cut so you can determine if the operation being attempted is possible before power is applied to the saw.

OPERATION

CUTTING CROWN MOLDING (FIG. HH, II)

Your compound miter saw is suited for the difficult task of cutting crown molding. To fit properly, crown molding must be compound-mitered with extreme accuracy. The two surfaces on a piece of crown molding that fit flat against the ceiling and wall are at angles that, when added together, equal exactly 90°.

Most crown molding has a top rear angle (the section that fits flat against the ceiling) of 52° and a bottom rear angle (the section that fits flat against the wall) of 38°.

In order to accurately cut crown molding for a 90° inside or outside corner, lay the molding with its broad back surface flat on the saw table.

Fig. HH

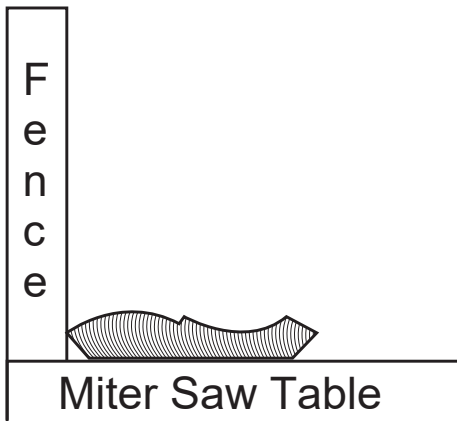

When setting the bevel and miter angles for compound miters, remember that the settings are interdependent; changing one changes the other, as well.

OPERATION

CROWN MOLDING BEVEL/ MITER SETTINGS

Fig. II

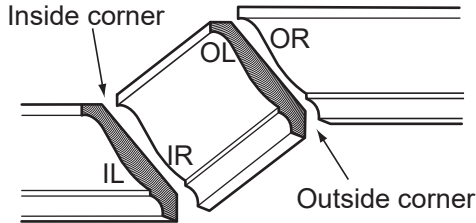

Compound cut crown moldings

Settings for standard crown molding lying flat on compound miter saw table:

NOTE: The chart below references a compound cut for crown molding **ONLY** WHEN THE ANGLE BETWEEN THE WALLS EQUALS 90°.

KEY see Fig. JJ	BEVEL SETTING	MITER SETTING	TYPE OF CUT
Inside corner-Left side			
IL	33.9°	31.6° Right	1. Position top of molding against fence. 2. Miter table set at RIGHT 31.6°. 3. LEFT side is finished piece.
Inside corner-Right side			
IR	33.9°	31.6° Left	1. Position bottom of molding against fence. 2. Miter table set at LEFT 31.6°. 3. LEFT side is finished piece.
Outside corner-Left side			
OL	33.9°	31.6° Left	1. Position bottom of molding against fence. 2. Miter table set at LEFT 31.6°. 3. RIGHT side is finished piece.
Outside corner-Right side			
OR	33.9°	31.6° Right	1. Position top of molding against fence. 2. Miter table set at RIGHT 31.6°. 3. RIGHT side is finished piece.

CROWN MOLDING CHART

COMPOUND MITER SAW MITER AND BEVEL ANGLE SETTINGS WALL TO CROWN MOLDING ANGLE

Angle Between Walls	52/38° Crown Molding		45/45° Crown Molding	
	Miter Setting	Bevel Setting	Miter Setting	Bevel Setting
67	42.93	41.08	46.89	36.13
68	42.39	40.79	46.35	35.89
69	41.85	40.50	45.81	35.64
70	41.32	40.20	45.28	35.40
71	40.79	39.90	44.75	35.15
72	40.28	39.61	44.22	34.89
73	39.76	39.30	43.70	34.64
74	39.25	39.00	43.18	35.38
75	38.74	38.69	42.66	34.12
76	38.24	38.39	42.15	33.86
77	37.74	38.08	41.64	33.60
78	37.24	37.76	41.13	33.33
79	36.75	37.45	40.62	33.07
80	36.27	37.13	40.12	32.80
81	35.79	36.81	39.62	32.53
82	35.31	36.49	39.13	32.25
83	34.83	36.17	38.63	31.98
84	34.36	35.85	38.14	31.70
85	33.90	35.52	37.66	31.42
86	33.43	35.19	37.17	31.14
87	32.97	34.86	36.69	30.86
88	32.52	34.53	36.21	30.57
89	32.07	34.20	35.74	30.29
90	31.62	33.86	35.26	30.00
91	31.17	33.53	34.79	29.71
92	30.73	33.19	34.33	29.42
93	30.30	32.86	33.86	29.13
94	29.86	32.51	33.40	28.83
95	29.43	32.17	32.94	28.54
96	29.00	31.82	32.48	28.24
97	28.58	31.48	32.02	27.94
98	28.16	31.13	31.58	27.64
99	27.74	30.78	31.13	27.34
100	27.32	30.43	30.68	27.03
101	26.91	30.08	30.24	26.73
102	26.50	29.73	29.80	26.42
103	26.09	29.38	29.36	26.12
104	25.69	29.02	28.92	25.81
105	25.29	28.67	28.48	25.50
106	24.89	28.31	28.05	25.19
107	24.49	27.96	27.62	24.87
108	24.10	27.59	27.19	24.56
109	23.71	27.23	26.77	24.24
110	23.32	26.87	26.34	23.93
111	22.93	26.51	25.92	23.61
112	22.55	26.15	25.50	23.29
113	22.17	25.78	25.08	22.97
114	21.79	25.42	24.66	22.66
115	21.42	25.05	24.25	22.33
116	21.04	24.68	23.84	22.01
117	20.67	24.31	23.43	21.68
118	20.30	23.94	23.02	21.36
119	19.93	23.57	22.61	21.03
120	19.57	23.20	22.21	20.70
121	19.20	22.83	21.80	20.38
122	18.84	22.46	21.40	20.05
123	18.48	22.09	21.00	19.72

Angle Between Walls	52/38° Crown Molding		45/45° Crown Molding	
	Miter Setting	Bevel Setting	Miter Setting	Bevel Setting
124	18.13	21.71	20.61	19.39
125	17.77	21.34	20.21	19.06
126	17.42	20.96	19.81	18.72
127	17.06	20.59	19.42	18.39
128	16.71	20.21	19.03	18.06
129	16.37	19.83	18.64	17.72
130	16.02	19.45	18.25	17.39
131	15.67	19.07	17.86	17.05
132	15.33	18.69	17.48	16.71
133	14.99	18.31	17.09	16.38
134	14.66	17.93	16.71	16.04
135	14.30	17.55	16.32	15.70
136	13.97	17.17	15.94	15.36
137	13.63	16.79	15.56	15.02
138	13.30	16.40	15.19	14.62
139	12.96	16.02	14.81	14.34
140	12.63	15.64	14.43	14.00
141	12.30	15.25	14.06	13.65
142	11.97	14.87	13.68	13.31
143	11.64	14.48	13.31	12.97
144	11.31	14.09	12.94	12.62
145	10.99	13.71	12.57	12.29
146	10.66	13.32	12.20	11.93
147	10.34	12.93	11.83	11.59
148	10.01	12.54	11.46	11.24
149	9.69	12.16	11.09	10.89
150	9.37	11.77	10.73	10.55
151	9.05	11.38	10.36	10.20
152	8.73	10.99	10.00	9.85
153	8.41	10.60	9.63	9.50
154	8.09	10.21	9.27	9.15
155	7.77	9.82	8.91	8.80
156	7.46	9.43	8.55	8.45
157	7.14	9.04	8.19	8.10
158	6.82	8.65	7.83	7.75
159	6.51	8.26	7.47	7.40
160	6.20	7.86	7.11	7.05
161	5.88	7.47	6.75	6.70
162	5.57	7.08	6.39	6.35
163	5.26	6.69	6.03	6.00
164	4.95	6.30	5.68	5.65
165	4.63	5.90	5.32	5.30
166	4.32	5.51	4.96	4.94
167	4.01	5.12	4.61	4.59
168	3.70	4.72	4.25	4.24
169	3.39	4.33	3.90	3.89
170	3.08	3.94	3.54	3.53
171	2.77	3.54	3.19	3.10
172	2.47	3.15	2.83	2.83
173	2.15	2.75	2.48	2.47
174	1.85	2.36	2.12	2.12
175	1.54	1.97	1.77	1.77
176	1.23	1.58	1.41	1.41
177	0.92	1.18	1.06	1.06
178	0.62	0.79	0.71	0.71
179	0.31	0.39	0.35	0.35

MAINTENANCE

▲ DANGER

To avoid injury, never put lubricants on the blade while it is spinning.

▲ WARNING

- To avoid fire or toxic reaction, never use gasoline, naphtha acetone, lacquer thinner or similar highly volatile solvents to clean the miter saw.
- To avoid injury from unexpected starting or electrical shock, unplug the power cord before working on the saw.
- To avoid electrical shock, fire or injury, use only parts identical to those identified in the parts list. Reassemble exactly as the original assembly to avoid electrical shock.

REPLACING CARBON BRUSHES (FIG. JJ)

The carbon brushes furnished will last approximately 50 hours of running time, or 10,000 ON/OFF cycles. Replace both carbon brushes when either has less than 1/4 in. length of carbon remaining, or if the spring or wire is damaged or burned. To inspect or replace brushes, first unplug the saw. Then remove the black plastic cap (1) on the side of the motor (2). Remove the cap cautiously, because it is springloaded. Then pull out the brush (3) and replace. Replace for the other side. To reassemble reverse the procedure. The ears on the metal end of the assembly go in the same hole the carbon part fits into. Tighten the cap snugly, but do not overtighten.

NOTE: To reinstall the same brushes, first make sure the brushes go back in the way they came out. This will avoid a break-in period that reduces motor performance and increases wear.

Fig. JJ

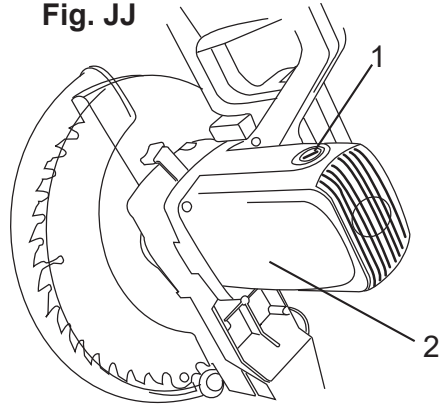

LOWER BLADE GUARD

Do not use the saw without the lower blade guard. The lower blade guard is attached to the saw for your protection. Should the lower guard become damaged, do not use the saw until the damaged guard has been replaced. Develop a regular check to make sure the lower guard is working properly. Clean the lower guard of any dust or buildup with a damp cloth.

▲ WARNING

- When cleaning the lower guard, unplug the saw from the power source receptacle to avoid unexpected startup.
- Do not use solvents on the guard. They could make the plastic “cloudy” and brittle.

EMPTYING SAWDUST BAG

Periodically, sawdust will accumulate under the work table and base. This could cause difficulty in the movement of the worktable when setting up a miter cut.

MAINTENANCE

Frequently blow out or vacuum up the sawdust.

▲ WARNING

Wear proper eye protection to keep debris from entering eyes when removing sawdust from unit.

LUBRICATION

(FIG. KK)

Fig. KK

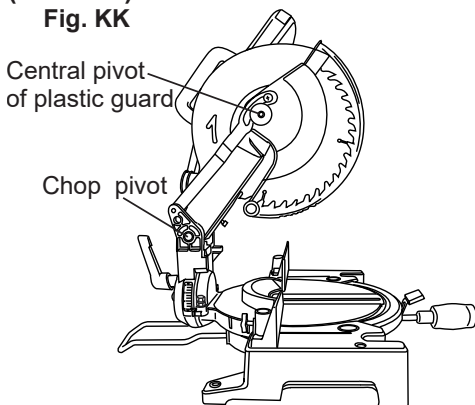

All the motor bearings in this tool are lubricated with a sufficient amount of high grade lubricant for the life of the unit under normal operating conditions; therefore, no further lubrication is required.

Lubricate the following as necessary:

CHOP PIVOT: Apply light machine oil to points indicated in illustration.

CENTRAL PIVOT OF PLASTIC

GUARD: Use light household oil (sewing machine oil) on metal-to-metal or metal-to plastic guard contact areas as required for smooth, quiet operation. Avoid excessive oil, to which sawdust will cling.

GUIDE

▲ WARNING

To avoid injury from accidental starting, always turn switch OFF and unplug the tool before moving, replacing the blade or making adjustments.

TROUBLESHOOTING GUIDE - MOTOR

PROBLEM	PROBLEM CAUSE	SUGGESTED CORRECTIVE ACTION
Brake does not stop the blade within 6 seconds.	<ol style="list-style-type: none"> 1. Motor brushes not sealed or lightly sticking. 2. Motor brake overheated from use of defective or wrong size blade or rapid ON/OFF cycling. 3. Arbor bolt loose. 4. Brushes cracked, damaged, etc. 5. Other. 	<ol style="list-style-type: none"> 1. Inspect/clean/replace brushes. See MAINTENANCE section. 2. Use a recommended blade. Let cool down. See REMOVING OR INSTALLING THE BLADE section. 3. Retighten. See REMOVING OR INSTALLING THE BLADE section. 4. Replace brushes. 5. Contact General International Service.
Motor does not start	<ol style="list-style-type: none"> 1. Limit switch failure 2. Brush worn. 3. Fuse blown or circuit breaker tripped on home panel. 	<ol style="list-style-type: none"> 1. Replace limit switch. 2. Replace brushes. See MAINTENANCE section. 3. Verify there is electrical power at the outlet.
Brush spark when switch released.	<ol style="list-style-type: none"> 1. Brush worn. 2. Other. 	<ol style="list-style-type: none"> 1. Replace Brushes. See MAINTENANCE section. 2. Contact General International Service.

TROUBLESHOOTING GUIDE - SAW OPERATION

PROBLEM	PROBLEM CAUSE	SUGGESTED CORRECTIVE ACTION
Blade hits table.	<ol style="list-style-type: none"> 1. Misalignment. 	<ol style="list-style-type: none"> 1. See ADJUSTMENT - Cutting Head Downward Travel Adjustment section.
Angle of cut not accurate. Cannot adjust miter.	<ol style="list-style-type: none"> 1. Miter table unlocked. 	<ol style="list-style-type: none"> 1. See OPERATION - Miter Angle Adjustment section.
	<ol style="list-style-type: none"> 2. Sawdust under table. 	<ol style="list-style-type: none"> 2. Vacuum or blow out dust. WEAR EYE PROTECTION.
Cutting arm wobbles.	<ol style="list-style-type: none"> 1. Loose pivot points. 	<ol style="list-style-type: none"> 1. Contact General International Service.

TROUBLESHOOTING GUIDE

▲ WARNING

To avoid injury from accidental starting, always turn switch OFF and unplug the tool before moving, replacing the blade or making adjustments.

TROUBLESHOOTING GUIDE - SAW OPERATION

PROBLEM	PROBLEM CAUSE	SUGGESTED CORRECTIVE ACTION
Cutting arm will not fully raise, or blade guard won't fully close.	1. Pivot bolt too tight.	1. Loosen pivot bolt lock nut (see adjustment section).
	2. Pivot spring not replaced properly after service.	2. Contact General International Service.
	3. Sawdust build-up.	3. Clean and lubricate moving parts.
Blade binds, jams, burns wood.	1. Improper operation.	1. See BASIC SAW OPERATION section.
	2. Dull or warped blade.	2. Replace or sharpen blade.
	3. Improper blade size.	3. Replace with 10 in. diameter blade.
	4. Wood is moving during cut.	4. Use hold down clamp to secure workpiece to table.
Saw vibrates or shakes.	1. Saw blade not round / damaged / loose.	1. Replace blade.
	2. Arbor bolt loose.	2. Tighten arbor bolt.

PARTS LIST

To purchase parts, call 844.877.5234 in the U.S. or Canada call toll free 888.949.1161

Ref.	Description	Qty.
2	M8 x 16 outer hexagon screw	4
3	Base	1
4	M6 x 15 small knob	1
5	Turntable steel sheet	3
6	M5 x 12 phillips pan head screw	3
7	M5 spring washer	7
8	M4 flat washer	3
9	2.5 x 4 rivet (white)	2 1
10	Turntable handle	1
11	Crossbar	1
12	M8 flat washer	3
13	M8 spring washer	3
14	M6 x 32 small handwheel	4
15	M6 x 18 phillips flat head screw	1
16	Anti-tip support	1
17	Clamp pressure plate	1
18	Clamping locating rod	1
19	Connecting rod	1
20	Handle	1
21	Chamfer-cut pointer	1
22	M4 spring washer	
23	M4 x 10 phillips pan head screw	1
24	Bracket	1 1
25	Turntable pointer	
26	Bevel scale	1
27	M10 big spring washer	2
28	Pin nut	1
29	Bracket locking handle	1
30	Locking spring	1
31	Pin cover	1
32	M10 latch nut	1
33	Turntable spring steel sheet sheath	1
34	Spring steel	1
35	Turntable	1

Ref.	Description	Qty.
36	M4 x 8 phillips countersunk head screw	3
37	Insert	1
38	M8 flat washer	1
39	M8 lock nut	1
40	M8 nut	2
41	M8 x 20 outer hexagon screw	2
42	M5 x 8 phillips pan head screw	1
43	M10 x 55 double head stud	1
44	Large torsion spring	1
45	Hood pin	1
46	Hollow pin	1
47	Hood self-locking pin	1
48	Self-locking spring	1
49	Self-locking cap	1
50	Double offset ring spanner	1
51	M8 x 20 left hexagon flange bolt	1
52	Pressure pad	2
53	Sawblade	1
54	Switching push-button	1
56	Output shaft	1
57	4 woodruff key	1
58	M5 x 16 phillips pan head screw	2
59	Bearing gland	1
60	6203 bearing	1
61	Bearing housing	1
62	Big gear	1
63	Needle bearing	1
64	0.17 jump ring for shaft	1
65	Connecting rod non-standard screw	1
66	Connecting rod	1
67	M6 x 25 socket head cap screw	1
68	M6 nut	1
69	Limited post	1
70	Stop screw	1

PARTS LIST

Ref.	Description	Qty.
71	Dust collection bag sub-assembly	1
72	.5E jump ring	2
73	Stator	1
74	M5 x 65 phillips pan head tapping screw	2
75	Baffle	1
76	Carbon brush	2
77	Label 1	1
78	Label 2	1
79	Label 7	1
80	Tension rod sheath	1
81	Rubber plug	1
82	M6 flat washer	3
83	Connecting rod pulley	1
84	M6 x 152 phillips pan head screw	1
85	M6 lock nut	1
86	Transparent cover gasket (small)	1
87	Large cover	1
88	Transparent cover	1
89	Transparent cover gasket (large)	1
90	Rubber stop	1
91	M6 x 7 large flat head phillips non-standard screw	1
92	M5 flat head phillips tapping locking screw	4
93	M4.2 toothed washer (White)	1
94	Transparent cover coil spring	1
95	M6 x 110 phillips pan head screw	1
96	M6 flat washer	5
97	Transparent cover spring plate	1
98	Hood	1
99	6202 bearing	1
100	Self-locking tension rod	1
101	Self-locking compression spring	1
102	Rotor	1

Ref.	Description	Qty.
103	Phosphor copper spring	2
104	6000 bearing	1
105	Housing case	1
106	M6 x 135 phillips pan head screw	4
107	M5 x 140 phillips pan head screw	2
108	Brush holder cover	2
109	Brush holder	2
110	Label 6	1
111	M6 x 14 outer hexagon head screw	1
112	Switch	1
113	Cable sheath	1
114	ST3.9 x 514 phillips pan head tapping screw	9
115	Tension disc	1
116	Handle	1
117	Handle cover	1
118	M6 x 518 phillips pan head tapping screw	2
119	Handle knob	1
120	Cable plug	1
121	Capacitor	1
122	Inductor	1
123	Laser head	1
124	Battery case	1
125	Battery	2
126	Battery cover	1
127	Switch self-locking button	1
128	Switch torsion spring	1
129	M6 x 8 hexagon socket head screw	1
130	Transparent cover protective roller	2
131	M10 X 50 double-screw bolt	1
133	Cross hexagon wrench	1
134	Label 5	1
138	M4 x 110 phillips pan head screw (white)	1

PARTS LIST

Ref.	Description	Qty.
139	Label 3	1
140	Label 4	1
141	M4 x 18 Phillips pan head screw	1
143	Brand 8	1
144	Laser protecting cover, right	1
145	Laser base	1
146	Locating pin	2
147	Laser protecting cover, left	1
148	3E jump ring	1
149	M4 x 30 special bolt	1
150	M4 x 18 socket head screw	1
151	Compression spring 2	1
152	M4 x 10 socket head screw	1
153	ST3.9 x 516 Phillips pan head tapping screw	2
154	Label 9	1
155	Dust cover	1
156	M4 x 114 phillips pan head screw	2
157	Torsion spring	1
158	Laser stationary shaft	1
159	Laser permanent seat	1
160	Cable cover	1
161	ST3.5 x 8 phillips countersunk head tapping screw	2
162	Laser switch	1
163	Dust cover	1
164	Compression spring	1
165	Sliding fence left	1
166	Sliding fence right	1

EXPLODED DIAGRAM

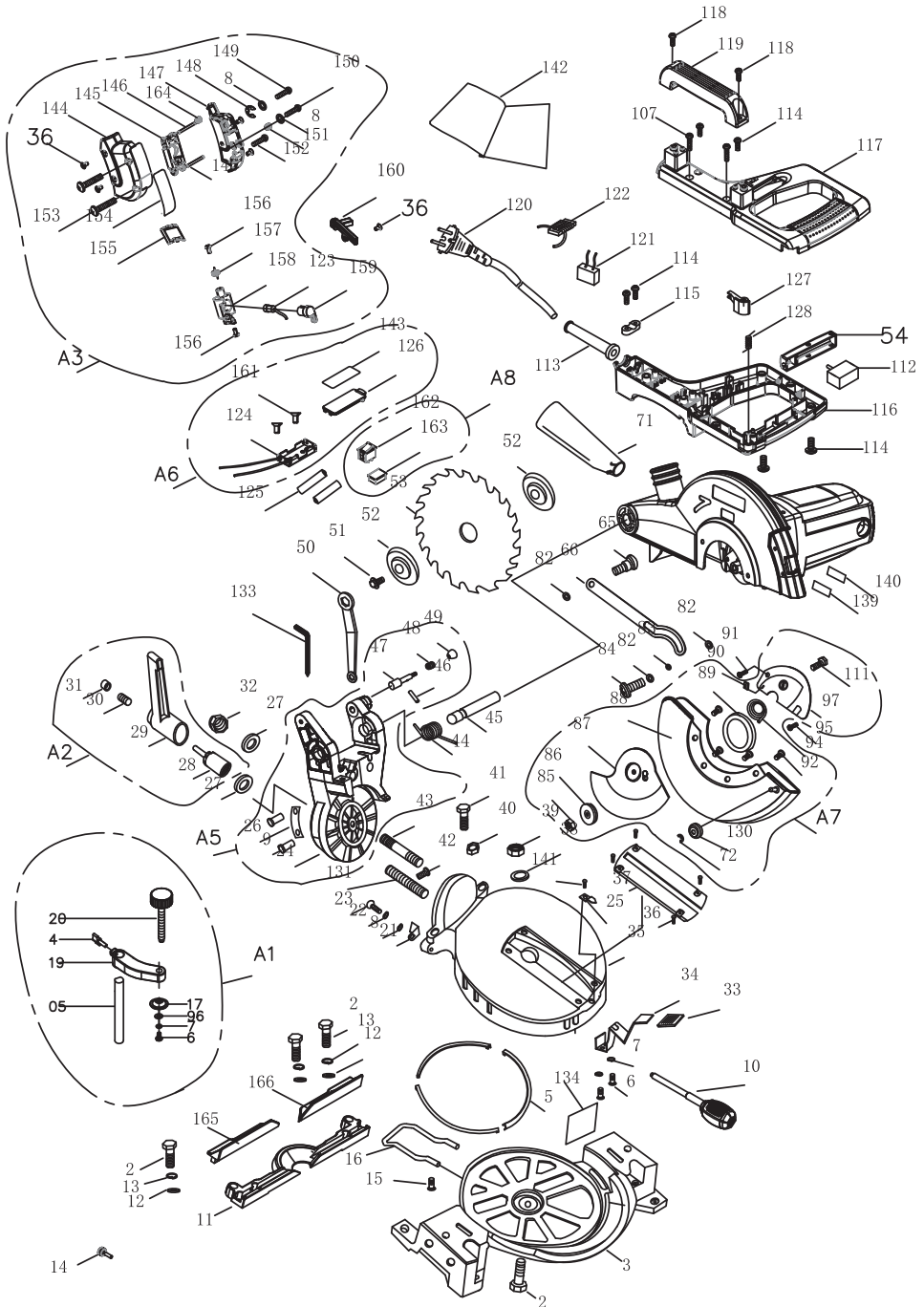

EXPLODED DIAGRAM

