

CROSLLEY

FURNITURE

Dining Table

CF2002

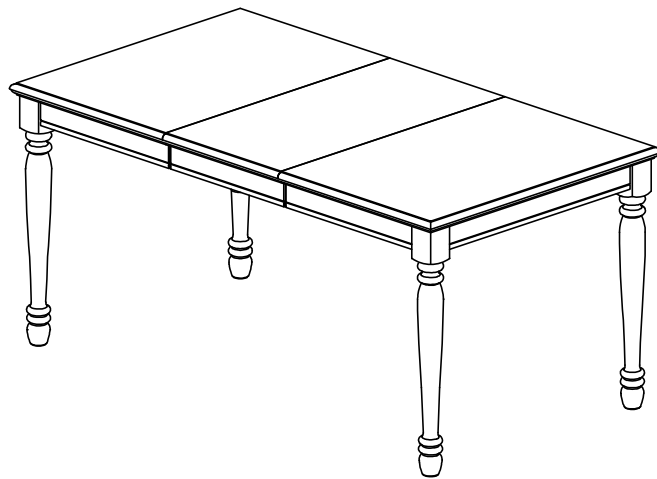

PART LIST

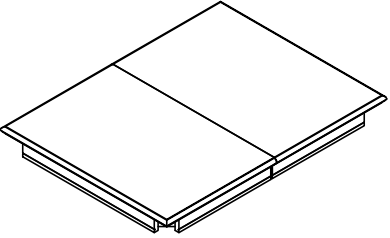
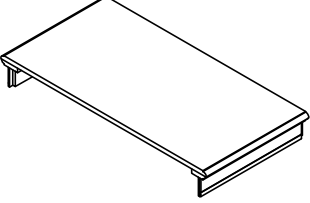
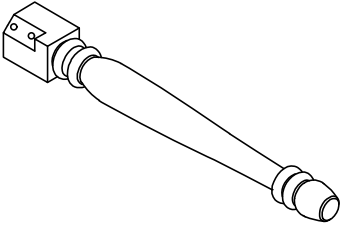
<div data-bbox="119 136 167 190" data-label="Text"> <p>A</p> </div> 	<div data-bbox="582 136 630 190" data-label="Text"> <p>B</p> </div> 	<div data-bbox="1045 136 1093 190" data-label="Text"> <p>C</p> </div> 
<p>Table Top 1 PC</p>	<p>Table Leaf 1 PC</p>	<p>Leg 4 PCS</p>



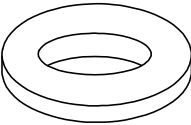
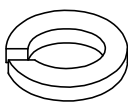
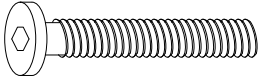
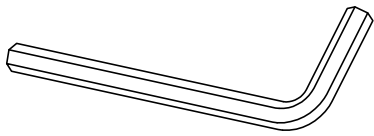
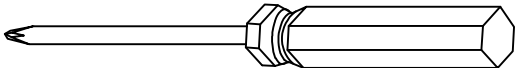

HARDWARE LIST

<div data-bbox="103 938 167 992" data-label="Text"> <p>#1</p> </div>  <p>1/4"</p>	<div data-bbox="566 938 630 992" data-label="Text"> <p>#2</p> </div>  <p>1/4"</p>	<div data-bbox="1037 938 1101 992" data-label="Text"> <p>#3</p> </div>  <p>M8 x 60mm</p>
<p>Flat Washer 8 PCS (Extra 1)</p>	<p>Spring Washer 8 PCS (Extra 1)</p>	<p>Bolt 8 PCS (Extra 1)</p>
<div data-bbox="103 1523 167 1576" data-label="Text"> <p>#4</p> </div>  <p>M5</p> <p>Allen Wrench 1 PC</p>	<p>ADDITIONAL TOOLS (Not Provided)</p> <p>Note: It is not recommended to use power tools during assembly.</p>  <p>Phillips Head Screw Driver</p>	

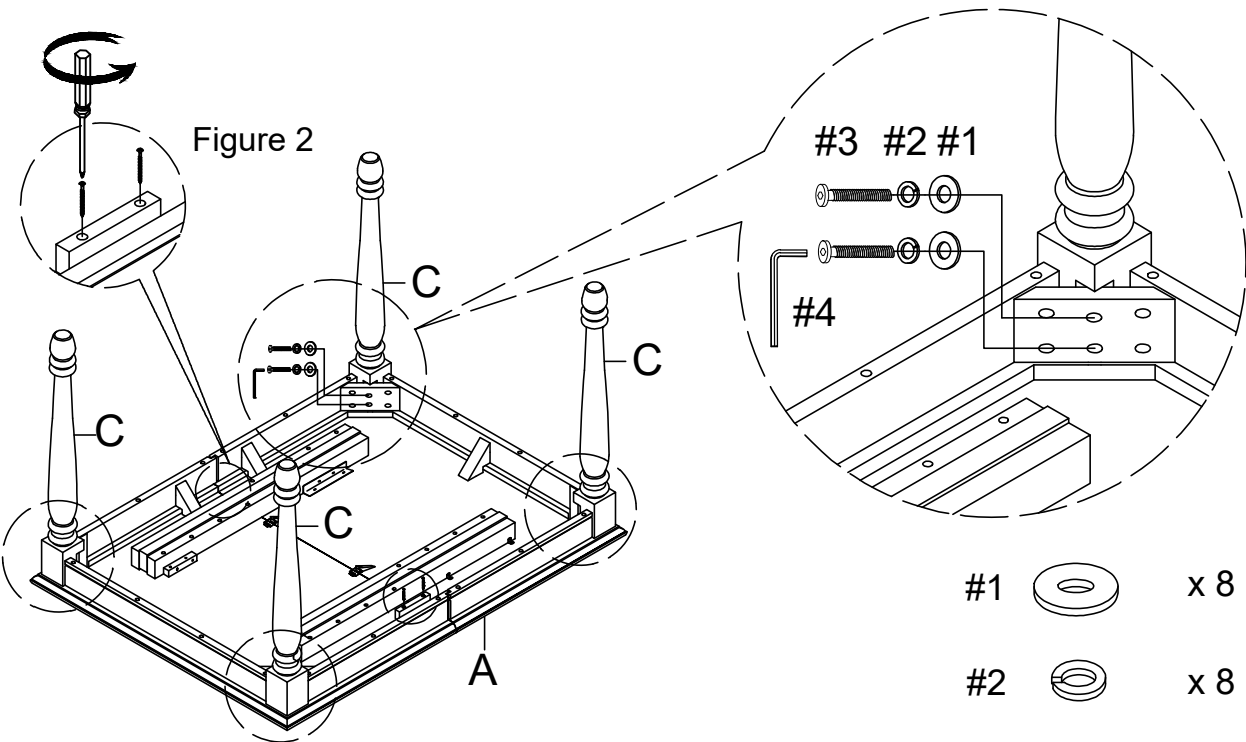
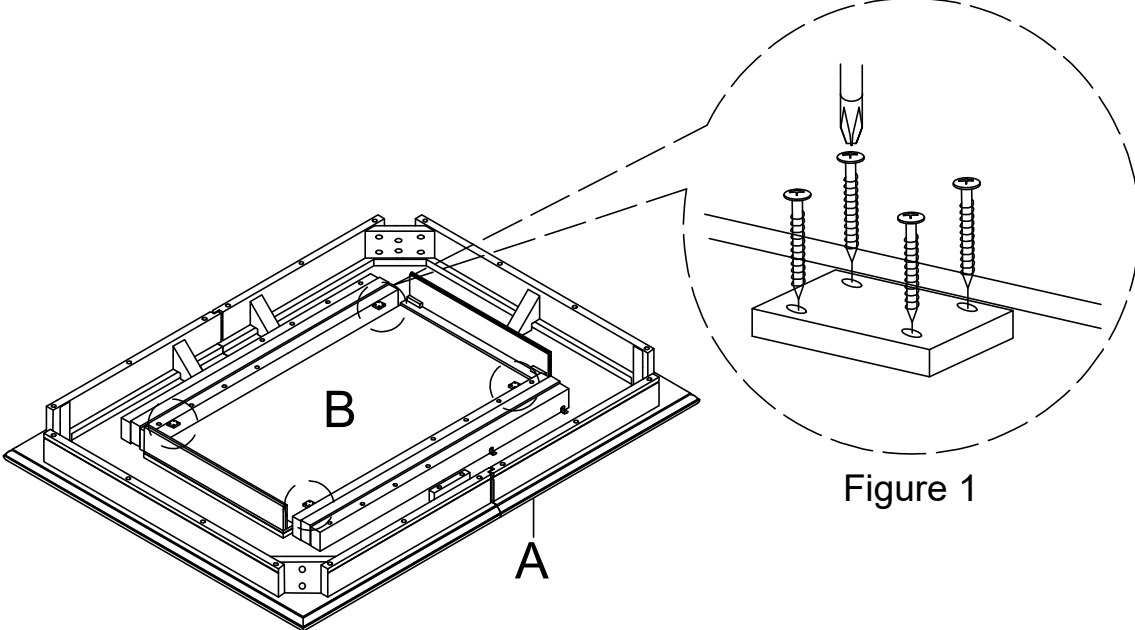
Step 1. Before assembly remove four wood connectors (See Figure 1) and two corner connectors (See Figure 2) using phillips head screwdriver. Carefully place table top (part A) on a soft flat surface, such as carpet. Attach legs (part C) to table top (part A) using spring washers (part #2), flat washers (part #1), bolts (part #3) and allen wrench (part #4).

Note: Please fully tighten all bolts



- #1  x 8
- #2  x 8
- #3  x 8
- #4  x 1

Step 2. Carefully turn unit upright. To insert table leaf (part B), unlock the clamp locks underneath table top (part A) and pull on opposite ends to separate.

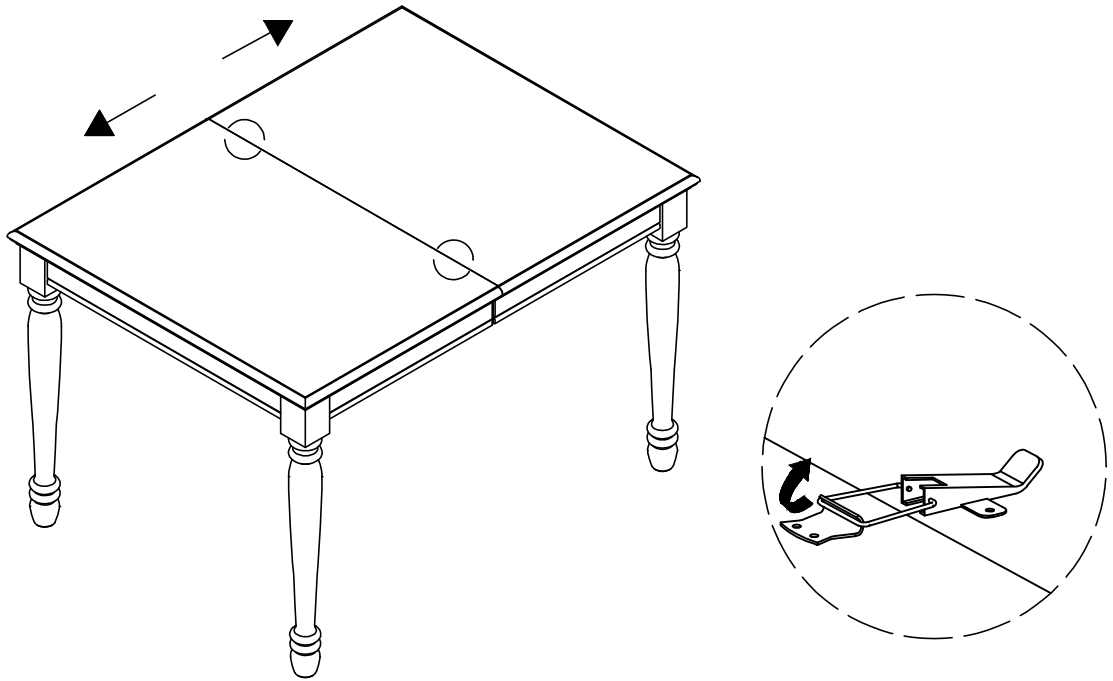

Step 3. Place table leaf (part B) in position and push table top (part A) from both ends to close.

Note: Ensure clamp locks line up correctly when inserting table leaf (part B).

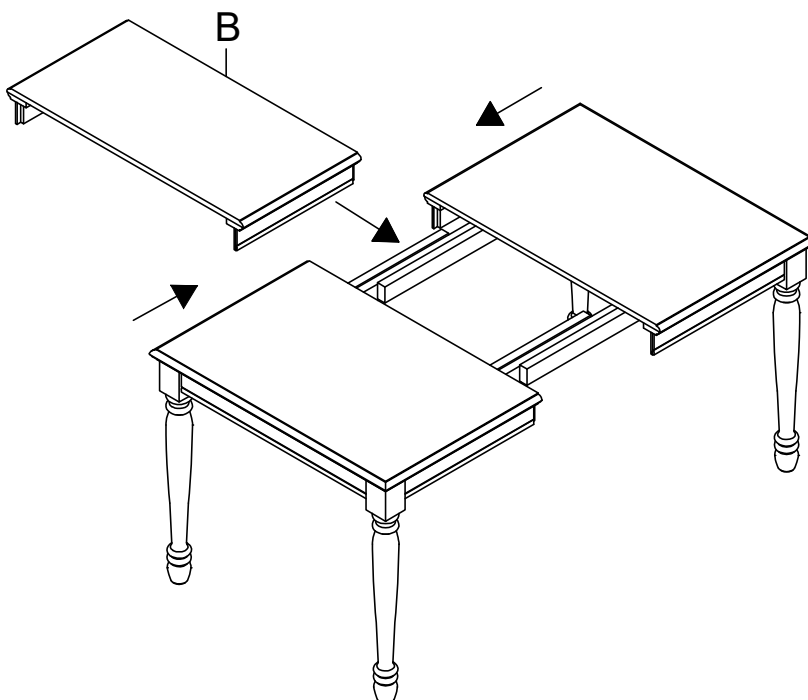

Step 4. Lock clamp locks underneath table top (part A) to secure.

