

# **CROSLLEY**

---

FURNITURE

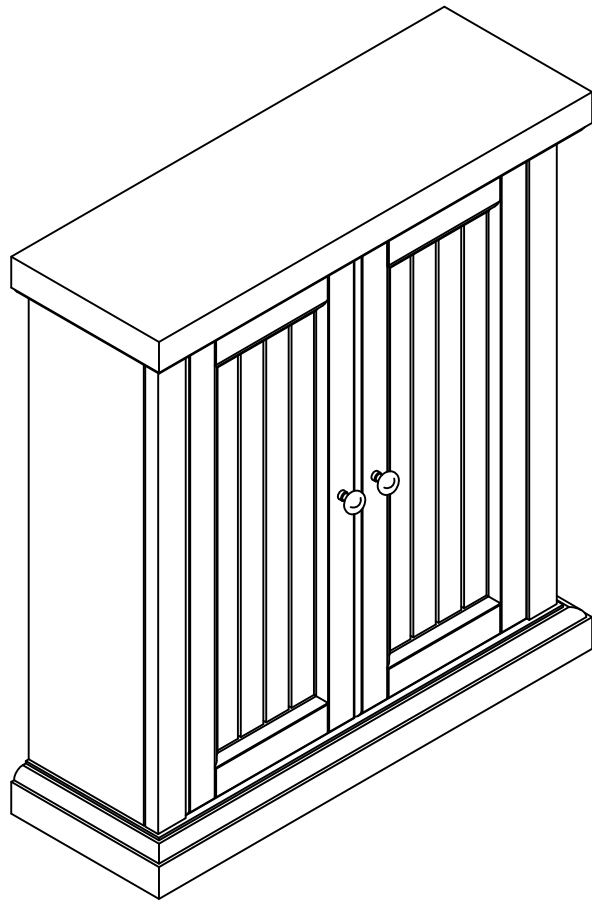





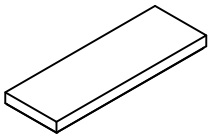
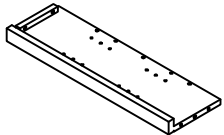
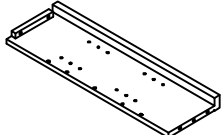
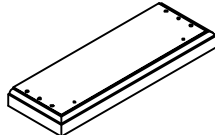
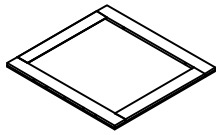
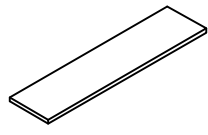
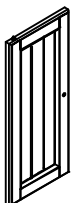
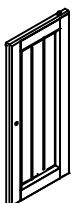
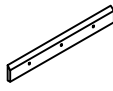





## Wall Cabinet CF7020

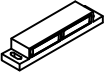

# PART LIST

<p><b>A</b></p> 	<p><b>B</b></p> 	<p><b>C</b></p> 	<p><b>D</b></p> 	<p><b>E</b></p> 
<p>Top Panel 1 PC</p>	<p>Left Panel 1 PC</p>	<p>Right Panel 1 PC</p>	<p>Bottom Panel 1 PC</p>	<p>Back Panel 1 PC</p>
<p><b>F2</b></p> 	<p><b>G</b></p> 	<p><b>H</b></p> 	<p><b>I</b></p> 	
<p>Adjustable Shelf 2 PCS</p>	<p>Left Door Panel 1 PC</p>	<p>Right Door Panel 1 PC</p>	<p>Support Plate 1 PC</p>	

# HARDWARE LIST

 $\phi 1/4" \times 2-1/4"$	 $\phi 1/4" \times 1-1/4"$	 $\phi 1/4"$	 $\phi 1/4" \times 12\text{mm}$	 $\phi 8 \times 30\text{mm}$
Long Bolt 8 PCS	Short Bolt 4 PCS	Spring Washer 12 PCS (Extra 1)	Flat Washer 12 PCS (Extra 1)	Wood Dowel 10 PCS (Extra 1)
 Double Magnet	 $\phi 3 \times 14\text{mm}$ Round Head Screw	 Shelf Holder	 Wall Anchor	 $\phi 8 \times 38\text{mm}$ Long Screw
Double Magnet 1 PC	Round Head Screw 2 PCS	Shelf Holder 8 PCS	Wall Anchor 3 PCS	Long Screw 3 PCS
 Knob	 $\phi 5/32" \times 3/4"$ Round Head Bolt	 Allen Wrench		
Knob 2 PCS	Round Head Bolt 2 PCS	Allen Wrench 1 PC		

## ADDITIONAL TOOLS (Not Provided)

Note: It is not recommended to use power tools during assembly.

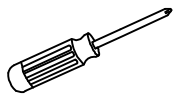

Phillips Head Screwdriver

Note: Wood dowels are intended for alignment. Additional clearance between wood dowel and pre-drilled hole is intentional for ease of assembly.

Step 1. Attach knobs (part #11) to door panels (parts G & H) using round head bolts (part #12) and phillips head screwdriver. Attach double magnet (part #6) to top panel (part A) using round head screws (part #7) and phillips head screwdriver.

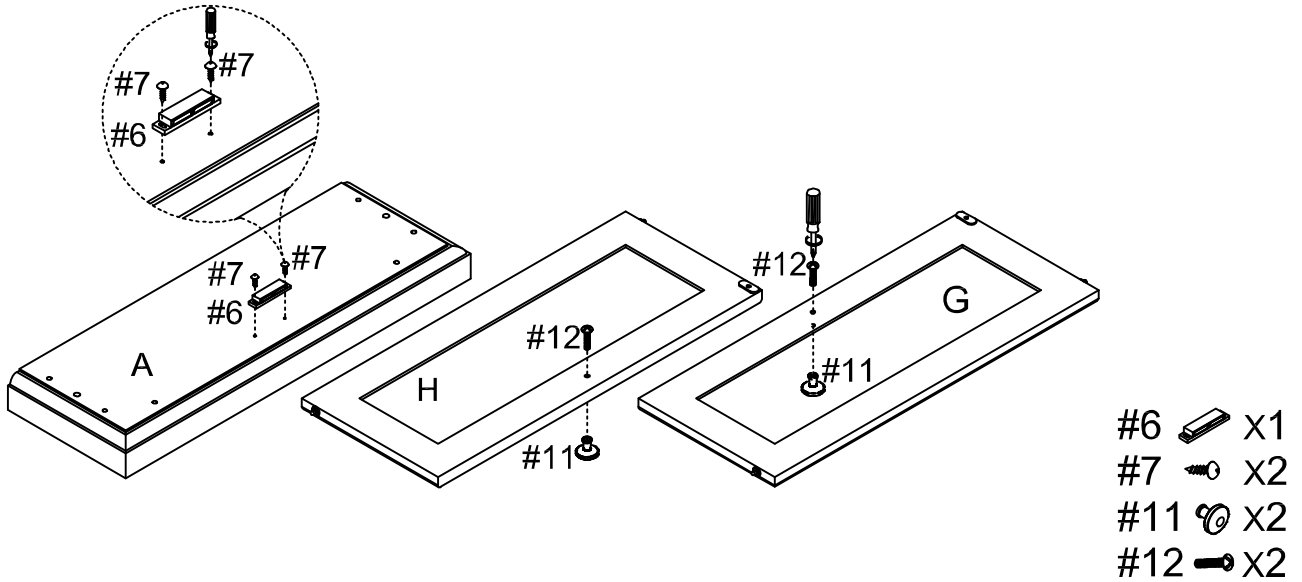



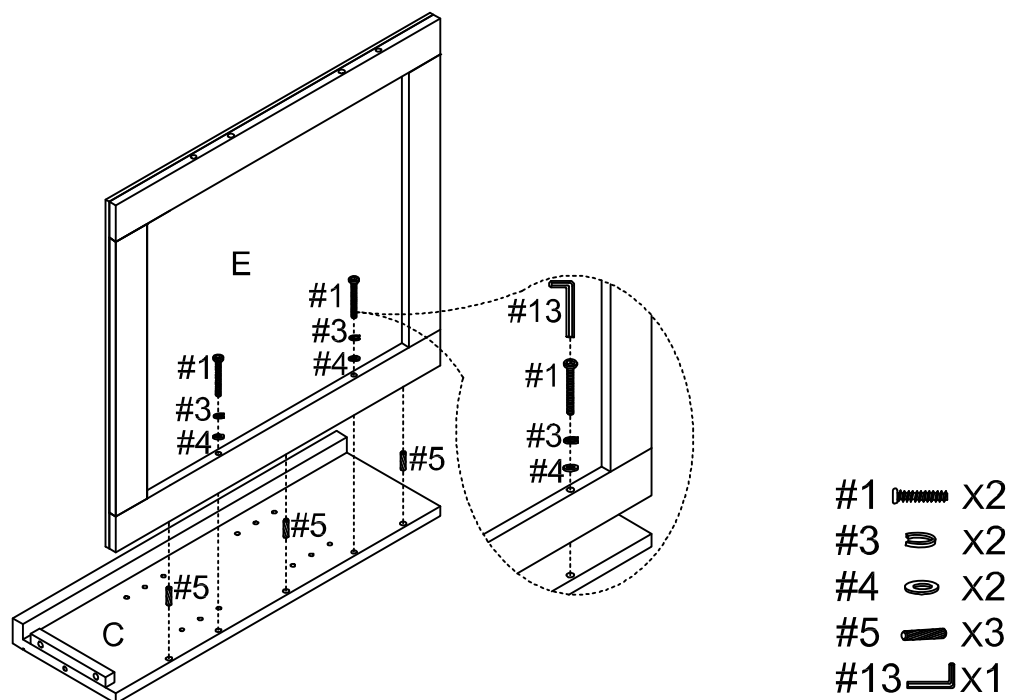

Step 2. Attach back panel (part E) to right panel (part C) using wood dowels (part #5), long bolts (part #1), spring washers (part #3), flat washers (part #4) and allen wrench (part #13).

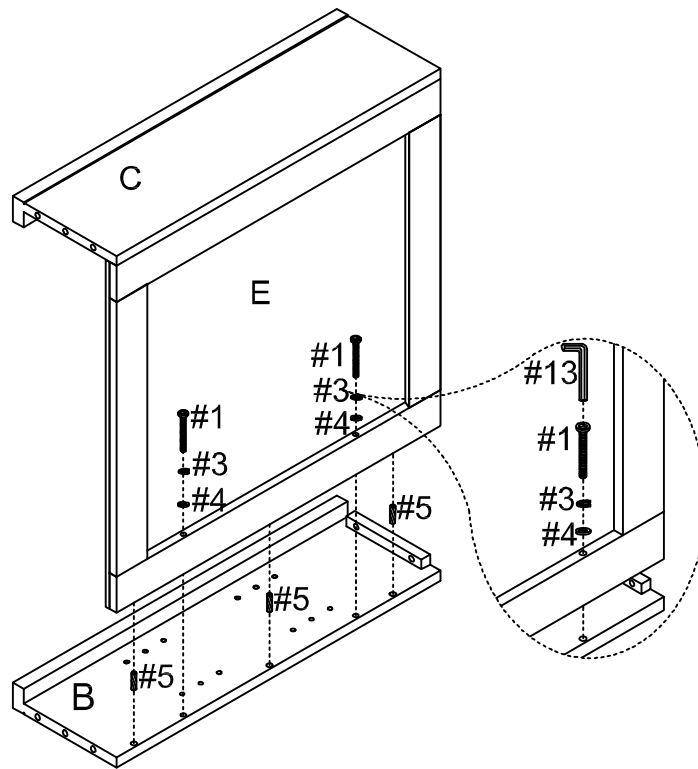







Step 3. Attach left panel (part B) to back panel (part E) using wood dowels (part #5), long bolts (part #1), spring washers (part #3), flat washers (part #4) and allen wrench (part #13).

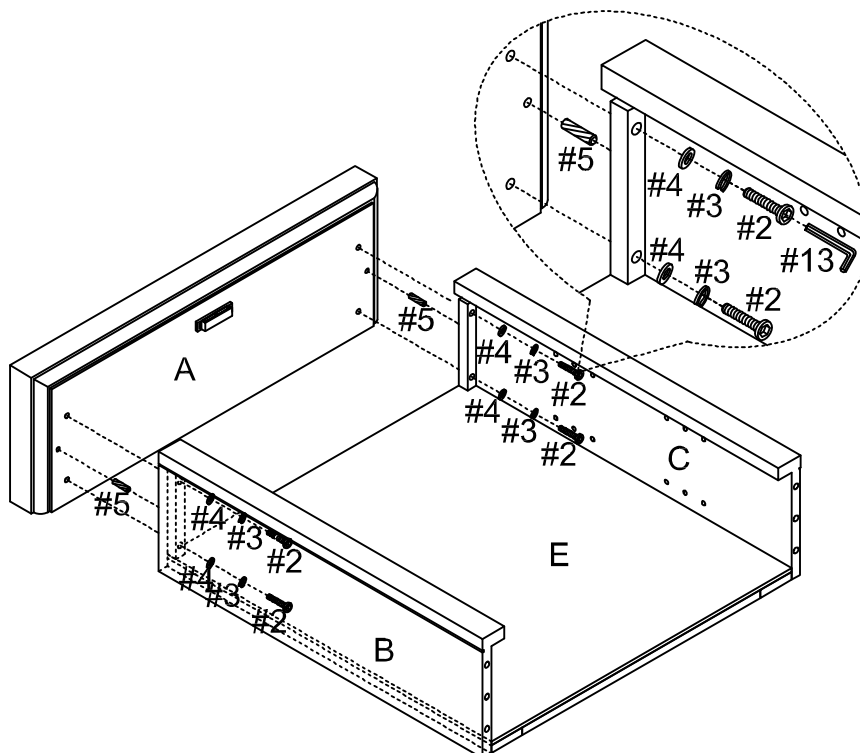

- #1  X2
- #3  X2
- #4  X2
- #5  X3
- #13  X1

Step 4. Attach top panel (part A) to assembled unit (parts B, C & E) using wood dowels (part #5), short bolts (part #2), spring washers (part #3), flat washers (part #4) and allen wrench (part #13).



- #2  X4
- #3  X4
- #4  X4
- #5  X2
- #13  X1

Step 5. Attach bottom panel (part D) to assembled unit (parts B, C & E) using wood dowels (part #5), long bolts (part #1), spring washers (part #3), flat washers (part #4) and allen wrench (part #13).

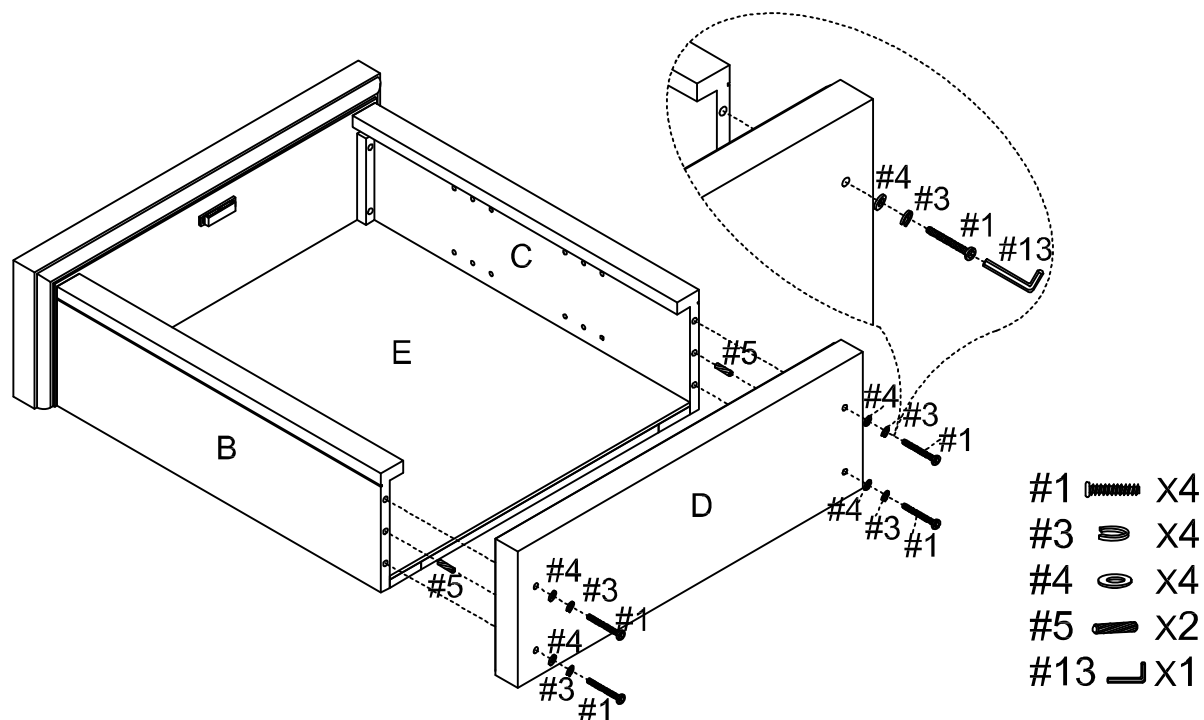

Step 6. Carefully turn unit upright. Attach door panels (parts G & H) by placing bottom pin hinge (pre-installed in door) in the pre-drilled hole of bottom panel (part D). Then depress the top spring-loaded pin hinge so it can be placed in the pre-drilled hole of top panel (part A).

Note: Be sure top and bottom pin hinges are fully extended to secure doors in place.

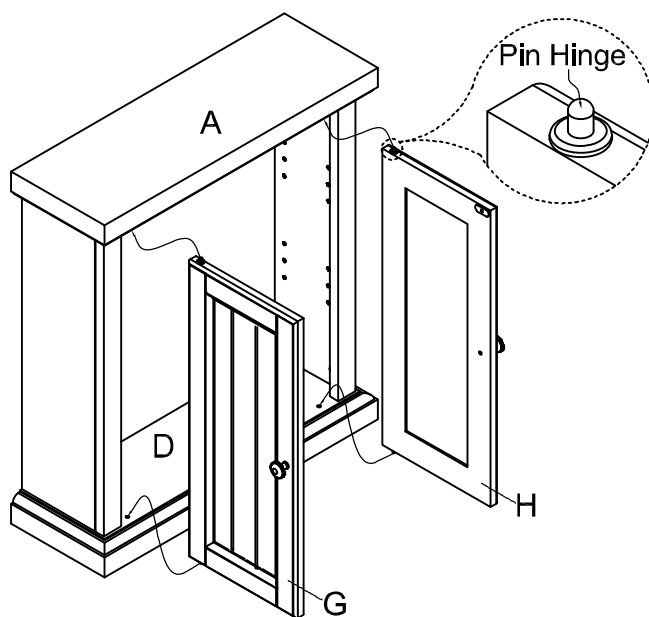

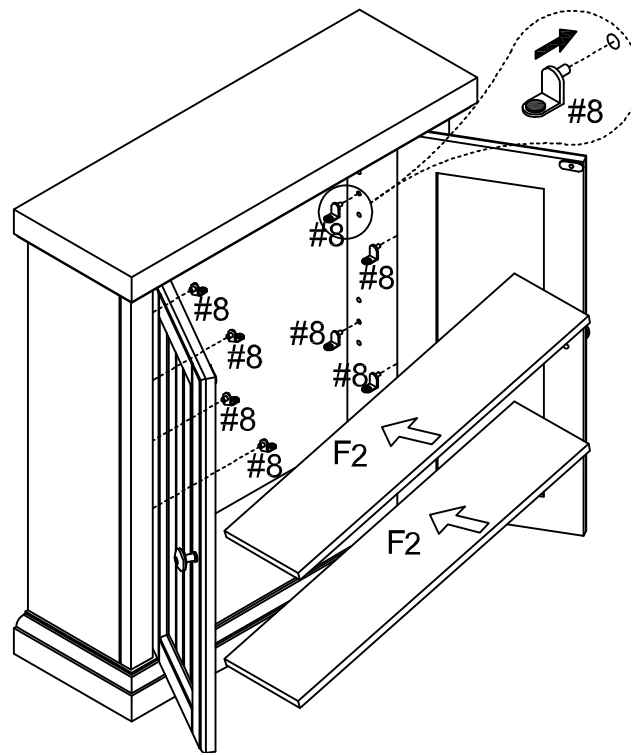

Step 7. Place shelf holders (part #8) into desired position and then slide adjustable shelves (part F2) into place.

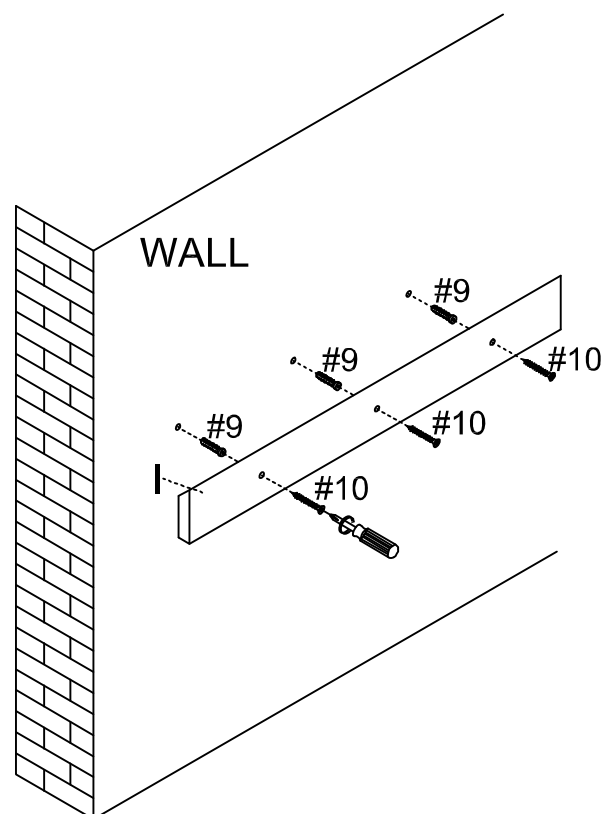

#8  X8

Step 8. Drill three 11/32" holes in the wall and tap wall anchors (part #9) in to the drilled holes. Secure support plate (part I) to wall anchors (part #9) using long screws (part #10) and phillips head screwdriver.



#9  X3  
#10  X3

Step 9. Hang back panel (part E) on support plate (part I).

