

Diaphragm Pumps

Engineered for Excellence

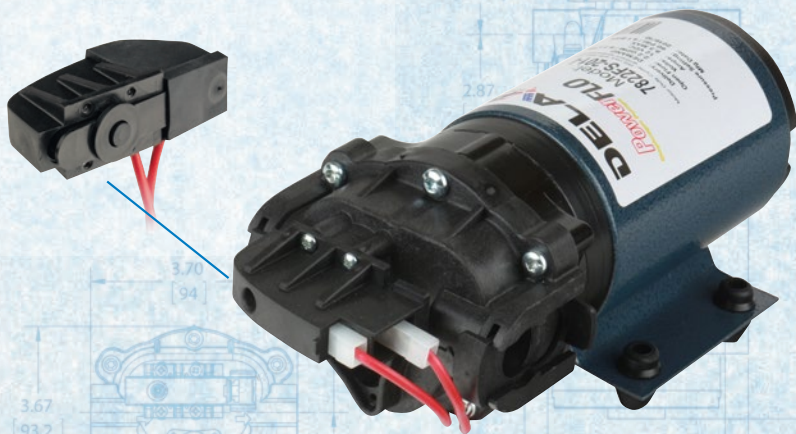

Extreme Duty Demand Diaphragm Pump

Demand Pumps include a built in pressure switch to automatically start and stop the pump at specific pressure settings.

Pump Type: Demand

Flow: Up to 5.4 GPM

Pressure: Up to 60 PSI

Valves: Viton

Diaphragm: Geolast

Ports: 3/8" FNPT, 3/4" Quick Attach, 1/2" FNPT

Power: 12V – Wire Leads with 2-pin molded connector

Weight: 6, 8 lbs.

Packaging: Bulk Box, Retail Box

Shipping: 6 per carton, single

- Extreme Duty components built to withstand oil and diesel blends
- Resilient Geolast Diaphragm for longer life when spraying harsh chemicals
- 100% Factory tested
- High Torque Motor for superior flow at pressure
- Self-Priming
- Can be run dry



DIAPHRAGM PUMPS

Performance Specifications

2.0 GPM Demand

PSI	GPM	AMPS
0	1.7	4.5
10	1.7	4.5
20	1.6	5.2
30	1.55	5.9
40	1.5	6.7
50	1.45	8

2.2 GPM Demand

PSI	GPM	AMPS
0	2.2	4.5
10	2.2	4.7
20	2.1	6.1
30	1.9	6.9
40	1.8	7.2
50	1.65	8.1

5.0 GPM Demand

PSI	GPM	AMPS
0	5.4	8.2
10	4.6	10.4
20	4.1	12.5
30	3.7	15.1
40	3.2	16.3
50	2.8	17.1

Extreme Duty Bypass-Demand Diaphragm Pump Product Listing

Item #	GPM	PumpType	PSI	Valves	Diaphragm	Ports	Wire Leads
7812ED-201-SB	2	Demand	60	Viton	Geolast	3/8" FNPT	•
7822FSED-201-SB	2.2	Demand	60	Viton	Geolast	3/4" QA	•
5850ED-201C-SB	5	Demand	45	Viton	Geolast	1/2" FNPT	•

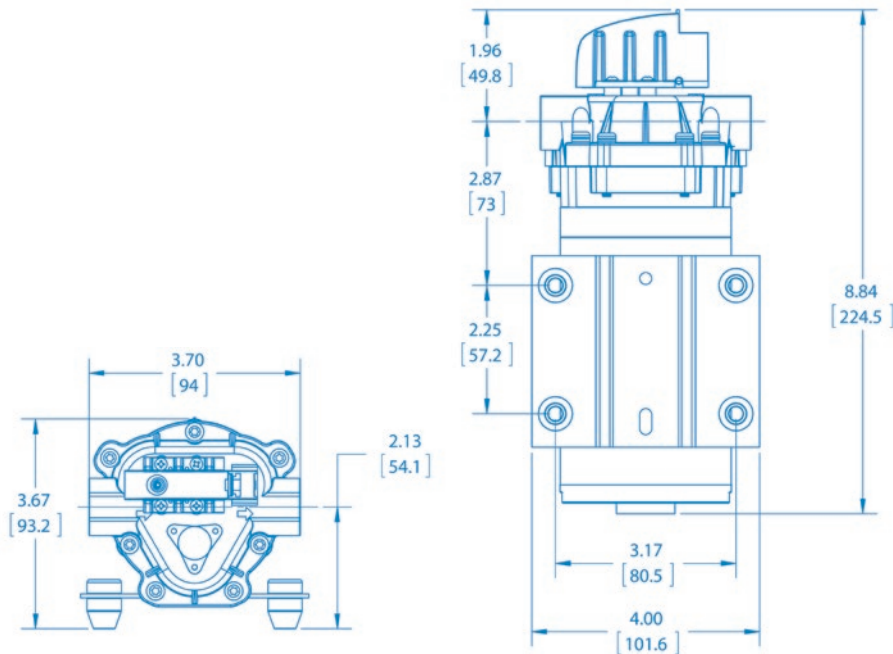

Engineered for Excellence

"We are committed to succeeding in today's increasingly challenging marketplace by responding to each varied and dynamic individual customer requirement with an exclusive and custom tailored solution."