OPERATOR'S MANUAL



KC1130S Snow Blower

IMPORTANT
READ INSTRUCTIONS CAREFULLY BEFORE OPERATION!

SAFE OPERATION PRACTICES

1



WARNING: This symbol points out important safety instructions which, if not followed, could endanger the personal safety and/or property of yourself and others. Read and follow all instructions in this manual before attempting to operate this machine. Failure to comply with these instructions may result in personal injury.

When you see this symbol. **HEED ITS WARNING!**



DANGER: This machine was built to be operated according to the rules for safe operation in this manual. As with any type of power equipment, carelessness or error on part of the operator can result in serious injury. This machine is capable of amputating hands and feet and throwing objects. Failure to observe the following safety instructions could result in serious injury or death.



WARNING: Engine Exhaust, some of its constituents, and certain vehicle components contain or emit chemicals known to cause cancer and birth defects or other reproductive harm.

IMPORTANT

Safe Operation Practices for Walk-Behind Snow Throwers

This snow thrower is capable of amputating hands and feet and throwing objects. Failure to observe the following safety instructions could result in serious injury.

Training

1. Read, understand, and follow all instructions on the machine and in the manual(s) before attempting to assemble and operate this unit. Keep this manual in a safe place for future and regular reference and for ordering replacement parts.
2. Be familiar with all controls and their proper operation. Know how to stop the machine and disengage them quickly.
3. Thrown objects can cause serious personal injury. Plan your snow-throwing pattern to avoid discharge of material toward roads, bystanders and the like.
4. Never allow children under 15 years old to operate this machine. Children 15 years old and over should read and understand the operation instruction and safety rules in this manual and should be trained and supervised by parent.

5. Never allow adults to operate this machine without proper instruction.
6. Keep bystanders, helpers, pets and children at least 75 feet from the machine while it is in operation. Stop machine if anyone enters the area.
7. Exercise caution to avoid slipping or falling, especially when operating in reverse.

Preparation

1. Thoroughly inspect the area where the equipment is to be used. Remove all doormats, newspapers, sleds, boards, wires and other foreign objects, which could be tripped over or thrown by the auger/impeller.
2. Always wear safety glasses or eye shields during operation and while performing an adjustment or repair to protect your eyes. Thrown objects which ricochet can cause serious injury to the eyes.

3. Do not operate the equipment without wearing adequate winter garments. Avoid loose fitting clothing that can get caught in moving parts. Do not wear jewelry, long scarves or other loose clothing, which could become entangled in moving parts. Wear footwear which will improve footing on slippery surfaces.
4. Use a grounded three-wire extension cord and receptacle for all units with electric start engines.
5. Adjust collector housing height to clear gravel or crushed rock surfaces.
6. Disengage all clutches and shift into neutral before starting the engine.
7. Never attempt to make any adjustments while engine is running, except where specifically recommended in the operator's manual.
8. Let engine and machine adjust to outdoor temperature before starting to clear snow.
9. To avoid personal injury or property damage use extreme care in handling gasoline. Gasoline is extremely flammable and the vapors are explosive. Serious personal injury can occur when gasoline is spilled on yourself or your clothes, which can ignite. Wash your skin and change clothes immediately.
 - a. Use only an approved gasoline container.
 - b. Extinguish all cigarettes, cigars, pipes and other sources of ignition.
 - c. Fill fuel tank outdoors with extreme care. Never fill fuel tank indoors.
 - d. Never remove gas cap or add fuel while the engine is hot or running.
 - e. Allow engine to cool at least two minutes before refueling.
 - f. Never over fill fuel tank. Fill tank to no more than 1/2 inch below bottom of filler neck to provide space for fuel expansion.
 - g. Never fill containers inside a vehicle or on a truck or trailer bed with a plastic liner. Always place containers on the ground, away from your vehicle, before filling.
 - h. When practical, remove gas-powered equipment from the truck or trailer and refuel it on the ground. If this is not possible, then refuel such equipment on a trailer with a portable container, rather than from a gasoline dispenser nozzle.
 - i. Keep the nozzle in contact with the rim of the fuel tank or container opening at all times, until refueling is complete. Do not use a nozzle lock-open device.
 - j. Replace gasoline cap and tighten securely.
 - k. If gasoline is spilled, wipe it off the engine and equipment. Move machine to another area. Wait 5 minutes before starting the engine.
 - l. Never store the machine or fuel container inside where there is an open flame, spark or pilot light (e.g. furnace, water heater, space heater, clothes dryer etc.)
 - m. Allow machine to cool at least 5 minutes before storing.
 - n. If fuel is spilled on clothing, change clothing immediately.

General Operation

1. Do not put hands or feet near rotating parts, in the auger/impeller housing or chute assembly. Contact with the rotating parts can amputate hands and feet. Keep clear of the discharge opening at all times.
2. After striking a foreign object, stop the engine (motor), remove the wire from the spark plug, disconnect the cord on electric motors, thoroughly inspect the snow thrower for any damage, and repair the damage before restarting and operating the snow thrower.

3. Stop the engine (motor) whenever you leave the operating position, before unclogging the collector/impeller housing or discharge chute, and when making any repairs, adjustments or inspections.
4. When cleaning, repairing or inspecting the snow thrower, stop the engine and make certain the collector/impeller and all moving parts have stopped. Disconnect the spark plug wire and keep the wire away from the plug to prevent someone from accidentally starting the engine
5. The auger/impeller control lever is a safety device. Never bypass its operation. Doing so makes the machine unsafe and may cause personal injury.
6. The control levers must operate easily in both directions and automatically return to the disengaged position when released.
7. Never operate the snow thrower without proper guards, and other safety protective devices in place and working.
8. Never run an engine indoors or in a poorly ventilated area. Engine exhaust contains carbon monoxide, odorless, deadly gas.
9. Do not operate machine while under the influence of alcohol or drugs.
10. Exercise extreme caution when operating on or crossing gravel surfaces. Stay alert for hidden hazards or traffic.
11. Exercise caution when changing direction and while operating on slopes.
12. Plan your snow-throwing pattern to avoid discharging towards windows, walls, cars etc. Thus, avoiding possible property damage or personal injury caused by a ricochet.
13. Never direct the discharge toward people or areas where property damage can occur.
14. Do not overload machine capacity by attempting to clear snow at too fast rate.
15. Never operate this machine without good visibility or light. Always be sure of your footing and keep a firm hold on the handles. Walk, never run.
16. Disengage power to the auger/impeller when transporting or not in use.
17. Never operate machine at high transport speeds on slippery surfaces. Look down and behind and use care when backing up.
18. If the machines should start to vibrate abnormally, stop the engine, disconnect the spark plug wire and ground it against the engine. Inspect thoroughly for damage. Repair any damage before starting and operating.
19. Disengage all control levers and stop engine before you leave the operating position(behind the handles). Wait until the auger/impeller comes to a complete stop before unclogging the chute assembly, making any adjustments, or inspections.
20. Never put your hand in the discharge or collector openings. Always use the clean-out tool provided to unclog the discharge opening. Do not unclog chute assembly while engine is running. Shut off engine and remain behind handles until all moving parts have stopped before unclogging.
21. Use only attachments and accessories approved by the manufacturer (e.g. wheel weights, tire chins, cabs etc.).
22. Never touch a hot engine or muffler.
23. If situations occur which are not covered in this manual, contact your Service Center for assistance.

Clearing a Clogged Discharge

Chute

Hand contact with the rotating impeller inside the discharge chute is the most common cause of injury associated with snow throwers. Never use your hand to clean out the discharge chute.

To clear the chute:

1. SHUT THE ENGINE OFF!
2. Wait 10 seconds to be sure the impeller blades have stopped rotating.
3. Always use a clean-out tool, not your hands.

Maintenance & Storage

1. Never tamper with safety devices. Check their proper operation regularly. Refer to the maintenance and adjustment sections of this manual.
2. Before cleaning, repairing, or inspecting machine, disengage all control levers and stop the engine. Wait until the auger/impeller come to a complete stop. Disconnect the spark plug wire and ground against the engine to prevent unintended starting.
3. Check bolts and screws for proper tightness at frequent intervals to keep the machine in safe working condition. Also, visually inspect machine for any damage.
4. Do not change the engine governor setting or over-speed the engine.
5. Snow thrower shave plates and skid shoes are subject to wear and damage. For your safety protection, frequently check all components and replace with original equipment manufacturer's (OEM) parts only. "Use of parts which do not meet the original equipment specifications may lead to improper performance and compromise safety!"
6. Check controls periodically to verify they engage section in this operator's manual for instructions.
7. Maintain or replace safety and instruction labels, as necessary.
8. Never store the machine with fuel inside a building where ignition sources are present such as hot water heaters, space heaters, or clothes dryers. Allow the engine to cool before storing in any enclosure.
9. Observe proper disposal laws and regulations for gas, oil, etc. to protect the environment.
10. Prior to storing, run machine a few minutes to clear snow from machine and prevent freeze up of auger/impeller.
11. Never store the machine or fuel container inside where there is an open flame, spark or pilot light such as a water heater, furnace, clothes dryer etc.
12. Always refer to the operator's manual for proper instructions on off-season storage.



WARNING: Your Responsibility: Restrict the use of this power machine to persons who read, understand and follow the warnings and instructions in this manual and on the machine.

SAVE THESE INSTRUCTIONS!

IMPORTANT

Refer to your Massimo Owner's Manual for any information relating to the use of your snow blower. These instructions are for assembly of your new accessory to further enhance your snow blower experience.

Installing the Snow Blower

1. Forward and drive control cable assembly

Couple the cable eyelet to the specific opening (fig. 1).

NOTE: The cables are already pre-assembled on the dashboard.

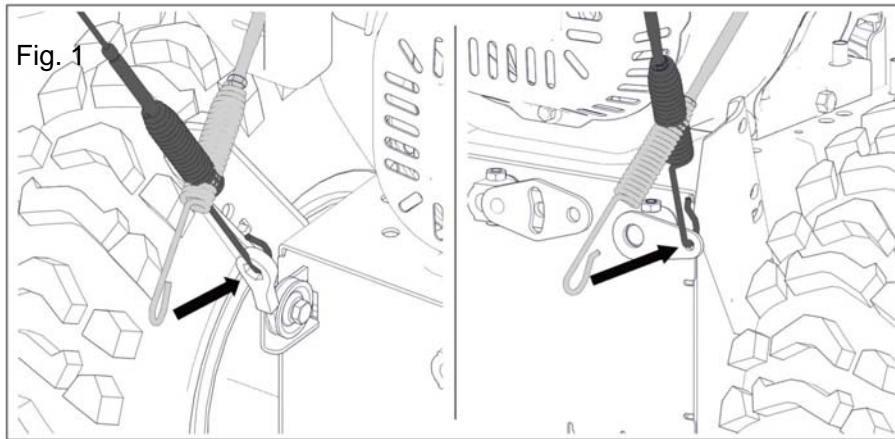

2. Handle assembly

The handle is delivered with the dashboard already assembled. The machine handle assembly screws, gear control fastening screws and nuts and bolts to secure the brush directional control are delivered in a separate package found in the machine packaging. Install as follows:

- Bring the two tubes at the ends of the handle (Fig. 2 A) up to the support (Fig. 2 B).
- Insert the screws in the holes and secure in place with the nuts.

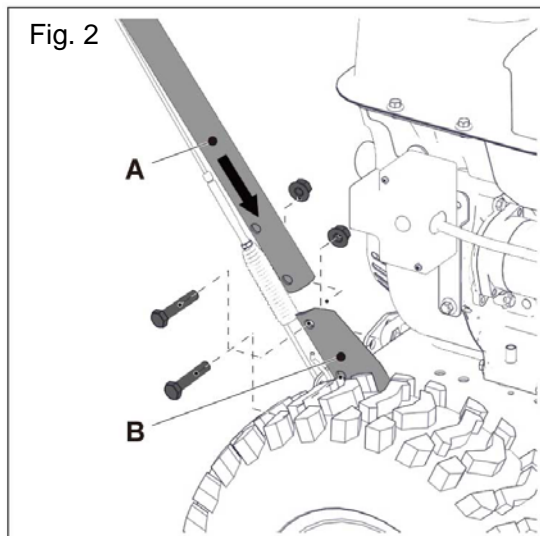

2

Installing the Snow Blower



IMPORTANT

Refer to your Massimo Owner's Manual for any information relating to the use of your snow blower. These instructions are for assembly of your new accessory to further enhance your snow blower experience.

Specifications subject to change without notice or obligation

2

Installing the Snow Blower



IMPORTANT

Refer to your Massimo Owner's Manual for any information relating to the use of your snow blower. These instructions are for assembly of your new accessory to further enhance your snow blower experience.

Specifications subject to change without notice or obligation

3. Installation of the gear control

Insert the assembled articulated joint to the gear control and fix it with B pin (Fig. 3).

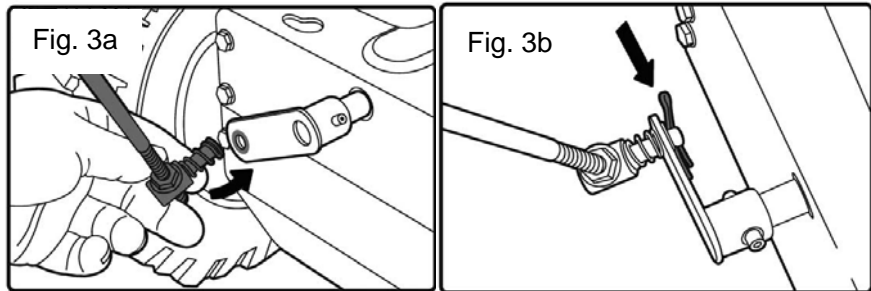

4. Mount the control handles:

Place the handle on the rod, and fix it tight in right direction (Fig. 4).

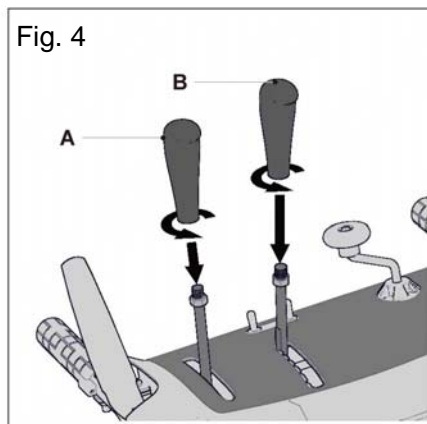

5. Mount the chute:

- Position the sliding ring (Fig. 5 A) and the discharge chute (Fig. 5 B) on the flange fitting (Fig. 5 C).
- Insert the skids (Fig. 5 D) under the flange fitting (Fig. 5 C) by matching up the holes on the skid with holes at the bottom of the chute.
- Insert the screws with washers (Fig. 5 E) in the holes and fasten.
- Secure the worm screw unit onto the support, checking the correct engagement of the worm screw unit with the toothed section on the chute (Fig. 5 F).

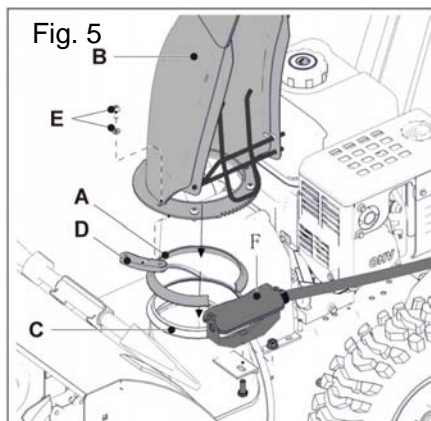

2

Installing the Snow Blower



IMPORTANT

Refer to your Massimo Owner's Manual for any information relating to the use of your snow blower. These instructions are for assembly of your new accessory to further enhance your snow blower experience.

Specifications subject to change without notice or obligation

6. Installation of deflector adjustment cable:

- Insert the peg (Fig. 6 B) on the end part of the activation lever.
- Insert the B pin on the peg (Fig. 6 C) and secure in place.
- Insert the adjustment screw (Fig. 6 A) on the support (Fig. 6 D) and tighten the nut.

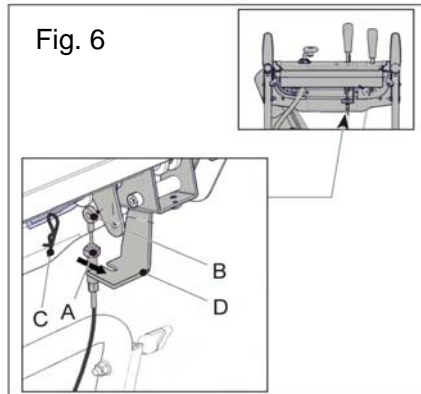

7. Installation of engine cover:

- Take out supporting frame 1 & 2 from accessories, and fix them to the engine as shown in Fig. 7-1.
- Fix the gasoline engine cover on the two supporting frames. See Fig. 7-2.

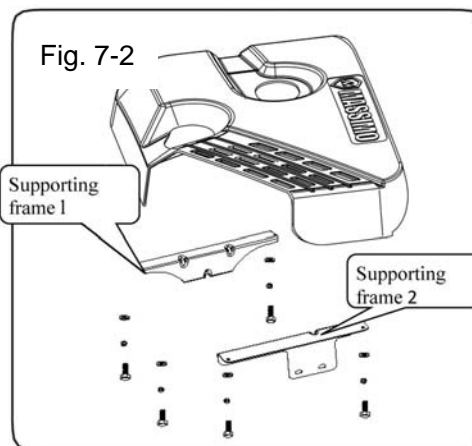
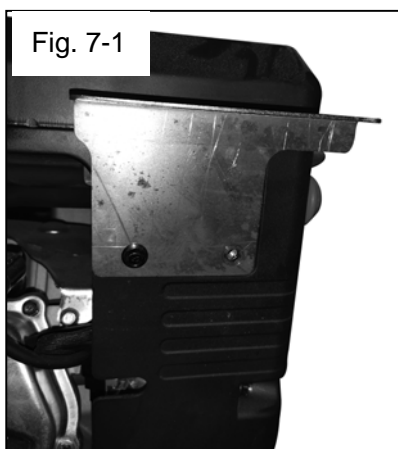

3

Activate and Use



IMPORTANT

Refer to your Massimo Owner's Manual for any information relating to the use of your snow blower. These instructions are for assembly of your new accessory to further enhance your snow blower experience.

Specifications subject to change without notice or obligation

Before Starting Engine

Add Oil

Do not start the engine until filled with oil. The engine can be seriously damaged without oil .

1. Place the machine on a level floor.
2. Loosen the dipstick and read the oil level. See Fig 8
3. The oil level shall be between the marks "HIGH" and "LOW". See Fig 8.
4. It necessary fill with oil up to the FULL mark. See Fig.8.
5. Use good quality oil marked A.P.I. service SF, SG or SH. Use SAE 5W30 oil. Use SAE OW30 oil for temperatures under -18 °C. Do not use SAE 10W50.

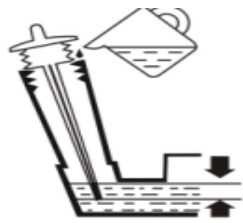
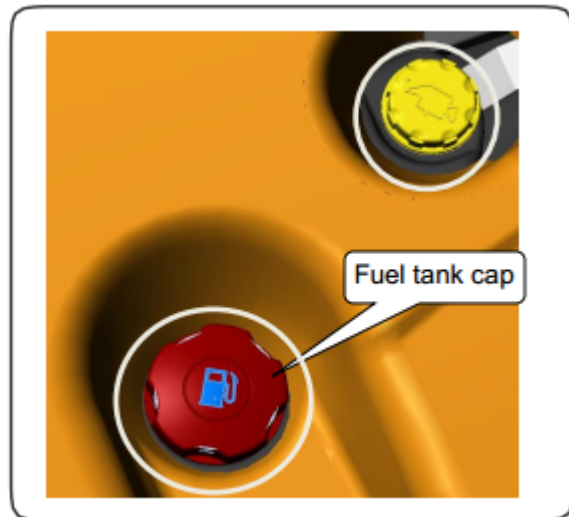

Fig. 8



Add Gasoline



WARNING: Use extreme care when handling gasoline is extremely flammable and the vapors are explosive. Never fuel the machine indoors or while the engine is hot or running. Extinguish cigarettes, cigars, pipes and other sources of ignition.

- Store gasoline in a clean, approved container and keep the cap in place on the container.
- Make sure that the container from which you pour the gasoline is clean and free from rust or other foreign particles.
- Always fill the fuel tank outdoors and use a funnel or spout to prevent spilling.
- Fill fuel tank with clean, fresh, unleaded gasoline.
- Never fill the fuel tank completely. Fill the tank to within 1/2" from the top to provide space for expansion of fuel.
- Make sure to wipe off any spilled fuel before starting the engine.

Start The Engine

1. Attach spark plug wire to spark plug. Make certain the metal loop on the end of the spark plug wire (inside the rubber boot) is fastened securely over the metal tip on the spark plug.
 2. Make certain both the auger control and drive control are in the disengaged (released) position.
 3. Move throttle control up to FAST position. Insert ignition key into slot. Make sure it snaps into place. Do not attempt to turn the key.
- NOTE :** The engine cannot start without the key is fully inserted into the ignition switch.

Electric Starter

Determine that your home's wiring is a two-wire grounded system. Ask a licensed electrician if you are not certain.



WARNING: The optional electric starter is equipped with a grounded two-wire power plug, and is designed to operate on 110 volt AC household current. It must be used with a properly grounded two-prong receptacle at all times to avoid the possibility of electric shock.

If your home's wiring system is not a grounded system, do not use this electric starter under any conditions.

If your home electrical system is grounded, but a two-hole extension cord is not available, do not use your snow thrower's electric starter. Follow all instructions carefully prior to operating the electric starter. If you have all of the above, proceed as follows:

- 1) Plug the extension cord into the outlet located on the engine's surface. Plug the other end of extension cord into a 110-volt, grounded, AC outlet in a well-ventilated area.
- 2) Rotate choke control to FULL choke position (for a cord engine start).

NOTE: If the engine is already warm , place choke control in the OFF position instead of FULL.

- 3) Push the primer to restart a warm engine start, marking sure to cover vent hole in the center of the primer when pushing .

NOTE: DO NOT use primer to restart a warm engine after a short shutdown.

- 4) Push start button to start engine.
 - 5) Once the engine starts, release starter button.
 - 6) AS the engine warms, slowly rotate the choke control to the OFF position. if the engine falters, quickly rotate the choke control back to FULL and then slowly into the OFF position again.
 - 7) When disconnecting the extension cord, always unplug the end at the wall outlet unplugging the opposite end form the snow thrower.
-

3

Activate and Use



IMPORTANT

Refer to your Massimo Owner's Manual for any information relating to the use of your snow blower. These instructions are for assembly of your new accessory to further enhance your snow blower experience.

Specifications subject to change without notice or obligation

3

Activate and Use



IMPORTANT

Refer to your Massimo Owner's Manual for any information relating to the use of your snow blower. These instructions are for assembly of your new accessory to further enhance your snow blower experience.

Specifications subject to change without notice or obligation

Start The Engine

Recoil Starter

1. Rotate choke control to FULL choke position (cold engine start).

NOTE: If the engine is already warm, place choke control in the OFF position instead of FULL.

2. Push the primer two or three times for cold engine start, making sure to cover vent hole in the center of the primer when pushing.

NOTE: DO NOT use primer to restart a warm engine after a short shutdown.

NOTE: Additional priming maybe necessary if the temperature is below -10° Centigrade.

3. Grasp the recoil starter handle and slowly pull the rope out. At the point where it becomes slightly harder to pull the rope, slowly allow the rope to recoil.

4. Pull the starter handle with a firm, rapid stroke. Do not release the handle and allow it to snap back. Keep a firm hold on the starter handle and allow it to slowly recoil.

5. As the engine warms, slowly rotate the choke control to the OFF position. If the engine falters, quickly rotate the choke control back to the FULL position and then slowly into the OFF position again.

NOTE: Allow the engine to warm up for a few minutes after starting. The engine will not develop full power until reaching operating temperatures.

Stop The Engine

Run engine for a few minutes before stopping to help dry off any moisture on the engine.

To help prevent possible starter freeze-up, proceed as follows:

1. Move throttle control to OFF position.
2. Remove the safety key (see Fig. 9) and store in a safe place.
3. Wipe all snow and moisture from the area around the engine as well as the area in and around the drive control and auger control. Also, engage and release both controls several times.



To Operate the Snow Blower

Auger Control

The auger control is located on the right handle. Squeeze the control grip against the handle to engage the augers and start snow throwing action. Release to stop. See Fig. 10.

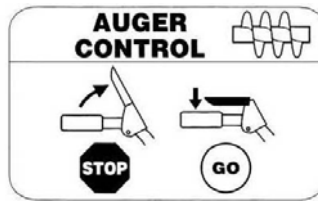

Fig. 10

Drive Control

The drive control is located on the left handle. Squeeze the control grip against the handle to engage the wheel drive. Release to stop. See Fig. 11.

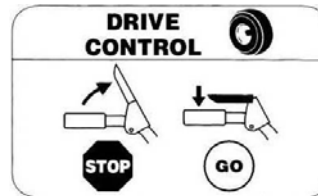

Fig. 11

To Engage Drive

1. With the throttle control in the Fast (rabbit) position, move shift lever into one of the four forward (F) positions or the reverse (R) position. Select a speed appropriate for the snow conditions and a pace you're comfortable with.

NOTE: When selecting a Drive Speed, use the slower speeds until you are comfortable and familiar with the operation of the snow thrower.

2. Squeeze the auger control against the handle and the auger will turn. Release it and the augers will stop.

3. Squeeze the drive control against the handle and snow thrower will move. Release it and drive motion will stop.

IMPORTANT: NEVER reposition the shift lever (change speeds or direction of travel) without first releasing the drive control and bringing the snow thrower to a complete stop. Doing so will result in premature wear to the snow thrower's drive system.

Chute Directional Control

The chute directional control is located on the panel of snow blower. Move handle Fig. 12-1 right & left to change the direction of snow out. Move handle Fig. 12-2 up & down to adjust the distance of snow throwing.

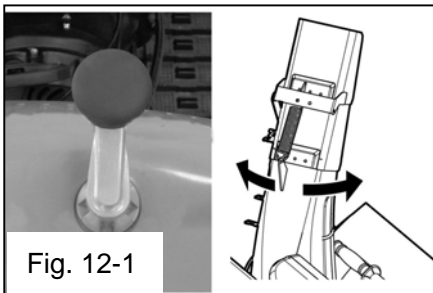

Fig. 12-1

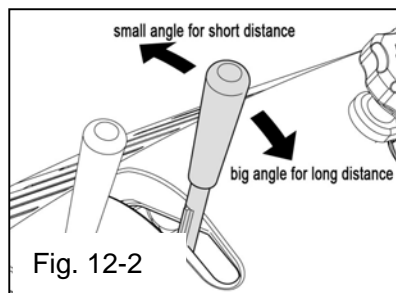

Fig. 12-2

3

Activate and Use



IMPORTANT

Refer to your Massimo Owner's Manual for any information relating to the use of your snow blower. These instructions are for assembly of your new accessory to further enhance your snow blower experience.

Specifications subject to change without notice or obligation

4

Service and Adjustment



IMPORTANT

Refer to your Massimo Owner's Manual for any information relating to the use of your snow blower. These instructions are for assembly of your new accessory to further enhance your snow blower experience.

Specifications subject to change without notice or obligation

Control Wire Adjustment

After long time using, or when the belts are adjusted or replaced, the control wires must also adjusted See Figure 13.

1. Lift the snow thrower forward and rest in on the auger housing.
2. Push the wire through the spring so that the threaded part is exposed.
3. Hold the threaded part and adjust the nut or until the correct setting is obtained.
4. Pull the wire through the spring again, Hook the wire into the upper part of the clutch lever same adjustment for both sides.

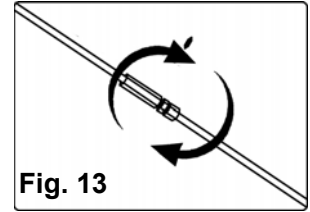

Fig. 13

Skid Shoe Adjustment

The space between skid shoes and the ground can be adjusted. See Figure 14.

- For close snow removal on a smooth surface, raise skid shoes higher on the auger housing.
- Use a middle or lower position when the area to be cleared is uneven, such as a gravel driveway.

To adjust the skid shoes:

1. Loosen the four hex nuts (Two on each side) and carriage bolts. Move skid shoes to desired position.
2. Make certain the entire bottom surface of skid shoe is against the ground to avoid uneven wear on the skid shoes.
3. Retighten nuts and bolts securely.

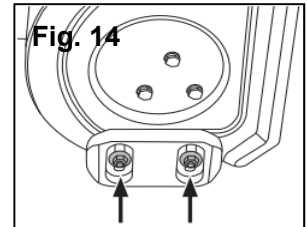

Fig. 14

Chute Bracket Adjustment

If the spiral at the bottom of the chute directional control is not fully engaged with the chute assembly, the chute bracket can be adjusted. To do so:

1. Loosen the two nuts which secure the chute brackets and reposition is slightly, See Figure 15.
2. Retightening the nuts. See Figure 15.

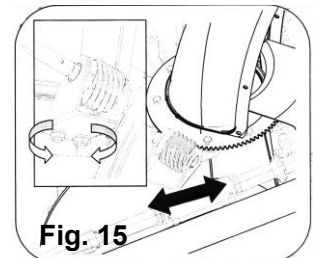

Fig. 15

Tire Pressure

Before operating, Check the pressure and reduce pressure to between 15 psi and 20 psi. If the tire pressure is not equal in both tires, the unit may pull to one side or the other.

Lubrication

WARNING: Before lubricating, repairing, or inspecting, disengage all controls and stop engine. Wait until all moving parts have come to a complete stop.

Gear Shaft

The gear (hex) shaft should be lubricated at least once a season or after every 25 hours of operation.

1. Remove the lower frame cover by removing the two screws which secure it.
2. Apply a light coating of an all-weather multi-purpose grease to the hex shaft. See Fig. 16.

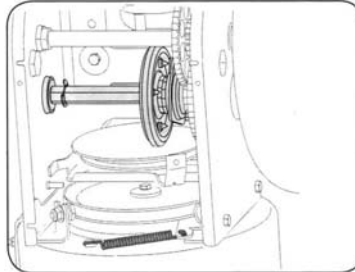

Fig. 16

IMPORTANT: Avoid oil spillage on rubber friction wheel and aluminum drive plate.

Wheels

At least once a season, remove both wheels. Clean and coat the axles with a multipurpose automotive grease before reinstalling wheels.

Chute Directional Control

Once a season, the joystick should be lubricated with petroleum jelly, Linseed oil, mineral oil, paraffin wax or 3-in 1 oil.

Auger Shaft

At least once a season, remove the shear pins on auger shaft. Spray lubricant inside shaft, around the spacers. Also lubricate the flange bearings found at either end of the shaft. See Fig.17.

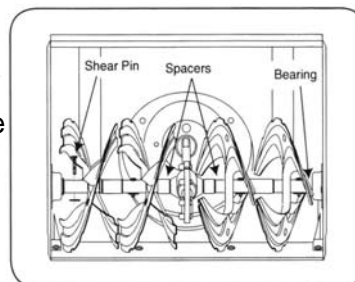

Fig. 17

Gear Case

The auger gear case has been filled with grease and sealed at the factory. If disassembled from any reason, lubricate with two ounces of new grease.

NOTE: Do not over fill the gear case. Damage to the seals could result.

5

Maintenance



IMPORTANT

Refer to your Massimo Owner's Manual for any information relating to the use of your snow blower. These instructions are for assembly of your new accessory to further enhance your snow blower experience.

Specifications subject to change without notice or obligation

5

Maintenance



IMPORTANT

Refer to your Massimo Owner's Manual for any information relating to the use of your snow blower. These instructions are for assembly of your new accessory to further enhance your snow blower experience.

Specifications subject to change without notice or obligation

Clean-Out Tool



WARNING: Never use your hands to clear a clogged chute assembly. Shut off engine and remain behind handles until all moving parts have stopped before unclogging.

The chute clean-out tool (see Fig. 18) is fastened to the top of the auger housing with a mounting clip. The tool is designed to clear a clogged chute assembly. Should snow and ice become clogged in the chute assembly during operation, proceed as follows to safely clean the chute assembly and chute opening.

1. Release both the Auger Control and the Drive Control.
2. Stop the engine by removing the ignition key.
3. Remove the clean-out tool from the clip which secures it to the rear of the auger housing. .

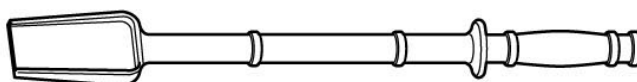

Fig. 18

Shave Plate and Skid Shoes

The shave plate and skid shoes on the bottom of the snow thrower are subject to wear. They should be checked periodically and replaced when necessary.

To remove skid shoes:

1. Remove the four carriage bolts and hex flange nuts which secure them to the snow thrower.
2. Reassemble new skid shoes with the four carriage bolts (two on each side) and hex flange nuts. See Figure 19.

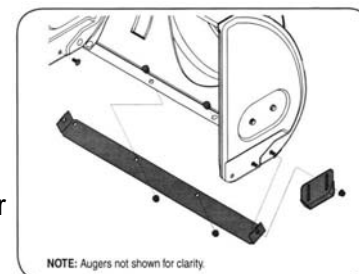

Fig. 19

To remove shave plate:

1. Remove the carriage bolts and hex nuts which attach it to the snow thrower housing.
2. Reassemble new shave plate, making sure heads of carriage bolts are to the inside of housing. Tighten securely. See Figure 19.

Augers

- The auger are secured to the spiral shaft with two shear pins and cotter pins. If the auger should strike a foreign object or ice jam, the snow thrower is designed so that the pins may shear. See Figure 13.
- If the augers will not turn, check to see if the pins have sheared. One set of replacement shear pins has been provided with the snow thrower. When replacing pins, spray an oil lubricant into shaft before inserting new pins.

Auger Belt Replacement

To remove and replace your snow thrower's auger belt, proceed as follows:

1. Remove the belt cover on the front of the engine by removing the two self-tapping screws.
2. **NOTE:** Drain the gasoline from the snow thrower, or place a piece of plastic under the gas cap. See Fig. 20.
3. Carefully pivot the snow thrower up and forward so that it rests on the auger housing. Remove the frame cover from the underside of the snow thrower by removing four self-tapping screws which secure it. See Figure 21.
4. Roll the auger belt off the engine pulley. See Figure 22.
5.
 - a. Loosen and remove the shoulder screw which acts as a belt keeper.
 - b. Unhook the support bracket spring from the frame. See Figure 23.
6. Remove the belt from the auger pulley, and slip the belt between the support bracket and auger pulley. Reassemble auger belt in reverse order as instructed above. See Fig. 24.
NOTE: Do NOT forget to reinstall the shoulder screw and reconnect the spring to the frame after installing a replacement auger belt.

Drive Belt Replacement

To remove and replace your snow thrower's auger belt, proceed as follows:

1. Do the 1st and 2nd step as shown in auger belt replacement.
2.
 - a. Grasp the idle pulley and pivot it towards right.
 - b. Roll the auger belt off the engine pulley.
 - c. Lift the drive belt off engine pulley. See Figure 25.
3. Slip the drive belt off the pulley and pull it out between friction wheel and friction wheel disc. See Figure 26.
4. Replace belt in reverse order as instructed above.

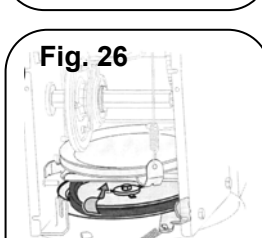
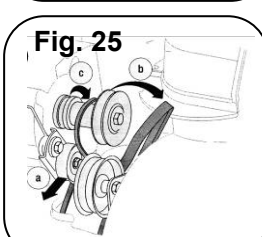
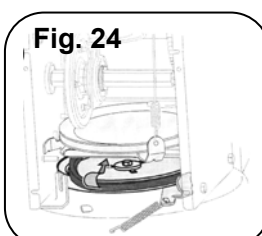
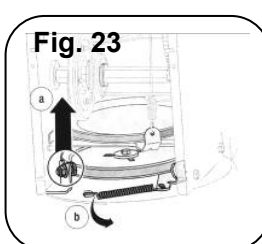
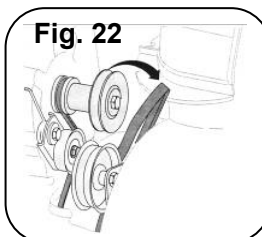
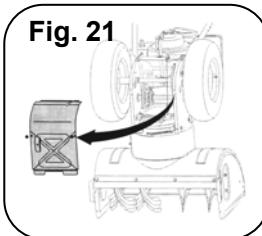
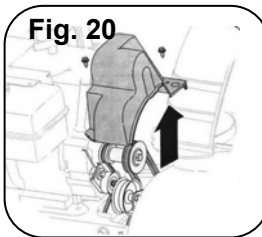

5

Maintenance



IMPORTANT

Refer to your Massimo Owner's Manual for any information relating to the use of your snow blower. These instructions are for assembly of your new accessory to further enhance your snow blower experience.

Specifications subject to change without notice or obligation

5

Maintenance



IMPORTANT

Refer to your Massimo Owner's Manual for any information relating to the use of your snow blower. These instructions are for assembly of your new accessory to further enhance your snow blower experience.

Specifications subject to change without notice or obligation

Friction Wheel Removal

If the snow blower fails to drive with the drive control engaged, and performing the drive control cable adjustment fails to correct the problem, the friction wheel may need to be replaced. Follow instructions below.

1. Examine the friction wheel for signs of wear or cracking and replace if necessary.

- Place the shift lever in third Forward (F3) position.

- Drain the gasoline from the snow thrower, or place a piece of plastic under the gas cap.

- Carefully pivot the snow thrower up and forward so that it rests on the auger housing

2. a. Remove the frame cover from the underside of the snow thrower by removing four self-tapping screws which secure it .

b. Remove the right-hand wheel by removing the screw and bell washer which secure it to the axle. See Figure 27.

3. Carefully remove the hex nut and washer which secures. See Figure 28. The hex shaft to the snow thrower frame and lightly tap the shaft's end to dislodge the ball bearing from the right side of the frame.

4. Pull the hex shaft out by force, remove the hex shaft and transition shaft assembly off. See Figure 28.

5. Remove the three screws which secure the friction wheel's side plates together, change the rubber ring only. See Figure 30.

6. Slide the friction wheel assembly back onto the hex shaft and follow the steps above in reverse order to reassemble components.

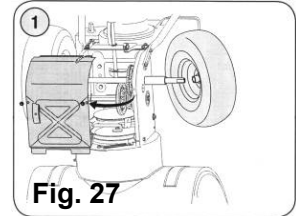

Fig. 27

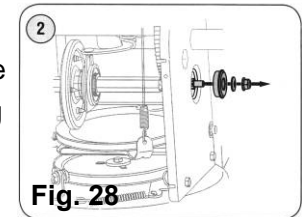

Fig. 28

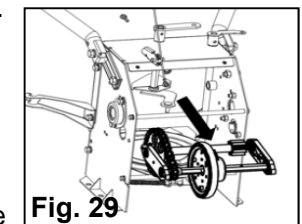

Fig. 29

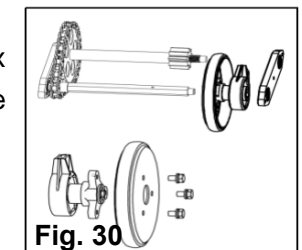

Fig. 30

Checking Spark Plug

Check spark plug yearly or every 100 operating hours

1. Clean area around spark plug.

2. Remove and inspect spark plug.

3. Replace spark plug if porcelain is cracked or if electrodes are pitted, burned or fouled with deposits.

4. Check electrode gap with a feeler gauge and set gap to 0.030(0.76mm) if necessary. See Figure 31.

5. Reinstall spark plug and tighten securely.

NOTE: A resistor spark plug must be used for replacement. Contact the distributor or local agent for a replacement spark plug.

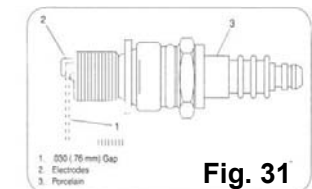

Fig. 31

Check Engine Oil

1. Be sure engine is upright and level.
2. Unscrew oil fill cap from oil filler tube and wipe dipstick clean. See Figure 32
3. Screw oil cap back into oil filler tube. Tighten securely.
4. Unscrew and remove oil fill cap from oil filler tube. Note oil level. If oil reading on dipstick is below “**LOW**” mark, slowly add oil to reach “**HIGH**” level. See Figure 33.
5. Screw oil fill cap back into oil filler tube, Tighten securely.
6. Wipe away any spilled oil.

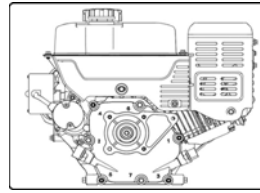

Fig. 32

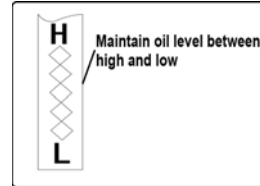

Fig. 33

Change Engine Oil

To avoid engine damage, it is important to:

- Check oil level before each use and every five operating hours.
 - Change oil after first two operating hours and every 25 operating hours thereafter.
 - Engine should still be warm but not hot from recent use.
1. Locate the oil drain plug, See Figure 38.
 2. Be sure the gas cap is on and is tighten securely.
 3. Clean area around oil drain plug, see Figure 38.
 4. Place approved recyclable oil container under oil drain plug.
 5. Remove oil drain plug and drain oil.

Note: Used oil must be disposed of at a proper collection center.

6. Install oil drain plug and tighten securely.
7. Refill the engine with recommended oil, see Recommended Oil Usage chart, the engine’s oil capacity is 26 ounces.
8. Wipe away any spilled oil.

Carburetor

If you suspect your carburetor needs adjusted, contact the distributor or local agent, engine performance should not be affected at altitudes up to 7000 feet (2135 meters). For operation at higher elevations, contact the distributor or local agent.

Engine Speed



WARNING: Avoid serious injury or death. DO NOT modify engine in any way. Tampering with the governor setting can cause the engine and equipment to operate at unsafe speeds. NEVER tamper with factory setting of engine governor. Running the engine faster than the speed set at the factory is dangerous.

5

Maintenance



IMPORTANT

Refer to your Massimo Owner’s Manual for any information relating to the use of your snow blower. These instructions are for assembly of your new accessory to further enhance your snow blower experience.

Specifications subject to change without notice or obligation

6

Off Season Storage



IMPORTANT

Refer to your Massimo Owner's Manual for any information relating to the use of your snow blower. These instructions are for assembly of your new accessory to further enhance your snow blower experience.

Specifications subject to change without notice or obligation

Preparing Engine



WARNING: Never store snow thrower with fuel in tank indoors or in poorly ventilated areas, where fuel fumes may reach an open flame, spark or pilot light as on a furnace, water heater, clothes dryer or gas appliance.

NOTE: It is important to prevent gum deposits from forming in essential fuel system parts of the engine such as the carburetor, fuel filter, fuel hose or tank during storage.

CAUTION: Alcohol blended fuels(called gasohol or using ethanol or methanol)can attract moisture which leads to separation and formation acids during storage. Acidic gas can damage the fuel system of an engine while in storage.

To avoid engine problems, the fuel system should be emptied before storage for 30 days or longer, Follow these instructions to prepare your snow thrower for storage:

WARNING: Drain fuel into an approved container outdoors, away from any open flame. Be certain engine is cool. Do not smoke. Fuel left in engine during warm weather deteriorates and will cause serious starting problems.



1. Remove ALL gasoline from the carburetor and the fuel tank to prevent gum deposits from forming on these parts and harming the engine.
2. Run the engine until the fuel tank is empty and it stops due to lack of fuel.
3. Drain carburetor by pressing upward on bowl drain, located below the carburetor cover.
4. Remove the spark plug and pour one ounce of engine oil through the spark hole into the cylinder. Cover spark plug hole with a rag and crank the engine several times to distribute the oil. Replace spark plug.

Preparing Snow Thrower

1. When storing the snow thrower in an unventilated or metal storage shed, care should be taken to rustproof the equipment, using a light oil or silicone,coat the equipment, especially any chains, springs, bearings and cables.
2. Remove all dirt from exterior of engine and equipment.
3. Follow lubrication recommendations in the Maintenance section of this manual.
4. Store equipment in a clean dry area.

NOTES:

*For parts, accessories or to find a dealer near you, visit:
www.MassimoMotor.com*