



CHIPPER ASSEMBLY GUIDE  
MODEL: OPC505AE  
5 INCH AUTO FEED CHIPPER



**DETAIL K2 INC.**

DK2 POWER USA  
4301 S Valley View Blvd STE 10-11  
Las Vegas, NV 89103  
1-702-331-5353

DETAIL K2, INC.  
1080 Clay Avenue Unit 2  
Burlington, Ontario, Canada L7L0A1

DK2 USA EAST  
6245 Industrial Parkway  
Whitehouse, OH 43571

**PARTS AND SERVICE 702-331-5353 OR [WWW.DK2POWER.COM](http://WWW.DK2POWER.COM) CONTACT US**

**5IN AUTO FEED CHIPPER**

AUTO FEED  
DOT TOWABLE  
KOHLER ENGINE



**OPC505AE 5 INCH  
AUTO FEED CHIPPER**

**STEP 1:**

Open and unpack all items. Leave lots of working space.  
Inspect all parts.

The CHIPPER is shipped in a crate. Remove all sides before you begin.

1. Assemble the main feed chute with the hinges and hardware provided.
2. Connect the wiring as shown.



NOTE: UPON INSPECTION OF PARTS IF YOU FIND ANY DAMAGE OR MISSING PARTS PLEASE CALL DK2 POWER AT **702-331-5353** OR CONTACT US VIA OUR WEBSITE [WWW.DK2POWER.COM](http://WWW.DK2POWER.COM)  
WE WILL REPLACE ANY MISSING PARTS TO YOU FREE

**PLEASE DO NOT RETURN TO THE STORE**

**STEP 2:**

1. Install the roller valve under the chute
2. Use 2 bolt hardware included.



**STEP 3:**

1. Install the feed roller speed control to side of chute.
2. TAKE CARE TO NOT DROP ANY HARDWARE INTO THE FEED CHUTE AND INTO THE CUTTING CHAMBER.

2 BOLTS AND NUTS



**STEP 4:**

1. INSTALL THE CHIP CHUTE
2. BOLT 4 PLACES

4 BOLTS on base



**STEP 5:**

1. INSTALL ENGINE GUARD
2. Use 4 bolts provided.

Use 4 bolts provided



1. Install the TOW BAR
2. Use 2 bolts and hardware provide and secure tightly

Use 2 bolts provided



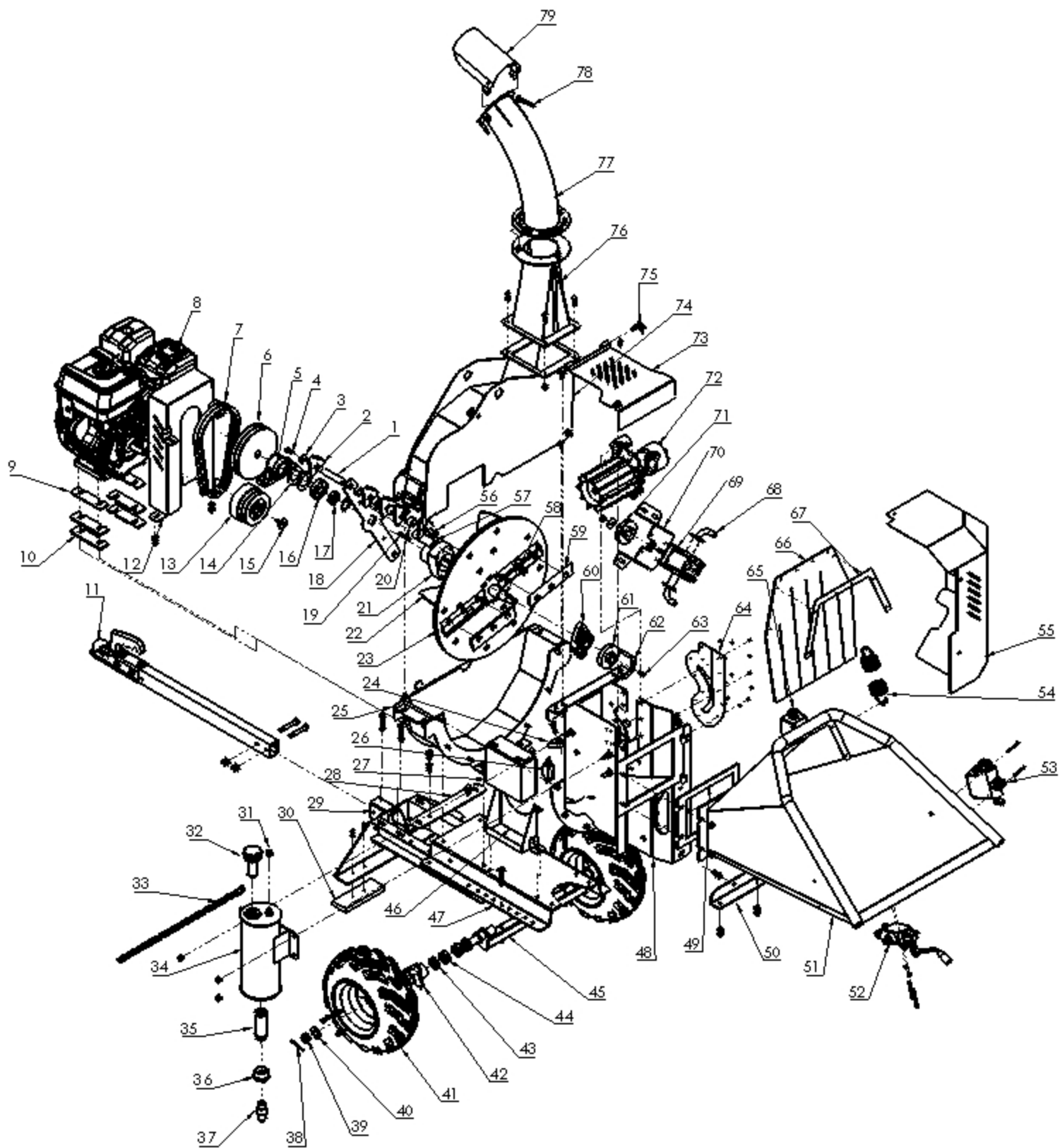



Ref.	Description	Ref.	Description
1	Penta-blade rod	41	Wheel 16*8.0-7
2	Triangle blade	42	Flange
3	Φ8 washer	43	Seal Φ25*47*7
4	M10*25 thinhead screw	44	Bearing6205
5	Bearing 1507	45	Wheel pipe axle
6	Pulley Φ200	46	Battery box
7	B-belt 940	47	Baseframe plate
8	Engine	48	Mouth frame
9	Adjust plate 4-0	49	Feed rubber
10	Adjust plat 8-0	50	Foot angle plate
11	Tow bar	51	Feed hopper
12	Belt cover	52	Switch valve
13	Clutch Φ125	53	Speed valve
14	Washer 2-0	54	Spring
15	M8*25 screw	55	Cover
16	Bearing 6306-2RS	56	Short blade spacer
17	Lock nut M35*1-5	57	Interval rod
18	Blade push-plate	58	Main axle
19	Key way 8*7*60	59	Plate blade
20	Long blade spacer	60	Bearing FL206
21	Bearing base	61	Pulley A Φ90
22	Fan plate	62	Belt A Φ500
23	Blade plate	63	Pin 8*7*30
24	Anvil	64	Rubber seal
25	Bottom frame	65	Emergency stop
26	Switch	66	Hopper block plate
27	Battery	67	Push bar
28	Cover fixing plate	68	Pump joint
29	Rear frame	69	Pump
30	Rubber pad	70	Pump fixing plate
31	Oil bean cover	71	Pump pulley
32	Oil feed filter	72	Ratchet & motor
33	Chain	73	Top cover
34	Tank	74	Top body
35	Oil outlet filter	75	Screw hook
36	1.5inch interface	76	Bottom discharge
37	Oil outlet interface	77	Top discharge
38	Pin Φ3.5*40	78	Fasten handle
39	Nut M24	79	Reflect cover
40	Φ25 washer		

READ THE KOHLER ENGINE MANUAL SUPPLIED WITH YOUR UNIT FOR FULL ENGINE OPERATION, SAFETY, AND MAINTENANCE.



YOUR UNIT HAS A COMMERCIAL KOHLER ENGINE WITH A 3YR PARTS AND SERVICE WARRANTY. FOR WARRANTY IN YOUR AREA CONTACT THE NEAREST KOHLER DEALER.

VISIT [WWW.KOHLERENGINES.COM](http://WWW.KOHLERENGINES.COM) FOR PARTS, SERVICE, MANUALS, AND DEALER LOCATIONS.

## OPERATION – BEFORE STARTING ENGINE

CLEAR AREA OF ALL PEOPLE AND PROPERTY THAT COULD BE DAMAGED. THINK SAFETY. THIS CHIPPER CAN CAUSE INJURY IF SAFETY IS NOT ENFORCED. ONLY ONE OPERATOR SHOULD WORK THIS UNIT. NEVER HAVE ANOTHER PERSON IN THE AREA OR IN FRONT OF THE CHIP EXIT CHUTE.

## IF YOUR UNIT WILL NOT START –

1. CHECK THE OIL LEVEL. YOUR ENGINE HAS A LOW OIL SHUTOFF PROTECTION AND WILL NOT START IF LOW ON OIL.
  2. MAKE SURE SPARK PLUG WIRE IS SEATED.
  3. MOVE THE GAS LEVER ON TO THE RIGHT. LEFT POSITION IS OFF.
  4. USE THE CHOKE IF NEED TO START IN COLD WEATHER.
  5. CHECK YOUR GAS LEVEL
- DO NOT WEAR LOOSE FITTING CLOTHES THAT COULD GET STUCK IN THE RAM
  - ONLY CHIP WOOD, NO METAL OR PLASTIC OR RUBBER. WOOD ONLY.
  - CHILDREN SHOULD NOT RUN THIS EQUIPMENT
  - STAY ALERT OF YOUR SURROUNDING AND PERSONS THAT COULD APEAR IN THE AREA WHILE YOU ARE WORKING.
  - LOAD TREES INTO FEED CHUTE. ADJUST FEED ROLLER TO SLOW FOR LARGER TREES AND FASTER FOR SMALLER TREES. USE LEVER IN CENTER OF FEED CHUTE TO CONTROL FORWARD/NUTRUAL/REVERSE OF FEED ROLLER.
  - IF ENGINE SPEED IS REDUCED WHEN CHIPPING ADJUST ROLLER SPEED.
  - WEAR SAFETY GLASSES, GLOVES AND PROTECTIVE SHOES.
  - OPERATE OUTDOORS ONLY – GAS FUMES ARE DEADLY INDOORS.

RUN ENGINE AT FULL RPM.

ALLOW MACHINE TO REGAIN RPM BETWEEN CHIPPING.

NEVER DISCONNECT SAFETY SWITCHES OR RUN WITH COVERS OPEN



## PLEASE DO NOT RETURN TO THE STORE

YOU HAVE A 1 YEAR WARRANTY AND DK2 WILL REPLACE A DEFECTIVE PART FOR FREE

**CALL US AT 702-331-5353 FOR FAST WARRANTY PARTS AND QUESTIONS**

### **WHAT IS COVERED**

DK2 Inc. warrants to the original purchaser of any DK2 product that it will be free and clear of manufacturing defects in workmanship and materials under normal use and service for a period of one (1) year from the date of the original purchase.

If within one (1) year from the original date of purchase this product fails due to defect in material or workmanship. DK2 POWER outdoor power equipment is 1-year parts only warranty no labor.

Upon expiry of one (1) year, Detail K2 will have no further liability related to the product. Detail K2 does not authorize any party, including its authorized distributors or dealers, to offer any other warranty on behalf of Detail K2 Inc.

KOHLER ENGINES – KOHLER CH SERIES ENGINES COMMERCIAL 3 YR PARTS AND LABOR WARRANTY

see your Kohler manual for specific warranty.

DIESEL TRACTORS – Chassis component parts only, no labor, ENGINES – 1 YR KOHLER WARRANTY

DK2 POWER OUTDOOR EQUIPMENT – 1-Year parts only, no labor.

THIS WARRANTY DOES NOT COVER OR APPLY TO:

Damage to the product due to misuse, mishandling and abuse

(b) Improper installation, maintenance and storage

(c) Expendable parts such as nuts and bolts, pins and springs, wiring and switch components, hydraulic hoses and fittings, cutting teeth, cutting chains, cutting blades, throttles, belts and tires.

(d) Normal wear and tear

(e) Consequential damage & incidental damages such as damage to persons or property

### **PROCEDURE FOR OBTAINING AN RETURN AUTHORIZATION**

Within the one (1) year warranty period, the purchaser of the product must notify DK2 of the claimed defect and provide proof of original purchase. At this time the validity of the claim will be determined, and if approved replacement parts will be issued.

No returned product will be accepted under warranty unless accompanied by an RGA# issued by Detail K2 Inc.

### **RESOLUTION FOR A DEFECTIVE PRODUCT**

DK2 POWER – Tractors, Chippers, Stump Grinders, Log Splitters, and Outdoor Power Equipment.

Call DK2 at **702-331-5353** in Las Vegas between 8am-4pm M-F Pacific Time.