

CARE TIPS

Cleaning Instruction: Clean with water and mild soap. Avoid harsh detergents. Dry completely.

Hutch Wood Care: To protect wood and increase durability, wood can be coated with a non-toxic outdoor paint or a water based sealant. For best results, re-coat yearly, especially in climates with extreme weather conditions.

Hutch Anchoring: Hutch, like all small outdoor sheds or structures, can be moved by heavy winds and storms. To provide additional stability to your hutch, use the techniques recommended for outdoor sheds.

WARNING:

Do not climb on the unit.

Children should not be allowed in, on or around the unit without proper supervision.

If any structural component is discovered to be broken or missing, stop the use of the product immediately.

Check hardware periodically to ensure screw/bolt tightness and security.

Keep hutch in safe area away from high winds and extreme temperatures.

Contact Us:

If you have any questions regarding your rabbit hutch, please feel free to contact our Customer Service Department at 1-877-PETMATE. We will be happy to assist you.

If you suspect a defect in material or workmanship, call our toll-free telephone number, 1-877-PETMATE or write to Duskocil Manufacturing Company, Inc., Customer Service, P.O. Box 1246, Arlington, Texas USA 76004-1246 to report defect to a customer service representative.

PRECISION™
PET PRODUCTS

RABBIT PLAYHOUSE
Rabbit Hutch

THIS BOX CONTAINS THESE PARTS:

FASTENERS

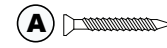

SCREWS
4x45mm
(Qty. 16)



SCREWS
4x20mm
(Qty. 14)



SCREWS
3x15mm
(Qty. 4)



SCREWS
4x30mm
(Qty. 8)

Contains one extra of each screw.

WOOD PIECES

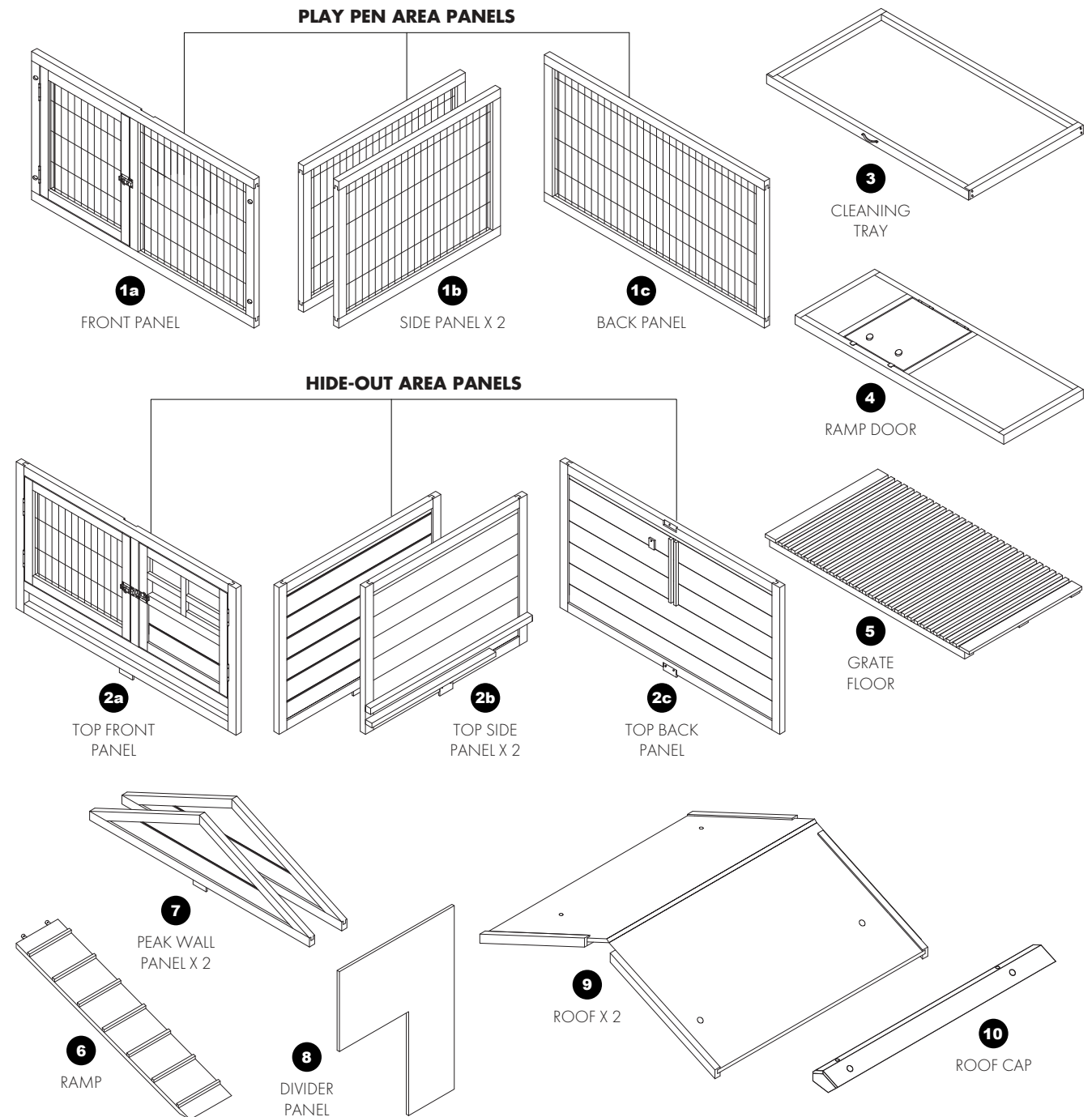

Assembly Instructions

*Use Screwdriver for Assembly

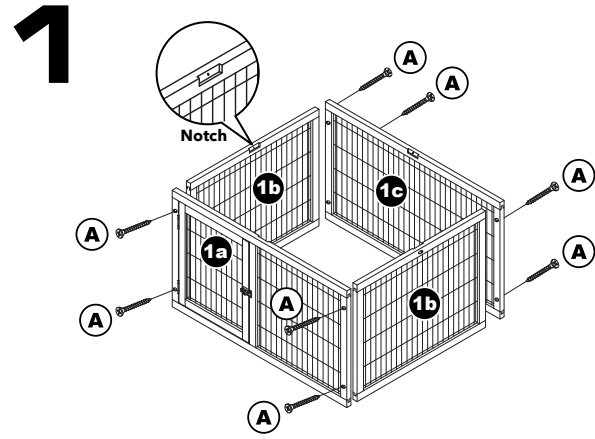

1. Connect Play Pen Area Panels (1a, 1b, 1c) with Screws (A).
Note: Make sure notches are on the inside of the hutch.

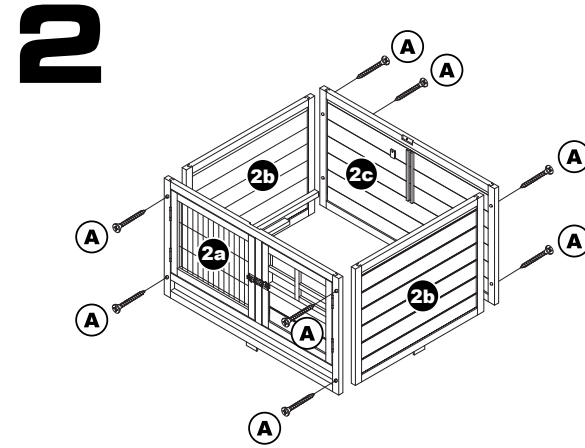

2. Connect Hide-Out Area Panels (2a, 2b, 2c) with Screws (A).

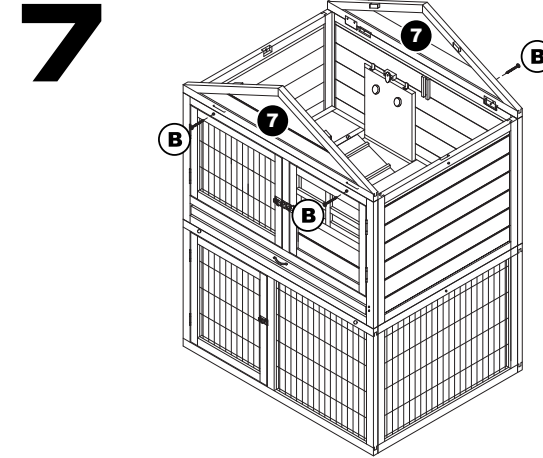

7. Connect Peak Wall Panels (7) with Screws (B).

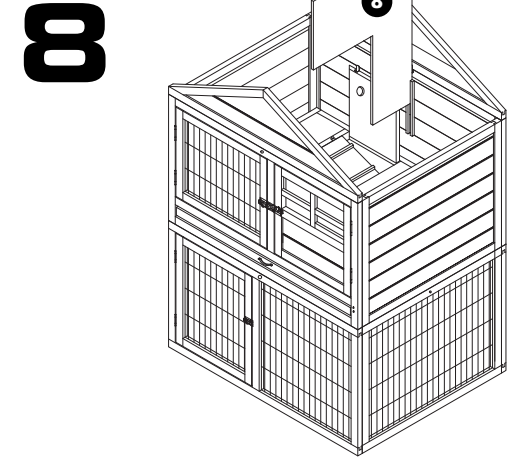

8. Insert Hutch Divider (8).

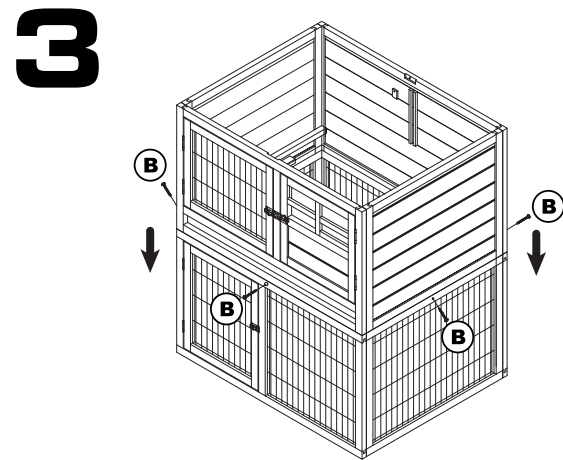

3. Connect Hide-Out Area to Play Pen Area with Screws (B).

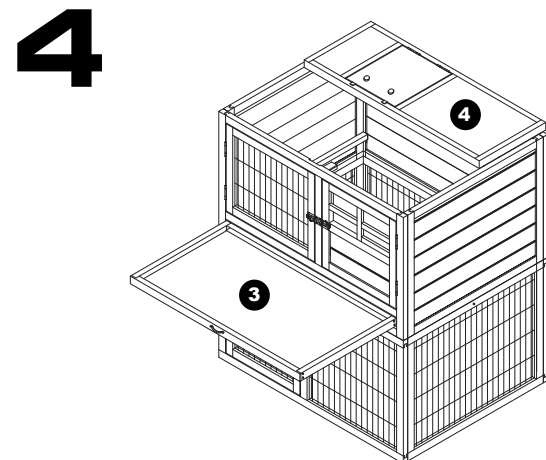

4. Insert Cleaning Tray (3) & Ramp Door (4).

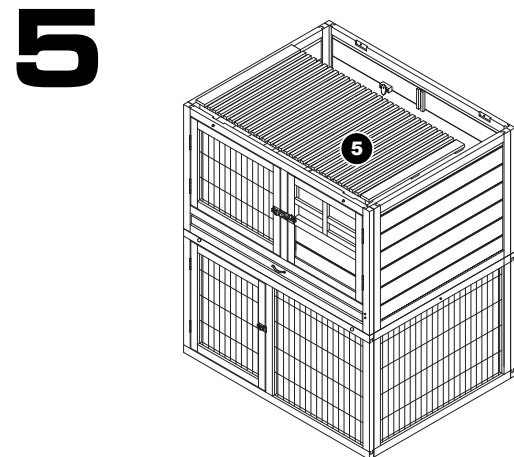

5. Insert Grate Floor (5).

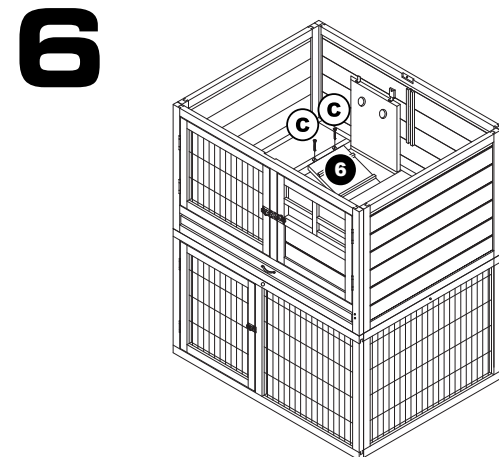

6. Open Ramp Door and Attach Ramp (6) with Screws (C).

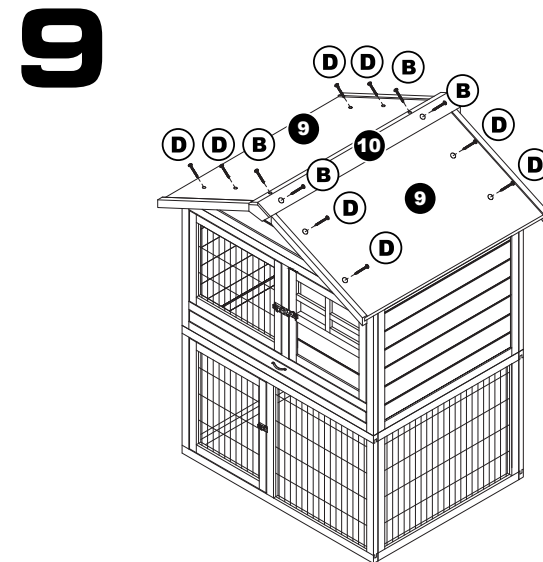

9. Attach Roof Panels (9) with Screws (D).
Attach Roof Cap (10) with Screws (B).