

CAROLINA FORGE

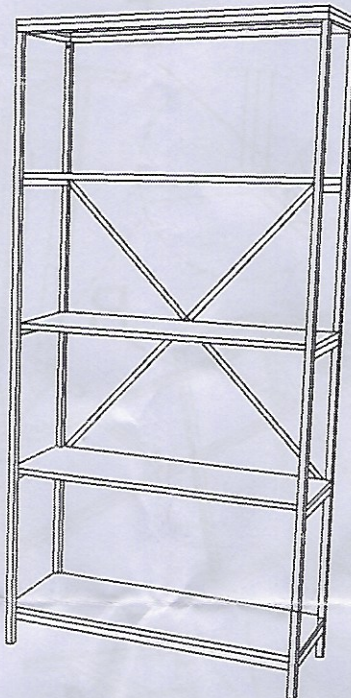









Assembly Instructions
 Item # CG7234
 CARLTON BOOKCASE



Please Note:
 Do not tighten screws
 completely until bookcase is
 fully assembled.



Thank you for purchasing a Carolina Forge Company product. This product has been designed for easy assembly and is constructed for durability. Please take the time to read and follow the assembly instructions carefully. If a part or hardware is missing or you have any difficulties in assembling this product, please contact us Toll Free 1-800-228-3876.

NO.	PART	DESCRIPTION	Q'TY	NO.	PARTS	DESCRIPTION	Q'TY
A		Top	1PC	B		Leg	2PCS
C		Shelf	4PCS	D		Connecting Tube	2PCS
E		Bolt 6mm 12mm	8 PCS	F		Allen Head Bolt M5x12	19PCS
J		Flat Washer	23PCS	K		Allen Head Wrench 3MM & 4MM	1PCS
L		Crosshead Screwdriver	PC	M		Allen Head Bolt M6x12	4PCS

Tool You Will Need (Not Supplied)

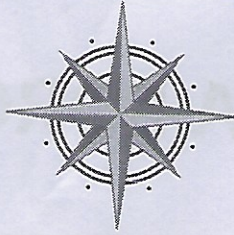

CAROLINA FORGE

Assembly Instructions
Item # CG7234
CARLTON BOOKCASE

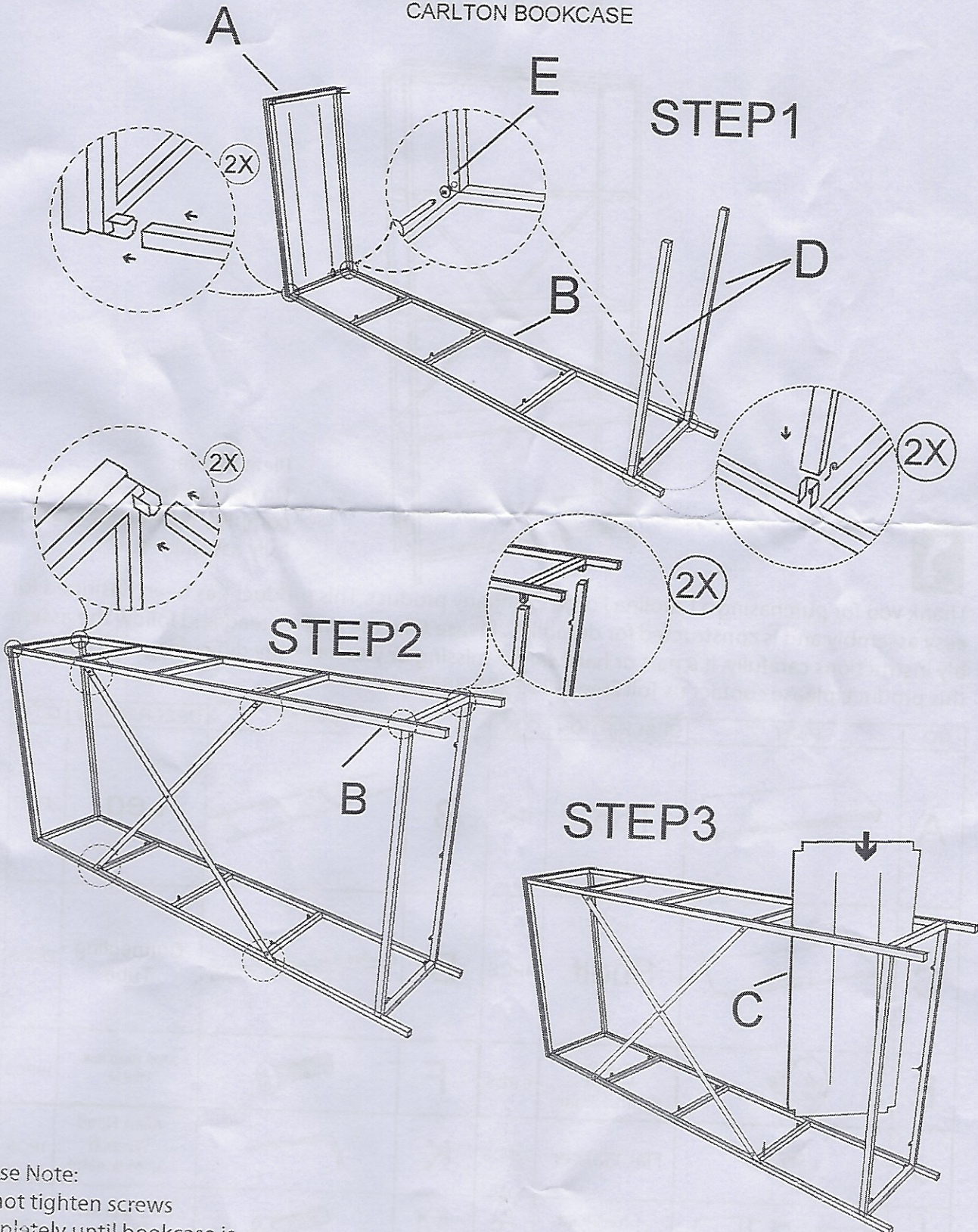

Please Note:
Do not tighten screws
completely until bookcase is
fully assembled.

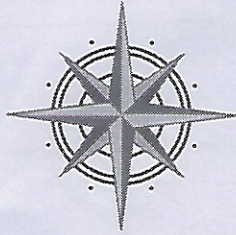

CAROLINA FORGE

Assembly Instructions

Item # CG7234

CARLTON BOOKCASE

STEP 4

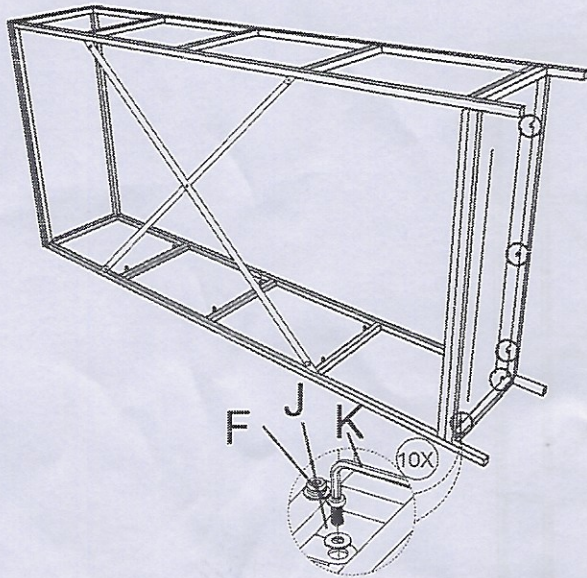

STEP 5

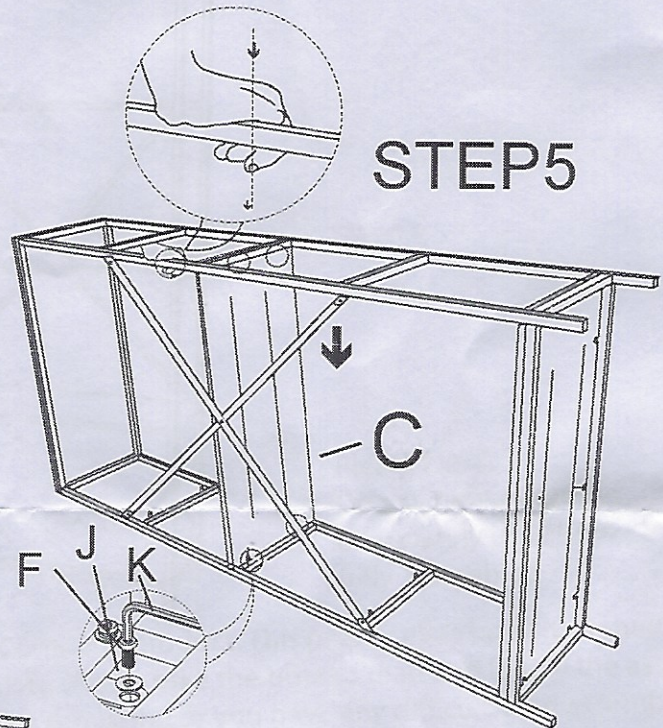

STEP 6

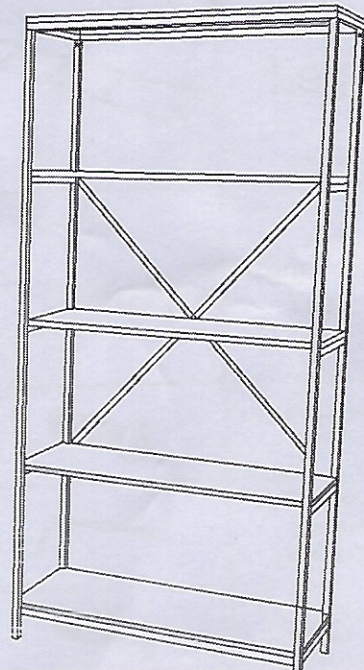
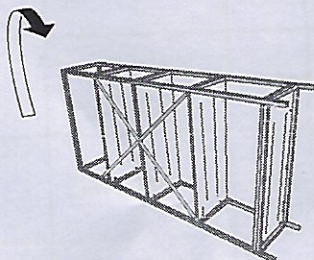
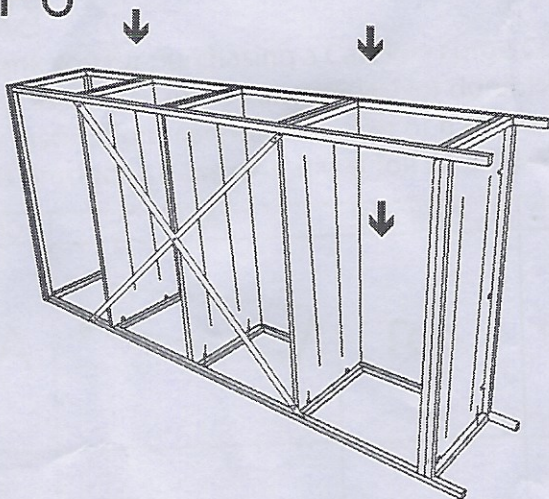

Please Note:
Do not tighten screws
completely until bookcase is
fully assembled.