



# ASSEMBLY INSTRUCTIONS

ITEM# FZR1474 & FZR1791

## PARTS LIST

	DESCRIPTION	Q' ty
A	Chair Back	1
B	Seat Frame	1
C	Right Leg	1
D	Left Leg	1
E	Right Arm	1
F	Left Arm	1
G	Stretchers	1

## HARDWARE LIST

NO.	DESCRIPTION	Q' ty
H	Screw $\Phi 5/16'' \times 3-1/4''L$	4
I	Screw $\Phi 5/16'' \times 2-1/2''L$	4
J	Screw $\Phi 5/16'' \times 1-3/4''L$	1
K	Screw $\Phi 1/4'' \times 3/4''L$	8
L	Screw $\Phi 1/4'' \times 1-3/4''L$	2
M	Flat Washer $\Phi 5/16'' \times 19mm$	9
N	Lock Washer $\Phi 5/16''$	9
O	Flat Washer $\Phi 1/4'' \times 16mm$	2
P	Lock Washer $\Phi 1/4''$	2
Q	Allen Wrench 5mm	1
R	Allen Wrench 4mm	1
S	Wood Screw #8*1-1/2"L	2
T	Connecting Metal 31*21*2mm	4

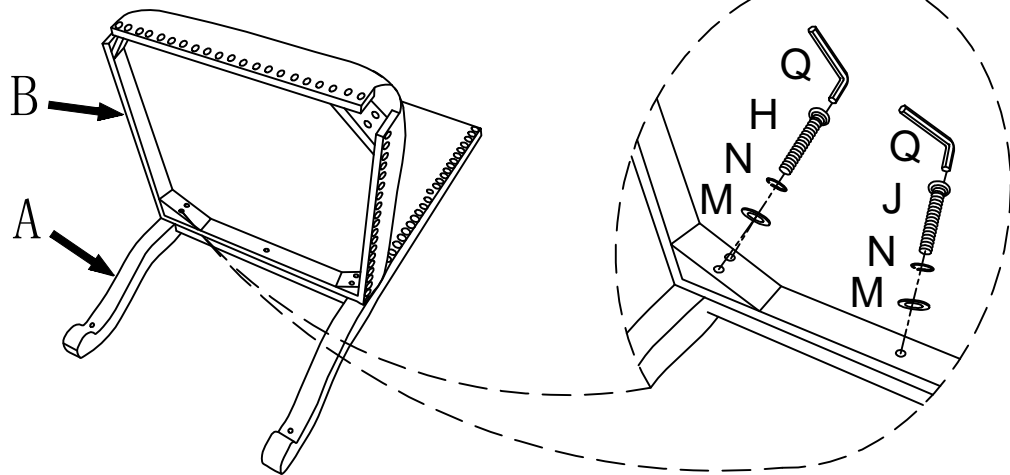
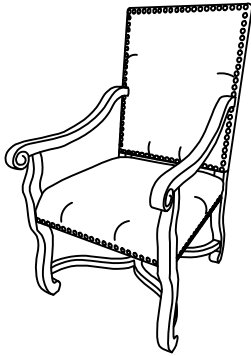

STEP1

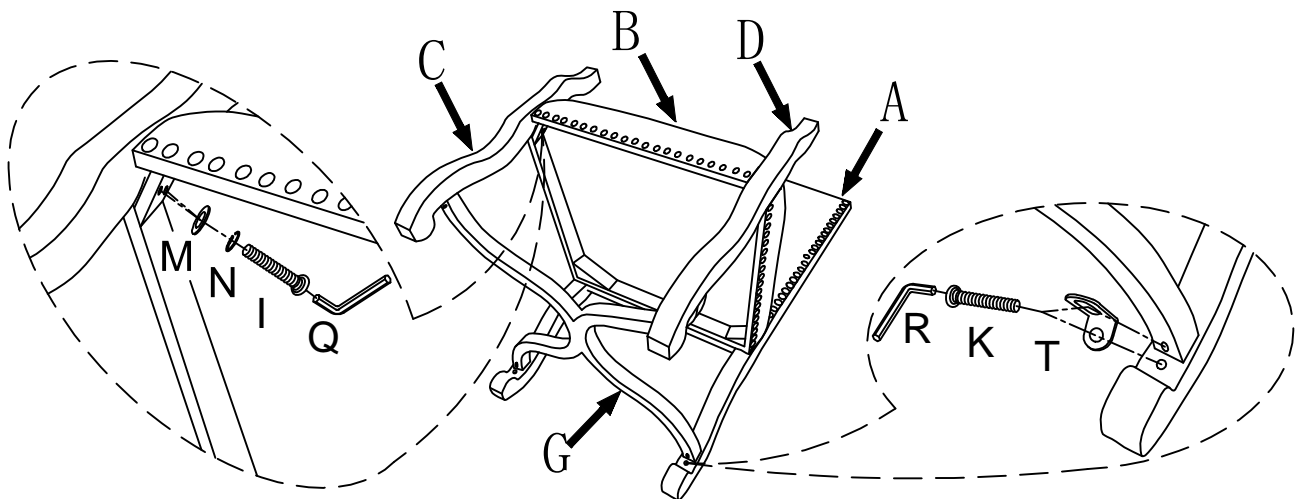

STEP2

Note:  
Lock the round hole first and  
then lock the elliptical hole !



# ASSEMBLY INSTRUCTIONS

ITEM# FZR1474 & FZR1791

PARTS LIST				HARDWARE LIST			
	DESCRIPTION		Q' ty	NO.	DESCRIPTION		Q' ty
A	Chair Back		1	H	Screw	$\Phi 5/16'' * 3-1/4''L$	4
B	Seat Frame		1	I	Screw	$\Phi 5/16'' * 2-1/2''L$	4
C	Right Leg		1	J	Screw	$\Phi 5/16'' * 1-3/4''L$	1
D	Left Leg		1	K	Screw	$\Phi 1/4'' * 3/4''L$	8
E	Right Arm		1	L	Screw	$\Phi 1/4'' * 1-3/4''L$	2
F	Left Arm		1	M	Flat Washer	$\Phi 5/16'' * 19mm$	9
G	Stretchers		1	N	Lock Washer	$\Phi 5/16''$	9
				O	Flat Washer	$\Phi 1/4'' * 16mm$	2
				P	Lock Washer	$\Phi 1/4''$	2
				Q	Allen Wrench	5mm	1
				R	Allen Wrench	4mm	1
				S	Wood Screw	#8*1-1/2''L	2
				T	Connecting Metal	31*21*2mm	4

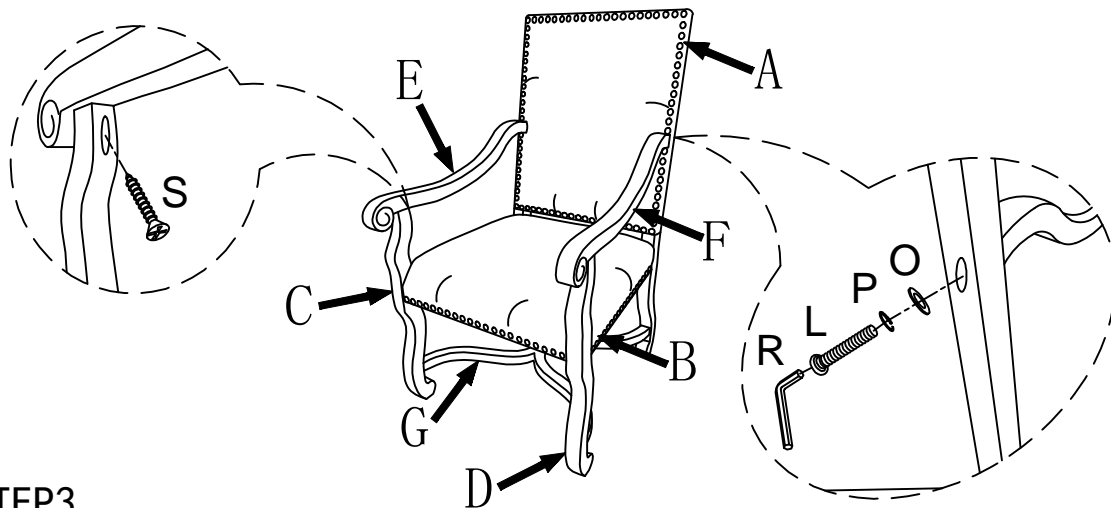
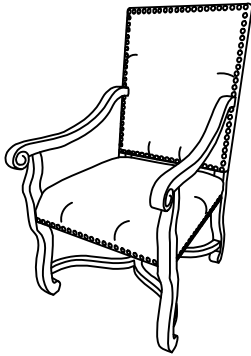

## STEP3

Note:  
Don't completely tighten  
all bolt until uprighted  
and leveled the chair !

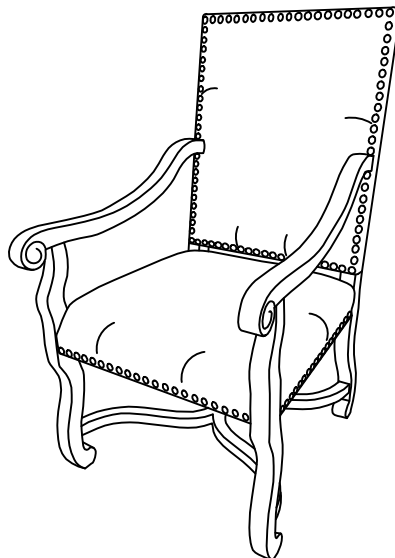

## FINISH