

POST HOLE DIGGER



OWNER'S MANUAL ASSEMBLY & OPERATING INSTRUCTIONS



WARNING: All operators must read this manual before operating this post hole digger. Follow the safety instructions in the manual and in decals attached to the product. Failure to do so could result in serious injury or death.

SAVE THESE INSTRUCTIONS FOR FUTURE REFERENCE

Table of Contents

Important Safety Information	3
Component Parts.....	7
Assembly Instructions	8
Operating Instructions	12
General Maintenance	13
Specifications	13
Parts Drawing & Parts List.....	14
Limited Warranty.....	17



IMPORTANT SAFETY INFORMATION



WARNING: Read and thoroughly understand all instructions and safety information before assembling or operating this post hole digger. Failure to do so may cause serious injury or death. Do not allow anyone to operate this post hole digger who has not read this manual. As with all power equipment a post hole digger can be dangerous if assembled or used improperly. Do not operate this post hole digger if you have doubts or questions concerning safe operation. Call our customer service department at (888) 723-6534 to address these concerns.

INTENDED USE

This product is designed to dig holes in the soil when attached to the 3-point linkage system and power-take-off a tractor. It is **not** intended for any other use. Using the product for anything other than digging holes could result in serious injury or death.

PERSONAL PROTECTIVE EQUIPMENT



ALWAYS use appropriate personal protective equipment such as protective eyewear and safety shoes when operating this post hole digger.

NEVER wear loose clothing or jewelry that could become entangled in the auger or driveline.

SAFETY DECALS

ALWAYS replace missing or defaced decals. Reorder from YTL or call 888-723-6534.

PROP 65 WARNING

This product contains chemicals known to the state of California to cause cancer, birth defects, or other reproductive harm.



IMPORTANT SAFETY INFORMATION



! DANGER

TO PREVENT SERIOUS INJURY OR DEATH:
Si no entiende ingles, se prefiere que busque a alguien que interprete las instrucciones para usted.

- Read and understand owner's manual before operating.
- Operate only from the tractor seat.
- Stay away from rotating parts. Keep others away.
- Do not dig around underground utility lines without checking with authorities.

! DANGER



Rotating Driveline
CONTACT CAN CAUSE DEATH
KEEP AWAY!

DO NOT OPERATE WITHOUT-

- All driveline guards, tractor and equipment shields in place
- Drivelines securely attached at both ends
- Driveline guards that turn freely on driveline

! DANGER

TO PREVENT SERIOUS INJURY OR DEATH:

- Contact dealer, make sure your machine has all current safety guards and shields in place.
- Do not operate without all guards and shields in place.
- Do not operate when auger is higher than 12 inches above ground level. Doing so may cause driveline to bind, resulting in equipment damage or operator injury.
- Stop auger rotation before maneuvering, relocating or transporting.

! WARNING

- This digger may not be compatible with all tractor models.
- Before operating, mount the boom and A-frame to the tractor.
- Raise up and lower the 3-point lift arms to the max and min positions.
- Check that there is no tractor/boom interference at any position.
- If there is not interference, continue with the assembly of the digger.
- Failure to do so may result in damage to the tractor, digger, and personal injury.

! DANGER

DO NOT ATTACH THIS IMPLEMENT OR ATTEMPT TO OPERATE UNTIL YOU HAVE READ AND UNDERSTOOD ALL INSTRUCTIONS IN THE OWNER'S MANUAL.



Know what's below.
Call before you dig.



IMPORTANT SAFETY INFORMATION



! DANGER		
	<p>Rotating Parts Hazard Keep Away</p> <p>To Prevent Serious Injury or Death from Rotating Parts:</p> <p><i>Si no entiende ingles, se prefiere que busque a alguien que interprete las instrucciones para usted.</i></p> <ul style="list-style-type: none"> • Read and understand owner's manual before operating. • Do not operate without all shields and guards in place. • Do not use body weight to force the auger into the ground or to locate auger point when auger is turning. • Keep away from auger, cutting head and driveline when engine is running. 	

! DANGER		
<p>GUARD MISSING When this is visible DO NOT OPERATE</p>		<p>KEEP CLEAR! Keep Others Away! ENTANGLEMENT HAZARD can cause Serious Injury or Death</p>
<p><i>Si no entiende ingles, se prefiere que busque a alguien que interprete las instrucciones para usted.</i></p> <ul style="list-style-type: none"> • Never manually position the auger or manually force the auger into ground. • This machine is designed to be operated ONLY from the tractor seat. • Keep everyone clear of all moving parts of the digger while in operation. 		

! DANGER

<p>GUARD MISSING DO NOT OPERATE</p>
! DANGER

<p>GUARD MISSING DO NOT OPERATE</p>

NOTICE
<p>540 RPM Maximum PTO Operating Speed</p>

NOTICE
<p>Gear box shipped without lubricant. Fill with 80W-90 lubricant before using.</p>



IMPORTANT SAFETY INFORMATION



GENERAL SAFETY AND PREPARATION

ALWAYS make sure that anyone else who operates this post hole digger has read and understood the contents of the owner's manual and all safety decals on the product.

ALWAYS be certain that all members of the work party are familiar with the operation of the digger and the hazards associated with it.

ALWAYS check with authorities for underground utilities before digging a hole. Serious injury or death could result from contact with gas or electric lines.

ALWAYS check the tractor owner's manual for instructions on operation, attachment of 3-point equipment and safety.

ALWAYS make sure that all safety shields are in place and tightened down. Do not operate this post hole digger if any shields are missing. Contact YTL at (888) 723-6534 or email at parts@ytlinternational.com for replacement parts.

ALWAYS make sure that the auger point and cutting edges are intact and in good working order before using this digger.

OPERATING SAFETY

ALWAYS operate this post hole digger from the tractor seat. Only one person should operate the digger.

NEVER attach the post hole digger with the tractor engine running.

NEVER operate the post hole digger with anyone near or in contact with any part of the implement, PTO driveline or auger. Serious injury or death could result from entanglement with moving parts.

ALWAYS make sure that the tractor brake is set before digging a hole.

ALWAYS keep hands, feet and clothing away from power-driven parts during operation.

NEVER manually position the auger or manually force the auger into the ground.

ALWAYS make sure that the tractor engine is shut off and the PTO drive is disengaged before leaving the tractor seat.

NEVER move the tractor with the power-take-off in the ON position.

NEVER exceed 540 RPM PTO operating speed.

NEVER operate the post hole digger when the auger point is more than 12 in. above ground level.

Operating the digger in elevated positions may cause the PTO driveline "U" joints to bind resulting in equipment damage and operator injury.

ALWAYS turn off the digger immediately if an immovable object is encountered to prevent damage to the gear box or driveshaft and possible injury. Driveline is protected by a shear bolt. If the shear bolt shears stop operating immediately to prevent further damage.

REPAIR AND MAINTENANCE SAFETY

ALWAYS perform maintenance operations such as lubrication, adjustments or repairs on the post hole digger with the tractor engine off, the PTO drive disengaged and the auger point resting on the ground.

ALWAYS use the correct shear bolt (Grade 5). **NEVER** use or replace the shear bolt with one that is longer than the one specified in the manual (5/16" x 3").

Periodically inspect all moving parts for wear and replace when necessary with authorized service parts. Look for loose fasteners, worn or broken parts, and leaky or loose fittings. Serious injury may occur from not maintaining this machine in good working order.

Do not modify or alter this Implement. Do not permit another to modify or alter this Implement, any of its components or any Implement function. Any modification will void the warranty.

TOOLS REQUIRED

- Allen Wrench 3
- 10mm, 14mm, 19mm, 22mm Wrenches
- Plier

Component Parts

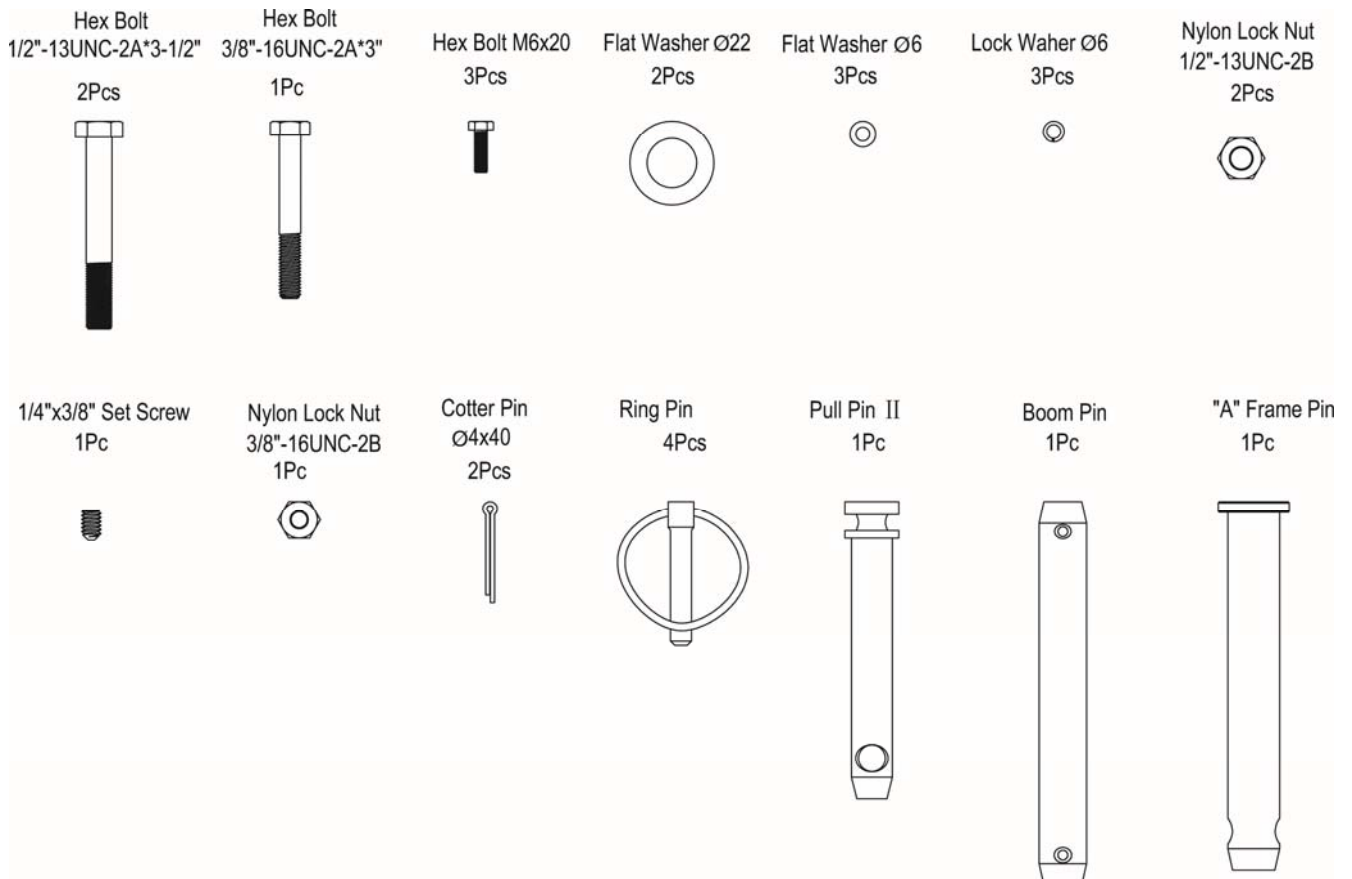

ASSEMBLY INSTRUCTIONS

IMPORTANT: The gear box is shipped without lubricant. Fill the top hole with 80W-90 lubricant or the equivalent. Fill until the lube appears at the side level check hole. Approximately two pints (32 ounces) of lubricant is required. Do not fill to overflow point as this may damage the seals.

STEP 1:

Be certain that the gear box has adequate lubrication. Check the oil level after every fifty hours of use.

STEP 2:

Pull out manual and hardware pack out from manual canister (13). Attach manual canister (13) on the boom (20) using hex bolt (10), lock washer (12) and flat washer (11). Put on rubber gasket (14), screw on Barrelhead (15) onto manual canister (13) and tighten.

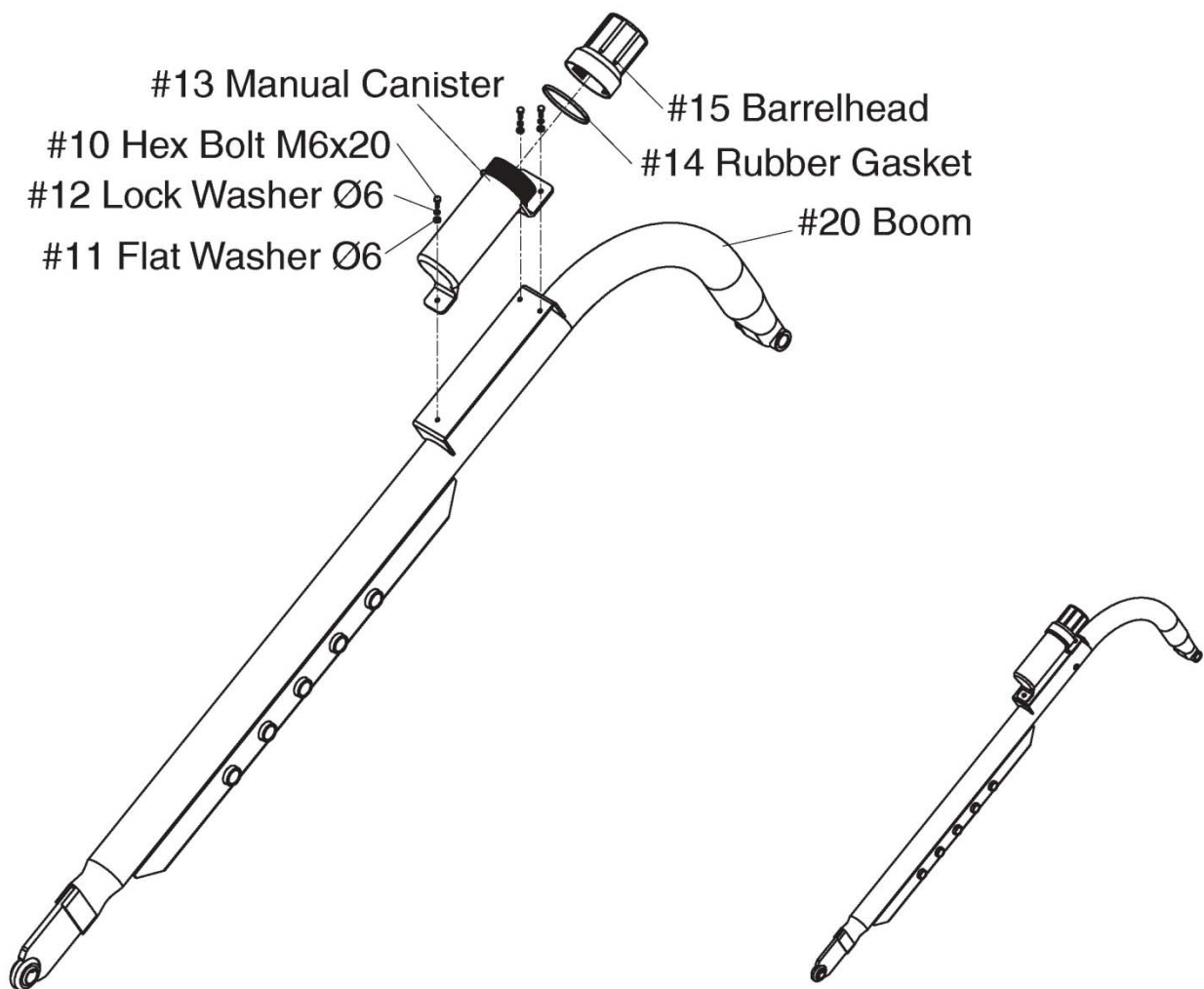

STEP 3:

Connect the “A” frame (6) to the tractor’s 3-point lift arms using the 7/8 in. draw pin with nut and washers as shown in the drawing. For Category 1 tractors (lift arm spacing of 26 in.), use the pins in the inward position. For Category 2 tractors (lift arm spacing of 32 in.), the pins should point outwards. Attach the “A” frame pin (7) to the boom (20) after selecting the desired hole (for angle adjustment) using the “A” frame pin (7) and lynch pin (1).

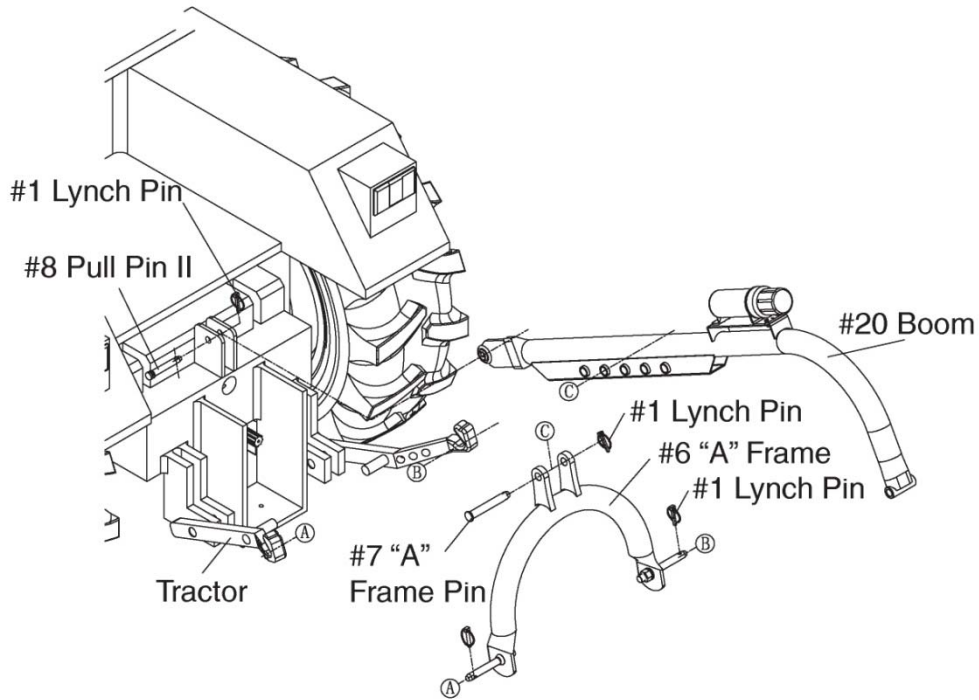

STEP 4:

Attach the gear box (21) to the boom (20) using the boom pin (22). When in place secure with flat washers (5) and cotter pins (23).

NOTE: Input shaft shield (19) and output shaft shield (24) are already attached to the gear box.

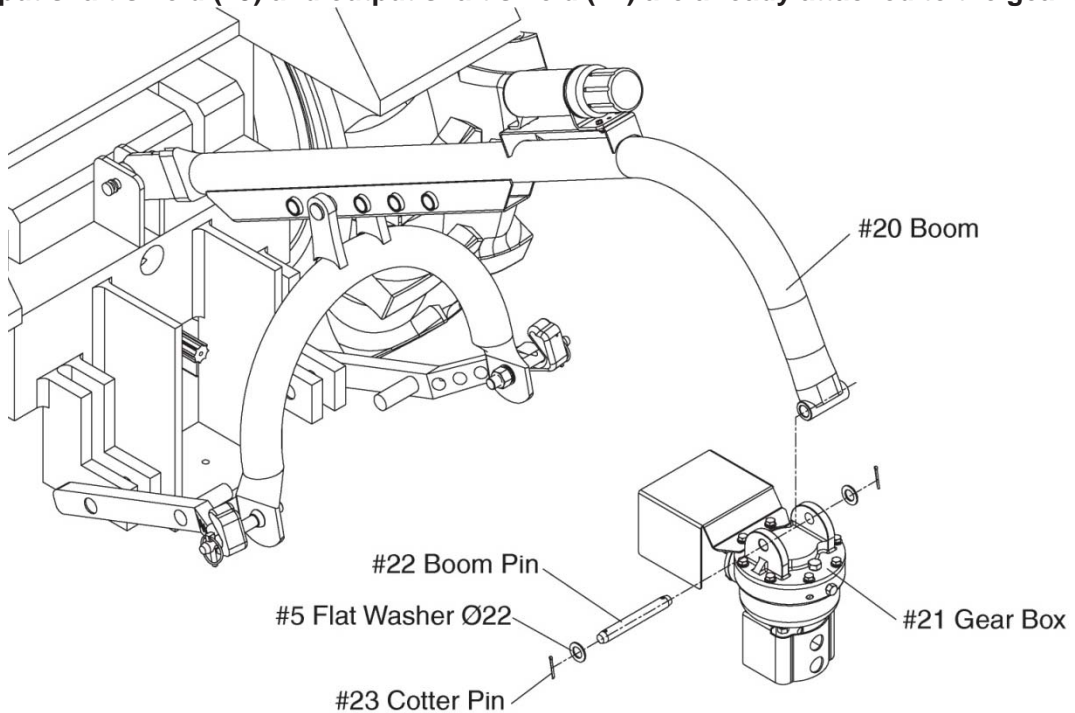

STEP 5:

Attach the auger (30) to the output shaft on the bottom of the gear box (21) using the Hex bolts 1/2"-13UNC-2A*3-1/2" (26) and nylon lock nuts 1/2"-13UNC-2B (27). Tighten the nuts.

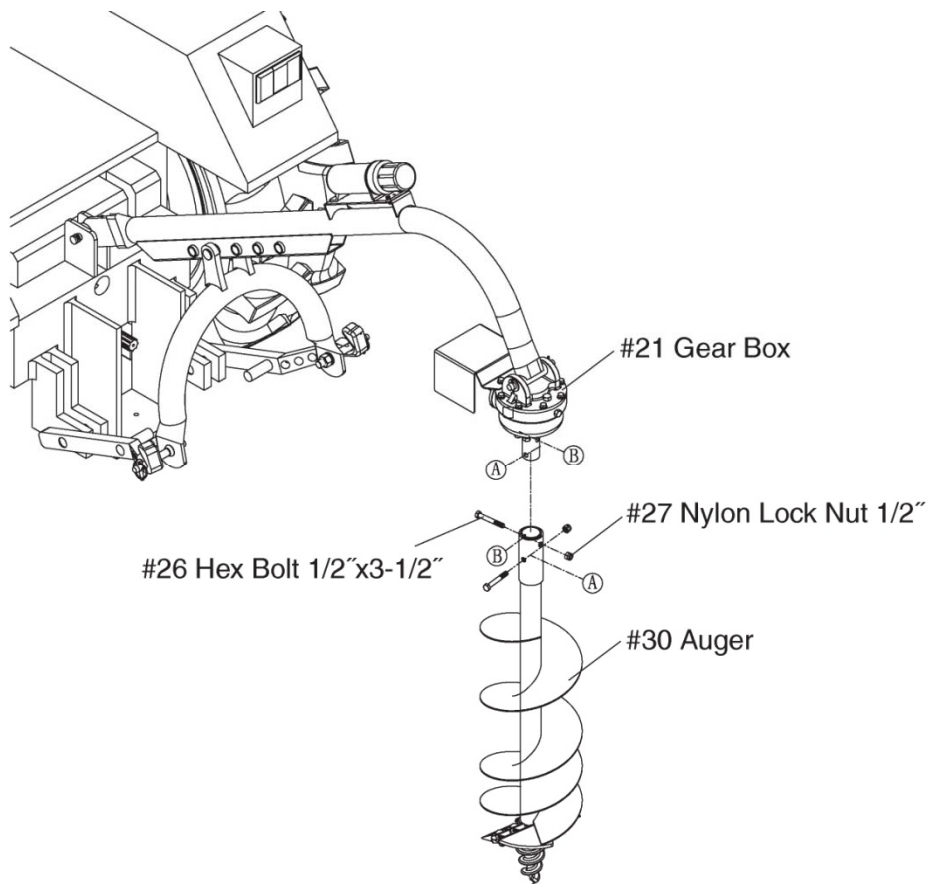

STEP 6:

Attach the driveline (9) to the gear box input shaft using the hex bolt 3/8"-16UNC-2A*3" (28) and the nylon lock nut 3/8"-16UNC-2B (29). Tighten the nut. Insert the 1/4"x 3/8" set screw (#31) in the hole on the yoke that aligns with the 3/16" groove on the gear box input shaft. Tighten loosely.

ATTENTION:

THE HEX BOLT 3/8"-16UNC-2A*3" PROVIDES SHEAR PROTECTION. USE A GRADE 5/16x 3" BOLT ONLY TO AVOID DAMAGE TO THE GEAR BOX OR AUGER.

IMPORTANT: The universal joint should be greased with a good grade chassis lube approximately every 6 months. At the beginning of each season grease the sliding driveshaft members with a moly grease. All diggers are equipped with quick-detach universal joints on the power-take-off end for a 1-3/8 in. splined shaft.

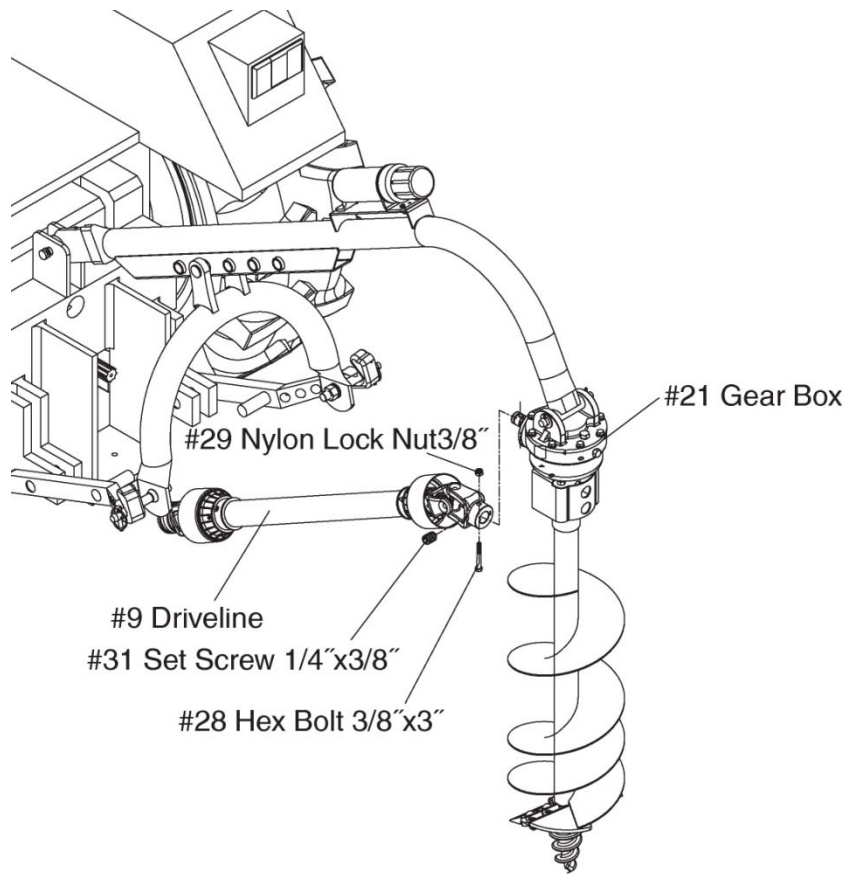

STEP 7:

Attach the tractor end of the driveline (9) to the tractor PTO shaft. Retract the yellow zinc plated outer collar and slip it on the splined PTO shaft of the tractor. Release the collar when it is securely in place on the shaft. Note: Driveline has 1-3/8x6 splined for tractor end. PTO adaptors or extenders are not recommended.

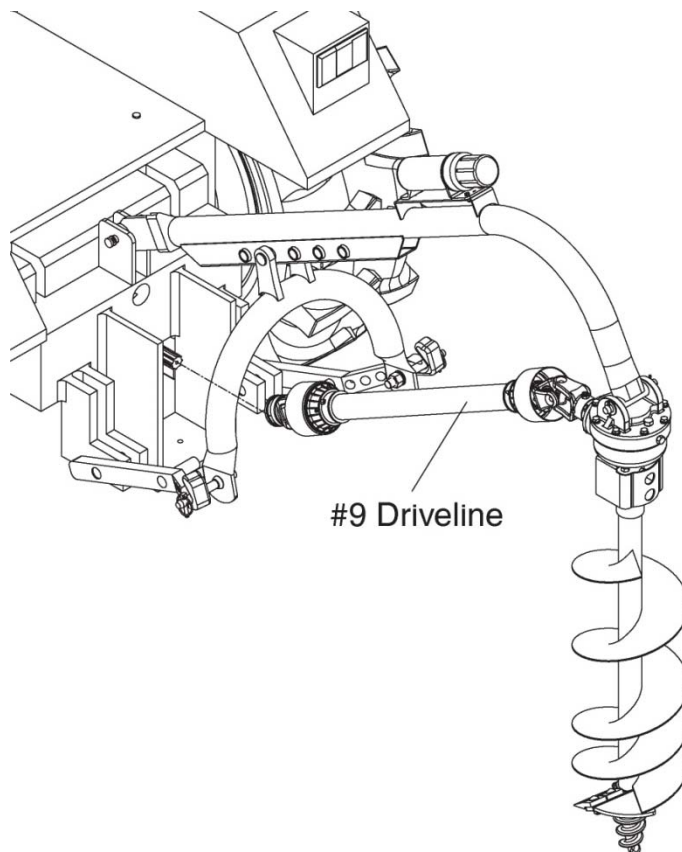

STEP 8:

Check all nuts and bolts for tightness. Stabilizers should be kept tight to avoid side sway of the digger.

NOTE: See illustration A for reference in assembling the digger and mounting it to the tractor. Note that the boom angle can be adjusted on your tractor for proper digging and ground clearance by moving the “A” frame to a different mounting hole as shown in illustration B.

NOTE: When the 7/8 in. diameter draw pins in the “A” frame are too small for the holes in the lift arms a Cat 1 to Cat 2 draw pin can be substituted or bushings should be used to obtain the proper fit.



ILLUSTRATION A



ILLUSTRATION B

OPERATING INSTRUCTIONS



WARNING: Read and thoroughly understand all instructions and safety information before operating this post hole digger. Failure to do so may cause serious injury or death. Do not allow anyone to operate this post hole digger who has not read this manual.

STEP 1:

After mounting the digger to the tractor, lower the auger point slowly to the ground at the desired digging angle before engaging power.

STEP 2:

Engage the power-take-off and start digging at a slow speed, lowering the auger slowly as it begins to dig.

STEP 3:

Increase speed as the auger goes deeper. The type of soil will determine the proper auger speed. If the soil is extremely hard, it will generally improve operation to vary the speed of the auger at times.

STEP 4:

When the auger has reached the desired depth, spin it momentarily at a high speed to clear the hole of dirt. Reduce speed before withdrawing the auger from the hole.

STEP 5:

Disengage the power-take-off after withdrawing from the hole and move the tractor to the next hole location.

GENERAL MAINTENANCE



WARNING: Always perform maintenance operations with the tractor engine off, the PTO drive disengaged and the auger point resting on the ground.

1. To remove the auger from the gear box output shaft, remove the two hex bolts 1/2"-13UNC-2A*3-1/2" (26).
2. To remove the driveshaft from the gear box input shaft, remove the hex bolt 3/8"-16UNC-2A*3" (28).
3. Check the oil level after every fifty hours of use. Use 80W-90 lubricant and fill to oil level plug. All replacement lubricant should be of this type.
4. The universal joints should be greased with a good grade chassis lube every week. At the beginning of each season, grease the sliding driveshaft members with a moly grease.

SPECIFICATIONS

Tractor Category.....Category 1 or Category 2
 Gear Box..... Special alloy pinion gears and tapered roller bearings on both sides of each gear
 Driveline.....Series 4 equipped with quick-latch yoke to fit standard 6-spline PTO (completely shielded)
 Augers..... Sold separately. 6 in.,9 in. and12 in. sizes available
 Cutting Edges..... Replaceable High Carbon Steel
 Point..... Replaceable Spiral tip
 Boom.....3 in. O.D. high strength tubing
 A-frame.....3 in. O.D. high strength tubing
 Safety shields..... On driveline, gear box "U" joint and gear box output shaft
 Shear Pin..... Replaceable. On input shaft to protect driveline, auger and gears

DIGGER PARTS DRAWING & PARTS LIST

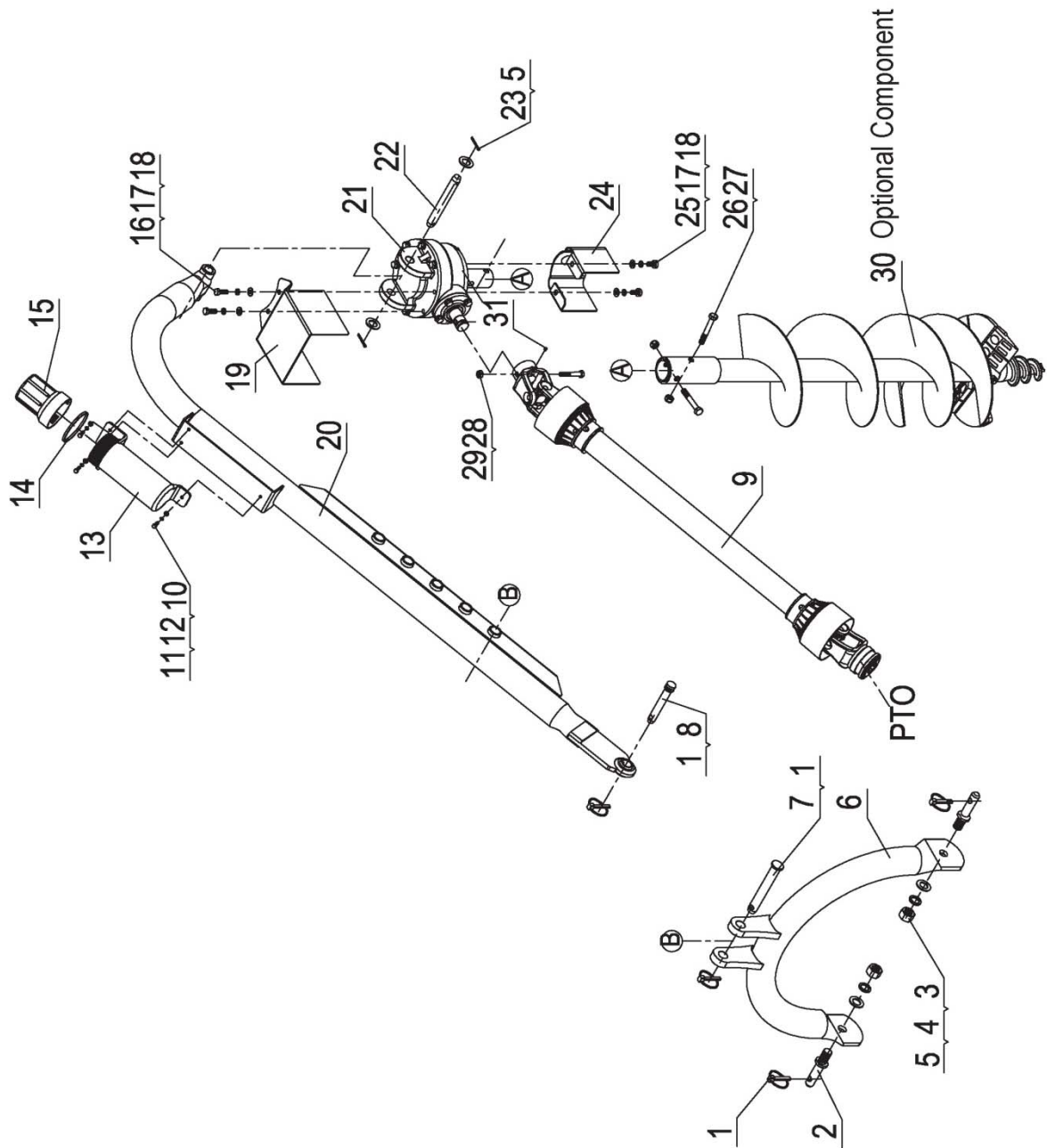

DIGGER PARTS DRAWING & PARTS LIST

Ref#	Drawing No.	Description	Qty
1	Z120-00003-CD	Lynch Pin	4
2	TS2400-00001-CD	Pull Pin I	2
3	YZ01-22000-CD	Hex Nut 7/8"-14UN-2B	2
4	9306-22000-CD	Lock Washer Ø22	2
5	9301-22000-CD	Flat Washer Ø22	4
6	TS2401-01000	"A" Frame	1
7	TS2401-00001-CD	"A" Frame Pin	1
8	N800-00004-CD	Pull Pin II	1
9	TS2400-04000	Driveline	1
10	9101-06020-CD	Hex Bolt M6x20	3
11	9301-06000-CD	Flat Washer Ø6	3
12	9306-06000-CD	Lock Washer Ø6	3
13	LSP30MD-02001	Manual Canister	1
14	LSP30MD-02002	Rubber Gasket	1
15	LSP30MD-02003	Barrelhead	1
16	9101-10030-CD8.8	Hex Bolt M10x30	2
17	9306-10000-CD	Lock Washer Ø10	4
18	9301-10000-CD	Flat Washer Ø10	4
19	TS2400-03010	Input Shaft Shield	1
20	TS2401-02000	Boom	1
21	TS2400-03000	Gear Box	1
22	TS2400-00003-CD	Boom Pin	1
23	9404-04040-CD	Cotter Pin Ø4x40	2
24	TS2400-03011	Output Shaft Shield	1
25	9104-10020-CD8.8	Inner Hex Flat Screw M10x20	2
26	YZ01-1/2"-13UNC-2A*3-1/2"-CD8.8	Hex Bolt 1/2"-13UNC-2A*3-1/2"	2
27	YZ06-12000-CD	Nylon Lock Nut 1/2"-13UNC-2B	2
28	YZ01-3/8"-16UNC-2A*3"-CD8.8	Hex Bolt 3/8"-16UNC-2A*3"	1
29	YZ06-10000-CD	Nylon Lock Nut 3/8"-16UNC-2B	1
30	Optional auger	Please go ordering information for choice	/
31	YZ09-1/4"-20UNC-2A*3/8"-FH8.8	Set Screw 1/4"-20UNC-2A*3/8"	1

ORDERING INFORMATION

PART NO.	DESCRIPTION
YTL-017-787	6" auger with spiral point and replaceable carbide cutting edges
YTL-017-794	9" auger with spiral point and replaceable carbide cutting edges
YTL-017-800	12" auger with spiral point and replaceable carbide cutting edges

CUTTING EDGES, SPIRAL POINT DRAWING & PARTS LIST

Number of Cutting Edges Per Auger

6" (YTL-017-787) - 2

9" (YTL-017-794) - 2

12" (YTL-017-800) - 4

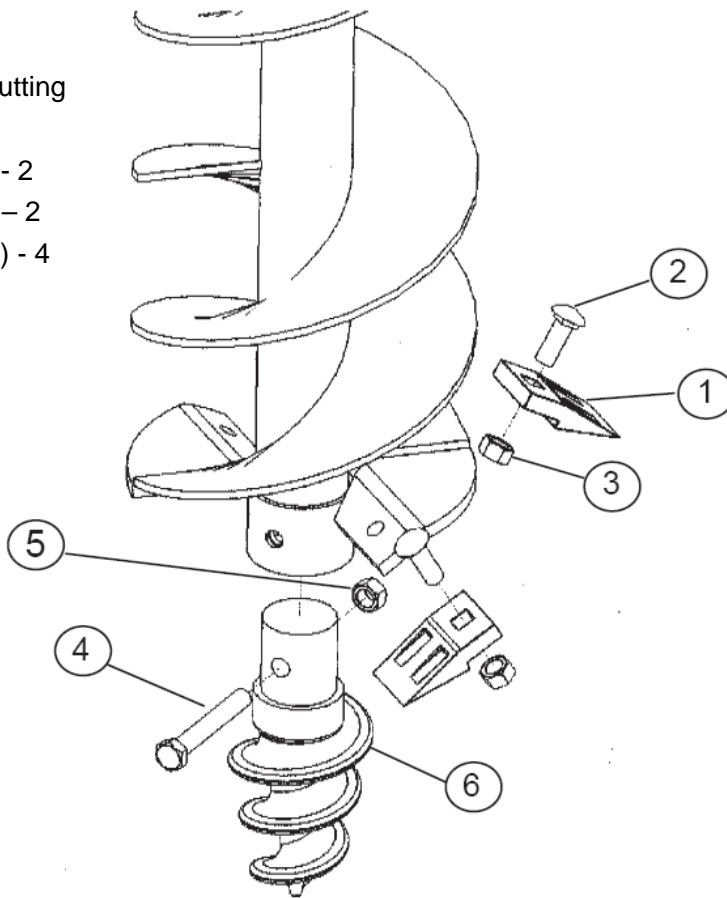

NOTE: It is important to replace the point and cutting edges when they show signs of excessive wear.

REF. NO	DESCRIPTION	QTY
1	Carbide Cutting Edge	Varies by auger
2	1/2"x 1" UNC Carriage Bolt	1 per cutting edge
3	1/2" UNC Lock Nut	1 per cutting edge
4	1/2"x3-1/2" Bolt	1
5	1/2" Lock Nut	1
6	Spiral Point	1

NOTE: The number of cutting edges varies by auger size. Check your auger when ordering replacement cutting edges.

LIMITED WARRANTY

For 1 year from the date of purchase YTL International will replace or repair defects in material and workmanship, the gear box has a three warranty for the original purchaser of the digger. The warranty will not apply to any unit which was not assembled correctly, misused, overloaded or which has been used or operated contrary to our instructions, or which has been repaired or altered by anyone other than a service representative authorized by YTL International Inc.

Warranty Exclusions

This warranty does not cover cosmetic defects such as paint, decals or wear items This warranty will not cover failures or problems due to acts of God, or events or forces beyond the control of the manufacturer.

Normal Wear Exclusion

The digger needs periodic service to perform well. This warranty does not cover repair when normal use has exhausted the life of a part or the equipment as a whole.

Installation, Use and Maintenance Exclusion

This warranty will not apply to parts and/or labor if the digger has been misused, neglected, involved in an accident, abused, loaded beyond its limits, modified or assembled incorrectly. Normal maintenance is not covered under this warranty.

Contact Information

YTL International Inc.
17517 Fabrica Way Suite H
Cerritos, CA 90703
Phone: (888) 723-6534 or (562) 404-8016
Fax: (562) 404-8013
Website: www.ytlinternational.com

Contact Information below for Warranty and Service

Parts and Service:

Toll Free (888) 723-6534 (USA & Canada)

Email: parts@ytlinternational.com