

# **4 DC EDMONTON KITCHEN CARTS**

**MODEL: 43929 / 43029**

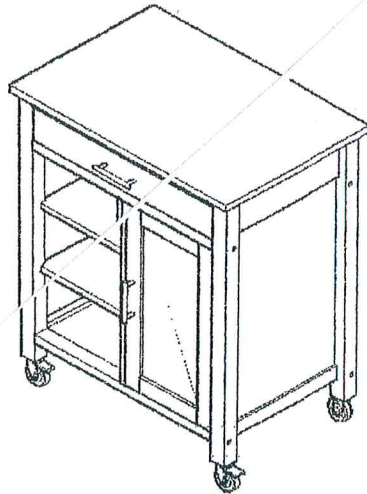

## **NEED ASSISTANCE?**

Call 4D CONCEPTS directly for parts or assembly assistance.

Individual stores do not stock parts

Call our Toll-free number 5 days a week excepts holidays:

Monday through Friday 8.00am to 5.00pm

Pacific Standard Time

**1-888-310-4DCO or 1-888-310 4326**

**IMPORTANT:** Before calling please have the model number and the packing code number ready for our customer service representatives.

You will find the model number printed on the carton label and the packing code printed in black ink on the side of the carton.

Model      43929                  Packing code

It is important that you retain the model number and the packing code along with the original receipt of purchase for future reference.

Made in Malaysia

# 43929 ASSEMBLY INSTRUCTION

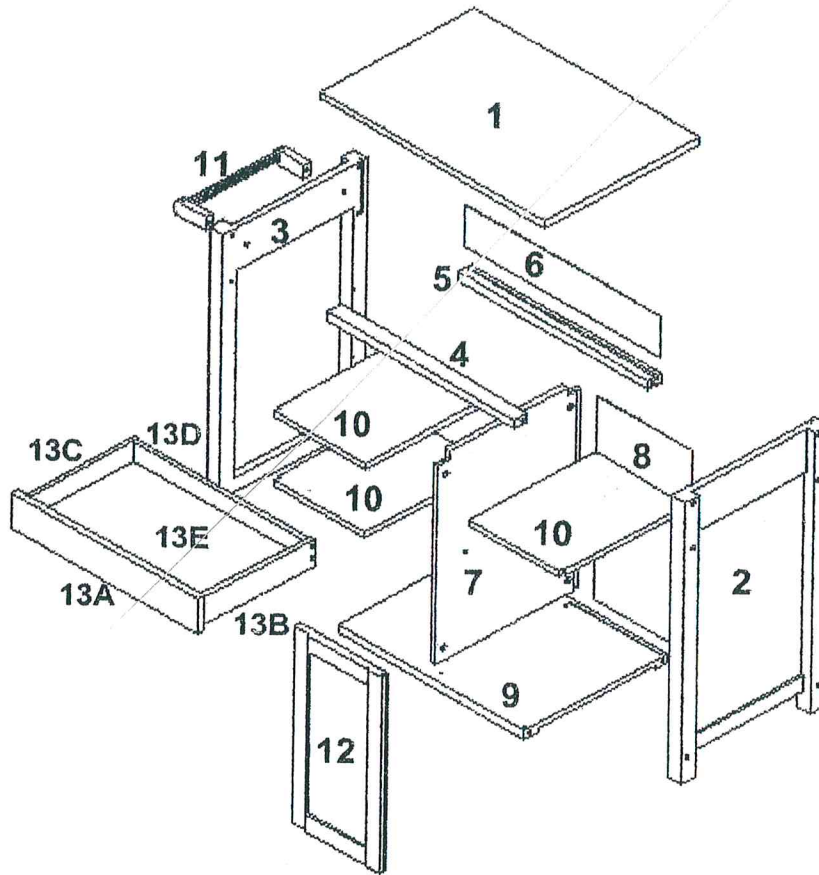

A x 12



B x 4



C x 2

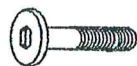

D x 2



E x 2



F x 4



G x 4



H x 12



I x 2

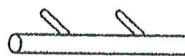

J x 4



K x 1



L x 2



M x 1



N x 2



O x 8



P x 12



Q x 2



R x 2



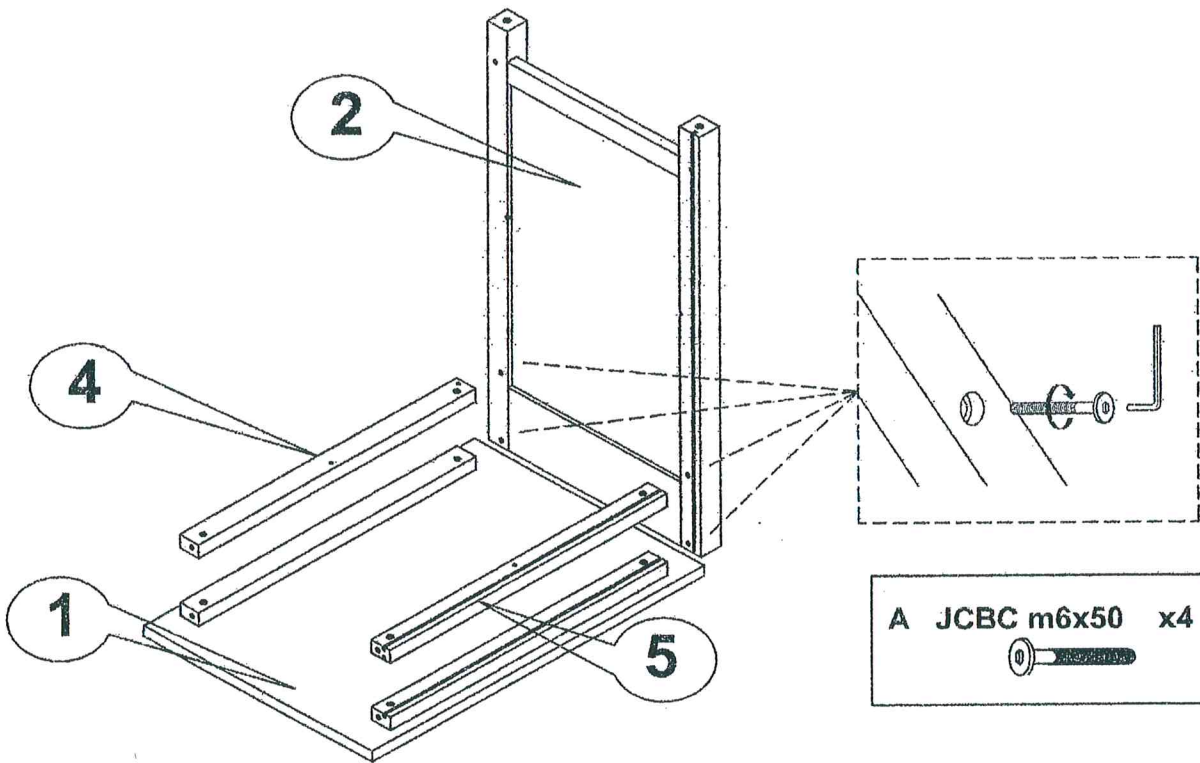

STEP 1

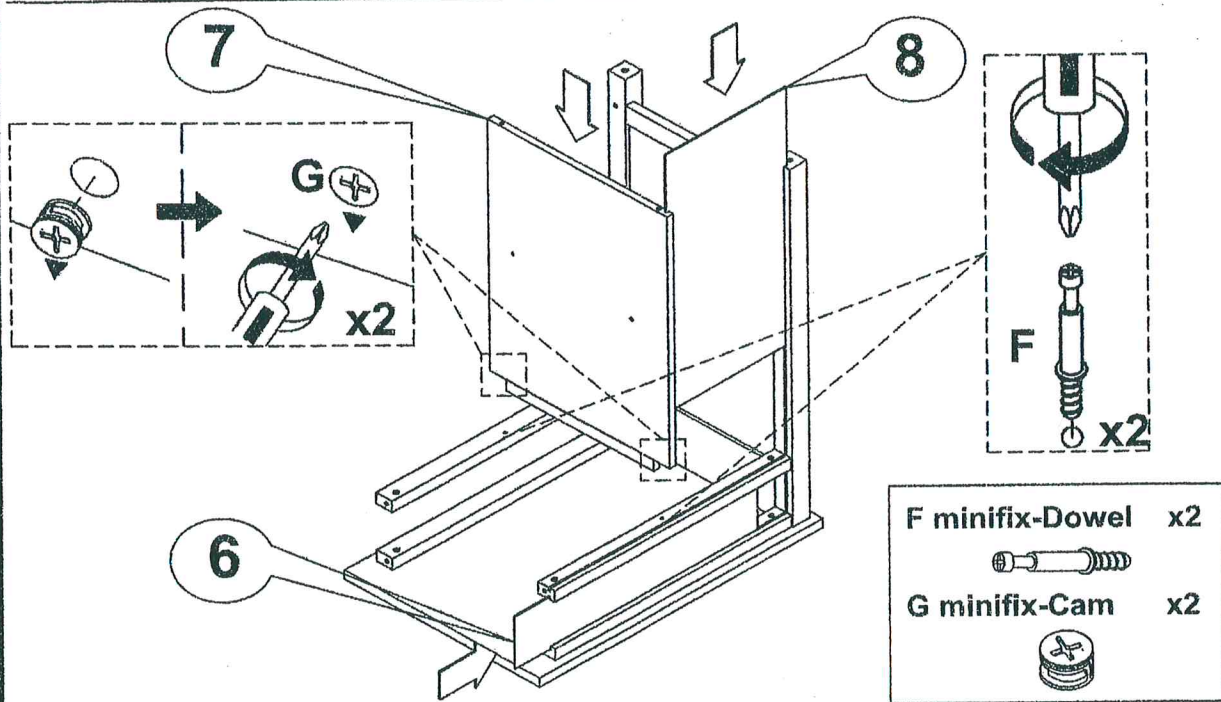

STEP 2

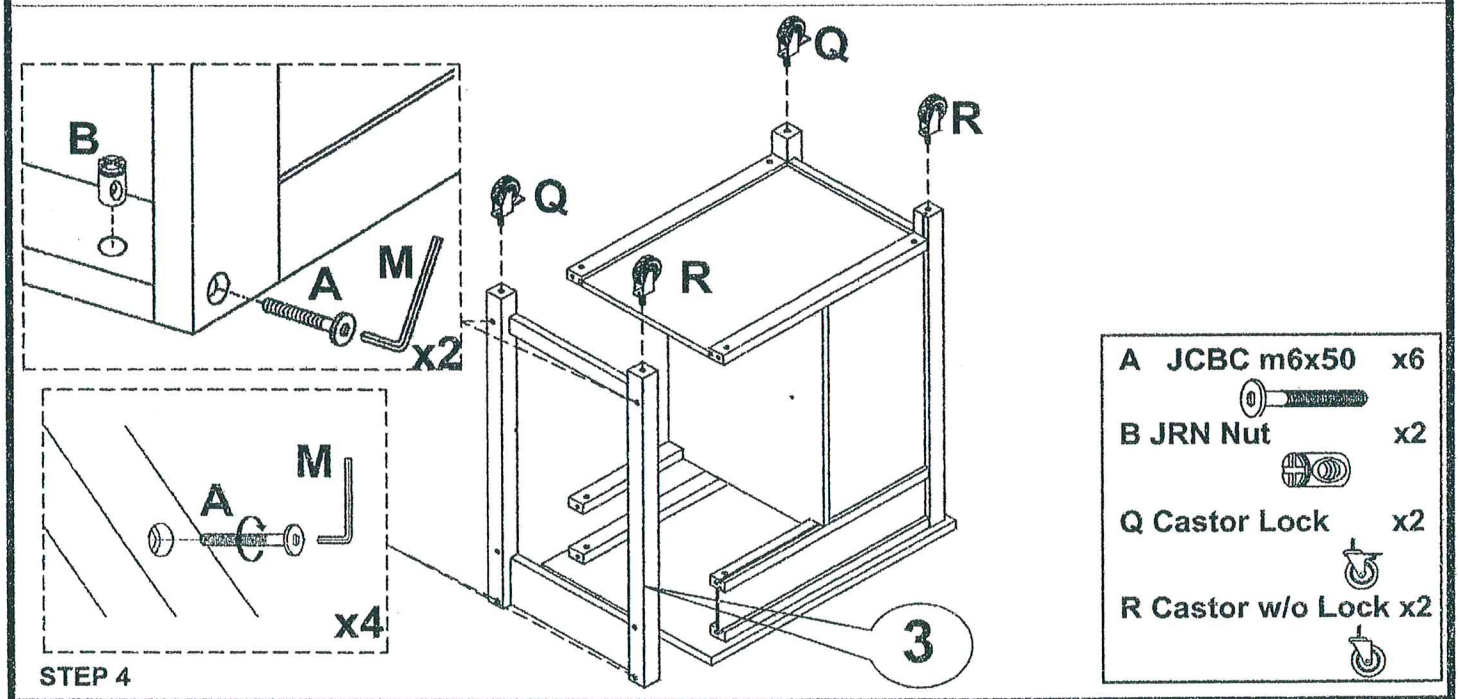
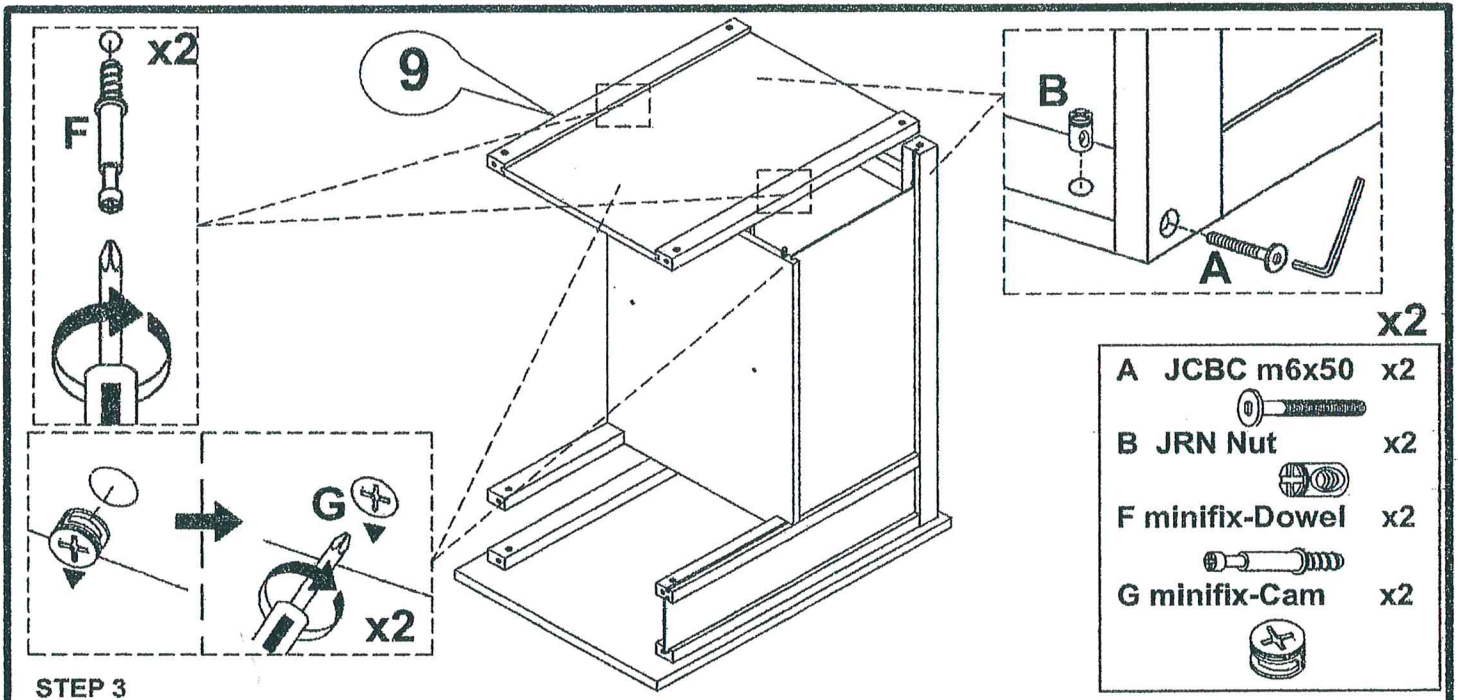

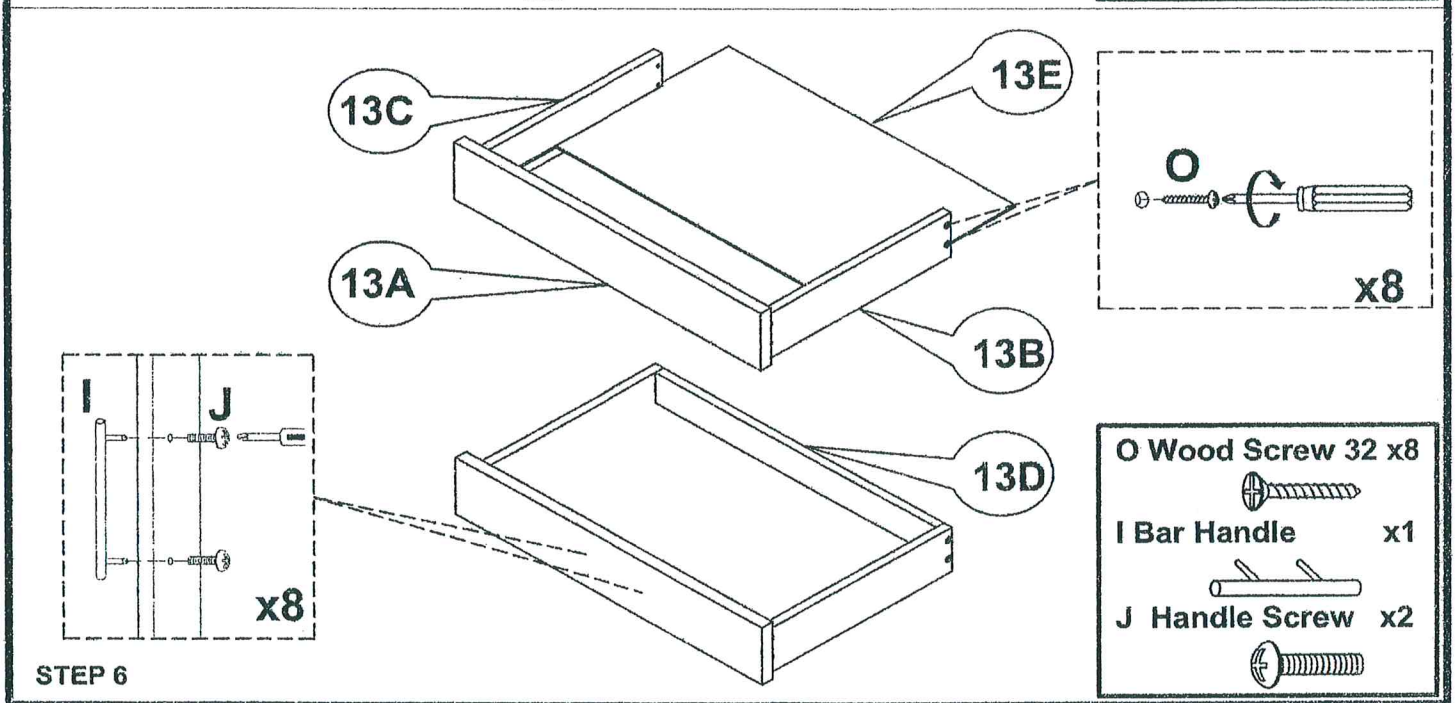
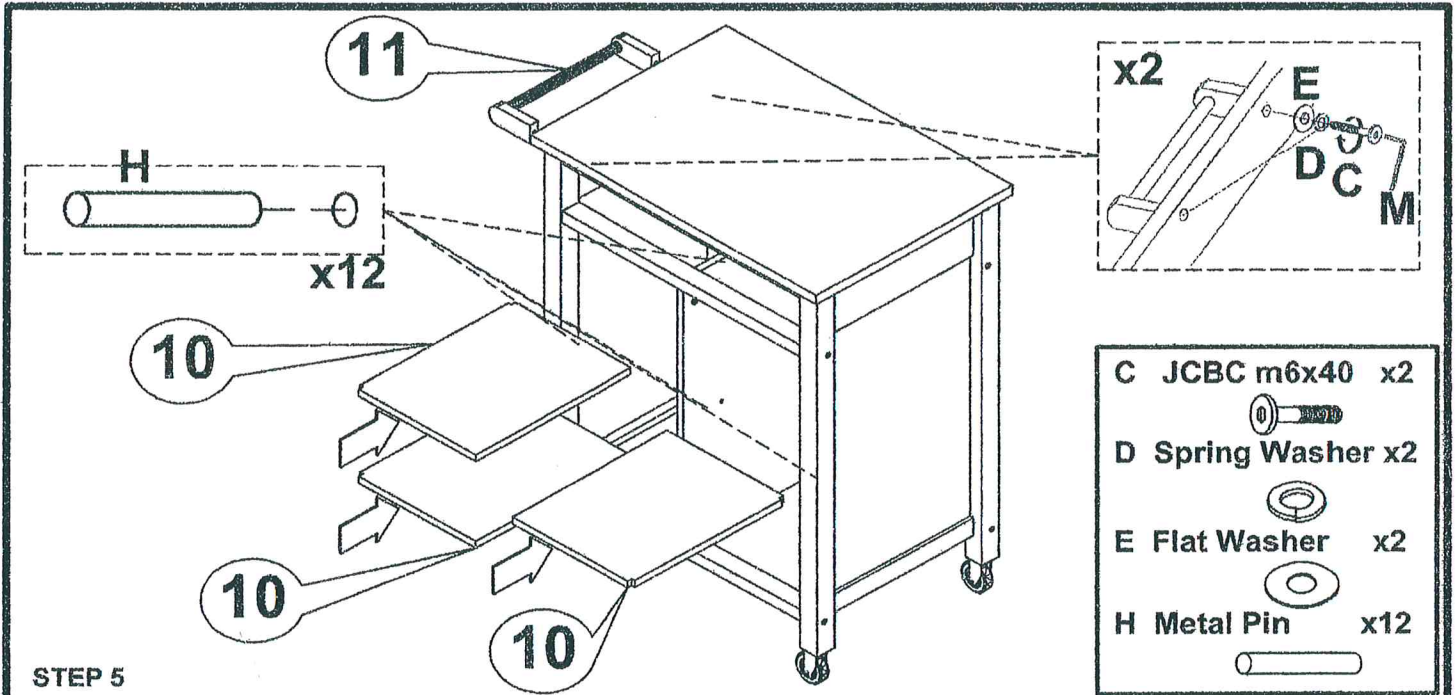

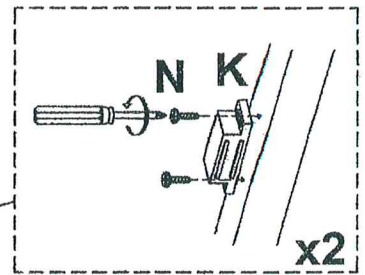
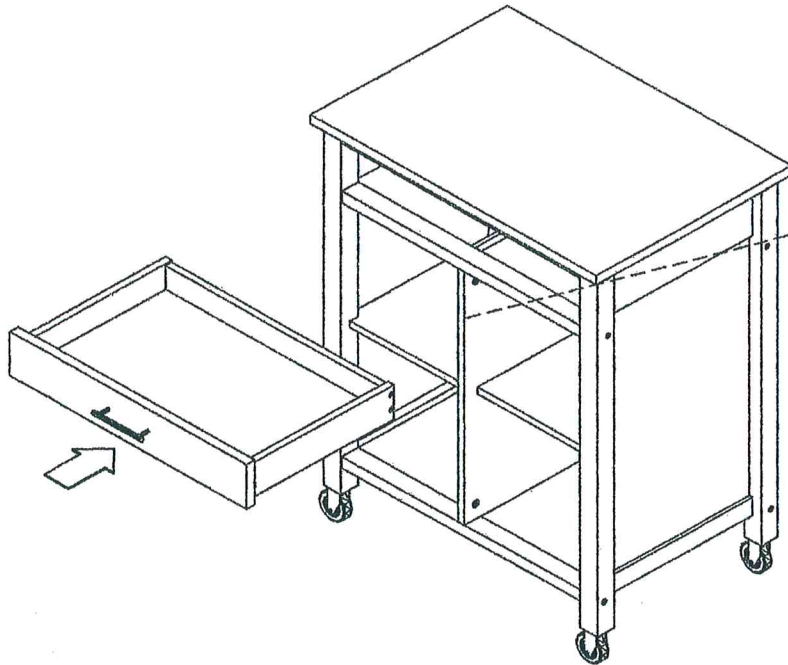

- K Magnetic Catch x1
- N Wood Screw 16 x2

STEP 7

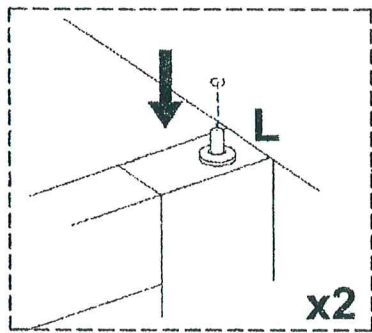

x2

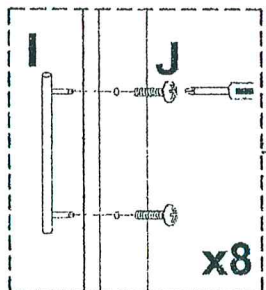

x8

12

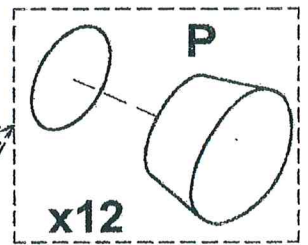
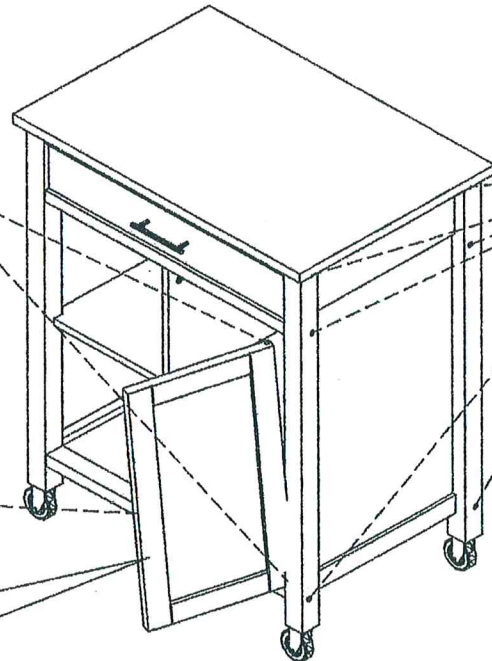

x12

- I Bar Handle x1
- J Handle Screw x2
- L Door Spring x2
- P Wood Button x12

STEP 8