



# **Dumpster Dolly**

## **OWNER'S MANUAL**



### **WARNING:**

Read carefully and understand all **ASSEMBLY AND OPERATION INSTRUCTIONS** before operating. Failure to follow the safety rules and other basic safety precautions may result in serious personal injury.

**Item# TTF-DD**

Thank you very much for choosing this product! For future reference, please complete the owner's record below:

Model: \_\_\_\_\_ Purchase Date: \_\_\_\_\_

Save the receipt, warranty and these instructions. It is important that you read the entire manual to become familiar with this product before you begin using it.

This product is designed for certain applications only. The manufacturer cannot be responsible for issues arising from modification. We strongly recommend this product not be modified and/or used for any application other than that for which it was designed. If you have any questions relative to a particular application, DO NOT use the product until you have first contacted us to determine if it can or should be performed on the product.

For technical questions please call **1-218-943-6296**.

## INTENDED USE

To make an easy way to transport trash and recycle bins to the road.

## TECHNICAL SPECIFICATIONS

Item	Description
Height Adjustment	13" to 21"
Construction	1.5" x 1.5" Steel Tubing

## GENERAL SAFETY RULES



**WARNING:** Read and understand all instructions. Failure to follow all instructions listed below may result in serious injury.



**CAUTION:** Do not allow persons to operate or assemble this Dumpster Dolly until they have read this manual and have developed a thorough understanding of how the Dumpster Dolly works.



**WARNING:** The warnings, cautions, and instructions discussed in this instruction manual cannot cover all possible conditions or situations that could occur. It must be understood by the operator that common sense and caution are factors which cannot be built into this product, but must be supplied by the operator.

## SAVE THESE INSTRUCTIONS

## WORK AREA

- **Keep work area clean**, free of clutter and well lit. Cluttered and dark work areas can cause accidents.
- **Keep children and bystanders** away while operating a Dumpster Dolly. Distractions can cause you to lose control, so visitors should remain at a safe distance from the work area.
- **Be alert of your surroundings.** Using a **Dumpster Dolly** in confined work areas may put you dangerously close to cutting tools and rotating parts.

## PERSONAL SAFETY

- **Stay alert**, watch what you are doing and use common sense when using a Dumpster Dolly. Do not use a Dumpster Dolly while you are tired or under the influence of drugs, alcohol or medication. A moment of inattention while operating a Dumpster Dolly may result in serious personal injury.
- **Dress properly.** Do not wear loose clothing, dangling objects, or jewelry. Keep your hair, clothing and gloves away from moving parts. Loose clothes, jewelry or long hair can be caught in moving parts.
- **Use safety apparel and equipment.** Use safety goggles or safety glasses with side shields which comply with current national standards, or when needed, a face shield. Use a dust mask if working in dusty work conditions. This applies to all persons in the work area. Also use non-skid safety shoes, hardhat, gloves, dust collection systems, and hearing protection when appropriate.

## Dumpster Dolly USE AND CARE

- **Do not modify the Dumpster Dolly in any way.** Unauthorized modification may impair the function and/or safety and could affect the life of the equipment. There are specific applications for which the Dumpster Dolly was designed.
- **Always check for damaged or worn out parts before using the Dumpster Dolly.** Broken parts will affect the Dumpster Dolly operation. Replace or repair damaged or worn parts immediately.
- **Do not exceed the Dumpster Dolly load capacity.**
- **Distribute the load evenly.** Uneven loads may cause the Dumpster Dolly to tip, resulting in personal injury to the operator or others.
- **Use the Dumpster Dolly on flat and level surfaces** capable of supporting the Dumpster Dolly and its maximum load. Pulling or pushing a load on a slanted or uneven surface can result in loss of control.
- **Store idle Dumpster Dolly.** When Dumpster Dolly is not in use, store it in a secure place out of the reach of children. Inspect it for good working condition prior to storage and before re-use.

## ASSEMBLY

1. Slide Fasten Bracket(#A) into Adjust Bracket(#B).
2. Tighten Locking Handwheel(#H)
3. Attach Adjust Plate(#C) to Fasten Bracket(#A) with Bolts(#D), Washers(#E&#F), and Nuts(#G).

## OPERATION

1. Slide over 2" Ball
2. Adjust to desired height using Handwheel (#H)

## MAINTENANCE

- Maintain your Dumpster Dolly.** It is recommended that the general condition of any Dumpster Dolly be examined before it is used. Keep your Dumpster Dolly in good repair by adopting a program of conscientious repair and maintenance. If any abnormal vibrations or noise occurs, have the problem corrected before further use. Have necessary repairs made by qualified service personnel.

## DIAGRAM & PARTS LIST

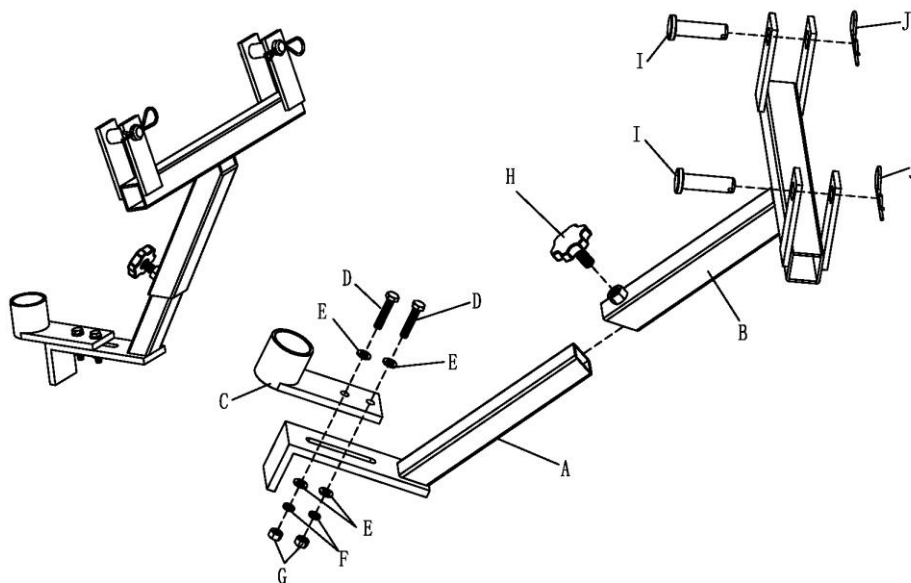

Part#	Description	Qty.	Part#	Description	Qty.
A	Fasten Bracket	1	F	Spring Washer 12	2
B	Adjust Bracket	1	G	Nut M12	2
C	Adjust Plate	1	H	Locking Handwheel	1
D	Bolt M8 x 50	2	I	Pin Ø10 x 60mm	2
E	Plain Washer 12	4	J	R-Pin Ø2.5 x 35mm	2

For replacement parts and technical questions, please call **1-218-943-6296**.

## WARRANTY

**One-year limited parts warranty**



PO BOX 203  
Miltona, MN 56354