



**HOBART**  
WELDING PRODUCTS

OM-281996B

2018-06

# Creator™ Series Auto-Darkening Welding Helmets

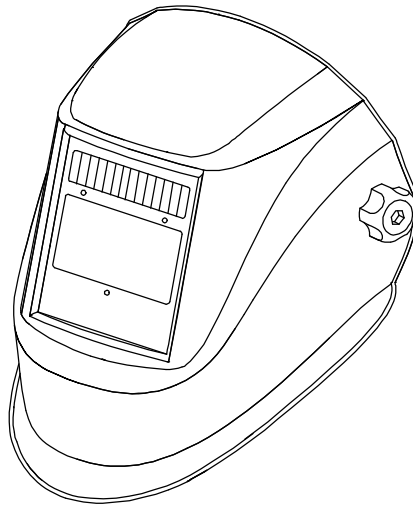

**OWNER'S MANUAL**



Find us on

Facebook



[www.HobartWelders.com](http://www.HobartWelders.com)

# TABLE OF CONTENTS

---

<b>SECTION 1 – WELDING HELMET SAFETY PRECAUTIONS –READ BEFORE USING</b>	<b>1</b>
1-1. Symbol Usage	1
1-2. Arc Welding Hazards	1
1-3. Proposition 65 Warnings	2
1-4. Lens Shade Selection Table	3
1-5. Principal Safety Standards	3
<b>SECTION 2 – SPECIFICATIONS</b>	<b>4</b>
<b>SECTION 3 – OPERATING INSTRUCTIONS</b>	<b>5</b>
3-1. Helmet Controls	5
3-2. Low Battery Indicator	5
3-3. Lens Delay Control	6
3-4. Variable Shade Control (No. 9–13)	6
3-5. Sensitivity Control	7
3-6. Weld/Grind Mode Switch	8
3-7. Power Modes	8
<b>SECTION 4 – ADJUSTING HEADGEAR</b>	<b>9</b>
<b>SECTION 5 – REPLACING THE LENS COVERS</b>	<b>10</b>
5-1. Replacing Outside Lens Cover	10
5-2. Replacing Inside Lens Cover	11
<b>SECTION 6 – REPLACING THE BATTERY</b>	<b>12</b>
<b>SECTION 7 – INSTALLING OPTIONAL MAGNIFYING LENS</b>	<b>13</b>
<b>SECTION 8 – MAINTENANCE</b>	<b>13</b>
<b>SECTION 9 – TROUBLESHOOTING</b>	<b>14</b>
<b>SECTION 10 – PARTS LIST</b>	<b>15</b>
<b>SECTION 11 – LIMITED WARRANTY</b>	<b>16</b>

# SECTION 1 – WELDING HELMET SAFETY PRECAUTIONS – READ BEFORE USING

helmet 2018-04

-  **Protect yourself and others from injury — read, follow, and save these important safety precautions and operating instructions.**

## 1-1. Symbol Usage



**DANGER!** – Indicates a hazardous situation which, if not avoided, will result in death or serious injury. The possible hazards are shown in the adjoining symbols or explained in the text.

 Indicates special instructions.



Indicates a hazardous situation which, if not avoided, could result in death or serious injury. The possible hazards are shown in the adjoining symbols or explained in the text.

This group of symbols means Warning! Watch Out! ELECTRIC SHOCK, MOVING PARTS, and HOT PARTS hazards. Consult symbols and related instructions below for necessary actions to avoid the hazards.

**NOTICE** – Indicates statements not related to personal injury.

## 1-2. Arc Welding Hazards

-  **Only qualified persons should install, operate, maintain, and repair this equipment. A qualified person is defined as one who, by possession of a recognized degree, certificate, or professional standing, or who by extensive knowledge, training and experience, has successfully demonstrated ability to solve or resolve problems relating to the subject matter, the work, or the project and has received safety training to recognize and avoid the hazards involved.**



### ARC RAYS can burn eyes and skin.

Arc rays from the welding process produce intense visible and invisible (ultraviolet and infrared) rays that can burn eyes and skin. Sparks fly off from the weld.

- Wear a welding helmet fitted with a proper shade of filter to protect your face and eyes when welding or watching (see ANSI Z49.1 and Z87.1 listed in Safety Standards). Refer to Lens Shade Selection table in Section 1-4.
- Wear approved safety glasses with side shields under your helmet.
- Use protective screens or barriers to protect others from flash, glare, and sparks; warn others not to watch the arc.
- Wear body protection made from durable, flame-resistant material (leather, heavy cotton, wool). Body protection includes oil-free clothing such as leather gloves, heavy shirt, cuffless trousers, high shoes, and a cap.
- Before welding, adjust the auto-darkening lens sensitivity setting to meet the application.
- Stop welding immediately if the auto-darkening lens does not darken when the arc is struck.

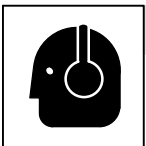

### NOISE can damage hearing.

Noise from some processes or equipment can damage hearing.

- Wear approved ear protection if noise level is high.



## **WELDING HELMETS do not provide unlimited eye, ear, and face protection.**

Arc rays from the welding process produce intense visible and invisible (ultraviolet and infrared) rays that can burn eyes and skin. Sparks fly off from the weld.

- Use helmet for welding/cutting applications only. Do not use helmet for laser welding/cutting.
- Use impact resistant safety spectacles or goggles and ear protection at all times when using this welding helmet.
- Do not use this helmet while working with or around explosives or corrosive liquids.
- Do not weld in the overhead position while using this helmet.
- Inspect the auto-lens frequently. Immediately replace any scratched, cracked, or pitted cover lenses or auto-lenses.
- Lens and retention components must be installed as instructed in this manual to ensure compliance with ANSI Z87.1 protection standards.

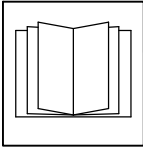

## **READ INSTRUCTIONS.**

- Read and follow all labels and the Owner's Manual carefully before installing, operating, or servicing unit. Read the safety information at the beginning of the manual and in each section.

- Use only genuine replacement parts from the manufacturer.
- Perform installation, maintenance, and service according to the Owner's Manuals, industry standards, and national, state, and local codes.



## **FUMES AND GASES can be hazardous.**

Welding produces fumes and gases. Breathing these fumes and gases can be hazardous to your health.

- Keep your head out of the fumes. Do not breathe the fumes.
- Ventilate the work area and/or use local forced ventilation at the arc to remove welding fumes and gases. The recommended way to determine adequate ventilation is to sample for the composition and quantity of fumes and gases to which personnel are exposed.
- If ventilation is poor, wear an approved air-supplied respirator.
- Read and understand the Safety Data Sheets (SDSs) and the manufacturer's instructions for adhesives, coatings, cleaners, consumables, coolants, degreasers, fluxes, and metals.
- Work in a confined space only if it is well ventilated, or while wearing an air-supplied respirator. Always have a trained watchperson nearby. Welding fumes and gases can displace air and lower the oxygen level causing injury or death. Be sure the breathing air is safe.
- Do not weld in locations near degreasing, cleaning, or spraying operations. The heat and rays of the arc can react with vapors to form highly toxic and irritating gases.
- Do not weld on coated metals, such as galvanized, lead, or cadmium plated steel, unless the coating is removed from the weld area, the area is well ventilated, and while wearing an air-supplied respirator. The coatings and any metals containing these elements can give off toxic fumes if welded.

## **1-3. Proposition 65 Warnings**



**WARNING: Cancer and Reproductive Harm – [www.P65Warnings.ca.gov](http://www.P65Warnings.ca.gov)**

## 1-4. Lens Shade Selection Table

Process	Electrode Size in. (mm)	Arc Current in Amperes	Minimum Protective Shade No.	Suggested Shade No. (Comfort)*
Shielded Metal Arc Welding (SMAW)	Less than 3/32 (2.4) 3/32–5/32 (2.4–4.0) 5/32–1/4 (4.0–6.4) More than 1/4 (6.4)	Less than 60	7	—
		60–160	8	10
		160–250	10	12
		250–550	11	14
Gas Metal Arc Welding (GMAW)  Flux Cored Arc Welding (FCAW)		Less than 60	7	—
		60–160	10	11
		160–250	10	12
		250–500	10	14
Gas Tungsten Arc Welding (TIG)		Less than 50	8	10
		50–150	8	12
		150–500	10	14
Air Carbon Arc Cutting (CAC-A)	Light Heavy	Less than 500	10	12
		500–1000	11	14
Plasma Arc Cutting (PAC)		Less than 20	4	4
		20–40	5	5
		40–60	6	6
		60–80	8	8
		80–300	8	9
		300–400	9	12
		400–800	10	14
Plasma Arc Welding (PAW)		Less than 20	6	6–8
		20–100	8	10
		100–400	10	12
		400–800	11	12
			11	14

Reference: ANSI Z49.1:2012

- \* Start with a shade that is too dark to see the weld zone. Then, go to a lighter shade which gives a sufficient view of the weld zone without going below the minimum.

## 1-5. Principal Safety Standards

*Safety in Welding, Cutting, and Allied Processes*, ANSI Standard Z49.1, is available as a free download from the American Welding Society at <http://www.aws.org> or purchased from Global Engineering Documents (phone: 1-877-413-5184, website: [www.global.ihs.com](http://www.global.ihs.com)).

*Safe Practice For Occupational And Educational Eye And Face Protection*, ANSI Standard Z87.1, from American National Standards Institute, 25 West 43rd Street, New York, NY 10036 (phone: 212-642-4900, website: [www.ansi.org](http://www.ansi.org)).

*Industrial Head Protection*, ANSI/ISEA Standard Z89.1, from American National Standards Institute, 25 West 43rd Street, New York, NY 10036 (phone: 212-642-4900, website: [www.ansi.org](http://www.ansi.org)).



## SECTION 3 – OPERATING INSTRUCTIONS

### 3-1. Helmet Controls

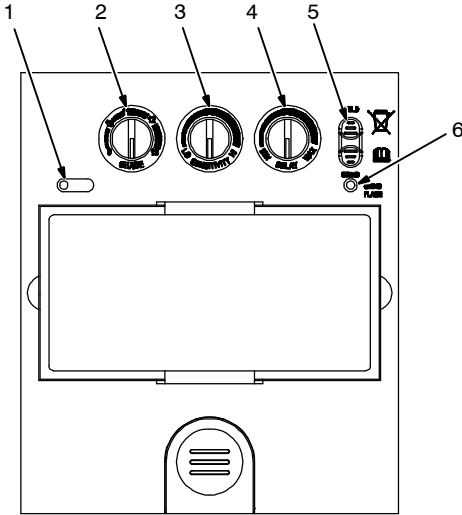
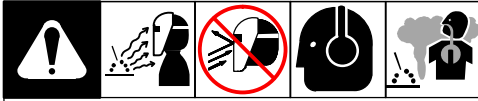

Remove protective films from lens before welding.

- 1 Low Battery Indicator (See Section 3-2)
- 2 Variable Shade Control (See Section 3-4)
- 3 Sensitivity Control (See Section 3-5)
- 4 Lens Delay Control (See Section 3-3)
- 5 Weld/Grind Mode Switch (See Section 3-6)
- 6 Grind Mode Indicator (See Section 3-6)

### 3-2. Low Battery Indicator

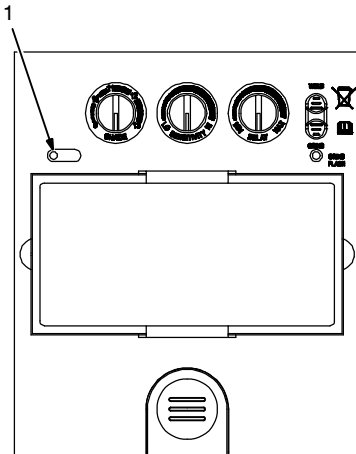
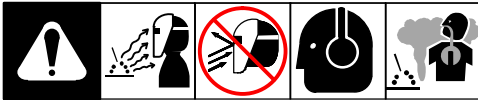

#### 1 Low Battery Indicator

The low battery indicator lights when 2–3 days of battery life remain. If battery power is low, install new CR2450 lithium batteries (see Section 6).

The auto-darkening lens consumes less than 1 microamp of battery power when in the sleep mode. See Section 3-7 for more information on battery usage in the different power modes.

### 3-3. Lens Delay Control

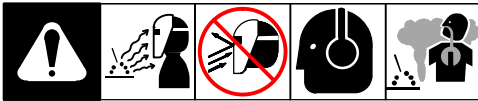

☞ Place Weld/Grind mode switch in Weld position (Section 3-6).

#### 1 Lens Delay Control

The lens delay control is used to adjust the time for the lens to switch to the clear state after welding.

The delay is particularly useful in eliminating bright after-rays present in higher amperage applications where the molten puddle remains bright momentarily after welding. Lens delay adjusts from min (0.1 second) to max (0.9 second).

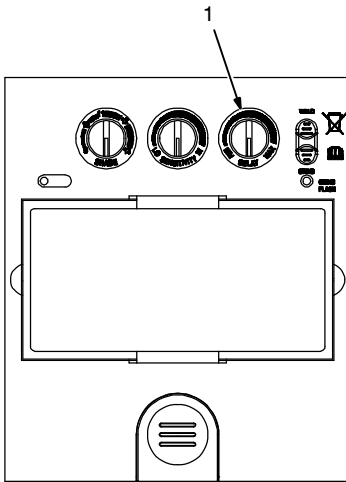

### 3-4. Variable Shade Control (No. 9–13)

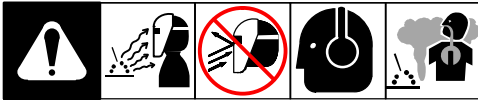

☞ Place Weld/Grind mode switch in Weld position (Section 3-6).

#### 1 Variable Shade Control (No. 9–13)

Use the control to adjust the lens shade in the darkened state. Use the table in Section 1-4 to select proper shade control setting based on your welding process.

Start at the highest setting and adjust lighter to suit the welding application and your personal preference.

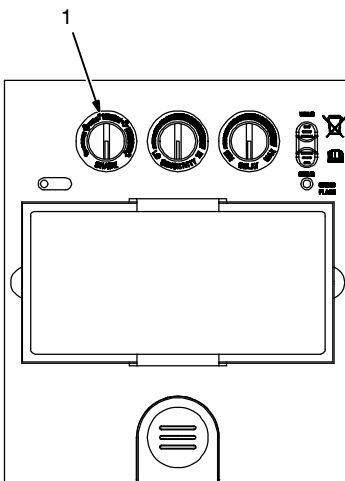



### 3-5. Sensitivity Control

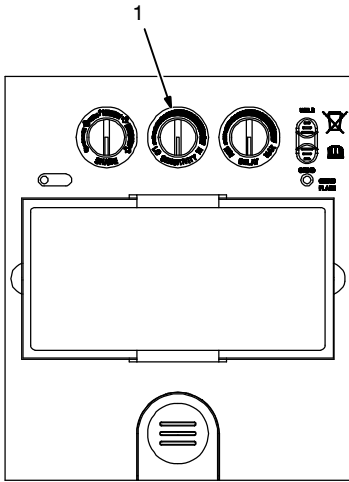
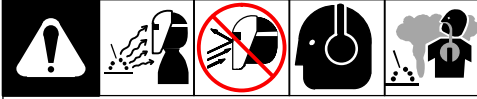

☞ Place Weld/Grind mode switch in Weld position (Section 3-6).

#### 1 Sensitivity Control

Use control to make the lens more responsive to different light levels in various welding processes. **Use a Mid-Range or 50-70% sensitivity setting for most applications.**

It may be necessary to adjust helmet sensitivity to accommodate different lighting conditions or if lens is flashing on and off. Adjust helmet sensitivity as follows:

☞ Adjust helmet sensitivity in lighting conditions helmet will be used in.

- Turn sensitivity control to lowest setting.
- Face the helmet in the direction of use, exposing it to the surrounding light conditions.
- Gradually turn sensitivity setting clockwise until the lens darkens, then turn sensitivity control counterclockwise until slightly past setting where lens clears. Helmet is ready for use. Slight readjustment may be necessary for certain applications or if lens is blinking on and off.

#### Recommended Sensitivity Settings

Stick Electrode	Mid-Range
Short Circuiting (MIG)	Low/Mid-Range
Pulsed And Spray (MIG)	Mid-Range
Gas Tungsten Arc (TIG)	Mid/High-Range
Plasma Arc Cutting/Welding	Low/Mid-Range
Grinding	Place Weld/Grind Mode Switch In Grind Position

### 3-6. Weld/Grind Mode Switch

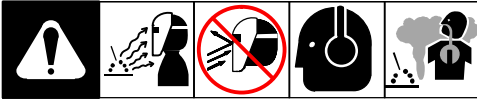

- 1 Weld/Grind Mode Switch
- 2 Grind Mode Indicator

Place switch in Grind mode for grinding applications. To resume welding, place switch in Weld mode. The Grind Mode indicator will blink when helmet is in Grind mode.

 Do not weld in the Grind mode; the lens will not darken.

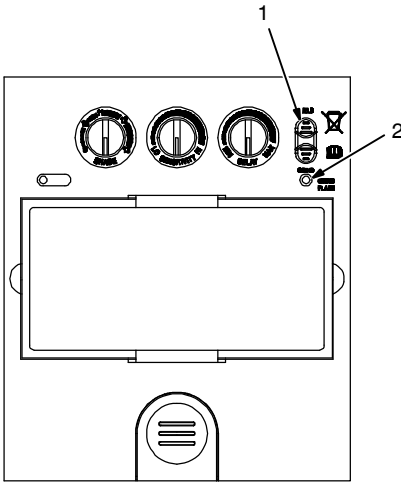

### 3-7. Power Modes

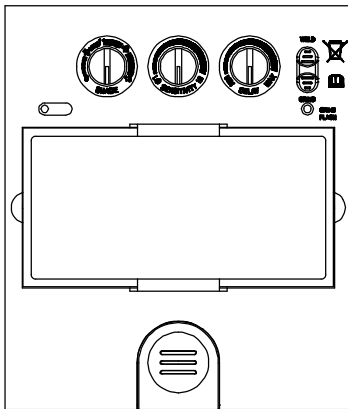

The auto-darkening lens has three power modes: sleep (off), standby, and on. The lens goes to sleep automatically when ambient light is low (less than 3 lux). The lens consumes less than 1 microamp of battery power when in the sleep mode.

When ambient light exceeds 10 lux, the lens automatically changes to the standby mode and is ready for welding. The lens relies on the solar cell for power when in standby mode.

When welding begins, the lens automatically turns on (darkens). In most cases, the solar cell provides enough power to operate the lens during welding. However, the lens may use both solar and battery power when shade control is at a high setting.

The lens returns to standby mode immediately after welding stops, and then enters sleep mode if ambient lighting is low (less than 3 lux).

## SECTION 4 – ADJUSTING HEADGEAR

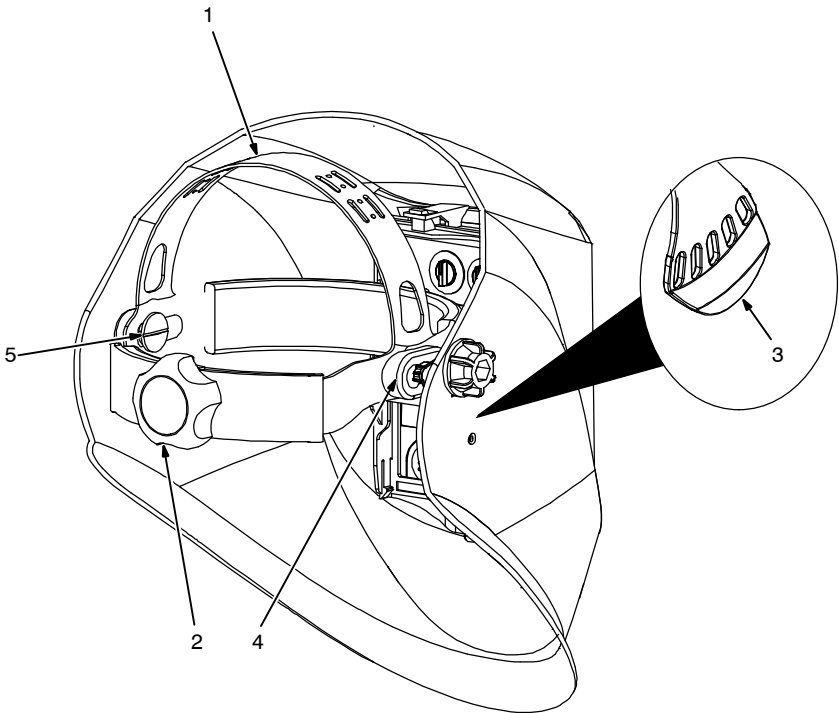
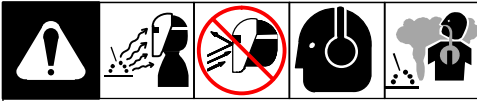

☞ *There are four headgear adjustments: headgear top, tightness, angle adjustment, and distance adjustment.*

### 1 Headgear Top Adjustment

Adjusts headgear for proper depth on the head to ensure correct balance and stability.

### 2 Headgear Tightness Adjustment

To adjust, turn the adjusting knob located on the back of the headgear left or right to desired tightness.

### 3 Angle Adjustment

Slots on the right side of the headband provide adjustment for the forward tilt of the helmet. To adjust, lift and reposition the control arm to the desired position.

### 4 Distance Adjustment

### 5 Headgear Screw

Adjusts the distance between the face and the lens. To adjust, loosen headgear screws and slide headgear forward or backward to one of the three slots on the slider. Tighten screws. (Both sides must be equally positioned for proper vision.)

## SECTION 5 – REPLACING THE LENS COVERS

### 5-1. Replacing Outside Lens Cover



**⚠** Never use the auto-darkening lens without the inside and outside lens covers properly installed. Welding spatter will damage the auto-darkening lens and void the warranty.

- 1 Locking Tab
- 2 Lens Assembly
- 3 Outside Lens Cover

Remove lens assembly by sliding the locking tab to the left. Remove cartridge and lens cover.

Install new lens cover. Install lens assembly and slide locking tab to the right.

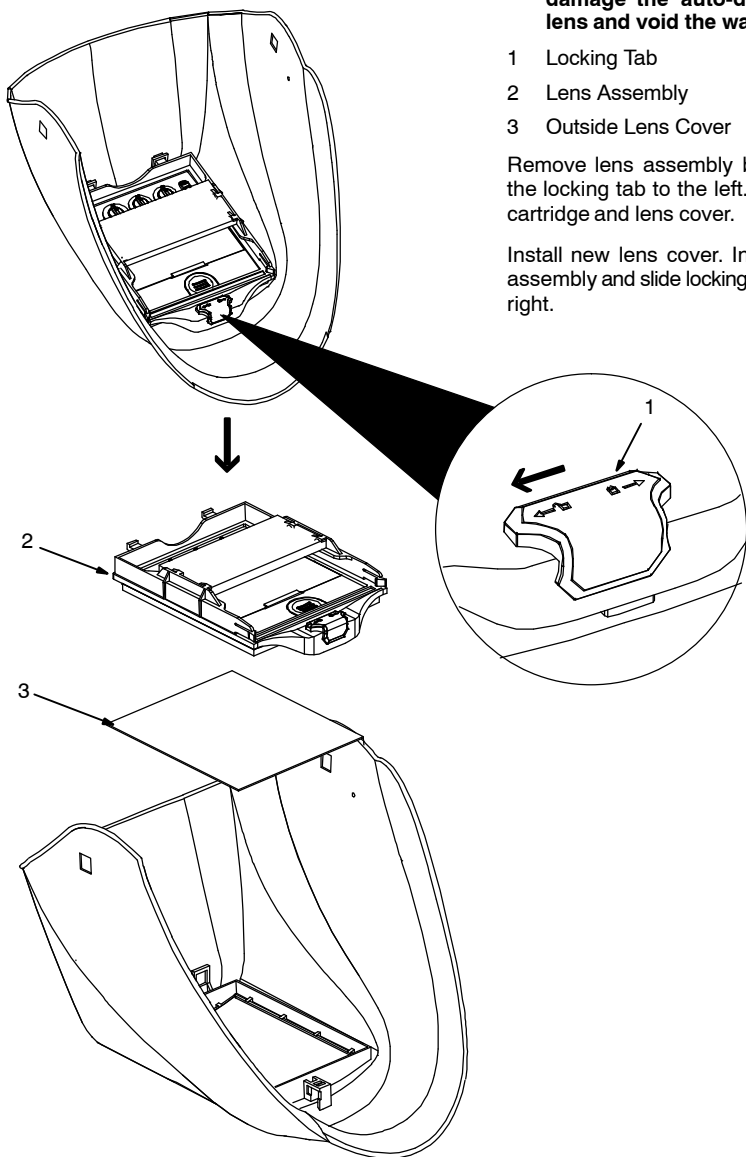

## 5-2. Replacing Inside Lens Cover

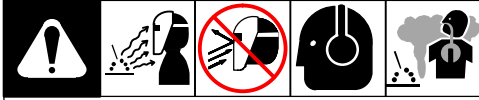

**⚠** Never use the auto-darkening lens without the inside and outside lens covers properly installed. Welding spatter will damage the auto-darkening lens and void the warranty.

- 1 Lens Assembly
- 2 inside Lens Cover

Remove the lens cover holder (see Section 5-1). Remove lens assembly.

Remove the inside lens cover by prying the cover up at either thumbnail opening at each side of the cover. Slide cover it out of either side of frame. Replace lens cover and reinstall the assembly in the helmet by reversing the above procedure.

*☞ Be sure the cover lens is seated properly (flat) to prevent fogging.*

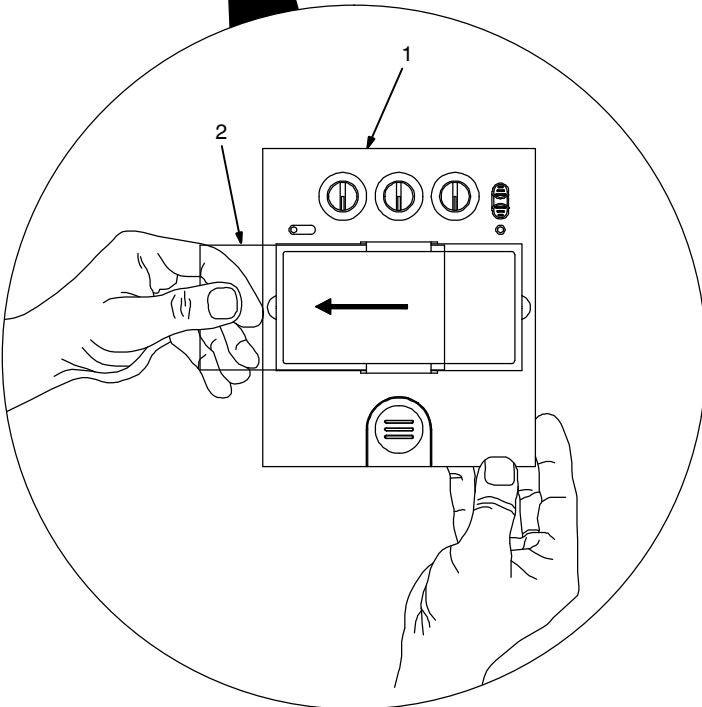
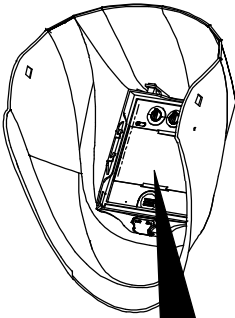

## SECTION 6 – REPLACING THE BATTERY



The helmet is powered by solar cells and a CR2450 lithium battery.

### 1 Low Battery Indicator

The low battery indicator lights when 2–3 days of battery life remain.

If battery power is low, install new CR2450 lithium battery.

### 2 Battery Cover

Slide the battery cover out and remove the old battery.

Install new CR2450 lithium battery. Reinstall cover.

 *Be sure Positive (+) side of the battery faces up (toward inside of helmet).*

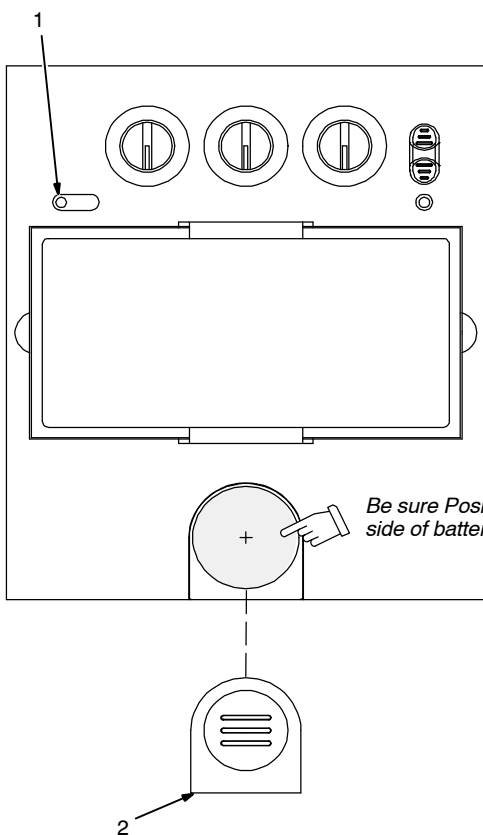

## SECTION 7 – INSTALLING OPTIONAL MAGNIFYING LENS

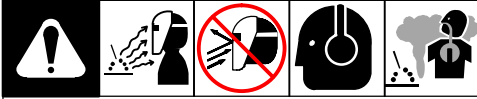

### 1 Optional Magnifying Lens

Slide magnifying lens into the helmet retaining brackets as shown. Align the magnifying lens with the auto-darkening lens assembly.

 To prevent lens fogging, install flat side of magnifying lens toward auto-darkening lens.

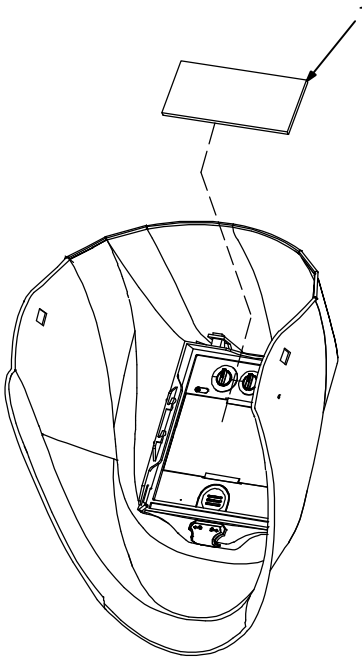

## SECTION 8 – MAINTENANCE

**NOTICE** – Never use solvents or abrasive cleaning detergents.

**NOTICE** – Do not immerse the lens assembly in water.

The helmet requires little maintenance. However, for best performance clean helmet after each use. Using a soft cloth dampened with a mild soap and water solution, wipe the cover lenses clean. Allow to air dry. Occasionally, the filter lens and sensors should be cleaned by gently wiping with a soft, dry cloth.

## SECTION 9 – TROUBLESHOOTING



Trouble	Remedy
Not switching – auto-lens stays light and will not darken when welding.	<p>Stop welding immediately. If power is on, review the sensitivity recommendations and adjust sensitivity. Make sure helmet is not in Grind mode. Clean lens cover and sensors of any obstructions. Make sure the sensors are facing the arc; angles of 45° or more may not allow the arc light to reach the sensors.</p> <p>Check battery and verify it is in good condition and installed properly. Also, check battery surface and contacts, and clean if necessary. Check battery for proper contact and gently adjust contact points if necessary. This is particularly important if the helmet has been dropped.</p>
Not Switching – auto-lens stays dark after the weld arc is extinguished, or the auto-lens stays dark when no arc is present.	<p>Fine-tune the sensitivity setting by making small adjustments to the control by turning it toward the LO setting. In extreme light conditions, it may be necessary to reduce the surrounding light levels.</p>
Sections of the auto-lens are not going dark, distinct lines separate the light and dark areas.	<p>Stop welding immediately: The auto-lens may be cracked which can be caused by the impact of dropping the helmet. Weld spatter on the auto lens may also cause cracking. (The lens may need to be replaced; most cracked lenses are not covered by warranty).</p>
Switching or Flickering – the auto-lens darkens then lightens while the welding arc is present.	<p>Review the sensitivity setting recommendations and increase the sensitivity if possible. Be sure the arc sensors are not being blocked from direct access to the arc light. Check the lens cover for dirt and spatter that may be blocking the arc sensors. Increasing Lens Delay slightly may also reduce switching.</p>
Inconsistent or lighter auto-lens shading in the dark-state, noticeable on the outside edges and corners.	<p>Referred to as an angle of view effect, auto-darkening lenses have an optimum viewing angle. The optimum viewing angle is perpendicular or 90° to the surface of the auto-lens. When that angle of view varies in the dark-state, welders may notice slightly lighter areas at the outside edges and the corners of the lens. This is normal and does not represent any health or safety hazard. This effect may also be more noticeable in applications where magnifying lenses are used.</p>



# SECTION 10 – PARTS LIST

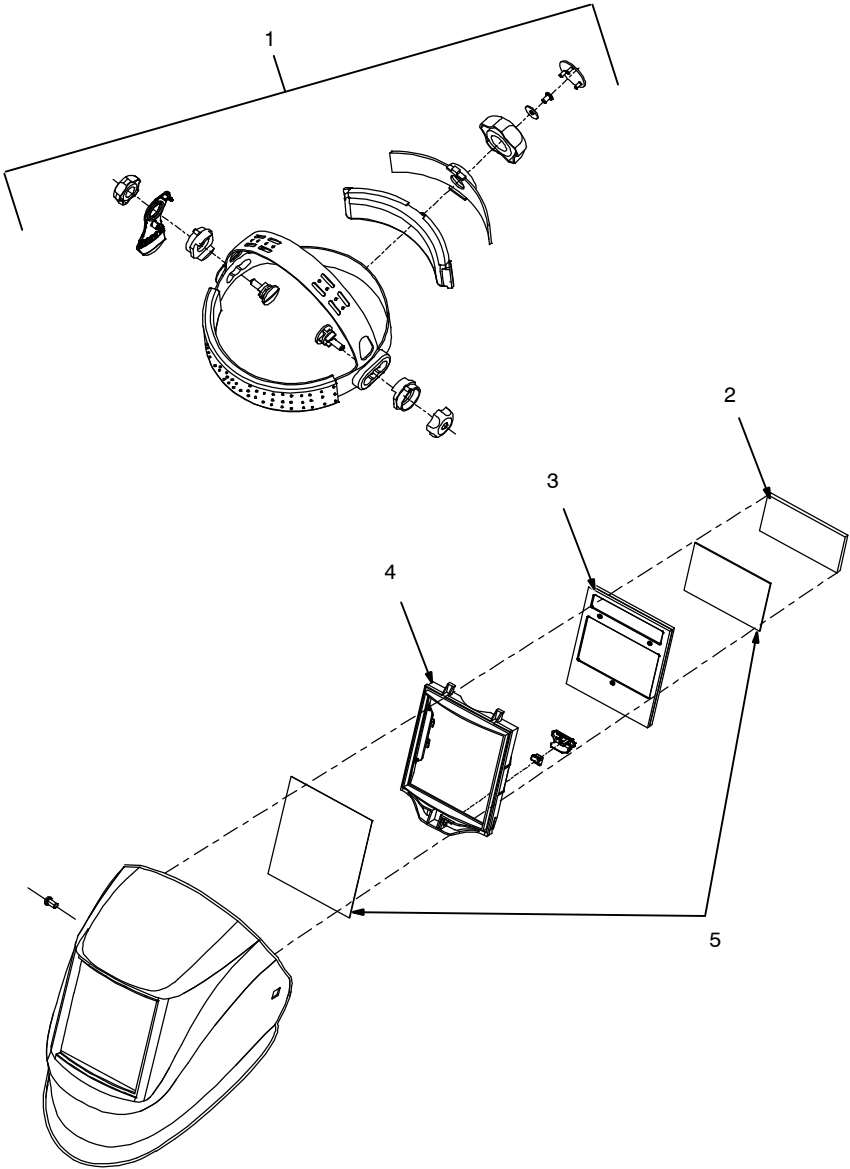

**Figure 10-1. Creator Series Auto-Darkening Welding Helmet**

Item No.	Part No.	Description	Quantity
----------	----------	-------------	----------

**Figure 10-1. Creator Series Auto-Darkening Welding Helmet**

1	770843	Headgear	1
2	◆ 770274	Dioptr Lens 150X	1
	◆ 770275	Dioptr Lens 175X	1
	◆ 770276	Dioptr Lens 200X	1
	◆ 770277	Dioptr Lens 250X	1
3	770845	Auto-Darkening Lens	1
	770284	Battery, CR2450	1
4	770883	Frame, Lens Replacement	1
5	770856	Kit, Clear Protective Lens	1

◆ Optional

**SECTION 11 – LIMITED WARRANTY**

**LIMITED WARRANTY** – Subject to the terms and conditions below, Miller Electric Mfg. LLC, dba Hobart Welding Products, Appleton, WI, warrants to its original retail purchaser that the new Hobart equipment sold after the effective date of this limited warranty is free of defects in material and workmanship at the time it is purchased at the retailer. THIS WARRANTY IS EXPRESSLY IN LIEU OF ALL OTHER WARRANTIES, EXPRESS OR IMPLIED, INCLUDING THE WARRANTIES OF MERCHANTABILITY AND FITNESS.

Hobart auto-darkening lens helmets are warranted for two (2) years from the date of purchase. **Proof of purchase is required for warranty transactions so it is imperative that a copy of the original invoice or sales receipt be retained.**

**For warranty transactions, contact your original Hobart retailer or call 1-800-332-3281**

Hob Helm 2018-01

Effective January 1, 2018





# **HOBART**<sup>®</sup>

## **WELDING PRODUCTS**

Miller Electric Mfg. LLC  
An Illinois Tool Works Company  
1635 West Spencer Street  
Appleton, WI 54914 USA

Phone: 800-332-3281

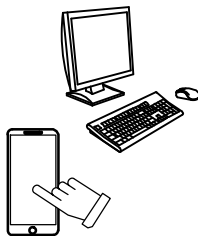

Visit our website at  
**[www.HobartWelders.com](http://www.HobartWelders.com)**