



DISPENSERS



FUEL KITS



PUMPS



METERS



NOZZLE



FILTRATION

# EX50



## FEATURES

- **UL-LISTED**
- **STURDY STRUCTURE**
- **FLANGED COMPONENTS**
- **ANTI-NOISE FILTER**
- **THERMAL PROTECTION**
- **BUILT-IN BYPASS VALVE**
- **SUCTION PIPE WITH INTEGRATED FILTER**

The PIUSI EX50 PRO/BASIC KITS are complete pump transfer kits expressly engineered for UL-Certification. This system is composed of a high-efficiency pump, automatic nozzle and a telescopic suction hose. Thanks to the flanged components, this transfer set allows users to replace any component without using sealants thus creating maximum versatility and adaptability to any kind of condition. Water captor filter available on request.

## PERFORMANCE

UP TO

**15 GPM**

AT-THE-NOZZLE

FLOW RATE

**43"**

LENGTH

SUCTION PIPE

**30 MIN**

ON AND OFF

DUTY CYCLE

**± 1%**

ACCURACY



EX50 PRO KIT - AUTO NOZZLE + K33 METER



EX50 BASIC KIT - AUTO NOZZLE



EX50 17 GPM BASIC KIT - MANUAL NOZZLE

## PACKAGING

PART #	WEIGHT		PACKAGING		
	KG	LBS	MM	INCH	PCS/BOX
<b>PRO KIT</b>					
FO037550C	7.9	17.4	356X191X267	24X16X11	1
FO037650C	7.9	17.4	356X191X267	24X16X11	1
<b>BASIC KIT</b>					
FO0372540	7.3	16.1	356X191X267	24X16X11	1
FO037251B	7.3	16.1	356X191X267	24X16X11	1
FO037451B	7.3	16.1	356X191X267	24X16X11	1
<b>PUMP ONLY</b>					
FO037250B	6.9	15.2	345X175X225	13.5X7X9	1
FO037450B	6.9	15.2	345X175X225	13.5X7X9	1



FLUID  
MONITORING

- A  
AIR
- A  
ANTIFREEZE
- D  
DEF
- B  
BIODIESEL
- D  
DIESEL
- F  
FOOD
- G  
GASOLINE
- G  
GREASE
- K  
KEROSENE
- O  
OIL
- W  
WATER
- W  
WINDSCREEN

## CHART

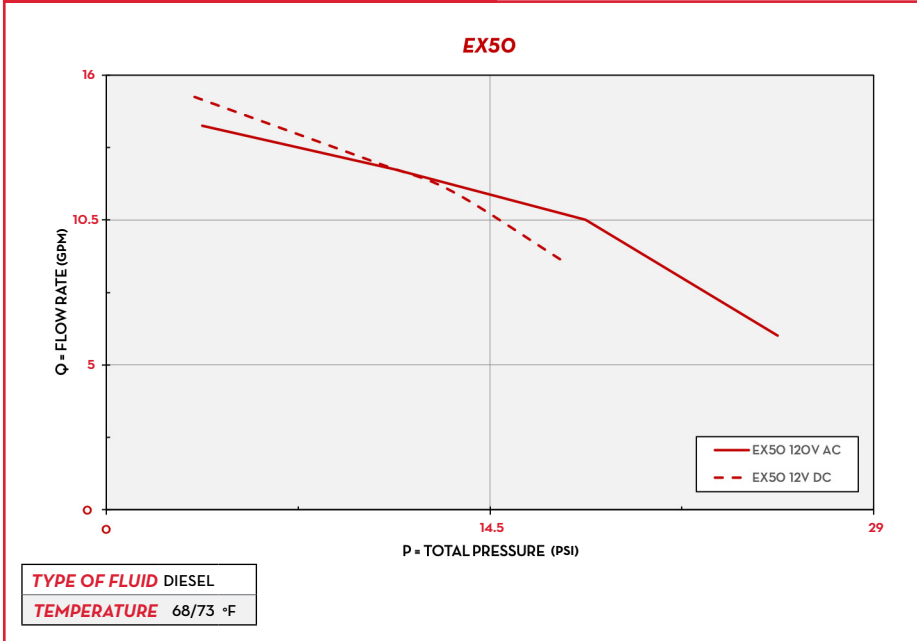

## IN THE BOX

- EX50 PUMP (120V OR 12V)
- TELESCOPIC SUCTION PIPE
- ANTI-KINK DELIVERY HOSE
- AUTOMATIC NOZZLE (MANUAL FOR EX50 17 GPM BASIC KIT)
- 2" CONNECTOR
- K33 MECHANICAL METER (PRO KIT ONLY)
- INSTRUCTION MANUAL

## DETAILS



## DIMENSIONS

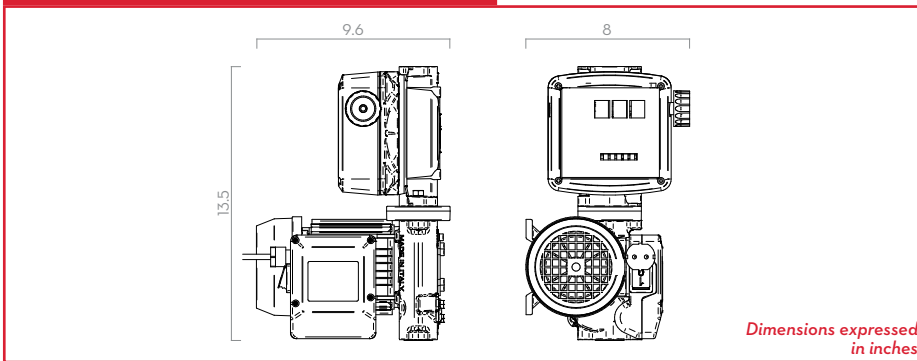

## COMPONENTS

- **METER:**  
K33 ATEX PG. 60
- **NOZZLE:**  
A60-UL PG. 86
- **FILTER:**  
WATER CAPTOR PG. 94

## TECHNICAL DATA

PART #	DESCRIPTION	FLUIDS TYPE	FLOW RATE		VOLTAGE			METER TYPE	NOZZLE TYPE	FILTER ON REQ.	INLET NPT	HOSE	
			L/MIN	GPM	AC V/HZ DC VOLT	POWER WATT	AMP. MAX.					LENGTH FT	Ø NPT
<b>PRO KIT</b>													
FO037550C	EX50 12V 15GPM FUEL PUMP PRO (AUTO/MTR)	D G K	50	15	12	250	17	K33	AUTO	YES	1"	13	3/4"
FO037650C	EX50 120V 15GPM FUEL PUMP PRO (AUTO/MTR)	D G K	50	15	120/60	250	1.7	K33	AUTO	YES	1"	13	3/4"
<b>BASIC KIT</b>													
FO0372540	EX50 12V 17GPM FUEL PUMP BASIC (MANUAL)	D G K	65	17	12	250	17	-	MAN.	YES	1"	13	3/4"
FO037251B	EX50 12V 15GPM FUEL PUMP BASIC (AUTO)	D G K	50	15	12	250	17	-	AUTO	YES	1"	13	3/4"
FO037451B	EX50 120V 15GPM FUEL PUMP BASIC (AUTO)	D G K	50	15	120/60	250	1.7	-	AUTO	YES	1"	13	3/4"
<b>PUMP ONLY</b>													
FO037250B	EX50 12V 15GPM UL FUEL (PUMP ONLY)	D G K	50	13	12	250	21	-	-	-	1"	-	-
FO037450B	EX50 120V 15GPM UL FUEL (PUMP ONLY)	D G K	50	13	120/60	250	1.7	-	-	-	1"	-	-

(\*) UPON REQUEST IT IS AVAILABLE WITH DIFFERENT VOLTAGES AND 60 HZ FREQUENCY.  
COMPATIBLE FLUIDS: DIESEL, KEROSENE, PETROL, PETROL ALCOHOL MIXED MAX 15%, AVGAS 100/100LL, JET A/A1 - ASPEN 2/4