



DISPENSERS



FUEL KITS



PUMPS



METERS



NOZZLE



FILTRATION

BATTERY KIT

FEATURES

- VERSATILITY
- MOBILE AND READY TO USE
- ON/OFF SWITCH

The PIUSI BATTERY KIT is a portable transfer unit with a self-priming electric vane pump. Its modular composition allows users to have different pumps according to the required flow rates and different applications. It is equipped with a fixed brush motor with permanent magnet stator and terminal board with switches and fuses to protect against overload. It is always supplied with integrated nozzle and a set of accessories.

PERFORMANCE

UP TO

12 GPM

FLOW RATE

12/24V

VOLTAGE

POWER

30 MIN

DUTY CYCLE

UP TO

6.5 FT

SELF-PRIMING



BATTERY KIT 3000



PACKAGING

PART #	WEIGHT		PACKAGING			N. BOXES / EUROPALLET	
	KG	LBS	MM	INCH	PCS/BOX		
FO022500C	7.8	17.3	300X300X180	12X12X7	1	50	100
FO022600C	7.8	17.3	300X300X180	12X12X7	1	50	100



FLUID
MONITORING



AIR



ANTIFREEZE



DEF



BIODIESEL



DIESEL



FOOD



GASOLINE



GREASE



KEROSENE



OIL



WATER



WINDSCREEN

CHART

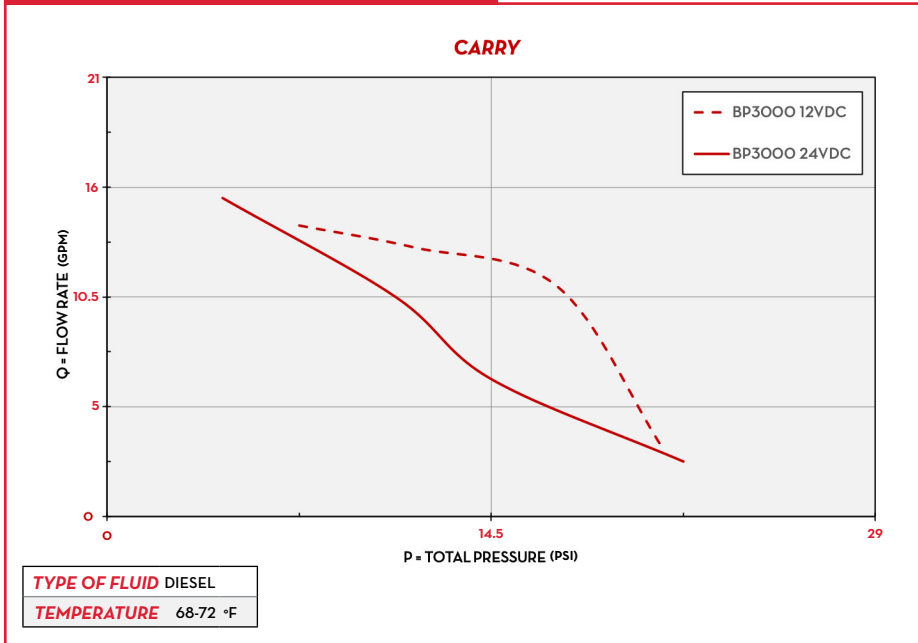

IN THE BOX

- PUMP
- SUCTION HOSE
- DELIVERY HOSE
- HANDLE
- NOZZLE
- MESH FILTER AND CONNECTIONS
- CABLES
- INSTRUCTION MANUAL

DETAILS

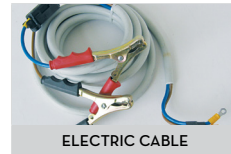

DIMENSIONS

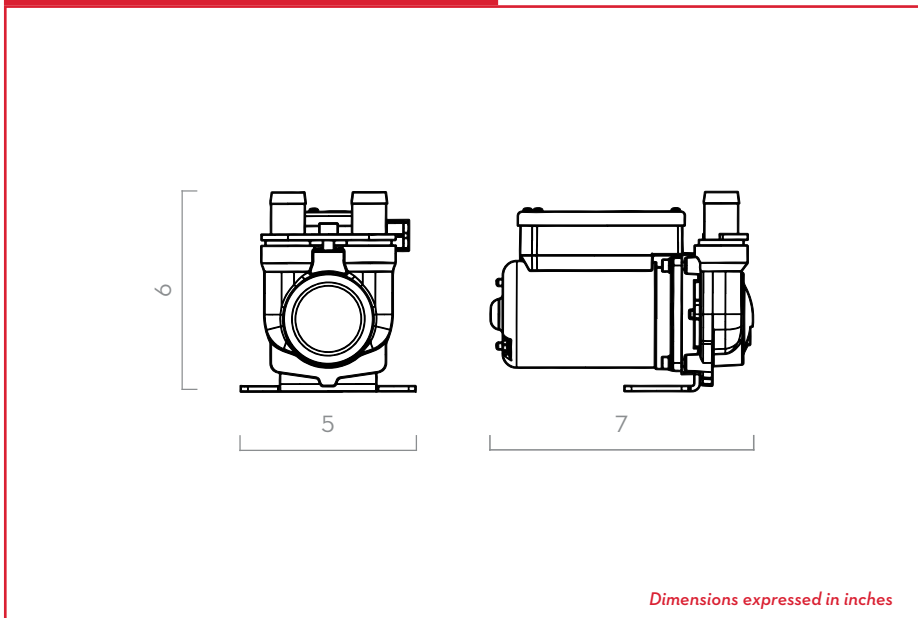

MATERIALS

- BODY: CAST IRON
- ROTOR: SINTERED STEEL
- VANES: ACETAL RESIN
- SEAL: NBR
- SHAFT: STEEL

TECHNICAL DATA

PART #	DESCRIPTION	FLUIDS TYPE	FLOW RATE		VOLTAGE			FUSES CAPACITY	PUMP TYPE	DUTY CYCLE MINUTES	NOZZLE TYPE	HOSE		CHECK FILTER
			L/MIN	GPM	AC V/ HZ	DC VOLT	POWER WATT					AMP. MAX.	LENGTH	
FOO22500C	BATTERY KIT 3000 12V 12GPM (MANUAL)	D	45	12	12	220	22	25	CARRY 3000 12V	30 ON/OFF	MAN.	13 FT	3/4"	YES
FOO22600C	BATTERY KIT 3000 24V 12GPM (MANUAL)	D	45	12	24	310	13	15	CARRY 3000 24V	30 ON/OFF	MAN.	13 FT	3/4"	YES

BATTERY KIT