



DISPENSERS



FUEL KITS



PUMPS



METERS



NOZZLE



FILTRATION

PITSTOP

FEATURES

- **READY TO INSTALL**
- **VERSATILITY**
- **STURDY STRUCTURE**

The PIUSI PITSTOP is a dispenser unit with two DC pumps, automatic hose reel, water filter and automatic nozzle with 14 meter. hose integrated into a sturdy supporting structure. Easy to install, versatile and compact, this dispenser is the all-in-one solution for setting up a perfect mobile refueling unit.

PERFORMANCE

UP TO

15 GPM

FLOW RATE

12V DC

VOLTAGE

POWER

50 FT

HOSE LENGTH

HOSE REEL

200β/30μ

FILTRING CAPACITY



PITSTOP DC



PACKAGING

PART #	WEIGHT		PACKAGING		
	KG	LBS	MM	INCH	PCS/BOX
FOO212020	45	99	595X465X670	23.4X13.5X24.4	1



FLUID
MONITORING

- A
AIR
- A
ANTIFREEZE
- D
DEF
- B
BIODIESEL
- D
DIESEL**
- F
FOOD
- G
GASOLINE
- G
GREASE
- K
KEROSENE
- O
OIL
- W
WATER
- W
WINDSCREEN

CHART

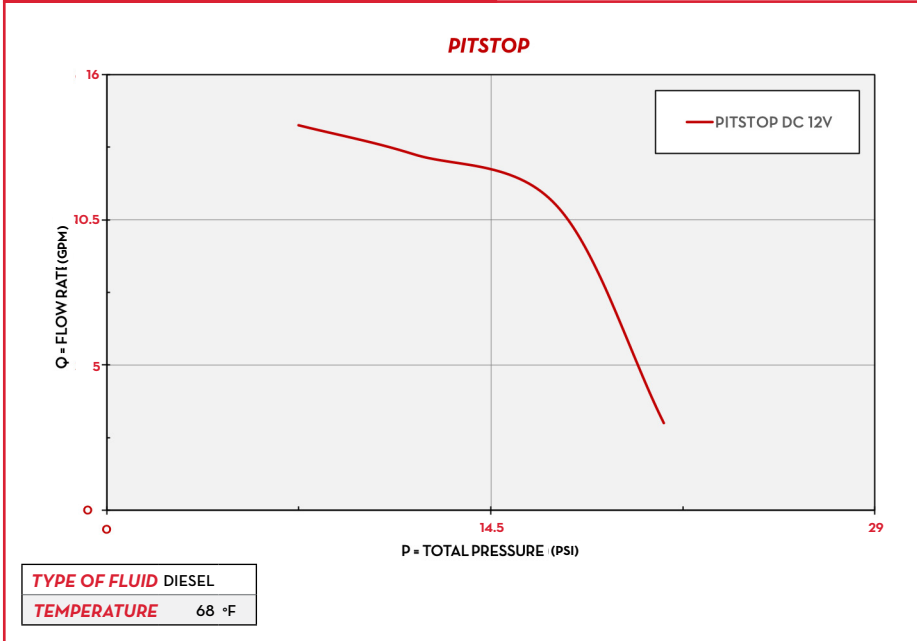

IN THE BOX

- PITSTOP UNIT
- AUTOMATIC NOZZLE
- FILTER
- INSTRUCTION MANUAL

DETAILS

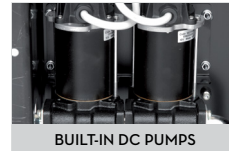

DIMENSIONS

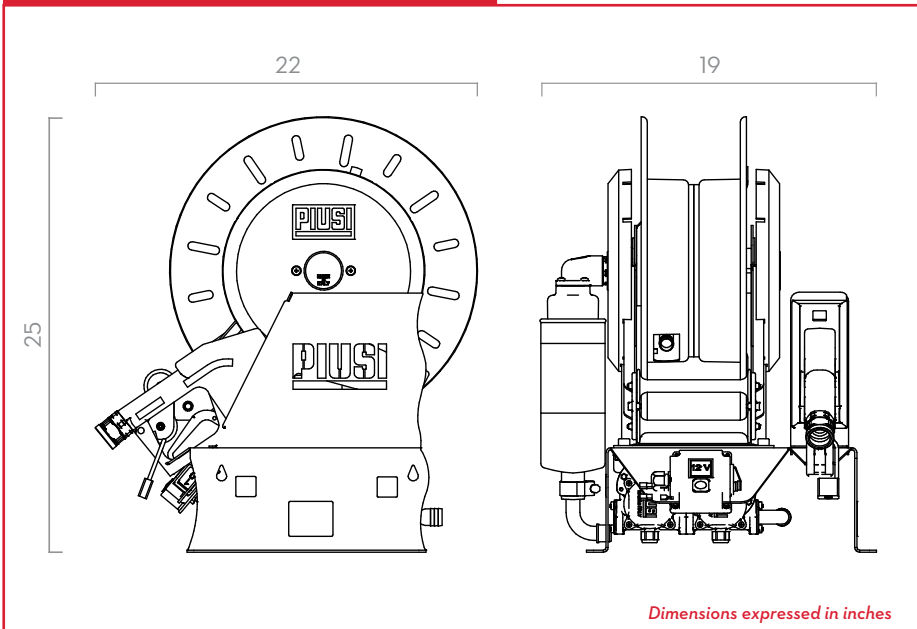

COMPONENTS

- **PUMP:**
BP3000
- **FILTER:**
WATER CAPTOR PG. 94
- **NOZZLE:**
A60 AUTOMATIC NOZZLE PG. 86

TECHNICAL DATA

PART #	DESCRIPTION	FLUIDS TYPE	FLOW RATE		VOLTAGE			PUMP		DUTY CYCLE	NOZZLE	HOSE		INLET
			L/MIN	GPM	AC V./HZ DC VOLT	POWER WATT	AMP. MAX.	TYPE	N°			LENGTH	Ø	
FOO212020	PITSTOP 12V 15GPM 50FT REEL(AUTO/FILTER)	D	56	15	12	400	33	BP 3000	2	30 ON/OFF	AUTO	50 FT	3/4"	1"