



DISPENSERS



PUMPS



METERS



METERED NOZZLES



NOZZLES

# MP 190

## FEATURES

- IN/OUT INTERCHANGEABLE
- LONG LIFE DIAPHRAGM
- BUILT-IN DIFFUSER
- SUITABLE FOR SUBMERSIBLE INSTALLATIONS
- HEAVY DUTY
- MULTI-PURPOSE PUMP
- STURDY DESIGN

The Piusi MP 190 is a pneumatic multi-purpose DEF diaphragm pump. The sturdy central technopolymer body makes this pump suitable for any heavy duty usage.



## PERFORMANCE

UP TO

**58 GPM**

FLOW RATE

MAX CAPACITY

**20 FT**

SELF PRIMING

MAX

**101 PSI**

AIR SUPPLY

PRESSURE

MAX

**Ø 0.16"**

PASSING SOLID

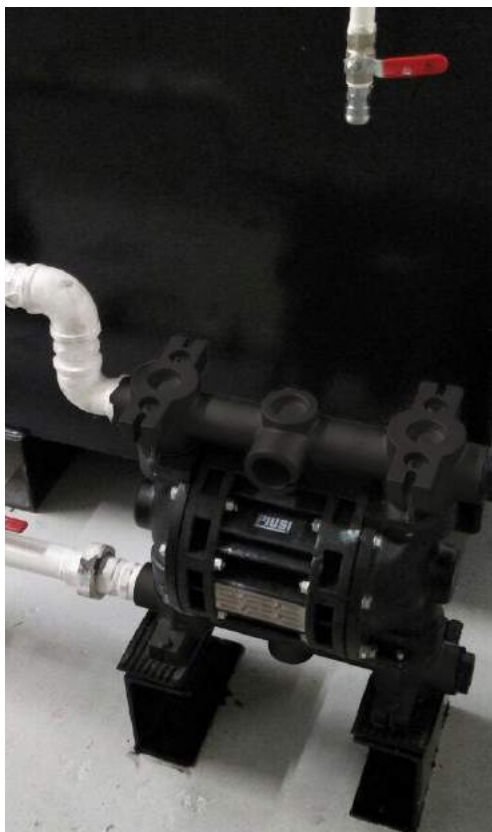

MP190

## PACKAGING

PART #	WEIGHT		PACKAGING		
	KG	LBS	MM	INCH	PCS/BOX
FOO208P60	13	29	483X483X305	19X19X12	1

CHARTS

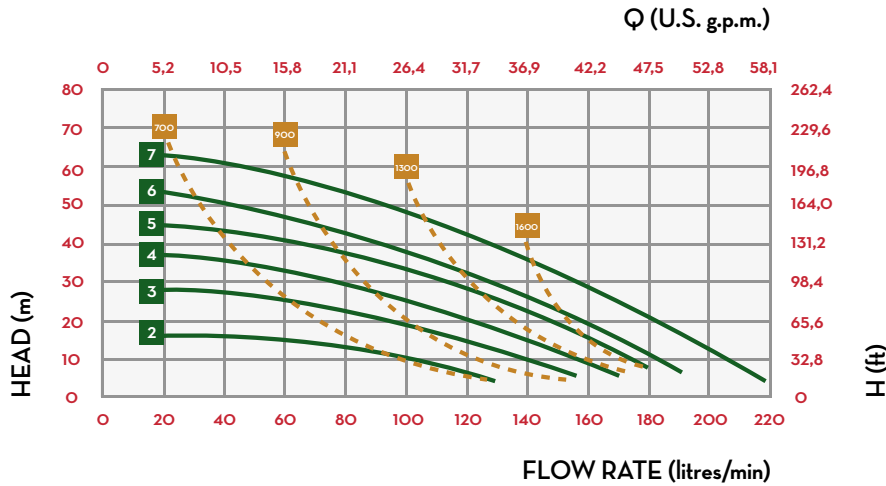

IN THE BOX

- MP PUMP
- INSTRUCTION MANUAL

DETAILS



MATERIALS

- BODY: TECHNOPOLYMER
- SIDE PARTS AND COLLECTORS: POLYPROPYLENE
- DIAPHRAGM: EPDM

DIMENSIONS

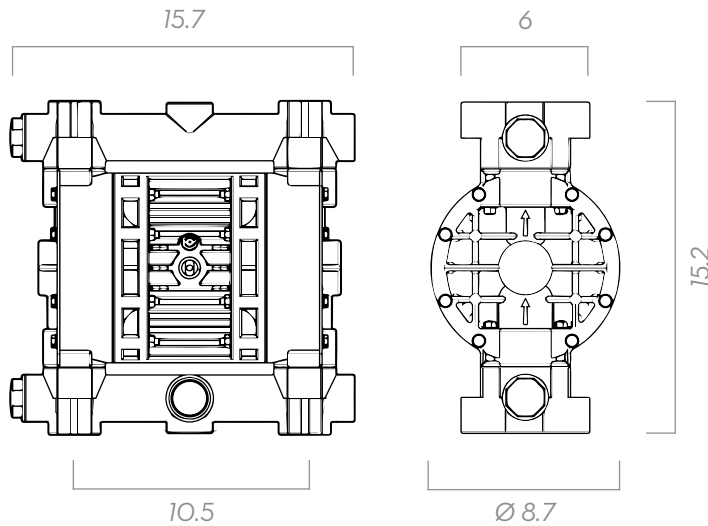

Dimensions expressed in inches

TECHNICAL DATA

PART #	DESCRIPTION	FLUIDS TYPE	PUMP BODY	IN / OUT NPT	FLOW RATE GPM	MEMBRANE TYPE	DIAPHRAGM AIR SIDE/ FLUID SIDE	BALLS	BALL SEATS*	O-RING*	INTAKE / DELIVERY CONNECTION	AIR CONNECTION	MAX SELF-PRIMING CAPACITY	MAX HEAD**	MAX AIR SUPPLY PRESSURE	MAX Ø OF PASSING SOLID
													FT	FT	PSI	IN
FOO208P60	MP190 DD AIR-OPERATED DEF PUMP 58GPM		POLYPROPYLENE	1-1/4"	58	DOUBLE	PTFE/ HYTREL	PTFE	POLYPROPYLENE	PTFE	G 1/4" F	G 1/2" F	20	230	101	0.16

(\*) ON REQUEST WE CAN PROVIDE MEMBRANES, BALLS, BALL SEATS AND O-RINGS IN DIFFERENT MATERIALS.  
 (\*\*\*) THE VALUE DEPENDS ON THE CONFIGURATION OF THE PUMP