



DISPENSERS



PUMPS



METERS



METERED NOZZLES



NOZZLES

SUZZARABLU PUMP DC

FEATURES

- **READY TO USE**
- **MULTI-PURPOSE PUMP**
- **SELF-PRIMING**
- **BUILT-IN BYPASS VALVE**

The Piusi SUZZARABLU DC PUMP is an electric DC diaphragm pump suitable for transferring DEF. This self-priming pump is equipped with a built-in pressure bypass.

PERFORMANCE

UP TO

9 GPM

FLOW RATE

20 MIN

DUTY CYCLE



SUZZARABLU PUMP DC

PACKAGING

PART #	WEIGHT		PACKAGING		N. BOXES/EUROPALLET	
	KG	LBS	MM	PCS/BOX		
FOO204080	4.5	10	14X11X8	1	60	84
FOO204090	4	9	14X11X8	1	60	84
FOO20402A	4.5	10	14X11X8	1	60	84



FILTRATION



FLUID MONITORING



HOSE REELS



ACCESSORIES



AIR



ANTIFREEZE



DEF



BIODIESEL



DIESEL



FOOD



GASOLINE



GREASE



KEROSENE



OIL



WATER



WINDSCREEN

CHARTS

SUZZARBLUE DC

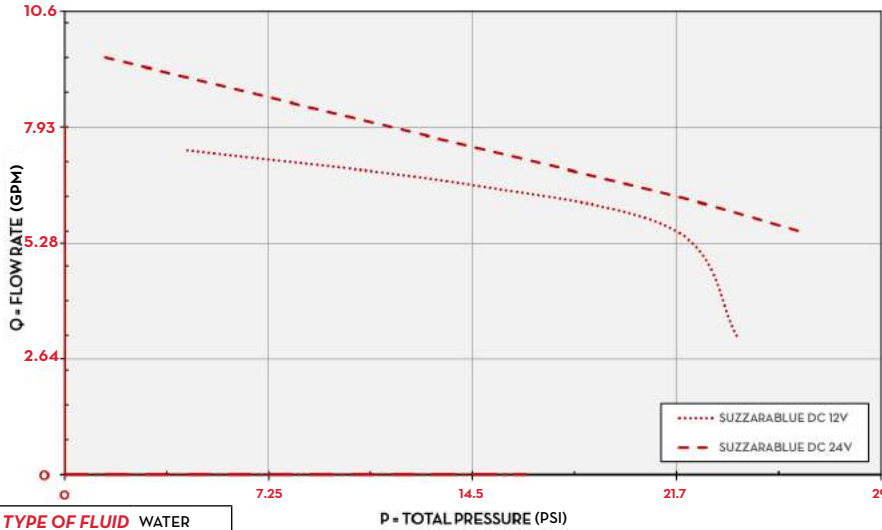

TYPE OF FLUID WATER
 TEMPERATURE 68 °F

IN THE BOX

- SUZZARBLUE PUMP
- CLAMPS
- INSTRUCTION MANUAL

DETAILS



ON/OFF SWITCH



CLAMPS

DIMENSIONS

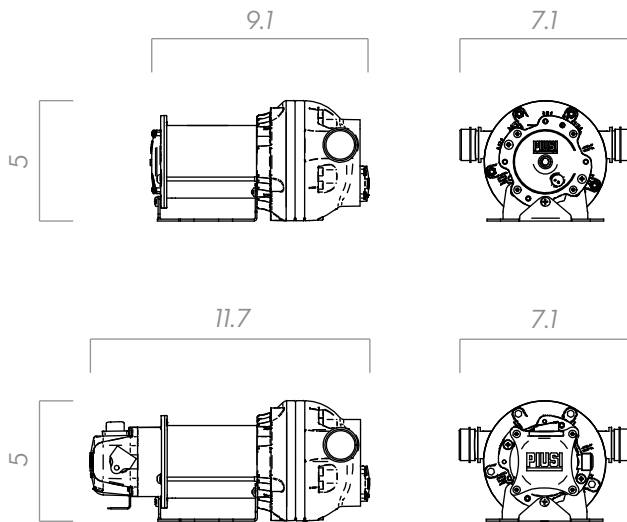

Dimensions expressed in inches

MATERIALS

- BODY: POLYPROPYLENE
- DIAPHRAGM: POLYPROPYLENE

TECHNICAL DATA

PART #	DESCRIPTION	FLUIDS TYPE	FLOW RATE		VOLTAGE			CABLES	INLET-OUTLET	ON/OFF	
			L/MIN	GPM	AC V/HZ DC VOLT	RPM	POWER WATT				AMP. MAX.
FOO204080	SUZZARBLUE 12V DEF DIAPHRAGM PUMP		34	9	12	2800	260	22	YES	3/4"	YES
FOO204090	SUZZARBLUE 24V DEF DIAPHRAGM PUMP		34	9	24	2800	310	13	YES	3/4"	YES
FOO20402A	SUZZARBLUE 12V DEF PUMP (18FT CABLE)		34	9	12	2800	260	22	18 FT	3/4"	YES

SUZZARBLUE PUMP DC