



## Operating Instructions & Parts Manual



### Model 9681115



## 6" x 9" Belt/Disc Sander





**GETTING STARTED**

***Please read and save these instructions. Read carefully before attempting to assemble, install, operate or maintain the product described.***

***Protect yourself and others by observing all safety information. Failure to comply with instructions could result in personal injury and/or property damage! retain instructions for future reference.***

**SAFETY / SPECIFICATIONS**

**ASSEMBLY / INSTALLATION**

**OPERATION**

**TROUBLESHOOTING**

**MAINTENANCE / REPAIR**

**Model #:** \_\_\_\_\_

**Serial #:** \_\_\_\_\_

**Purchase Date:** \_\_\_\_\_





## GETTING STARTED

### Structural Requirements

Make sure all supporting structures and load attaching devices are strong enough to hold your intended loads. If in doubt, consult a qualified structural engineer.

### Electrical Requirements

The power supply to the Sander needs to be 120 volt/ 8.0 amp, single phase, 60 Hz. The standard allowable voltage variation is plus or minus 10%.

### Tools Needed:

Standard mechanic's hand tool set.

## UNPACKING

**⚠ WARNING** *Be careful not to touch overhead power lines, piping, lighting, etc. if lifting equipment is used. Sander weighs approximately 88 lbs, proper tools, equipment and qualified personnel should be employed in all phases of unpacking and installation.*

Cartons should be handled with care to avoid damage from dropping, bumping, etc. Store and unpack cartons with correct side up. After unpacking Sander, inspect carefully for any damage that may have occurred during transit. Check for loose, missing or damaged parts. If any damage or loss has occurred, claim must be filed with carrier immediately. Check for completeness. Immediately report missing parts to dealer.

Sander is shipped partially assembled. End user will need to assemble loose parts to machine.

**IMPORTANT:** The tool has been coated with a protective coating. In order to ensure proper fit and operation, the coating must be removed. Remove coating with mild solvents such as mineral spirits and a soft cloth. Nonflammable solvents are recommended. After cleaning, cover all exposed metal surfaces with a light coating of oil.

**⚠ CAUTION** *Never use highly volatile solvents. Avoid getting cleaning solution on paint as it may tend to deteriorate these finishes. Use soap and water on painted components.*

### Contents:

- Sander (1)
- Miter gauge assembly (1)
- Fence support (1)
- Table assembly (1)
- Hardware bag (1)
- Rubber foot (4)
- Hex wrench (1)
- Operating Instructions and Parts Manual (1)

### Unpack:

- Carefully unpack Sander from carton. Do not discard packing materials until after machine has been inspected for damage and completeness. Locate loose parts and set aside.

### Inspect:

- After unpacking the unit, carefully inspect for any damage that may have occurred during transit. Check for loose, missing or damaged parts. Shipping damage claims must be filed with the carrier.
- All tools should be visually inspected before use, in addition to regular periodic maintenance inspections.
- Be sure that the voltage labeled on the unit matches your power supply.



- See General Safety Instructions, Cautions and Warnings as shown.

## SAFETY RULES

**⚠ WARNING** *For your own safety, read all of the instructions and precautions before operating tool.*



**PROPOSITION 65 WARNING:** Some dust created by using power tools contain chemicals known to the state of California to cause cancer, birth defects or other reproductive harm.

Some examples of these chemicals are:

- Lead from lead-based paints.
- Crystalline silica from bricks and cement and other masonry products.
- Arsenic and chromium from chemically-treated lumber.

Your risk from these exposures varies, depending on how often you do this type of work. To reduce your exposure to these chemicals: work in a well ventilated area and work with approved safety equipment. Always wear OSHA/NIOSH approved, properly fitting face mask or respirator when using such tools.

**⚠ WARNING** *Always follow proper operating procedures as defined in this manual even if you are familiar with the use of this or similar tools. Remember that being careless for even a fraction of a second can result in severe personal injury.*

### Be Prepared for Job

- Wear proper apparel. Do not wear loose clothing, gloves, neckties, rings, bracelets or other jewelry which may get caught in moving parts of machine.
- Wear protective hair covering to contain long hair.
- Wear safety shoes with non-slip soles.
- Wear safety glasses complying with United States ANSI Z87.1. Everyday glasses have only impact resistant lenses. They are **NOT** safety glasses.



**SAFETY RULES (CONTINUED)**

- Wear face mask or dust mask if operation is dusty.
- Be alert and think clearly. Never operate power tools when tired, intoxicated or when taking medications that cause drowsiness.

**Prepare Work Area for Job**

- Keep work area clean. Cluttered work areas invite accidents.
- Do not use power tools in dangerous environments. Do not use power tools in damp or wet locations. Do not expose power tools to rain.
- Work area should be properly lighted.
- Proper electrical receptacle should be available for tool. Three-prong plug should be plugged directly into properly grounded, three-prong receptacle.
- Extension cords should have a grounding prong and the three wires of the extension cord should be of the correct gauge.
- Keep visitors at a safe distance from work area.
- Keep children out of workplace. Make workshop childproof. Use padlocks, master switches or remove switch keys to prevent any unintentional use of power tools.

**Tool Should Be Maintained**

- Always unplug tool prior to inspection.
- Consult manual for specific maintaining and adjusting procedures.
- Keep tool lubricated and clean for safest operation.
- Remove adjusting tools. Form habit of checking to see that adjusting tools are removed before switching machine on.
- Keep all parts in working order. Check to determine that the guard or other parts will operate properly and perform their intended function.
- Check for damaged parts. Check for alignment of moving parts, binding, breakage, mounting and any other condition that may affect a tool's operation.
- A guard or other part that is damaged should be properly repaired or replaced. Do not perform makeshift repairs. (Use parts list provided to order repair parts.)

**Know How to Use Tool**

- Use right tool for job. Do not force tool or attachment to do a job for which it was not designed.
- Disconnect tool when changing the belt or abrasive disc.
- Avoid accidental start-up. Make sure that the tool is in the OFF position before plugging in.
- Do not force tool. It will work most efficiently at the rate for which it was designed.

- Keep hands away from moving parts and sanding surfaces.
- Never leave tool running unattended. Turn the power off and do not leave tool until it comes to a complete stop.
- Do not overreach. Keep proper footing and balance.
- Never stand on tool. Serious injury could occur if tool is tipped or if blade is unintentionally contacted.
- Know your tool. Learn the tool's operation, application and specific limitations.
- Use recommended accessories. Use of improper accessories may cause risk of injury to persons.
- Handle workpiece correctly. Protect hands from possible injury.
- Turn machine off if it jams. Belt jams when it digs too deeply into workpiece. (Motor force keeps it stuck in the work.)
- Support workpiece with miter gauge, belt platen or work table.
- Maintain 1/16" maximum clearance between table and sanding belt or disc.

**▲ CAUTION** *Think safety! Safety is a combination of operator common sense and alertness at all times when tool is being used.*

**▲ WARNING** *Do not attempt to operate tool until it is completely assembled according to instructions.*

**SPECIFICATIONS**

Belt size	6 x 48"
Belt platen area	6 x 14½"
Belt drum dimensions	2⅞ x 6⅛"
Table dimensions	6 x 11½"
Table tilts	0 to 45°
Dust chute diameter	2"
Belt speed	1836 SFPM
Disc diameter	9"
Disc speed	2510 RPM
Base dimensions	12 x 18⅛"
Switch	SP, Locking rocker
Motor	1 HP, 120 V, 8.0 Amps
Weight	72 lbs
Shipping weight	76 lbs





## ASSEMBLY

**CAUTION** Do not attempt assembly if parts are missing. Use this manual to order repair parts.

**WARNING** the sander must NOT be plugged in and the power switch must be in the "OFF" position until assembly is complete.

### Installing the Foot Pads

Four rubber foot pads are supplied to protect your work surface, and to reduce any vibration that may develop when the sander is operating.

1. Tilt the sander up and slide the feet onto each of the four corners of the sander. No hardware is needed. See Figure 1.

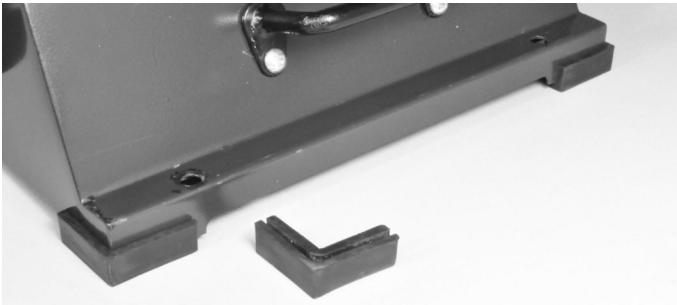

Figure 1 - Install foot pads.

### Installing the Sanding Belt Fences

The sander includes two fences for use with the sanding belt. The small fence/platen attaches directly to the sanding belt frame, and is used for supporting small items being sanded.

The larger fence/platen attaches onto the small fence. It gives a larger support surface for sanding large work pieces.

**NOTE:** These parts may be pre-assembled at the time of delivery. If not, follow the following parts assembly:

1. Install the small fence onto the sanding belt frame with the four hex screws and washers. See Figure 2.



Figure 2 - Install small fence.

2. Insert two star-head screws through the countersunk holes in the large fence and install the knobs on their threaded ends. (Washers shown in Figure 3 are optional, not included with sander).

3. Slide the large fence's two screws with knobs over the two slots in the small fence and fasten in place. Pending on the material being sanded, the large fence can easily be removed by just loosening the two knobs and sliding it off the small fence. See Figure 3.

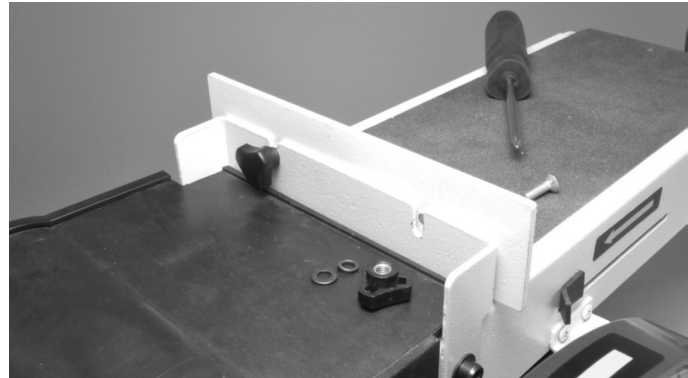

Figure 3 - Install fence knobs.

### Installing the Disc Table

Refer to figures 4 and 5.

The larger worktable is used with the sanding disc. It should be used to support workpieces in all sanding operations except inside curve applications.

1. Locate worktable handles and washers in parts bag.
2. Place the worktable onto the sander frame, aligning the semi-circle slot with the threaded hole.
3. Place a washer on threaded shaft of each worktable handle, insert through semi-circular slot, and tighten into threaded hole. Repeat on other side of table.
4. Adjust worktable to level or any angle between 0° and 45° for sanding.

**NOTE:** Always check to make sure the handles are tight before beginning any sanding operation.

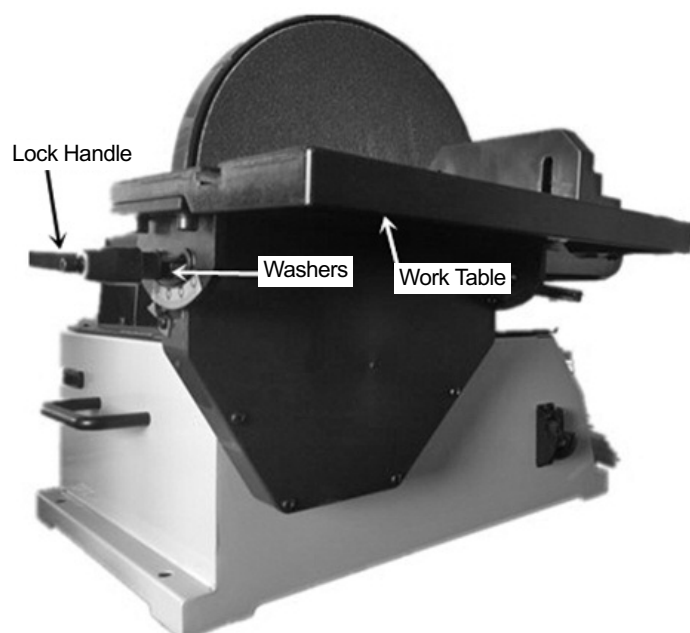

Figure 4





## ASSEMBLY (CONTINUED)

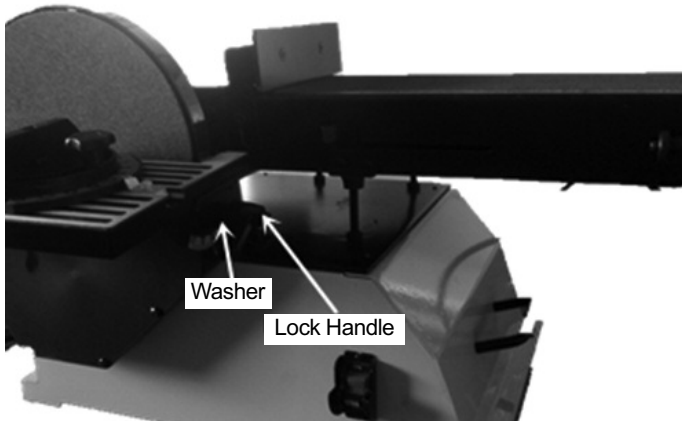

Figure 5

### Mounting PSA Sandpaper Disc

**NOTE:** The 6 x 9" Belt Disc Sander only uses 9" diameter abrasive sanding discs with Pressure Sensitive Adhesive (PSA) backing. To apply the sandpaper:

1. The metal disc plate is pre-installed on the machine. Locate the 9" PSA sandpaper disc and peel the protective backing off.
2. Center the sandpaper over the metal disc plate, then press the sandpaper firmly in place. See Figure 6.

See page 9 for instructions on changing the sandpaper disc.



Figure 6 - Mount sandpaper disc.

**⚠ WARNING** *Before plugging in and turning on the machine, mount the sander and complete all of the adjustments in the instructions that follow. This will ensure that the sander is correctly set up for safe and efficient operation.*

## INSTALLATION

**⚠ WARNING** *The machine must not be plugged in and the power switch must be in the off position until all adjustments are complete.*

### Mount Sander

**NOTE:** Although compact, the sander is heavy. At least two people are required to lift from carton.

Choose a suitable location to mount the sander. The sander must be installed in a place with ample lighting and correct power supply.

Make sure there is plenty of room for moving the workpiece. There must be enough room that neither operators nor bystanders will have to stand in line with the wood while using the tool. Allow room so that belt assembly can be positioned horizontally.

Figure 7 shows the base dimensions, mounting holes and required space to allow for table assembly and belt assembly in horizontal position.

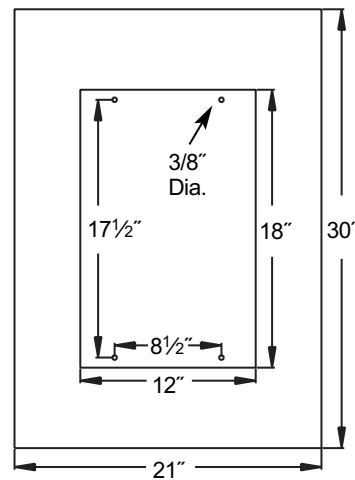

Figure 7 - Base dimension and required space.

The sander must be bolted to a firm, level surface. Sander can be installed on a workbench or a tool stand using bolts, lock washers and hex nuts (not supplied).





## INSTALLATION (CONTINUED)

### Adjusting Disc Table Angle

Ensure sander is disconnected from the power supply prior to commencing work.

1. To check the trueness of the 90° angle of the disc sanding table, place a square or other measuring device on the table with the other end against the sanding disc. See Figure 8.

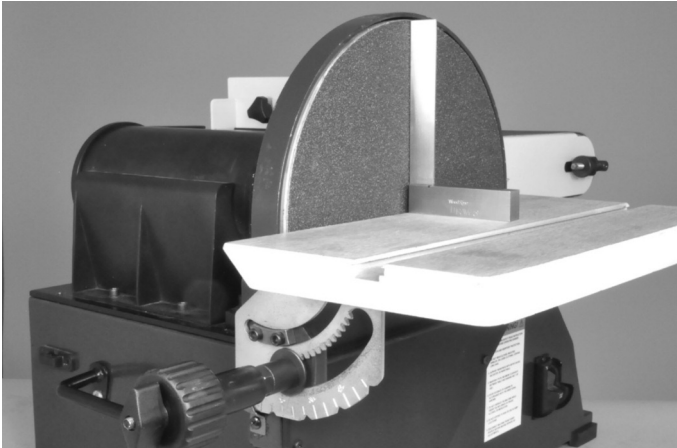

**Figure 8 - Check disc trueness.**

2. Loosen the disc table adjustment handle, and adjust table angle to 90°.
3. Re-tighten the disc table adjustment handle.
4. Adjust the angle scale pointer to 0°.
5. To adjust the disc table to another angle, loosen the disc table adjustment handle.
6. Set the table at the desired angle using the angle scale pointer.
7. Re-tighten the disc table adjustment handle.

**▲ WARNING** *To avoid jamming the work piece or fingers between the table and sanding surface, the table edge should be set to a maximum of 1/16 inches away from sanding surface. See Figure 9.*

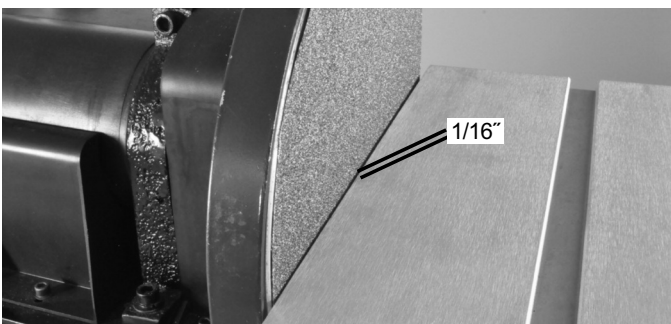
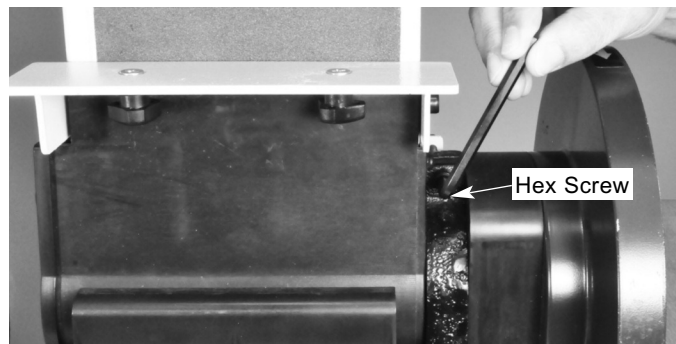

**Figure 9**

### Adjusting Belt Assembly Position

The sanding belt frame can be easily adjusted from a horizontal position to a vertical position, or any other position to assist your sanding operation.

1. Loosen the hex screw that pulls the split casting together. This allow the sanding belt frame to be moved to the work angle desired. See Figure 10.



**Figure 10**

2. Once the sanding belt frame is at the desired work angle, re-tighten the hex screw to secure it in place.
3. In the horizontal position, there are two vertical padded hex screws that support the sanding belt frame. These should be checked and adjusted, if necessary, to make sure that they both touch the sanding belt frame supports. These screws will help relieve pressure on the casting during work. See Figure 11.

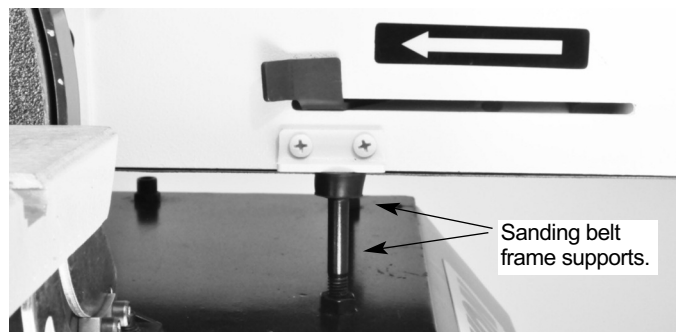

**Figure 11**



**INSTALLATION (CONTINUED)**

**▲ WARNING** *All electrical connections must be performed by a qualified electrician.*

**Power Source**

Connect sander to a supply circuit protected by a circuit breaker or time-delay fuse.

The motor is designed for operation on the voltage and frequency specified. Normal loads will be handled safely on voltages not more than 10% above or below the specified voltage.

Running the unit on voltages which are not within the range may cause overheating and motor burn-out. Heavy loads require that the voltage at motor terminals be no less than the voltage specified. Power supply to the motor is controlled by a single pole locking rocker switch. Remove the key to prevent unauthorized use.

**Grounding Instructions**

**▲ WARNING** *Improper connection of equipment grounding conductor can result in the risk of electrical shock. Equipment should be grounded while in use to protect operator from electrical shock.*

Check with a qualified electrician if grounding instructions are not understood or if in doubt as to whether the tool is properly grounded.

This tool is equipped with an approved 3-conductor cord rated at 300V and a 3-prong grounding type plug (See Figure 15) for your protection against shock hazards.

Grounding plug should be plugged directly into a properly installed and grounded 3-prong grounding-type receptacle, as shown (Figure 12).

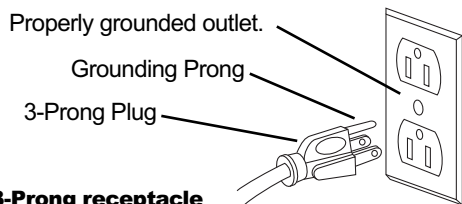

**Figure 12 – 3-Prong receptacle**

Do not remove or alter grounding prong in any manner. In the event of a malfunction or breakdown, grounding provides a path of least resistance for electrical shock.

**▲ WARNING** *Do not permit fingers to touch the terminals of plug when installing or removing from outlet.*

Plug must be plugged into matching outlet that is properly installed and grounded in accordance with all local codes and ordinances. Do not modify plug provided. If it will not fit in outlet, have proper outlet installed by a qualified electrician.

Inspect tool cords periodically, and if damaged, have repaired by an authorized service facility.

Green (or green and yellow) conductor in cord is the grounding wire. If repair or replacement of the electric cord or plug is necessary, do not connect the green (or green and yellow) wire to a live terminal.

Where a 2-prong wall receptacle is encountered, it must be replaced with a properly grounded 3-prong receptacle installed in accordance with National Electric Code and local codes and ordinances.

**▲ WARNING** *This work should be performed by a qualified electrician.*

A temporary 3-prong to 2-prong grounding adapter (See Figure 13) is available for connecting plugs to a two pole outlet if it is properly grounded.

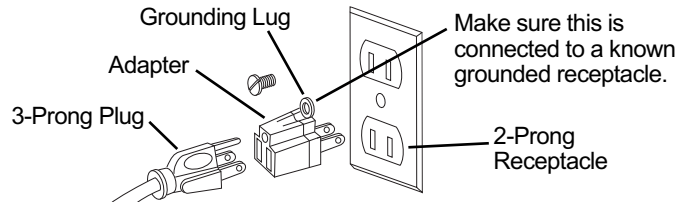

**Figure 13 – 2-Prong receptacle with adapter**

Do not use a 3-prong to 2-prong grounding adapter unless permitted by local and national codes and ordinances.

(A 3-prong to 2-prong grounding adapter is not permitted in Canada.) Where permitted, the rigid green tab or terminal on the side of the adapter must be securely connected to a permanent electrical ground such as a properly grounded water pipe, a properly grounded outlet box or a properly grounded wire system.

Many cover plate screws, water pipes and outlet boxes are not properly grounded. To ensure proper ground, grounding means must be tested by a qualified electrician.

**Extension Cords**

- The use of any extension cord will cause some drop in voltage and loss of power.
- Wires of the extension cord must be of sufficient size to carry the current and maintain adequate voltage.
- Use the table to determine the minimum wire size (A.W.G.) extension cord.
- Use only 3-wire extension cords having 3-prong grounding type plugs and 3-pole receptacles which accept the tool plug.
- If the extension cord is worn, cut or damaged in any way, replace it immediately.

**Extension Cord Length**

Length	Wire Size A.W.G.
Up to 25 ft	18
25 – 50 ft	16

**NOTE:** Using extension cords over 50 ft. long is not recommended.





## OPERATION

**⚠ WARNING** *Operation of any power tool can result in foreign objects being thrown into eyes which can result in severe eye damage. Always wear safety goggles complying with United States ANSI Z87.1 before commencing power tool operation. Safety goggles are available through your Grainger catalog.*

**⚠ CAUTION** *Always observe the following safety precautions:*

- Whenever adjusting or replacing any parts on the tool, turn switch off and remove the plug from power source.
- Recheck table handles and bolt. They must be tightened securely.
- Make sure all guards are properly attached and securely fastened.
- Make sure all moving parts are free and clear of any interference.
- Make sure all fasteners are tight and have not vibrated loose.
- With power disconnected, test operation by hand to verify clearance and adjust if necessary.
- Always wear eye protection or face shield.
- Make sure abrasive belt tracks properly. Correct tracking gives optimum performance.
- After turning switch on, always allow belt to come up to full speed before sanding or grinding.
- Be sure disc turns counterclockwise. Abrasive belt must travel downward.
- Keep your hands clear of abrasive belt, disc and all moving parts.
- For optimum performance, do not stall motor or reduce speed. Do not force the work into the abrasive belt or disc.
- Always support workpiece with table or work stop when sanding with belt and with table when sanding with disc.
- Never push a sharp corner of workpiece rapidly against belt or disc. Abrasive backing may tear.
- Replace abrasive belt or disc when they become loaded (glazed) or frayed.

**⚠ WARNING** *Before turning on the machine, review all safety precautions. Make sure that you fully understand the features, adjustments and capabilities of the machine that are outlined throughout this manual.*

## ON/OFF Switch

The ON/OFF locking switch needs to have the safety switch key inserted before the switch can be used. This feature prevents unauthorized use of the sander. See Figure 14.



**Figure 14 - Remove safety key to prevent sander use.**

## Abrasive Belt Sanding

- **Finishing flat surfaces:** Hold workpiece firmly with both hands; keep fingers away from abrasive belt.  
Use table to position and secure work being sanded. Keep end butted against table and move work evenly across abrasive belt.
- **Finishing long pieces:** Use belt in horizontal position with work stop. Apply only enough pressure to allow abrasive belt to remove material.  
Use work stop to position and secure work being sanded. Keep end butted against work stop and move work evenly across abrasive belt. Use extra caution when finishing very thin pieces.
- **Finishing curved edges:** Finish outside curves on flat portion of abrasive belt. Finish inside curves on idler drum portion of abrasive belt.
- **Finishing end grain:** It is more convenient to finish ends of long workpieces with the abrasive belt in a vertical position.  
Position table on belt side of sander. Move work evenly across abrasive belt. For accuracy, use miter gauge. Table may be tilted for beveled work.

## Abrasive Disc Sanding

- Abrasive disc sanding is well suited for finishing small flat surfaces and convex edges.
- Move workpiece across down side (left) of abrasive disc. Hold workpiece firmly with both hands; keep fingers away from abrasive disc.
- Abrasive disc moves fastest and removes more material at outer edge.
- For accuracy, use miter gauge.





## OPERATION (CONTINUED)

### Changing the Sanding Belt

1. Remove the plastic side cover from the frame by unscrewing the knob. See Figure 15.

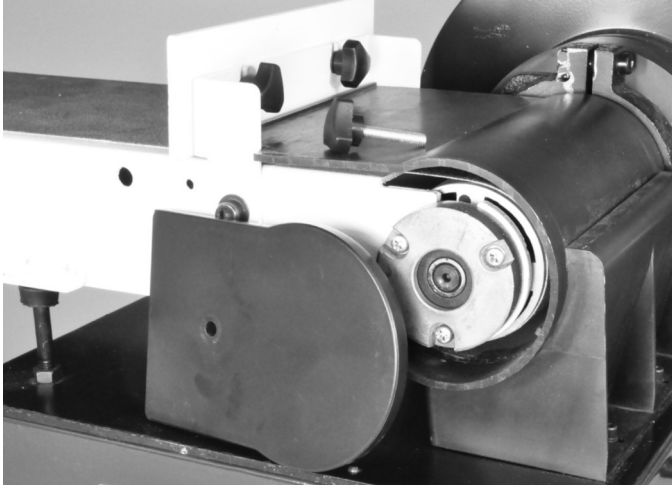

Figure 15

2. Remove the small fence. See page 3 for instructions on installing this part.
3. Slide tension lever to the right to release the belt tension. See Figure 16.

**NOTE:** Above the tension lever, there is a direction arrow. The sanding belt must run in the direction of this arrow so that the splice does not come apart. See figures 16 and 17.

4. Remove the old belt by sliding it off to the left of the frame. Place the new sanding belt over the drums with the direction arrow pointing in the proper direction. See Figure 17. Make sure the belt is centered on both drums.
5. Slide the tension lever to the left to apply tension to the belt. See Figure 16.
6. Re-install the small fence and side cover onto the frame (removed in Step 1 & 2).
7. Plug in the power cord. Turn the switch "ON" and note if the belt tends to move to the right or left on the drums. The belt should be running on the center of the drive drums. If it is not, the belt tracking needs adjustment. See instructions on sanding belt tracking.



Figure 16

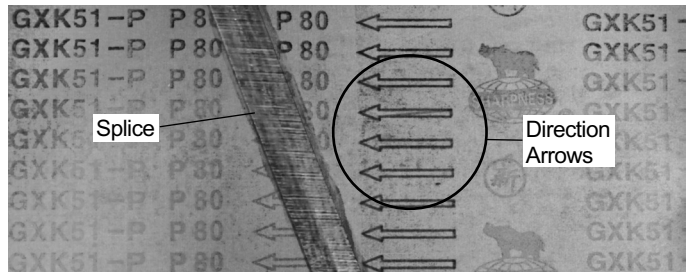

Figure 17

### Adjusting Sanding Belt Tracking

Refer to Figure 18.

1. Belt tracking on the center of the drive wheels is pre-set at the factory. If an adjustment needs to be made, the sander must be turned on.
  - a) If the sanding belt moves toward the disc, slowly turn the tracking knob clockwise 1/4 turn.
  - b) If the sanding belt moves away from the disc, turn the tracking knob slowly counterclockwise 1/4 turn.
2. Slowly turn the belt tracking knob noting the belt movement. Re-adjust the tracking knob, as necessary, until the belt runs true in the center of the drums.

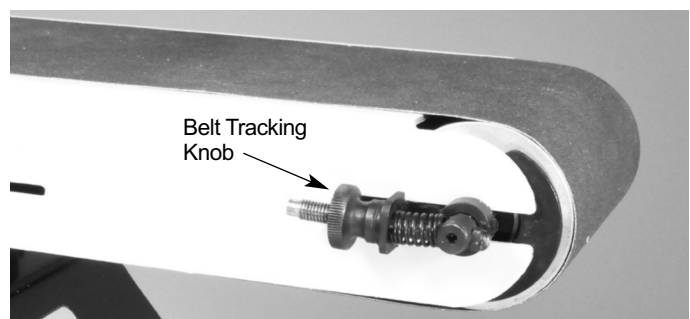

Figure 18



## OPERATION (CONTINUED)

### Changing the Sanding Disc

Refer to Figure 19.

The sandpaper disc can be removed with the table installed, or with the table removed to give more working access to the disc, if needed.

1. Peel the used abrasive disc from the metal disc plate. A putty knife may help in this process.
2. Make sure that the disc plate is clean of any residue. Mineral spirits will soften the PSA adhesives for its removal. Rotate the disc by hand to access to all of the disc surface.
3. Peel the protective backing from the new PSA 9" abrasive sanding disc, then center and press the sanding disc firmly onto the metal disc plate. See page 4.
4. Replace the sanding table if it was removed.



Figure 19

## MAINTENANCE

**⚠ WARNING** *Make certain that the unit is disconnected from power source before attempting to service or remove any component.*

### Cleaning

- Keep machine and workshop clean. Do not allow sawdust to accumulate on the tool.
- Keep the drums clean. Dirt on drums will cause poor tracking and belt slippage.
- Operate tool with dust collector to keep dust from accumulating.
- Be certain motor is kept clean and is frequently vacuumed free of dust.
- Use soap and water to clean painted parts, rubber parts and plastic guards.

### Lubrication

The shielded ball bearings in this tool are permanently lubricated at the factory. They require no further lubrication.

- When operation seems stiff, a light coat of paste wax applied to the belt and disc tables will make it easier to feed the work while finishing.
- Do not apply wax to the belt platen. Belt could pick up wax and deposit it on the drums causing belt to slip.

### Keep Tool in Repair

- If power cord is worn, cut or damaged in any way, have it replaced immediately.
- Replace worn abrasives when needed.
- Replace any damaged or missing parts. Use parts list to order parts.
- Any attempt to repair motor may create a hazard unless repair is done by a qualified service technician.



GETTING STARTED

SAFETY / SPECIFICATIONS

ASSEMBLY / INSTALLATION

OPERATION

TROUBLESHOOTING

MAINTENANCE / REPAIR

REPAIR PARTS ILLUSTRATION FOR 9681115 6" X 9" BELT/DISC SANDER

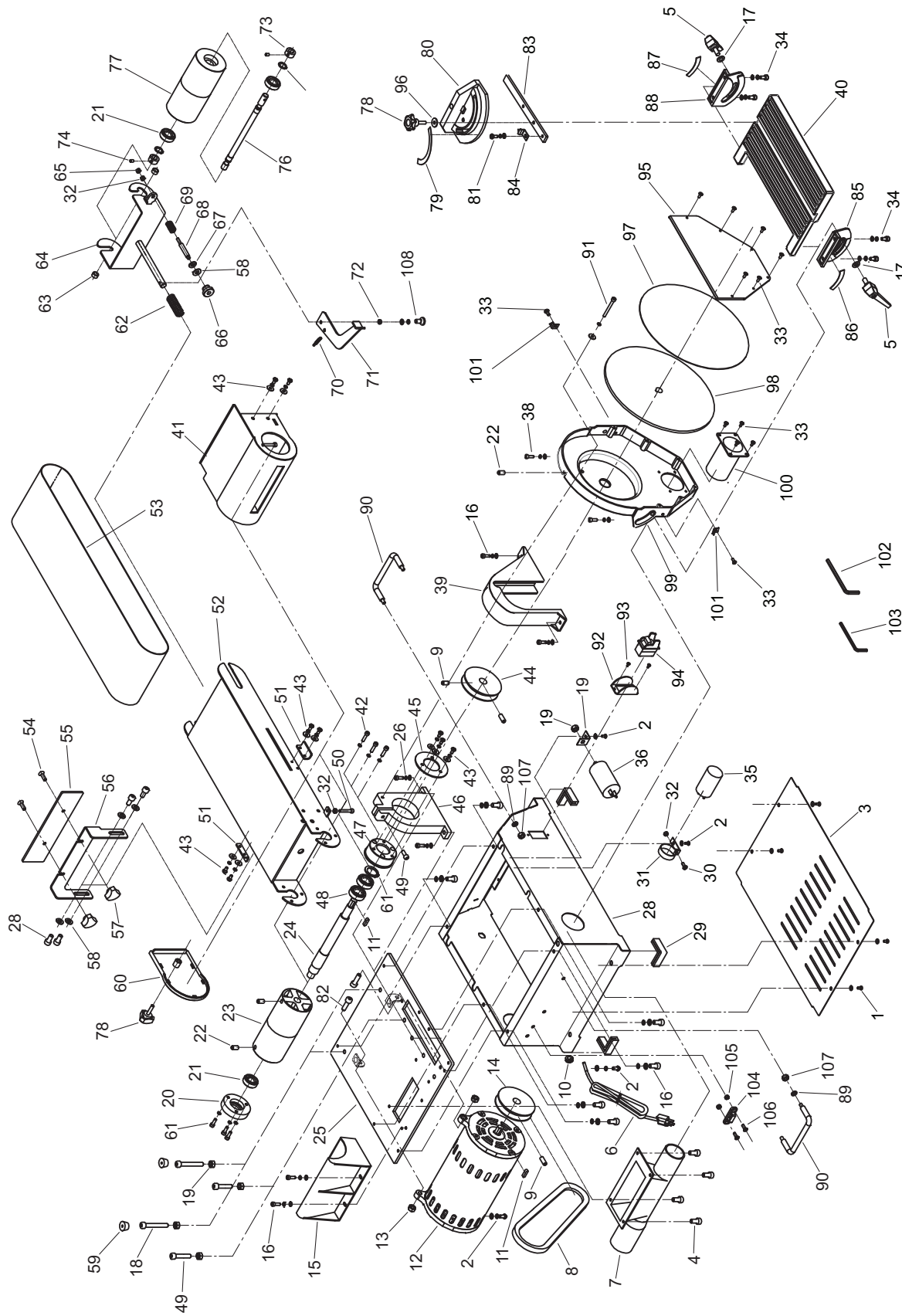

Figure 26 - Parts Illustration



**REPAIR PARTS LIST FOR 9681115 6" X 9" BELT/DISC SANDER**

Ref. No.	Description	Part No.	Qty.	Ref. No.	Description	Part No.	Qty.
1	Philips screw + flat washer M4x6	*	4	29	Rubber foot	9624672.01	4
2	Philips screw + spring washer + flat washer M4x8	*	4	30	Philips screw M5x12	*	1
3	Base Plate	9642862.01	1	31	Capacitor bracket	9642866.01	1
4	Philips Screw M5x8	*	4	32	Hex nut, I type M5	*	3
5	Lock handle	9642863.01	2	33	Philips screw M4x10	*	11
6	Power Cord	9624671.01	1	34	Hex screw + spring washer + flat washer M6x12	*	4
7	Dust hose	9642864.01	1	35	Capacitor 20UF/125V	9642867.01	1
8	V-belt A580	9642865.01	1	36	Capacitor 20UF/300V	9642868.01	1
9	Hex screw M6X8	*	5	37	Capacitor bracket	9642869.01	1
10	Cord clip 6P4	*	1	38	Hex screw + spring washer + flat washer M5x18	*	2
11	Key A5X15	*	2	39	Belt cover	9624638.01	1
12	Motor	9624652.01	1	40	Disc table	9642870.01	1
13	Nut M8	*	2	41	Dust port	9642871.01	1
14	Driving pulley	9624653.01	1	42	Philips screw + spring washer M5x25	*	3
15	Dust cover	9624637.01	1	43	Philips screw + spring washer + flat washer M5X12	*	9
16	Hex screw + spring washer + flat washer M5x10	*	10	44	Idler pulley	9624666.01	1
17	Flat washer D8	*	2	45	Fixing ring	9642872.01	1
18	Hex screw M8X55	*	2	46	Belt frame assembly base	9642873.01	1
19	Hex nut, I type M8	*	5	47	Bearing cap	9624639.01	1
20	Bearing cap	9624631.01	1	48	Ball bearing 6202	*	2
21	Ball bearing 6201	*	3	49	Hex screw M8x30	*	3
22	Hex screw M8X12	*	3	50	Hex screw M5x30	*	1
23	Driving drum	9621434.01	1	51	Supporting plate	9642874.01	2
24	Driving shaft	9624633.01	1	52	Platen	9624628.01	1
25	Supporting plate	NA	1	53	Sanding belt (6 x 48")	9622173.00	1
26	Hex screw + spring washer + flat washer M8X30	*	2	54	Philips screw, M6x14	*	2
27	Hex screw M8X16	*	4	55	Fence	9642875.01	1
28	Base	NA	1	56	Fence support	9642876.01	1

(Δ) Not shown.

(\*) Standard hardware item, available locally.

(NA) Not available as replacement part.



<b>MAINTENANCE / REPAIR</b>	<b>TROUBLESHOOTING</b>	<b>OPERATION</b>	<b>ASSEMBLY / INSTALLATION</b>	<b>SAFETY / SPECIFICATIONS</b>	<b>GETTING STARTED</b>
-----------------------------	------------------------	------------------	--------------------------------	--------------------------------	------------------------

**REPAIR PARTS LIST FOR 9681115 6" X 9" BELT/DISC SANDER (CONTINUED)**

Ref. No.	Description	Part No.	Qty.	Ref. No.	Description	Part No.	Qty.
57	Locking nut	9642877.01	2	83	Slide bar	9642895.01	1
58	Flat washer M8	*	5	84	Miter gauge pointer	9642896.01	1
59	Rubber foot	9642878.01	2	85	Disc table left support	9642897.01	1
60	Dust port cover	9642879.01	1	86	Left scale	9642898.01	1
61	Philips screw + spring washer M5x16	*	3	87	Right scale	9642899.01	1
62	Tension spring	9621426.01	1	88	Disc table right support	9642900.01	1
63	Bushing	9642880.01	2	89	Spring washer M6	*	4
64	Driven drum support	9642881.01	1	90	Handle	9642901.01	2
65	Nut M5	*	1	91	Inner hex head screw M5X56	9642902.01	1
66	Belt tracking knob M8	9642882.01	1	92	Switch guard	9642903.01	1
67	Rubber washer	9642883.01	1	93	Star-head screw M3x10	*	2
68	Adjustment rod	9642884.01	1	94	Switch with key	9642904.01	1
69	Adjustment spring	9642885.01	1	95	Disc guard	9642905.01	1
70	Spring II	9642886.01	1	96	Big washer M6	*	1
71	Belt tension handle	9621428.01	1	97	Sanding disc, 9" PSA 80 Grit	9616731.00	1
72	Powder metal bushing	9642887.01	1	98	Aluminum disc plate	9621446.01	1
73	Position ring for driven shaft	9642888.01	2	99	Disc cover	9630671.01	1
74	Inner hex position screw M5X6	9642889.01	2	100	Adapter	9642906.01	1
75	Spring washer for shaft M12	*	2	101	Pointer	9642907.01	2
76	Driven shaft	9642890.01	1	102	Hex wrench S=4	NA	1
77	Driven drum	9642891.01	1	103	Hex wrench	NA	1
78	Miter gauge knob	9642892.01	2	104	Clip	9642908.01	1
79	Miter gauge label	9642893.01	1	105	Hex nut M5	*	2
80	Miter gauge	9642894.01	1	106	Philips screw M5x10	*	2
81	Philips screw + spring washer + flat washer M5x8	*	1	107	Hex nut M6	*	4
82	Philips screw M8x25	*	2	108	Philips screw + outer tooth washer + flat washer M5x16	*	1

(Δ) Not shown.  
 (\*) Standard hardware item, available locally.  
 (N/A) Not available as replacement part.



**TROUBLESHOOTING GUIDE**

Symptom	Possible Cause(s)	Corrective Action
Motor will not start	<ol style="list-style-type: none"> <li>1. Blown line fuse or tripped circuit breaker</li> <li>2. Low line voltage</li> <li>3. Defective switch</li> <li>4. Defective, blown capacitor</li> </ol>	<ol style="list-style-type: none"> <li>1. If fuse is blown, replace with fuse of proper size. If breaker tripped, reset it</li> <li>2. Check power supply for voltage and correct as needed</li> <li>3. Replace switch</li> <li>4. Replace capacitor</li> </ol>
Motor will not start; fuses blown or circuit breakers tripped	<ol style="list-style-type: none"> <li>1. Overloading due to binding</li> <li>2. Defective plug</li> <li>3. Defective cord</li> <li>4. Defective switch</li> <li>5. Faulty internal wiring</li> </ol>	<ol style="list-style-type: none"> <li>1. Clean around wheels and shaft and/or replace bearings</li> <li>2. Replace plug</li> <li>3. Replace cord</li> <li>4. Replace switch</li> <li>5. Contact authorized NORSE Service Center</li> </ol>
Motor fails to develop full power (power output of motor decreases rapidly with decrease in voltage at motor terminals)	<ol style="list-style-type: none"> <li>1. Power line overloaded with lights, appliances and other motors</li> <li>2. Undersized wires or circuits too long</li> <li>3. General overloading of power company's facilities</li> </ol>	<ol style="list-style-type: none"> <li>1. Reduce load on power line</li> <li>2. Increase wire sizes, or reduce length of wiring</li> <li>3. Request a voltage check from power company</li> </ol>
Motor overheats	Motor overloaded	Reduce load on motor
Motor stalls (resulting in blown fuses or tripped circuit breakers)	<ol style="list-style-type: none"> <li>1. Short circuit in motor or loose connections</li> <li>2. Low voltage</li> <li>3. Incorrect fuses or circuit breakers in power line</li> <li>4. Motor overloaded</li> </ol>	<ol style="list-style-type: none"> <li>1. Inspect connections in motor for loose or shorted terminals or worn insulation on lead wires</li> <li>2. Correct the low line voltage conditions</li> <li>3. Install correct fuses or circuit breakers</li> <li>4. Reduce load on motor</li> </ol>
Machine slows down while operating	<ol style="list-style-type: none"> <li>1. Applying too much pressure to workpiece</li> <li>2. V-belt slipping</li> </ol>	<ol style="list-style-type: none"> <li>1. Ease up on pressure</li> <li>2. Increase V-belt tension</li> </ol>
Abrasive belt runs off top wheel	Not tracking properly	See operation section "Adjusting Sanding Belt Tracking", page 8.



## NORSE Warranty

NORSE by C.H. Hanson warrants their products to be free of defects in material or workmanship. This warranty does not cover defects due directly or indirectly to misuse, abuse, normal wear and tear, failure to properly maintain the product, heated, ground or otherwise altered, or used for a purpose other than that for which it was intended.

The warranty does not cover expendable and/or wear part (i.e. v-belts, screws, abrasives, jaws), damage to tools arising from alteration, abuse or use other than their intended purpose, packing and freight. The duration of this warranty is expressly limited to the terms noted below beginning from the date of delivery to the original user.

The NORSE branded items carry the following warranties on parts:

All NORSE branded Tools and Accessories 1 YEAR

The obligation of NORSE by C.H. Hanson is limited solely to the repair or replacement, at our option, at its factory or authorized repair agent of any part that should prove inoperable. Purchaser must lubricate and maintain the product under normal operating conditions at all times. Prior to operation become familiar with product and the included materials, i.e. warnings, cautions and manuals.

### **Failure to follow these instructions will void the warranty.**

This warranty is the purchaser's exclusive remedy against C. H. Hanson for any inoperable parts in its product. Under no circumstances is C. H. Hanson liable for any direct, indirect, incidental, special or consequential damages including loss of profits in any way related to the use or inability to use our products. This warranty gives you specific legal rights which may vary from state to state.

### **SERVICE & REPAIR**

1. If a NORSE product requires a repair or warranty service **DO NOT** return the product to the place of purchase.
2. All warranty related work must be evaluated and approved by NORSE.
3. Prior to returning any item the user must obtain factory approval and a valid RGA number.
4. For instructions and RGA number call toll free (800) 827-3398.



**NORSE - a C.H. Hanson brand**  
**2000 N. Aurora Rd., Naperville, IL 60563 U.S.A.**  
**or call: 1-800-827-3398**

