

DLX PLUS PRECISION COMPRESSION DAMPENED SHOOTING REST



For parts or technical support contact:

Hyskore® Power Aisle, Inc.
P.O. Box 983 • Middleburgh, NY, 11746
Phone: 631.673.5975 • Fax: 631.673.5976

visit us at www.hyskore.com

DLX PLUS PRECISION COMPRESSION DAMPENED SHOOTING REST



Always Use Appropriate Eye & Ear Protection When Using This Device!

This excellent rifle rest is designed for the serious shooter or hand loader. It will accommodate everything from a .270 WIN to a .375 H&H without damage to your weapon or to your shoulder. For light recoiling guns such as .22-250, .223 etc., it is necessary to purchase the optional spring pack (See Replacement Parts). All you need to do is pay attention to the instructions and observe all standard safety procedures. We have upgraded the 30088 by adding a butt strap set so that you can comfortably shoot with your shoulder placed against the gun.

Before using this product, it is imperative that you read the Instructions. Improper use could result in injury or damage to your weapon and/or the rest.

It is important to use a rock-solid bench. The DLX Precision Shooting Rest is capable of impressive repeatability. However, if your bench moves, your group will open. Go to the Hyskore® website and view both the demo and FAQ "Things you should know..." videos.

That being said, follow the simple assembly instructions and enjoy this fine shooting accessory.

In the course of shipping and packing, parts may end up missing or damaged- call us at 631.673.5975. 8:30 a.m. - 5:00 p.m. Eastern Time. We will promptly send replacements.

Introduction

READ THIS ENTIRE MANUAL BEFORE USING THE REST!

The purpose of the DLX Plus Precision Shooting Rest is to allow the shooter to fire the weapon without having to contend with recoil. By calibrating the weapon and/or ammunition in this manner the shooter is able to obtain a clear picture of weapon accuracy. We have upgraded the DLX to include a strap and bracket so that you can shoot directly off the shoulder.

WARNING !!

- The DLX Plus Precision Shooting Rest will accommodate most factory rifle/ammunition combinations from .270 WIN thru .375 H&H. Always calculate your recoil and NEVER exceed the Damper's upper limit.
- Vibration and motion caused by shooting may cause knobs, straps and adjustments to loosen. Check them after every 3rd shot. Pay special attention to the fittings that hold the gas spring in place.
- Every 3rd Shot make sure the 2 velcro straps are properly secured.

READ THIS CAREFULLY

The DLX Plus Precision Shooting Rest is designed and constructed to operate consistently and safely within certain limits, i.e., do not use gun/ammunition combinations that will exceed the recoil range for the compression damper. The following chart is a general guideline for recoil expectations. If you exceed the maximum recoil you can expect several very bad things to happen as the travel of the damper may be exhausted and the gun carrier may "bottom-out".

First: Expect damage to the gun stock as the inertia of the barrel/action will now be absorbed by those components.

Second: For the same reason you can expect the action/and barrel to separate from the bedding.

Third: You may damage the structural components of the rest. Always calculate the maximum recoil for your gun and Ammunition combination and NEVER exceed the Damper's upper limit. Conversely, using too much compression for the gun/ammunition combination can result in similar consequences. To use guns with light recoil, like a .223/5.56, you should purchase the #30028 spring pack (see replacement parts).

If you're not impressed with damage to your weapon and your rest, over loading the device by using a light gun and/or too potent a loading for the damper has the potential to result in serious injury. Use common sense and observe, all firearms safety procedures. Never use this rest to fire any weapon that is not in "as new" condition or certified safe by a competent gunsmith.

Never exceed the Gun Manufacturer's maximum recommended loading for any ammunition.

Repeat: if you do something dumb, bad things can happen. The chart is only a general guideline. For more detailed recoil data (as of this writing) there are several good websites that you can reference:

- <https://shooterscalculator.com/recoil-calculator.php>
- <https://bisonballistics.com/calculators/recoil>
- <https://www.omnicalculator.com/physics/recoil-energy>
- http://huntamerica.com/recoil_calculator/
- <https://jbmballistics.com/cgi-bin/jbmrecoil-5.1.cgi>

or go to our website (www.hyskore.com) then click on a link for a recoil calculator.

REPLACEMENT PARTS

These are replacement parts for purchase. Pictures do not represent contents of set.



Parts List:

| | | |
|------------|---|---------|
| 30088 - 1 | Compression Damper | \$37.50 |
| 30088 - 2 | Bench Grip Arm | \$27.50 |
| 30105 - 9 | Butt Strap..... | \$17.50 |
| 30088 - 4 | "V" Notch Support..... | \$22.50 |
| 30088 - 5 | M10 Knobs for "V" Notch Support (2 Knobs) | \$ 7.50 |
| 30088 - 6 | Magnetic Backed Spirit Level | \$ 7.50 |
| 30089 - 1 | Butt Retention Bracket | \$22.50 |
| 30089 - 2 | Foam Pad (For Inside Of Butt Bracket) | \$ 7.50 |
| 30088 - 11 | Velcro Web Strap Set (2 Straps) | \$15.00 |
| 30088 - 12 | Foam Pads (must be glued in place)..... | \$ 7.50 |
| 30028 | Spring Pack (Includes S&H) | \$17.50 |
| 30018 - 10 | Butt Socket | \$17.50 |
| 30018 - 13 | Foam Pads (For Inside Butt Socket)..... | \$ 7.50 |

Visit our website for more information or to check our other great shooting accessories: www.hyskore.com

Send Check or Money Order with Phone Number to:

Hyskore® / Power Aisle, Inc.

P.O. Box 983

Middleburgh, NY 12122

NYS Resident add 8.75% Sales Tax (or prevailing rate)

** \$17.50 Shipping & Handling to Lower 48 States**

** \$29.50 Shipping & Handling to Alaska, Hawaii, Puerto Rico**

WARRANTY AND DISCLAIMERS

HYSKORE/Power Aisle, Inc. guarantees that its products are free from defects in material and workmanship for a period of 90 days from the original date of purchase. This Warranty applies to non-commercial use only. Commercial use voids this warranty. In the event of any defects in material or workmanship, HYSKORE/Power Aisle, Inc.'s sole liability therefore shall be the replacement of any such product(s) and/or components that are defective in material or workmanship. The replacement of any such product(s) and/or components shall be HYSKORE/Power Aisle, Inc.'s sole responsibility. This warranty specifically excludes any and all consequential or accidental damages. No other warranties or liabilities whatsoever are either expressed or implied. If any such warranties shall be imposed by law, notwithstanding this provision, then such warranties shall be the responsibility of HYSKORE/Power Aisle, Inc.'s immediate buyer. There shall be no warranties of merchantability, use of trade, or fitness for a particular purpose. Alteration of any product, misuse, or exceeding any stated product limitations voids this warranty. All returns, adjustments, etc. are the responsibility of the retailer/dealer that sold the product. HYSKORE/Power Aisle, Inc. handles return issues through it's dealers. It should be obvious when using some of these products that approved protective safety gear, including, but not limited to, eye and ear protection, should be utilized. Using the appropriate safety gear is the sole responsibility of the person(s) using the product. It should also be obvious that certain products such as silica gel, etc. must not be consumed, inhaled or taken internally. The user takes full responsibility for inappropriate or incorrect use of these items. In the event an inadvertent event takes place, Material Safety Data Sheets (MSDS) are available on the HYSKORE website. www.hyskore.com. We do not sell guns, scopes, ammunition, cleaning accessories, etc. These accessories are used in many of our product pictures, as props to illustrate how the products are used. As such, they are not included with any product. All photographs, drawings, copy, instructions, etc. are the exclusive property of HYSKORE/Power Aisle, Inc. All downloadable files are intended for the use of the end user of HYSKORE/Power Aisle, Inc.'s products and cannot be reproduced without the express written permission of HYSKORE/Power Aisle, Inc. ©2023

5



Before cutting the notch examine your rest. Different models require different size notch(es).

Notch the front so that the edge of the notch is flush with the surface of the plywood base. This can be done either before or after it is fixed in place.

6



Use 2 - 5/16" x 3/4" sheet metal screws to anchor the left & right sides of the rest. You may find it necessary to stack several flat washers between the flange on the rest and the plywood

7

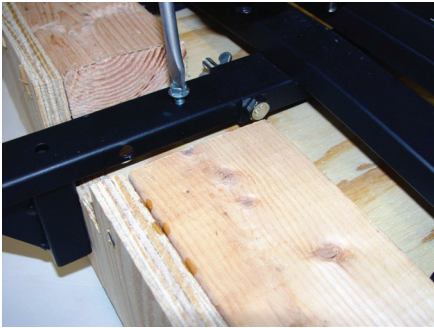

Use 1 - 5/16" x 1 1/2" (or 2") sheet metal screw to anchor the bench grip arm.

8

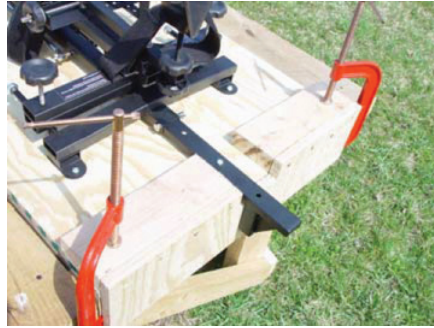

Use 2 or 4 - "C" clamps to anchor the completed set-up to the bench.

APPROXIMATE RECOIL IN FT. LBS.

| Cartridge | Bullet Weight | Muzzle Velocity | 7.0 LBS Gun | 8.0 LBS Gun | 9.0 LBS Gun |
|---------------|---------------|-----------------|-------------|-------------|-------------|
| 12GA | 525 (Slug) | 1522 | 46 | 38 | 34 |
| 30 - 06 SPFLD | 150 | 2850 | 23 | 20 | 18 |
| 30 - 06 SPFLD | 200 | 2600 | 29 | 25 | 22 |
| 308 Win | 150 | 2750 | 18 | 16 | 14 |
| 308 Win | 200 | 2350 | 20 | 18 | 16 |
| 300 Win Mag | 150 | 3210 | 33 | 29 | 26 |
| 300 Win Mag | 200 | 2850 | 38 | 33 | 29 |
| 300 Rem UM | 150 | 3670 | 45 | 40 | 35 |
| 300 Rem UM | 200 | 3130 | 52* | 45 | 40 |
| 300 WBY Mag | 150 | 3424 | 39 | 34 | 30 |
| 300 WBY Mag | 200 | 3014 | 45 | 39 | 35 |
| 8mm Mauser | 150 | 2695 | 18 | 16 | 14 |
| 8mm Mauser | 200 | 2434 | 24 | 21 | 18 |
| 338 Win Mag | 160 | 3098 | 37 | 33 | 29 |
| 338 Win Mag | 270 | 2930 | 39 | 34 | 30 |
| 375 H & H | 300 | 2700 | 55* | 48 | 42 |

The DLX Plus Precision Shooting Rest is primarily designed for center fire rifles. If you use it for a rim fire weapon, you must remove the compression damper to avoid damage to the weapon.

See section on How to set up for Rimfire Rifles

The DLX Plus Precision Shooting Rest will successfully accommodate a much wider range of cartridges than listed on the chart. But only if (and we repeat - ONLY IF) you have performed the recoil calculations and determined that the recoil is within the range of the damper. Not to be repetitive but, if you exceed the recommended limits for the damper, bad things can happen, not only can you damage the rest and/or your weapon but the end result could be personal injury.

The recoil that you feel is a function of the action-reaction created as the bullet moves forward in the barrel and, shortly thereafter, gas exiting the muzzle (Rocket Effect). Therefore, the quantity of propellant in addition to gun weight, bullet weight and muzzle velocity is an important factor in determining recoil. Make certain that this is part of your calculation. Calculate your recoil carefully and

DO NOT EXCEED THE LIMITS OF THE COMPRESSION DAMPER!

For gun/ammunition combinations above 20-30 ft. lbs. use the Hyskore 30185 Black Gun Machine Rest

Before proceeding make both a visual and mechanical examination to make sure your weapon is unloaded.

Instructions:

1. Mount the "V" notch front gun support as **Fig. 9**.
2. Mount the butt socket with 3 bolts & nuts as in **Figure 1-A**. Do not over-tighten. The included butt strap bracket installs the same way and can be used in place of the steel butt socket.
3. To adjust any lateral movement at the rear of the rest use screws **C** in **Figure 1**. Lightly hand tighten until the screw stops then back off ¼ turn. Lock in place with the jam nut and cycle the rest to make sure there is no binding.
4. Place the rest on a solid, level, flat surface. Pointing down range!

Securely anchoring the rest to a solid (non moving) bench increases repeatability.

5. Extend and invert the bench grip, fix it to the rest with the supplied wing nut and bolt. **Figure 2 A**
6. The arm of the bench grip and the cross support are fitted with 1/4" holes. You can use them to securely anchor the rest. See **Figure 2 A**

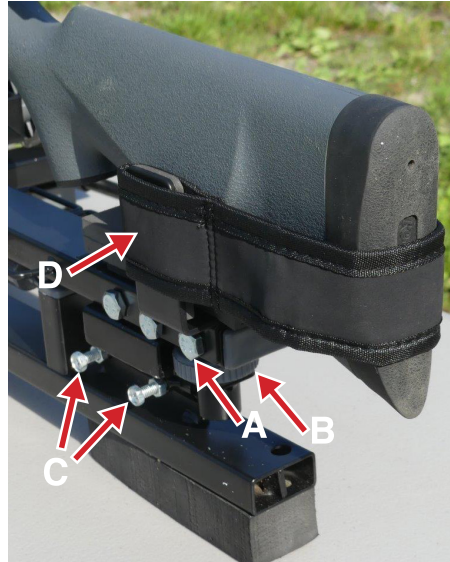

Figure #1

NOTE: Before you anchor the rest check your elevation. If it is too high, it may be necessary to elevate the rear end of the rest with a wood block.

7. Set the gun in place. Securely wedge the butt into the socket. Use foam pads or a clean soft cloth or shop towel to insure a snug fit. See **Pg. 10**. **If you are using the butt strap, this is not necessary.**
8. Set the elevation of the fore end support. *Do this before you secure the weapon.*
9. Using the rear Velcro strap snugly fasten the gun into place. **Figure 2-D**
10. Secure the forward strap allowing for the barrel to rise no more than ¼" to allow the barrel to float properly.
11. Use the fine elevation **1B** and windage knobs **2E** to zero in. Use the left and right knobs to adjust cant. **Figure 2F** To adjust fine elevation use nut **B** in **Figure 1**. One full turn will elevate the rear of the gun 1.0 mm. You are now ready to fire.
12. After the shot it may be necessary to push forward on the back of the rest to return to 100% battery.

Important Safety Recommendations:

You will have a tendency to look through the sight when firing - DO NOT DO THIS IF YOU ARE USING THE STEEL BUTT SOCKET!

1. *Do not put your eye, face or hand (or any other body part) behind the sight, scope or anywhere else near the gun. A 30-06 will generate 1.5-2.00 of very rapid rearward travel. If you are in the way you will get hurt.*
2. Always wear approved eye and ear protection.
3. Velcro does not last forever. When it shows signs of wear or degradation in grip, replace it.
4. **Do not drop!** All parts are factory aligned then welded into place. If you bend something it may not be repairable or replaceable. Using the rest in damaged condition could result in injury.
5. *Load one round at a time.* This way the gun will have uniform weight every time it is fired.
6. Do not use high-capacity magazines as there may not be sufficient clearance under the gun.

Maintenance:

1. All the non-contact metal parts are powder coated. This is a durable finish. However, if you don't dry it off after it gets wet, eventually it will rust.
2. Lubricate the windage, fine elevation and cant adjustments. Use Acid Free Machine Oil· Sew Machine Oil works well. Do not use WD-40.

1

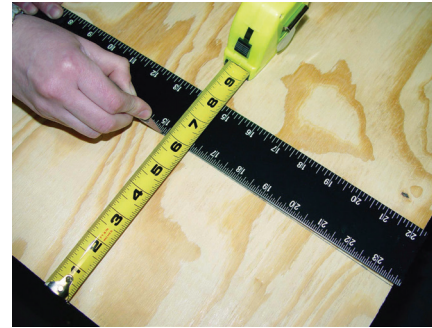

Using a 24" x 48" x ¾" piece of plywood cut a 6" x 24" section of the plywood for the front edge brace.

2



Cut 2 - 10 pieces of 2" x 4".
Glue and screw them to the plywood base.

3



Use 2" screws to secure the 2" x 4" x 10" blocks from the underside.

4

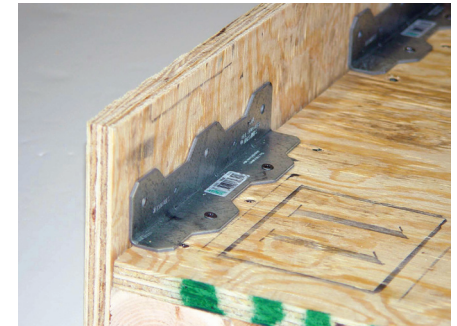

Glue & screw (with 2 screws) the 6" x 24" piece of plywood across the front as shown.
Use 2" x 6" (or 8") stair angles for reinforcement.
Secure with screws.

Hyskore®
Suggestions For Building A Shooting Platform Bench
For the 30275 Dual Damper Machine Rest, 30088 DLX, 30089 DLX Plus Precision
DLX Rifle Rest and the 30185 Black Gun® Machine Rest



All of the above captioned rifle rests must be secured to a bench. When there is a concrete bench or a range that doesn't allow shooters to screw anything to their benches it is necessary to mount your rest to a platform that can be fixed to the bench using "C" Clamps.

30013 (discontinued) is illustrated. Different models may require a larger notch.

Suggested Bill of Materials:
For Constructing a Bench Platform

These components can be purchased at any big box home improvement retailer.

| Qty. | Description |
|----------|--|
| 1 - | 24" x 48" x 3/4" Plywood |
| 2 - | 2" x 4" x 8" wood block |
| 2 - | 6" or 8" stair angles (These are heavy duty 90° angle braces. At Lowes or Home Depot they can be found in the lumber area with the joist hangers.) |
| 1 - | Wood Glue (The exterior type is the best) |
| 2 - | 5/16" x 3/4" Sheet Metal Screws |
| 1 - | 5/16" x 1 1/2" (or 2) Sheet Metal Screw |
| 16-20 - | 2" Drywall Screws |
| 2 or 4 - | "C" Clamps (size will depend on the thickness of the bench) |

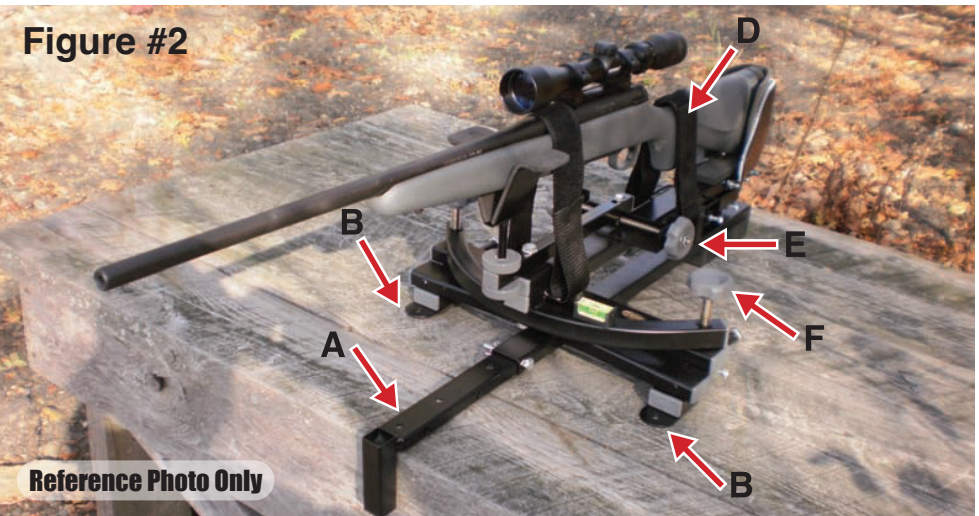

Set Up For A Light Recoil Centerfire Rifle
(You Will Need To Purchase The Optional Spring Pack)

(.220 swift ~ .223/5.56 ~ .22 - 250 etc.)

1. Remove Damper - Back off the hex nuts that hold the damper in place and remove the damper. (Fig. 1) The upper carrier should now move easily front to rear as the rest must cycle freely. Due to the fact that it is not possible to supply a damper that will accommodate all guns, for light recoiling guns it is necessary to purchase the spring pack. If not available from your retailer, contact Hyskore® directly at 631-673-5975 9 a.m. - 5 p.m. M-F Eastern time.

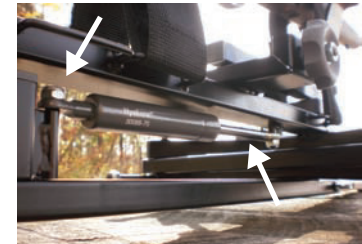

2. Install Springs - Remove the 2 insert lock nuts (A) slide the spring over the guide (B) (Fig. 2) Replace the lock nuts. For a 10 lb AR 15 cal. . 223/5.56 the blue springs work well. For guns with less recoil try the yellow or red springs. As the springs do not have the high compression of the damper, it may be necessary to push the gun/carrier forward to battery after each shot.

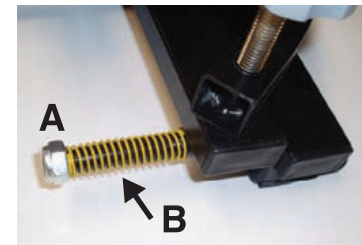

3. When you go to shoot a gun with heavier recoil, replace the damper and remove the springs. (The shaft end of the damper faces forward). It may be necessary to use the fine elevation to move the gun carrier upward to gain clearance to get the damper over the stud and fit the nut in place. (Fig. 3)



To Shoot A Rimfire Gun or an Air Gun that uses C02 or a Compressed Air Cylinder

1. Remove Damper - Back off the hex nuts that hold the damper in place and remove the damper. The upper carrier should now move easily front to rear. (See Below)

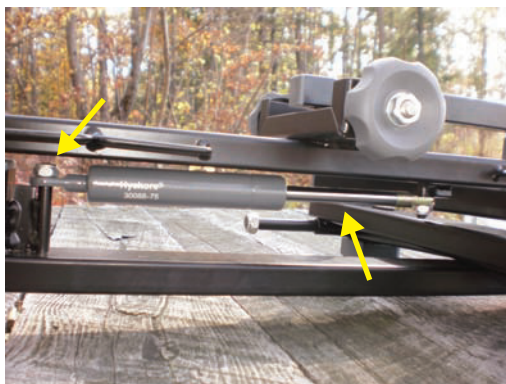

2. Make sure that the rest without the damper cycles freely front to back.

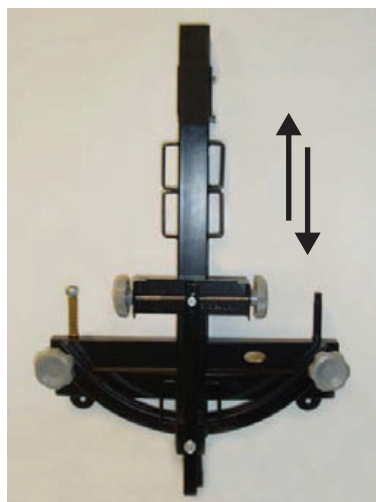

3. Before each shot push the carrier and gun to the most forward position. As there is no damper or spring pressure to move things back to battery this must be done manually. If you fail to do this you will lose group consistency.

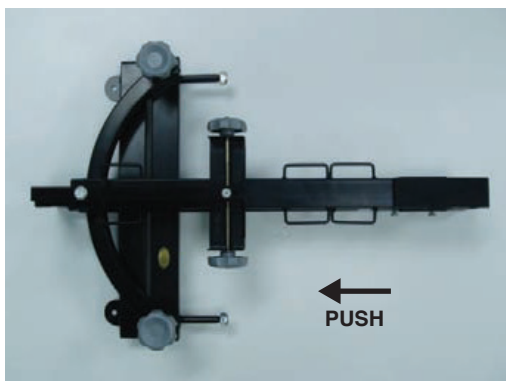

Do your calculations with 2 or 3 different powder weights and you will see that the recoil energy (RE) only varies slightly. The 64.4 number is a constant and the 7000 number is the number of grains in one pound.

Repeat: if you do something dumb, bad things can happen. The chart is only a general guideline.

For more detailed recoil data (as of this writing) there are several good websites that you can reference:

1. <https://shooterscalculator.com/recoil-calculator.php>
2. <https://bisonballistics.com/calculators/recoil>
3. <https://www.omnicalculator.com/physics/recoil-energy>
4. http://huntamerica.com/recoil_calculator/
5. <https://jbmballistics.com/cgi-bin/jbmrecoil-5.1.cgi>

The recoil that you feel is a function of the action-reaction created as the bullet moves forward in the barrel and, shortly thereafter, gas exiting the muzzle (Rocket Effect). Therefore, the quantity of propellant in addition to gun weight, bullet weight and muzzle velocity is an important factor in determining recoil. Make certain that this is part of your calculation. Calculate your recoil carefully and **DO NOT EXCEED THE LIMITS OF THE COMPRESSION DAMPER/SPRING COMBINATION!**

PARALLAX

When attempting to achieve the highest degree of repeatability i.e. smallest group size with any HYSKORE® shooting rest, it is important to have a clear understanding of parallax. Even experienced, good shots can improve their group size by up to 30% by paying close attention to parallax. Parallax is the difference in apparent position of an object viewed along two different lines of sight. To experience parallax extend one of your arms, hold an index finger up, close your left eye, and align the index finger with an object on the distant wall. Now close your right eye and open your left. The object has appeared to have moved. What has actually happened is that you are now viewing the object along a different line of sight. This is exactly what happens inside a rifle scope. We have prepared three diagrams to show you the various conditions that may develop in sighting with a scope.

- A. This is a parallax free focusing arrangement. The image of the target is focused on the reticle.
(The reticle is the optical element inside the scope on which the cross-hairs are inscribed.)
- B. The image focuses in front of the reticle and in this case you would experience parallax.
- C. The image focuses behind the reticle and also in this instance you could experience parallax.

The correction in diagrams B and C is to adjust the objective lens of the scope so the image focuses on the reticle. On better scopes there is usually an adjustment on the objective bell (this is the end of the scope facing the target) with yardage markings. By turning this you can approximate the correct adjustment. However, since parallax is magnification and range variable, it is a good idea to clamp the rifle in a solid vise on the bench top (The HYSKORE® #30022 Parallax Cleaning and Sighting Vise is perfect for this.) Look at the target through the scope and shift your eye left to right. If the cross-hairs remain dead center on the target you are parallax free. If not, you need to do additional adjustments. Inexpensive and low magnification scopes are usually parallax free at a specific range, and do not have parallax adjustments.

Keeping the pupil of your eye concentric with the optical axis of the scope is critical to eliminating parallax. If you can keep your eye positioned on the axis every time you will experience parallax free shooting. Of course, this is almost impossible to do and repeat shot after shot.

Moving your eye even a few thousandths of an inch off dead center, when parallax is present, will influence your visual alignment and cause you to change your point of aim, resulting in expanding your group. Therefore, you must make the appropriate adjustments at the designated range to remove parallax. Unfortunately, most scope manufacturers assume that all shooters have a working knowledge of parallax. As a result, the instructions they provide give little or incomplete details regarding this optic condition.

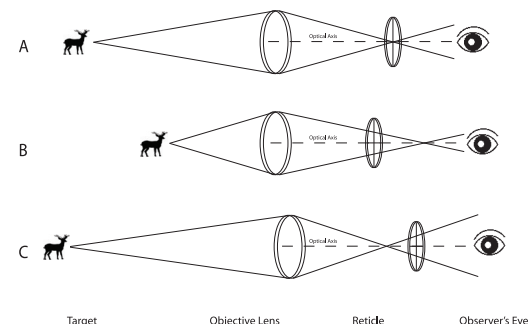

CALCULATING RECOIL

There are two ways to do this.

- The easy way - go to one of the websites listed in this pamphlet or go to one of the links listed on our website: www.hyskore.com
- If you like playing with numbers, use the following formula. While Isaac Newton or Albert Einstein might take us to task for being off by 2 or 3 %, this will get you into the ballpark. We have divided the process into 2 steps. First, calculate the recoil velocity then use this information to calculate the recoil energy in ft/lbs.

Legend:

- PW - Weight of powder charge
- BW - Weight of bullet (grains)
- MV - Muzzle Velocity
- GW - Weight of loaded gun/w scope
- RV - Recoil Velocity
- RE - Recoil Energy

$$1. RV = \frac{[(1.75 \times PW) + BW] \times MV}{7,000 \times GW}$$

Run the calculation like this:

- Multiply the weight of the powder charge PW x 1.75
- Add the bullet weight (BW) to this number (result from A)
- Multiply this number (result from B) by the bullet velocity (MV) - Hold this number aside
- Multiply the weight of the gun (GW) x 7000
- Take the calculation from D (GW x 7000) and divide it into the number you held aside in C (above) - This is the velocity of the recoil.

$$2. RE = \frac{RV^2 \times GW}{64.4}$$

Run the calculation like this:

- Square the recoil velocity and multiply it by the weight of the gun
- Divide this number (result from F) by 64.4. This is the recoil energy in ft./lbs.

Example: Actual data for .308 Winchester model 70 with 24" barrel & scope.

- PW = 40 Grains
- BW = 180 Grain (sierra match king)
- BV = 2,500 Fps
- GW = 8.2 lbs.

$$RV = \frac{[(1.75 \times 40) + 180] \times 2,500}{7,000 \times 8.2} = \frac{625,000}{57,400} = 10.89 \text{ fps}$$

$$RE = \frac{10.89 \times 10.89 \times 8.2}{64.4} = \frac{972}{64.4} = 15.10 \text{ ft./lbs.}$$

The Recoil Velocity (RV) is 10.89 fps

The Recoil Energy (RE) is 15.10 ft/lbs

A few pointers

- The weight of the gun (GW) should always be in pounds, eg. 7.3, 8.2, etc.
- The weight of the powder charge has a very small influence on the recoil velocity (RV) or recoil energy (RE). If you do not know the exact number, use the following guidelines:

| | |
|------------------------|--------------|
| .219 - .223 | - 25 grains |
| .22 - 25 - .257 | - 38 grains |
| .264 - .28 - 55 grains | |
| .308 - 30'06 | - 45 grains |
| .300 & 7mm mag | - 62 grains |
| .338 | - 70 grains |
| .375 | - 85 grains |
| .416 - .458 | - 110 grains |

Adjusting A Rest That Sticks

To test if the gun carrier moves freely, set the tail end of the rest on the floor. Hold the rest vertically and push against the gun carrier. It should move about 2" - 3" against the damper and then return to the forward position after you remove pressure. If it doesn't move freely, the cause may be corrosion, contamination, and/or excess finish applied at the factory. To correct the problem, remove the damper (see Remove Damper) and the large insert lock nuts and slide the gun carrier off the base -reverse the process to reassemble.

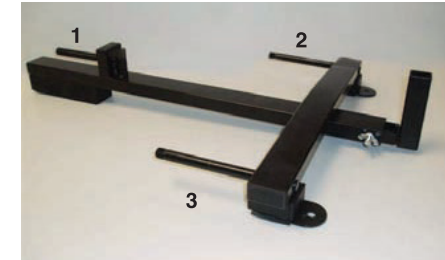
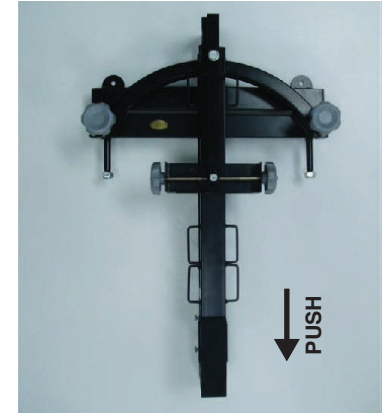

The 3 guide rods #1, #2, and #3 must be cleaned. Use sandpaper (plumber's emery cloth works best) to polish all 3 guide rods.



Lubricate with acid free machine oil - (Singer sewing machine oil works well) or a dry lubricant.



Spring Air Guns

To use with a spring powered air gun we need to do things a little different. Spring Powered air guns are those that either require a lever for cocking or have a break action. These guns recoil forward NOT rearward. Set up the rest the same as if you were going to fire a rimfire rifle. However, you must pull the gun and carrier all the way to the rear, until it stops, before each shot. If you fail to do this, it will have a negative impact on group consistency.

A Few Pointers

1. The “V” shaped foam wedge is for use with guns that have wide forends. For guns with thin or standard forends, do not use the wedge as it will allow side play between the gun and the support. This will have a negative impact on consistency and group size.
2. The knobs that hold the “V” notch forward support in place can loosen. This will cause groups to be inconsistent. Check the knobs frequently. You can also use tooth lock washers to hold them in place.
3. Even with the rest tightly secured to the bench, it is possible for the tail end to shift a little. This may have an impact on consistency. The solution is to drill a $\frac{3}{16}$ " or $\frac{1}{4}$ " hole through the pad and steel tube at the rear of the rest and screw it to the bench at this point. Note that there is a support in the middle of the tube therefore, it is necessary to drill the hole slightly to one side. On newer production, the hole in the steel tube has already been drilled.

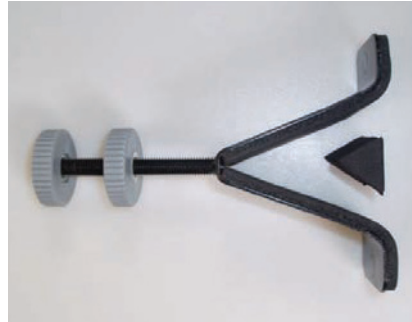

- G. Parallax is the apparent shift of the target relative to the reticle due to the horizontal movement of the observer. Scopes with parallax adjustments must be correctly adjusted. Scopes without a parallax adjustment are generally range specific for parallax free sighting. If you have made the adjustments to eliminate parallax you are good to go. If not, it is important to make sure that the longitudinal optical axis of the scope that runs through the center of the cross-hairs is directly aligned with the pupil of your eye. If you have an inconsistent cheek weld to your stock or fail in any other way to address parallax your groups will suffer from horizontal dispersion, i.e.:open up left to right. This will happen because your view of the target in the horizontal plane will vary with each shot.
- H. Barrel temperature plays a major role in maintaining group size. As a barrel heats up torsional stress will cause the barrel to twist. Bench rest shooters wait several minutes between each shot to keep the barrel from overheating. If you fire 10 or 12 shots in rapid succession from a sporter weight barrel your groups will expand.
- I. Other factors, which we will not explore here include: Free floating barrels, bedding, barrel harmonics, etc. - Not to mention the shooter!

RIM FIRE ACCURACY

(Some of this applies to center fire rifles also.)

Accuracy in a rim fire rifle is to a large degree more dependent upon the ammunition as opposed to the equipment. Center fire ammunition can be loaded and/or reloaded to precise and consistent specifications. Rim fire ammunition can only be loaded at the factory level. Since rim fire ammunition is not re-loadable, it's necessary to use whatever is commercially available. Factors affecting rim fire accuracy are:

- A. As with a center fire cartridge there is a SAAMI specification (ANSI/SAAMI Z 299.1-1992) and variance for the dimensional aspects of rim fire ammunition that allows up to -.004 under the standard diameter for .22 long rifle match or sporting ammunition. Consequently, manufacturers make ammunition within the entire range of this variance. As a direct result a gun that is expected to perform reliably must be able to accept the full range of available ammunition. What this has led to are guns that are match chambered which are invariably bolt action. (The chambers in these guns have a tight precise cartridge fit and the guns perform best with match grade ammunition that is made to close tolerance), and then we have most other guns that have sporting chambers, many of which are auto loaders. The chambers in these guns must be made large enough so that the gun will cycle correctly with any off the shelf brand of ammunition which could be manufactured to any size within the allowable range of tolerance. i.e., this means the cartridge may fit loosely in the chamber. Due to gravity the cartridge settles into the lowest portion of the chamber. The result is that the center axis of the chamber, and hence the center axis of the barrel is not aligned with the center axis of the bullet. This means that the bullet will engage the rifling off center and will travel down the barrel and exit the muzzle at an angle resulting in a loss of stability and accuracy.
 - B. Concentricity – If the long axis of the bullet is not concentric with the long axis of the case it will also not be concentric with the long axis of the bore, as above the bullet will travel down the barrel and exit the muzzle at an angle with similar results. As little as .002"–.003" off center will cause a noticeable enlargement of the grouping.
 - C. Head Spacing is the distance the bullet must move from the casing until it engages the rifling. In a rim fire this is controlled by thickness of the rim. According to SAAMI standard rim thicknesses may vary from as little as .036" to as much as .043". A gun may perform much better with one rim thickness as opposed to others. It is therefore important to test your gun with a wide range of ammunition. Typically in a box of inexpensive ammunition you will find a considerable variance in rim thicknesses. This will usually result in expanding the group size; consistency of rim thickness will result in smaller, consistent group sizes. Both concentricity and rim thickness can be measured by using the HYSKORE® #30075 Ammo Analyzer.
 - D. If the group spread is more vertical than horizontal it is usually the fault of the ammunition. At a known distance, a faster bullet reaches the target quicker and drops less, i.e. gravity has less time to act. As you may appreciate, the small quantities of primer and propellant used in a rim fire cartridge must be precisely and accurately measured in order to produce consistent velocity. Only a small variance in absolute terms translates to a significant percentage variation and by extension, variation in velocity. Maintaining this type of consistency across large production runs is incompatible with maintaining low cost. Primer compound has an explosive force in the magnitude of 25 to 50 times that of the propellant. As little as 1/10 grain (1/70,000 lb.) deviation will cause a velocity differential. With these thoughts in mind, the culprit in groups that open top to bottom is almost always inconsistent velocity. The faster bullets strike higher and the slower ones lower.
 - E. Scope Problems -See “F” and “G” under Center Fire.
- The aforementioned issues represent a brief synopsis of various conditions that may affect accuracy. There are numerous in depth studies that can provide detailed analysis of each situation. We are not experts and do not intend to be. Our comments and suggestions are the result of studying and compiling data from a wide range of sources. Furthermore, we have only touched on the more significant factors that affect accuracy. If you elect to make adjustments to your gun/ammunition combination to increase accuracy, we suggest that you address each issue one at a time. Do not try to make multiple corrections at the same time as you may contaminate the results, and possibly obscure important issues that need further attention.

Legend:

BL = Bullet Length
BD = Bullet Diameter
C = 150 constant for muzzle velocity 1500-2800 FPS
C = 180 constant for muzzle velocity over 2800 FPS
(choose the correct constant for the ammunition you are using)

Formula:

$$\frac{C}{\frac{BL}{BD}} \times BD$$

First divide the bullet diameter (for example .224) into the bullet length (for example .712). Divide the result into the correct constant (150 or 180) and multiply the result by the BD (for example .224). The results is the **approximate minimum twist rate** necessary to stabilize the bullet - Remember a 1:9 rate is faster than a 1:14 rate.

Example A: .223 (5.56 x 45) @ 3200 FPS, 52 Grain, BL= .712 BD=.224

$$\frac{180}{\frac{.712}{.224}} = \frac{180}{3.178} = 56.64 \times BD = 56.64 \times .224 = 12.7$$

12.7 is the optimum rate of twist

Example B: .223 (5.56 x 45) @ 2500 FPS, 75 Grain, BL= 1.095 BD=.224

$$\frac{150}{\frac{1.095}{.224}} = \frac{150}{4.9} = 30.6 \times BD = 30.6 \times .224 = 6.86$$

6.9 is the optimum rate of twist

If you use the 52 grain bullets in a 7.0 twist barrel the result will be fairly accurate. If you use the 75 grain bullet in a 12.0 or 13.0 twist barrel your group will probably be all over the target.

Diameters of Popular Bullets

| | |
|-------------|-------------|
| .204 - .204 | 7mm - .284. |
| .223 - .224 | .308 - .308 |
| .243 - .243 | .338 - .338 |
| .270 - .277 | .375 - .375 |

Note: 7.5:1 is about the fastest you will find in any barrel. Even though calculated results may indicate a faster rate, too fast will cause the bullet to disintegrate. At 3000 FPS in a slow 1:12 twist barrel a bullet spins at about 90,000 RPM.

Bullet length varies by manufacturer and style. For this information check with the manufacturer or take an actual measurement.

C. A perfectly formed muzzle crown allows the gas to escape in a uniform pattern around the base of the bullet as it exits. Through improper cleaning and handling the crown of the muzzle can be easily damaged. Even a small ding, which may not necessarily be visible to the naked eye, can cause an uneven release of gas, which can heel the bullet over slightly, producing a yaw attitude. This will affect the bullet's stability and accuracy, as the long axis of the bullet will no longer be coincidental with the path of travel.

D. The quality of the ammunition you use can have a direct result on repeatable group size; the more consistent the ammunition, and the components from which it is manufactured, the more consistent the results. Several manufactures make match grade ammunition where the components are carefully selected and screened for consistency and conformance to specification. (One of the manufacturers that are best known for achieving the most consistent results is Black Hills www.black-hills.com). There are several other manufacturers that make acceptable match grade ammunition, and there are other options. If you are a re-loader, you are already aware of the range of quality components available and in all probability you are able to produce consistent, high quality ammunition.

E. Vertical Grouping – See Rim Fire section point D.

F. Check Your Scope and Mounting – With older and especially inexpensive scopes it is not uncommon for the reticle to stick or shift, especially under heavy recoil and/or temperature extremes. If this happens your muzzle could end up pointing in a slightly different direction after each shot. To check for this condition, lock the gun in a vise that doesn't move and sight the reticle on a set point/target then use a piece of wood or other object (that will not do damage), to tap the scope tube to imitate recoil. If the reticle moves from the original point of aim, you have a problem with the scope. Also check the scope mounting using the same procedure. Mounts and rings frequently become loose due to recoil and heat. In addition to properly mounting a scope the rings must be lapped and centered otherwise there may not be sufficient contact to secure the scope. Even Locktite doesn't insure that mounts and rings will not shift.

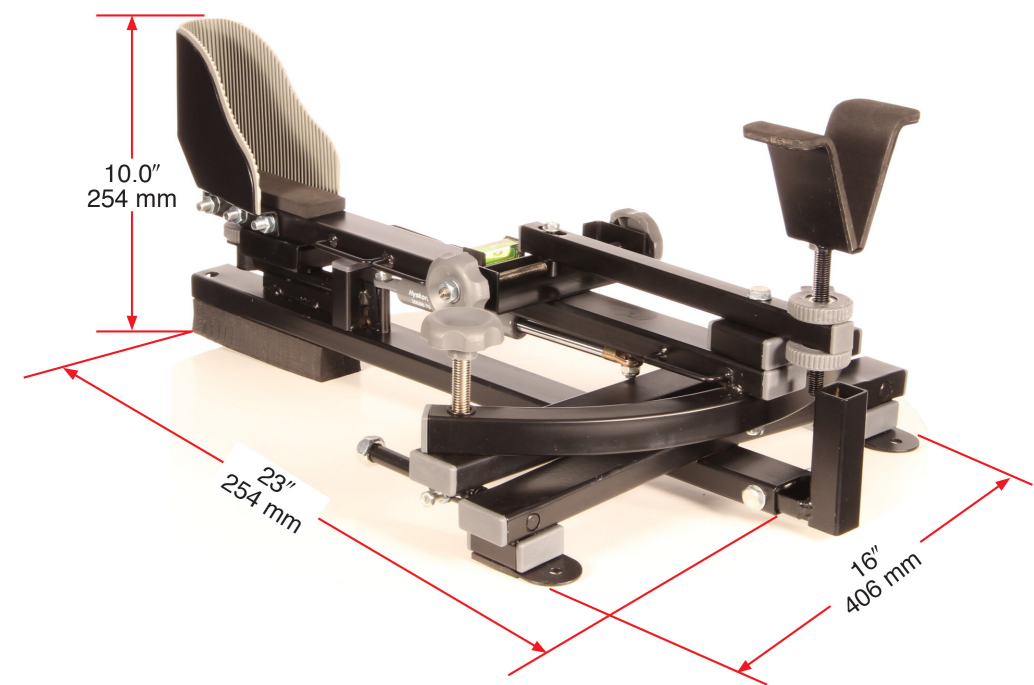
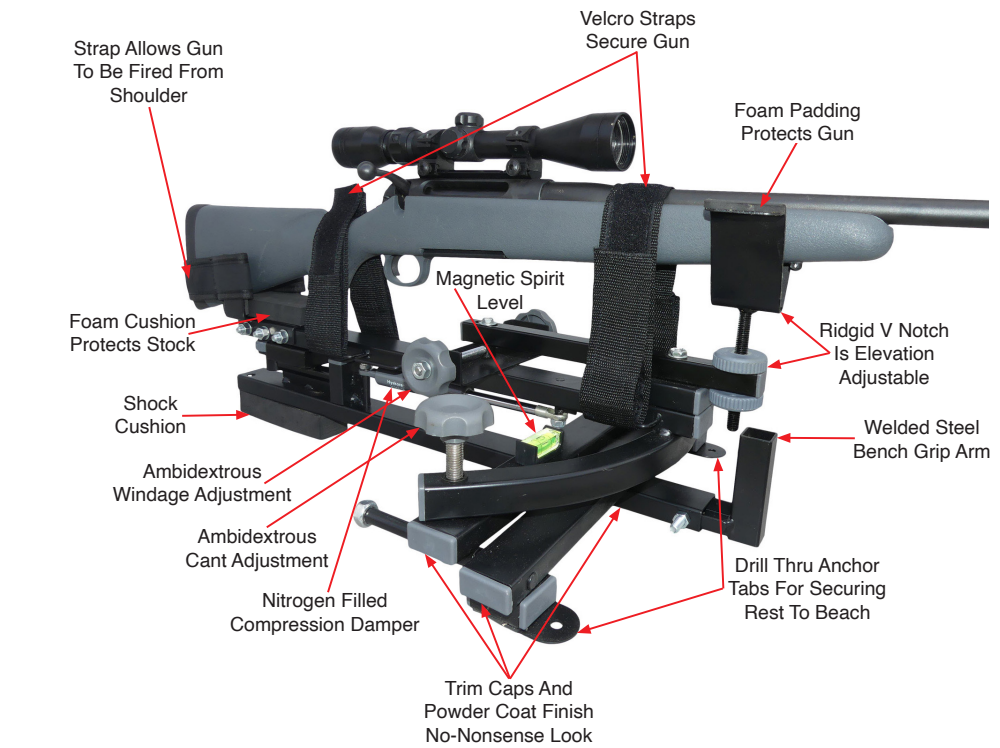

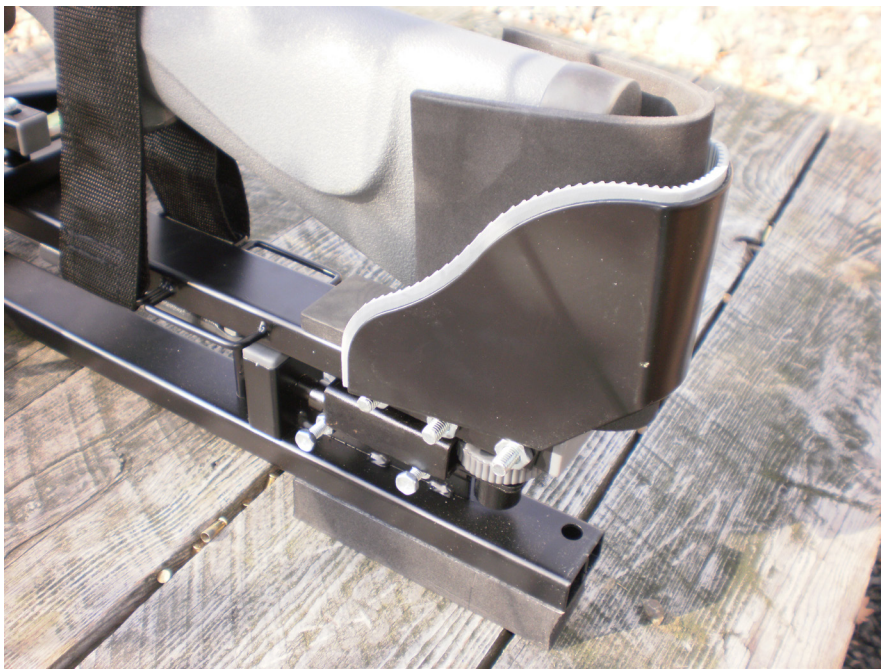

Use the large pads to firmly wedge the stock into the butt socket



If you're going to use light recoiling guns, such as .22 - 250 or .223/.556, you will need to purchase the spring pack and install them after disconnecting the damper.

A WORD ABOUT ACCURACY

When it comes to shooting, the word "accuracy" really refers to group size. Once the group is established, adjusting the sights to move the point of impact to the point of aim is a simple task. A gun/ammunition combination that shoots to 1, 3, or 5 MOA is just that. No matter what device you use to support the gun that group size will not change, not to mention extraneous factors such as sighting device, wind, stability of the shooting platform, trigger pull, parallax and/or the shooter. There is a long list of factors that can affect group size. Below we have attempted to briefly address a few of the more common ones. All comments are made with the "all things being equal" and "under perfect conditions" provisos. Please consider this a general guide that might point out a few things that might not have come to mind. Our #30013 Dangerous Game®, #30003 Precision Rifle Rest and #30088 DLX Precision Rifle Rest are designed to produce repeatable results. If the rests are properly assembled, securely anchored to a bench that is rock solid and does not shift under the stress of recoil, you will be able to maximize repeatability. Each rest will consistently repeat well under 3 MOA. What this means is that if the gun/ammunition combination is capable of shooting groups of less than 3 inches at 100 yards (nominal 3 MOA), you will be able to realize this degree of repeatability with either rest. The big word in the previous sentence is "IF". Neither rest will make a 3 MOA gun place all of the bullets in one hole. The group will still be 3 MOA. If your bullets are not all forming a tight group, there is a high probability that the problem is a result of the gun, ammunition and/or the sight.

* MOA-Minute of arc - A circle has 360°, each degree has 60 minutes, i.e. 1/60th degree. 1.0 MOA is exactly 1.047 inches at 100 yards

CENTER FIRE ACCURACY

A large percentage of the rifles, old and new, in the hands of American sportsmen will not shoot much better than 2.5 MOA with exceptional guns shooting 1.0- 1.5 MOA, (assuming the ammunition is correctly matched to the gun). The average deer rifle, using popular brand, off the shelf ammunition is probably capable of 2.5-3.0 MOA because the gun and ammunition manufacturers know that a typical white tail is statistically harvested at a range of less than 100 yards, and a gun that places the bullets within 3 MOA will easily place all of them within a heart sized circle. Manufacturing guns and ammunition that will shoot under 1 MOA is, of course, done every day. There are only a few manufacturers that guarantee that result, and then only with ammunition that they specify. The costs associated with the manufacturing, quality control, and attention to detail, price these guns out of reach of a large part of the market. With that being said, a gun/ammunition combination with 3 MOA accuracy, properly sighted in, will usually get the job done and nobody will know the difference. The target is dead - end of story. The point here is that if your gun is shooting at or beyond 3 MOA, the issue is, in all probability, a combination, of factors that can affect accuracy. We have prepared a short list of issues you may want to consider in examining the group size of your rifle.

- A. Bolt action sporting rifles are by nature and design typically more accurate than pump, lever, or semiautomatic rifles. The reason for this is the bolt action tends to be much more rigid, and therefore flexes less. In addition, a bolt action usually has a larger and stronger extraction mechanism, which means the chamber can be made to closer tolerances than other types of actions. Believe it or not, not all ammunition in the same caliber is made to the exact same dimensions by all manufacturers. For example, SAAMI (Sporting Arms and Ammunition Manufacturers Institute, www.saami.org publication ANSI/SAAMI Z299-1992) allows a variance of up to -.008 under the standard for diameter, and up to -.007 under for the standard distance from the base to the shoulder (this determines headspacing) for center fire 30-06 ammunition. (Variances across most calibers are similar.) The extraction mechanism in pump, lever, and especially in semi-automatic weapons must be able to consistently and effectively extract cartridge cases at a rate equal to the cyclic rate of the weapon using the entire range of commercially available ammunition. This can be problematic if the cartridge fits too tight in the chamber. As a result manufacturers tend to make these chambers more tolerant of ammunition that may tend towards the larger end of the size range. Conversely, if ammunition manufacturers want their product to function in guns typically in the hands of sportsmen, they must also consider how easily the cartridge seats and extracts. Needless to say, there are exceptions to this, but as a rule as you move away from a precise cartridge chamber fit accuracy suffers. This is especially apparent in military weapons because they must chamber ammunition from various sources (therefore with various tolerances) and must function even if the ammunition is corroded or dirty. Reliability, not pinpoint accuracy is the primary criteria.
- B. Match the correct bullet weight to the twist of the rifling. This is one of the most commonly overlooked factors that determines group size. If the bullet length and twist rate of the barrel are not synchronized, accuracy will suffer. A 110 grain .308 bullet is, of necessity, shorter than a 220 grain .308 bullet. For proper stabilization the heavier, and hence longer bullet, requires a faster rate of rifling twist than a short, light bullet. Further to this point, different guns respond differently to ammunition from different manufacturers. The point here is that you should test fire ammunition from several manufacturers and select bullet weights that are compatible with the rate of twist of the gun's rifling. Generally speaking, twist rate is stamped on the barrel or the information is available from the manufacturer. You need to test different bullet weights to optimize results.) The following websites will give you more information regarding this issue:

1. <https://shooterscalculator.com/recoil-calculator.php>
2. <https://bisonballistics.com/calculators/recoil>
3. <https://www.omnicalculator.com/physics/recoil-energy>
4. http://huntamerica.com/recoil_calculator/
5. <https://jbmballistics.com/cgi-bin/jbmrecoil-5.1.cgi>