

WORKHORSE

S P R A Y E R S

by PSE®, a Division of Green Leaf, Inc®

Assembly / Operation Instructions / Parts

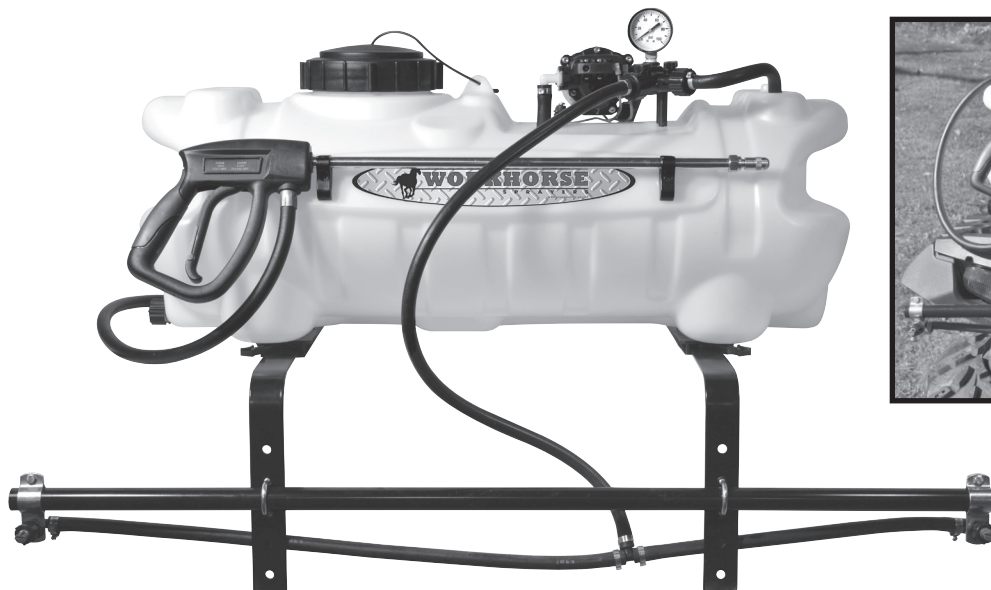

ATV 1502

ATV 2502

MODEL # ATV 1502 and ATV 2502

DELUXE ATV 2 NOZZLE SPRAYER

- Polyethylene Tank
- 2 Nozzle Boom Assembly
- 12 Volt Diaphragm Pump
- 2.2 G.P.M.
- Quick Attach Mounting System
- 80 inch coverage with Check Valve and Filter
- Lever Handgun
- 15 Ft. of 3/8" Hose (Handgun)
- Pressure Gauge
- Adjustable Pressure Range (0-60 PSI Max.)

— GENERAL INFORMATION

The purpose of this manual is to assist you in assembling, operating and maintaining your lawn and garden sprayer. Please read it carefully as it furnishes information which will help you achieve years of dependable trouble-free operation.

— ASSEMBLY INSTRUCTIONS

Tools required:

- 2 — 7/16" End Wrenches
- 1 — 9/16" End Wrench
- 1 — Thread Sealant
- 1 — Blade Screwdriver
- 1 — 3/16" Allen Wrench

— WARRANTY / PARTS / SERVICE

Workhorse products are warranted for one year from the date of purchase against manufacture or workmanship defects for personal or homeowner usage with proof of purchase. Workhorse products are warranted for 90 days for commercial users. Any unauthorized modification of a Workhorse brand sprayer will void warranty.

Your authorized dealer is the best source of replacement parts and service. To obtain prompt, efficient service, always remember to give the following information: 1) Correct part description and part number. 2) Model number and serial number of your sprayer.

Part description and part numbers can be obtained from the illustrated parts list section of this manual.

Whenever you need parts or repair service, contact your distributor / dealer first. For warranty work always take your original sales slip, or other evidence of purchase date, to your distributor / dealer.

WARNING: Some chemicals will damage the pump valves if allowed to soak untreated for a long period of time. Always flush the pump with water after use. Do not allow chemicals to sit in pump for extended times of idleness. Follow chemical manufacturers instructions on disposal of all waste water from the sprayer.

— OPERATION

The pumping system draws solution from the tank, through the strainer and to the pump. The pump forces the solution under pressure to the boom nozzles and spray wand.

The pump has a pressure switch which will shut the pump off when it reaches 60 PSI.

Pressure may be regulated by opening or closing the valve located on the top of the tank. See "Valve Operation" illustrated in this manual.

The nozzles on the boom will spray an 80 inch wide swath. Check the nozzle spray pattern by spraying water on a concrete surface.

Regularly inspect the suction supply screen on the inside of the tank. Flush with water to clear any accumulated debris.

— CALIBRATION

Chemical labels may show application rates in gallons per acre, gallons per 1000 square feet or gallons per 100 square feet. You will note that the tip chart shows all three of these rating systems.

Once you know how much you are going to spray then determine (from the tip chart) the spraying pressure (PSI), and the spraying speed (MPH).

Conditions of weather and terrain must be considered when setting the sprayer. Do not spray on windy days. Protective clothing must be worn in some cases. **Be sure to read the chemical label carefully.**

For the best spray pattern coverage, the nozzles may be rotated rearward 15°.

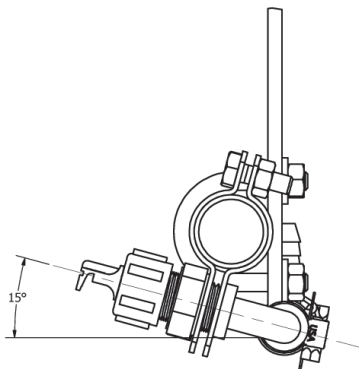

To determine the ground speed of your sprayer, measure and mark driving distances of 100, 200, or 300 feet. Our speed chart indicates the number of seconds needed to travel these distances. Set your throttle, and with a rolling start, drive the measured distance of your choice. Adjust your throttle until you can match the number of driving seconds needed. Mark the throttle setting and note the gear range so you can use them while spraying.

Add water and chemicals in the proper amounts in the spray tank and drive to your starting point. When you are ready to spray, turn your boom control valve to the "ON" position. Once the pump is turned on, the unit will begin spraying. The system pressure will decrease slightly when you see solution flowing from the spray nozzles. This is normal, the pressure will return as before when you turn the control valve to the "OFF" position.

You will find optimal spraying in the 20 to 30 PSI range.

WARNING: This product can expose you to chemicals including lead, which is known to the State of California to cause cancer. www.P65Warnings.ca.gov

— AFTER SPRAYING

After use, fill the sprayer part way with water. Start the sprayer and allow clear water to be pumped through the plumbing system and out through the spray nozzles.

Refill the tank about half full with plain water and use a chemical neutralizer such as Nutra-Sol® or equivalent and repeat cleaning instructions. Flush the entire sprayer with the neutralizing agent. Follow the chemical manufacturer's disposal instructions of all wash or rinsing water.

Remove tips and screens from the boom. Wash tips thoroughly with water or cleaning solution (appropriate for chemical used). Blow out orifice, clean and dry. If orifice remains clogged clean it with a fine bristle (not wire) brush, or with a toothpick. Do not damage the orifice. Water rinse and dry tips before storing.

— WINTER STORAGE

Drain all water and chemical out of sprayer, paying special attention to pump and valves. These items are especially prone to damage from chemicals and freezing weather.

The sprayer should be winterized before storage by pumping a solution of RV antifreeze through the entire plumbing. Proper care and maintenance will prolong the life of the sprayer.

— TIP CHARTS

Tip No.	Spray Height	Pressure (PSI)	Capacity (GPM)	GALLONS PER ACRE - BASED ON WATER						
				1 MPH	2 MPH	3 MPH	4 MPH	5 MPH	7.5 MPH	10 MPH
3	18"	10.0	0.30	44.0	22.0	14.9	11.1	08.9	05.9	4.50
		20.0	0.42	63.0	31.5	20.9	15.7	12.6	08.4	6.30
		30.0	0.52	76.0	38.0	26.0	19.3	15.4	10.3	7.70
		40.0	0.60	90.0	45.0	30.0	22.0	17.8	11.8	8.90
Tip No.	Spray Height	Pressure (PSI)	Capacity (GPM)	GALLONS PER 1000 SQ. FT. - BASED ON WATER						
				1 MPH	2 MPH	3 MPH	4 MPH	5 MPH	7.5 MPH	10 MPH
3	18"	10.0	0.30	1.01	0.50	.340	.254	.204	.135	.103
		20.0	0.42	1.40	0.72	.480	.360	.290	.190	.140
		30.0	0.52	1.74	0.87	.596	.440	.350	.236	.176
		40.0	0.60	2.06	1.00	.688	.500	.408	.270	.200
Tip No.	Spray Height	Pressure (PSI)	Capacity (GPM)	GALLONS PER 100 SQ. FT. - BASED ON WATER						
				1 MPH	2 MPH	3 MPH	4 MPH	5 MPH	7.5 MPH	10 MPH
3	18"	10.0	0.30	.100	.050	.034	.025	.020	.013	.010
		20.0	0.42	.140	.072	.048	.036	.029	.019	.014
		30.0	0.52	.174	.087	.059	.044	.035	.0236	.017
		40.0	0.60	.206	.100	.068	.050	.040	.027	.020

Tip No.	Pressure (PSI)	Capacity (GPM)	GALLONS PER ACRE BASE ON WATER-40" SPACING			
			5 MPH 440 FPM	6 MPH 528 FPM	7 MPH 616 FPM	8 MPH 704 FPM
5	10	0.50	14.9	12.4	10.6	9.3
	20	0.71	21.0	17.6	15.1	13.2
	30	0.87	26.0	22.0	18.5	16.1
	40	1.00	30.0	25.0	21.0	18.6

Most chemical labels indicate a chemical application rate in 1,000 sq. ft.; if the rate on the label is indicated as a rate per acre, divide the per acre rate by 43.56 to convert to a rate per 1,000 sq. ft.

1 Acre = 43,560 sq. ft.
 1 gallon per 1,000 sq. ft. = 43.56 gallons per acre
 1 fl. Oz. = 2 tablespoons
 1 cup = 8 fl. Oz.
 1 pint = 2 cups = 16 fl. Oz.
 1 quart = 2 pints = 32 fl. Oz.
 1 gallon = 4 quarts = 8 pints = 128 fl. oz.

— SPEED CHART

Speed in MPH (Miles Per Hour)	Time Required in Seconds to Travel a distance of:		
	100 ft.	200 ft.	300 ft.
1.0	68.0	136	205
2.0	34.0	68	102
3.0	23.0	45	68
4.0	17.0	34	51
5.0	14.0	27	41
6.0	11.0	23	34
7.0	9.7	19	29
8.0	8.5	17	26
9.0	7.6	15	23
10.0	6.8	14	20

PSE
PRECISION SPRAY EQUIPMENT
a division of Green Leaf, Inc.

— GENERAL ASSEMBLY Instruction #1

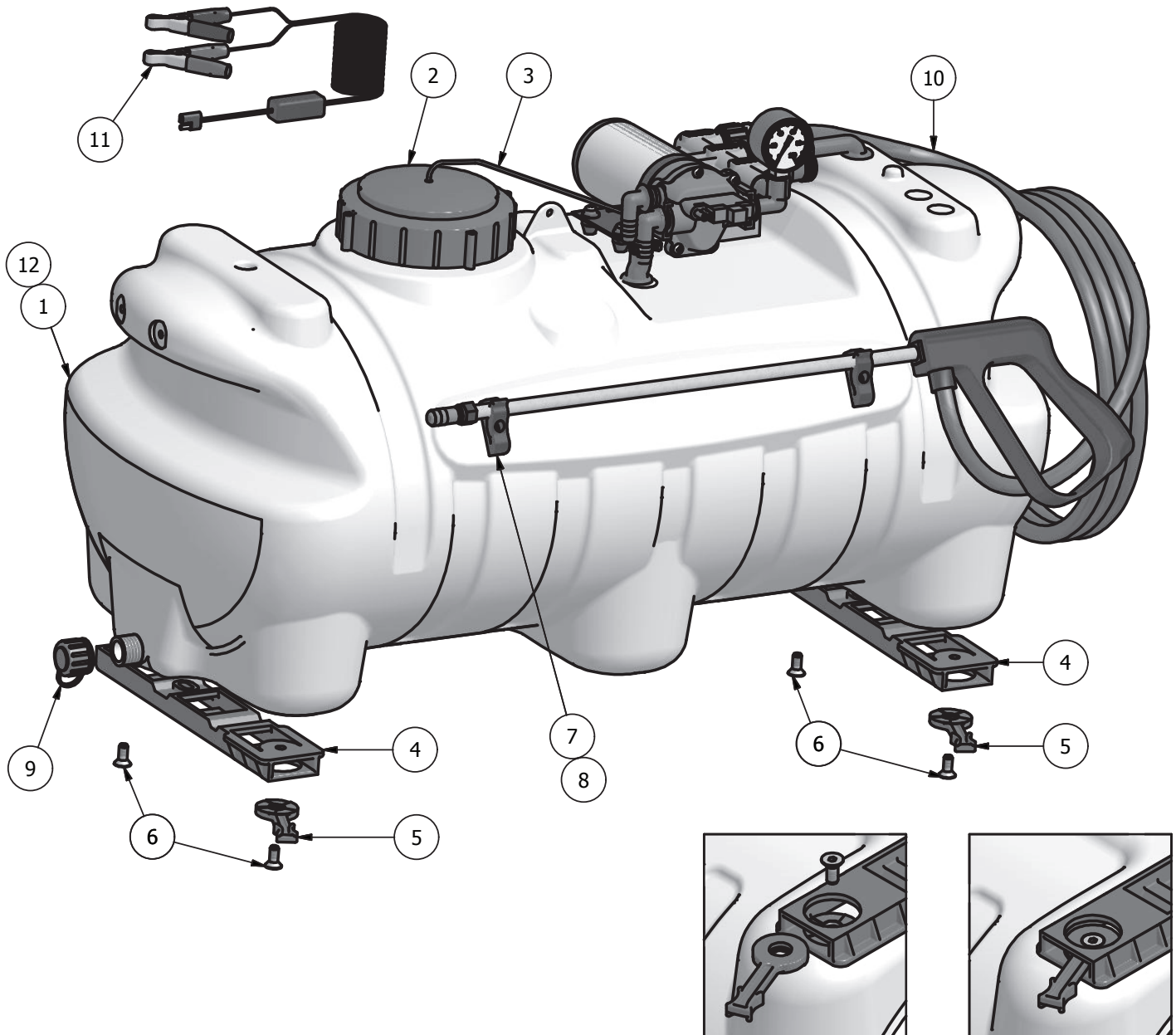

PARTS LIST

ITEM	QTY	PART NUMBER	DESCRIPTION
1	1	600132	25 Gallon Tank
2	1	600133	Tank Lid
3	1	600134	Tank Lid Tether
4	2	600189	ATV Boom Mount
5	2	600190	ATV Helix Lever
6	4	600188	5/16-18 Flat Head Screws
7	2	600151	Spray Wand Clip
8	2	600152	#10-24 x 3/8" Screw
9	1	600298	Drain Cap Assembly
10	1	600156	Deluxe Wand and 15ft Hose
11	1	600153	Lead Wire Assy. w/ Switch (96")
12	1	600239	15 Gallon Tank

Assembly Instructions

- 1.0--Install ATV Boom Mounts & ATV Helix Levers in two places on bottom of tank as illustrated using 5/16" Flat Head Screws. Note the orientation of all parts as their orientation is essential for proper assembly.
- 1.1--Install Drain Cap Assembly
- 1.2--Insert Lead Wire Assembly into plug at rear of the pump.
- 1.3--Join the red wire of the two wire cable to a +12v source such as a switch, ammeter, or positive battery post. The black wire should be grounded or connected to the negative battery post

— SPRAY BOOM ASSEMBLY

- 2.0--Insert ATV Angle Brackets into ATV Mounts as Illustrated
- 2.1--Attach Spray Boom Assembly to ATV Angle Brackets using U-Bolts with nuts at desired height.
- 2.2--Install Boom Clamps onto each end of the Spray Boom Assembly and tighten screws. (screws should be on top of the Spray Boom)
- 2.3--Install Hose Clamps over each end of the Boom Hose assembly as illustrated and press hose ends onto NTL38P Fittings. Then tighten down Hose Clamps to secure the fittings to the Hose Assembly.
- 2.4--Insert the NTL38P Fittings through the the holes on the Boom Clamps that were previously installed on the Spray Boom. Secure in place with N1116 P Nuts.
- 2.5--Insert Check Valves/Strainers into the NTL38P Fittings.
- 2.6--Insert Spray Tips into 8027 P Nuts and then screw nuts onto fittings. (assume that tips are oriented downward to achieve the correct spray pattern).

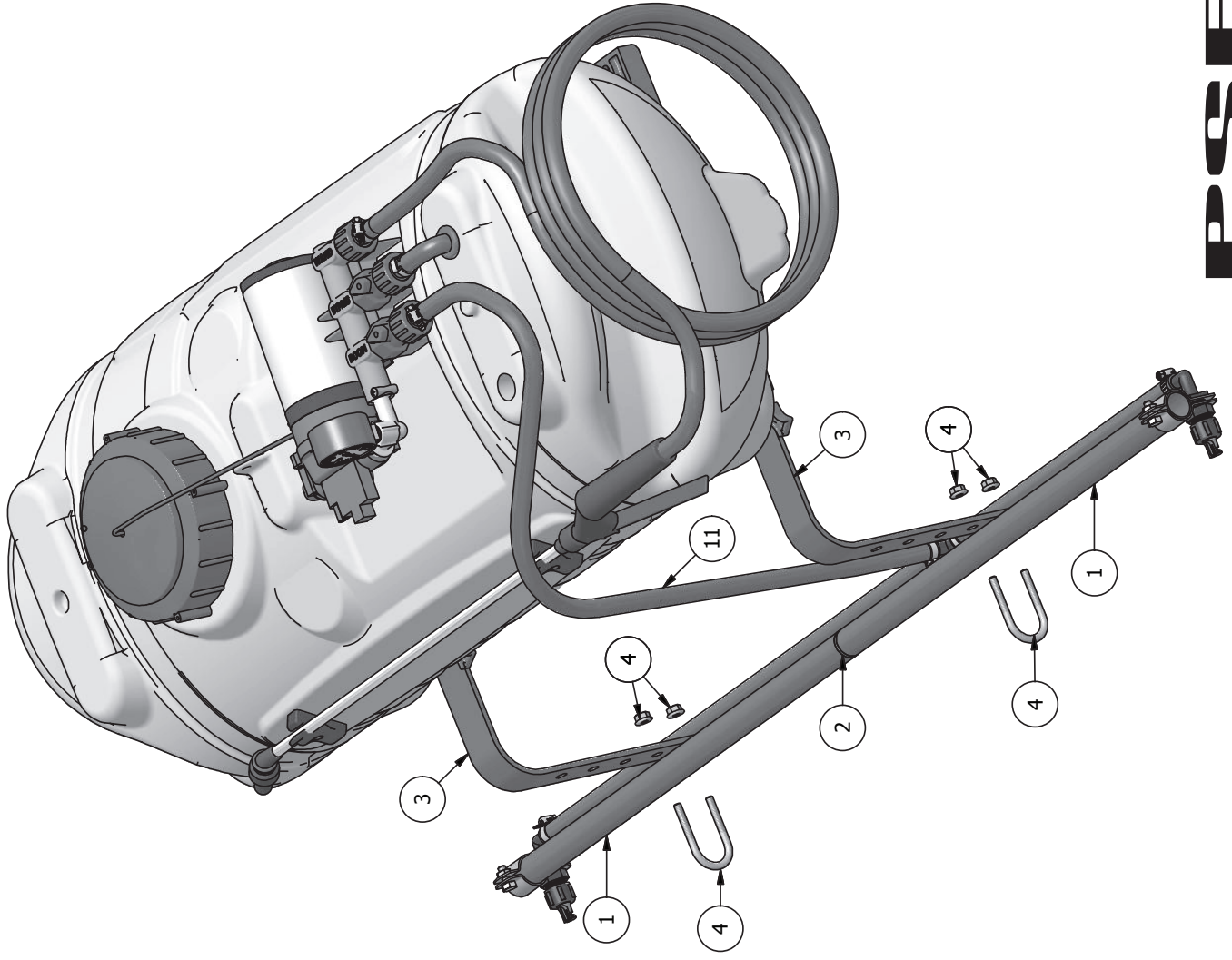
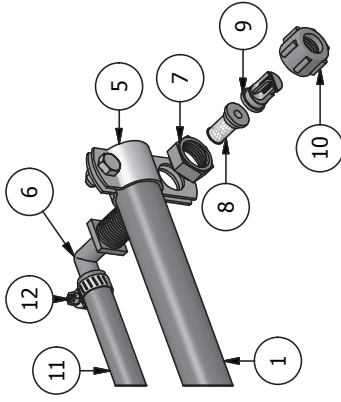

PARTS LIST

ITEM	QTY	PART NUMBER	DESCRIPTION
1	2	630022	Spray Boom Assembly
2	1	600256	Boom Insert
3	2	600191	ATV Angle Bracket
4	2	600169	φ1/4" U-Bolt w/ Nuts
5	2	600113	B 11-34 R
6	2	600112	NTL38 P Fitting
7	2	600116	N1116 P Nut
8	2	600117	Check Valve / Strainer
9	2	600118	FT Spray Tip
10	2	600119	8027 P Nut
11	1	600115	Boom Hose Assembly
12	4	600120	5/8" Hose Clamp

– Pump & Valve Assembly

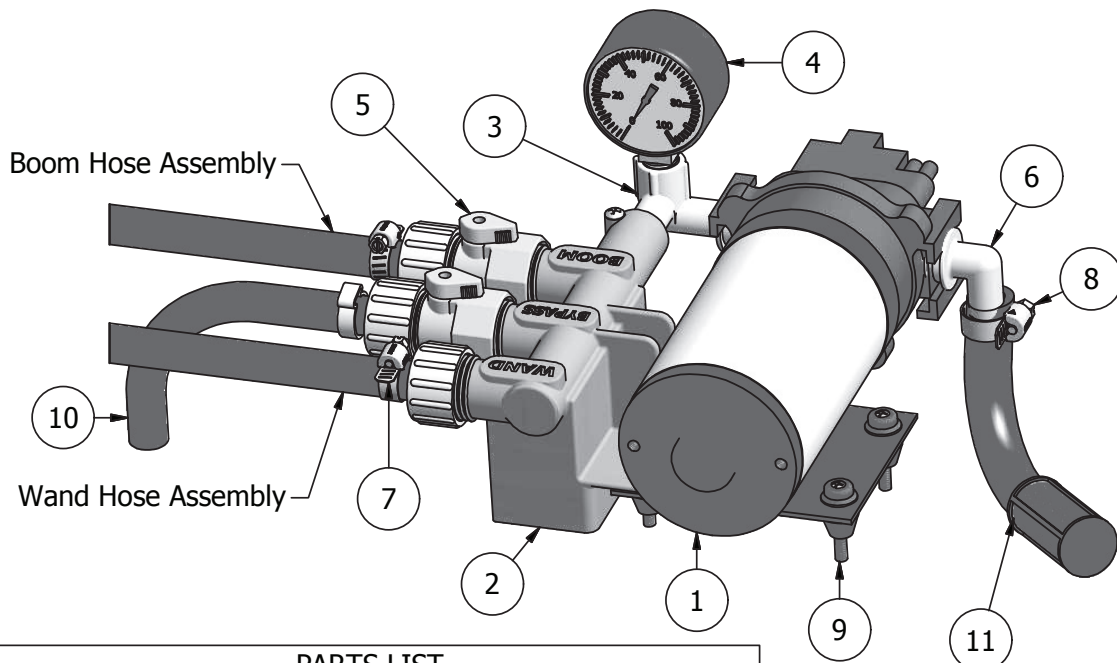

PARTS LIST			
ITEM	QTY	PART NUMBER	DESCRIPTION
1	1	640451	2.2 GPM Pump*
1	1	630201	4.0 GPM Pump*
1	1	630031	5.0 GPM Pump*
2	1	600289	Manifold Body
3	1	600291	Elbow (2.2 pumps)
3	1	600292	Elbow (4.0 & 5.0 pumps)
4	1	600129	Gauge 0-100 PSI
5	2	600216	Inline Valve
6	1	600287	QD EL 12
7	2	600120	5/8" Hose Clamp
8	1	600288	1/2" Hose Clamp
9	4	600130	10-24 x 1.25 Screw
10	1	600213	Relief Hose Assembly
11	3	600315	Suction Hose Assembly
12	1	600298	Cap Assembly (not shown)

Install Wand Hose Assembly onto Swivel Barb Assembly, by placing a Hose Clamp over the open end of the hose on the Wand Hose Assembly. Then pressing the open end of the hose onto the Swivel Barb Assembly like shown. Secure in place by tightening the Hose Clamp as shown.

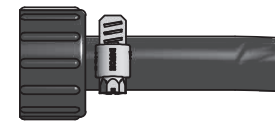
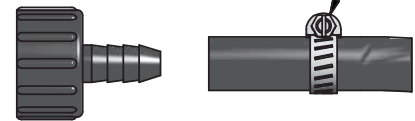

*Pump included depends upon model purchased.

The Lever adjusts the system pressure by relieving liquid back to the tank. Adjusting this lever will increase or decrease pressure to both the spray wand and the spray boom.

The lever turns the spray boom on and off

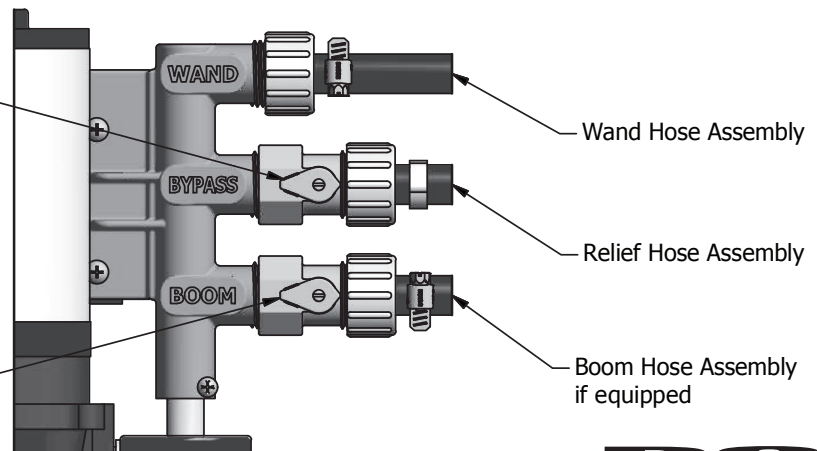

PowerFLO™ 7800 Series

12 Volt DC Motor-Driven Diaphragm Pumps



Model: 7802: 2.2 GPM

Specifications —

Motor:

Type: 12 VDC, permanent magnet, totally enclosed, non-ventilated

Leads: 18 AWG, 12" long

Duty Cycle: See Heat Rise graph

Temperature Limits: Motor is not equipped with thermal protection. For user safety, optimal performance, and maximum motor life, the motor surface temperature should not exceed 150°F (66°C) (see Heat Rise graph above right).

Pump:

Type: 3 chamber positive displacement diaphragm pump, self priming, capable of being run dry, demand or bypass model.

Certifications: NSF Standard 58

Liquid Temperature: 140°F (60°C) Max.

Priming Capabilities: 14 feet (4 m)

Max Pressure: 60 PSI

Inlet/Outlet Ports: 7802: Quick Attach

Materials of Construction:

Housing: Polypropylene Diaphragm: Santoprene

Valves: Viton Fasteners: Stainless steel

Weight: 6 lbs (2.7 kg)

Installation and Operation Precautions —

1. The pump is equipped with a pressure sensing demand switch that controls the maximum operating pressure.
2. In addition, never subject the pump to pressures above 125 PSI (8.5 bars).
3. As long as there is inlet water pressure, the pump will not stop forward flow of water even if the motor is turned off. Be sure the system has positive means of shutting off water supply.
4. Do not operate pump in an explosive environment. Arcing from the motor brushes, switch or excessive heat from an improperly cycled motor may cause an explosion.
5. Do not locate the pump motor near low temperature plastics or combustible material. The surface temperature of the motor may exceed 250°F (120°C).
6. Do not pump gasoline or other flammable liquids. Pump head materials are designed for use with water only. Do not use with petroleum products.
7. Do not assume fluid compatibility. If the fluid is improperly matched to the pumps' elastomers, a leak may occur.
8. To prevent electrical shock, disconnect power before initiating any work. In the case of pump failure, the motor housing and/or pump fluid may carry high voltage to components normally considered safe. Therefore, always consider electrical shock hazard when working with and handling electrical equipment. If uncertain, consult an electrician. Electrical wiring should only be done by a qualified electrician per local and state electrical codes.

Heat Rise

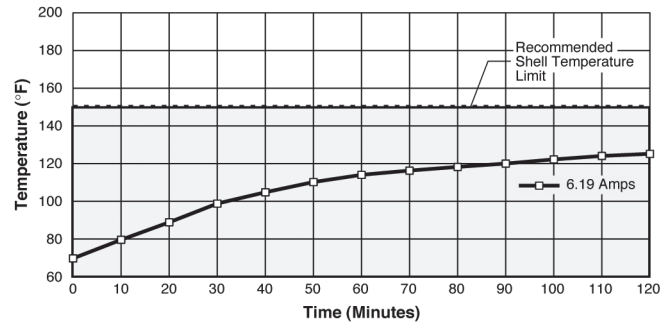

Approximate values, actual values will vary with ambient temperature.

Pressure Sensing Demand Switch —

The PowerFLO Series 7800 pump is controlled by a built-in pressure sensing demand switch. When a faucet or valve is opened down stream of the pump, line pressure drops thus starting the pump automatically. Conversely, when the valve shuts, the line pressure increases turning the pump off automatically. The pressure switch actuates in response to the pump outlet pressure at a predetermined and preset pressure. The pump label indicates the predetermined ON and OFF pressures. Typically, the OFF pressure is accurately set at the Factory and the ON pressure is within an allowable range below that value. In response to the characteristics of the system in which the pump is installed, the flexibility and length of the tubing, the faucet or valves and the duration that they are open; these pressure settings may vary. Therefore, variation in pressure setting is expected with use and over time.

Adjusting the Pressure Switch:

Should the pressure switch OFF setting vary with use and time to an unsuitable value, it may be adjusted for optimum performance. Turn the setscrew clockwise to increase the OFF pressure setting and counter clockwise to decrease. The screw should not be adjusted more than one half turn without consulting the Factory. Excessive adjustment of the pressure switch could cause low system pressure, rapid cycling ON/OFF operation, and reduced pump and motor life. Damage may occur. The Warranty does not cover improper adjustment of the pressure switch.

Servicing —

Every Year: Check system against operating standards.

Every 2-3 Years: We recommend replacing the diaphragm and checking against operating standards.

* Important return safety instructions:

When you return your pump for warranty or repair, you must always do the following:

1. Flush chemical residue from the pump (best done in the field).
2. Tag pump with type of chemicals having been sprayed.
3. Include complete description of operation problem, such as how pump was used, symptoms of malfunction, etc. Since pumps can contain residues of toxic chemicals these steps are necessary to protect all the people who handle return shipments, and to help pinpoint the reason for the breakdown.

Troubleshooting Guide —

Problem/Causes and Remedies:

Pump will not Start

Check:

- Correct voltage ($\pm 10\%$) and electrical connections
- Fuse or breaker
- Pressure switch operation and correct voltage at switch
- Rectifier or motor for open or grounded circuit
- Locked drive assembly

Pump will not Shut Off (Output line closed and no leaks)

Check:

- Air trapped in outlet line or pump head
- Correct voltage to pump
- Debris in pump inlet/outlet valves
- Loose drive assembly or pump head screws
- Pressure switch operations/adjustments

Pump will not Prime (No discharge with motor running)

Check:

- Debris in strainer
- Restriction (kinks) in inlet/outlet tubes
- Debris or swelling in inlet/outlet valves

Leaks from Pump Head or Switch

Check:

- Loose screws at switch or pump head
- Switch diaphragm ruptured or pinched
- Punctured diaphragm if fluid is present

Spray & Pump FAQs —

--Why does the pump not run all the time?

This is a demand pump and only runs with flow; spray wand, by-pass, spray tips or leak in system

--Why does the pump surge while using the spray wand?

Low flow may cause the pump to surge (or cycle). This could happen when the spray wand is adjusted for a small or fine spray pattern. To overcome, slightly open the by-pass valve.

--How do I adjust the pressure?

Pressure should be adjusted by regulating the by-pass valve (slightly opening or closing).

--What is the optimal operating pressure?

40 PSI - This can be accomplished by turning on the pump and adjusting the bypass valve until the gauge reads 40 PSI (or slightly higher). The pump will run continuously. Ensure that the boom and/or handgun is not spraying while you set the pressure. The pressure will drop slightly when the boom and/or handgun is operated.

--What pressure should the pressure gauge read?

Please refer to the operation instructions for boom operating pressures, varying boom pressures can be achieved by regulating or adjusting the by-pass valve. Typically the spray wand will be operated between 20 and 40 PSI.

--What is the recommended PSI to inflate the tires?

30 PSI Max

--My pump quit and will not restart - what should I check?

Check all electrical connections. Ensure switch is in the on position. Check in-line fuse and/or fuse in car adapter end. Ensure correct voltage +/- 10%. 12-13 volt

--Low flow or no flow at all - what should I check?

Check for a clogged suction hose and/or suction strainer. Often you will need to clean the suction strainer. Check for proper voltage.

--Is there a fuse for the sprayer?

Yes, either an in-line fuse, a fuse located in the car adapter housing or both.

--What size fuse should I use as a replacement?

7.5 amp

--What is the range of the spray wand?

35 feet max

--How should I clean the tank after use?

Tank should be cleaned with Nutrasol® or similar tank cleaning agent, and then rinsed with water.

--Is there an adjustment screw on the pump to adjust pressure?

Yes, please refer to the operation instructions, "Adjusting the Pressure Switch".

--How do I remove / replace fuse?

Unscrew in-line fuse connector, or unscrew the car adapter housing.

--Can the spray tip on the wand be replaced with a different type of tip?

Yes, however your wand comes with a #18 tip which is standard. Brass tips generally produce better spray patterns than plastic.

--Each time I turn on the pump my fuse blows.

1) Excessive voltage 2) Improper adjustment of the pressure switch 3) Damaged wiring harness.

--What is the warranty (time duration) on pump, tank, trailer pieces, and accessories?

1 year as stated in operation instructions.

--Pressure gauge reads 85 -90 psi before shutting off - should pump shut off at 60 psi?

Pump 7802 2.2 GPM comes preset from the factory to shut off at 60 PSI. Should this vary please see, "Adjusting the Pressure Switch" in the operation manual. Turn on pump and hold spray wand open, slowing adjust until the pump shuts off at 60 PSI.

--Pump continues to run and surge when not spraying.

Ensure the by-pass is completely closed and your system has no leaks. Check by-pass hose to ensure no fluid is passing through the valve while in the closed position. If so replace valve.

WARNING - Ensure the wiring harness does not become pinched or damaged in any way. This may damage the pump or cause the wiring harness to overheat, resulting in a melt down or fire.