

# Char-log<sup>®</sup>



# Aspen<sup>™</sup>

SERIES<sup>™</sup>



Recessed Hole



Pre-Checked

### IMPORTANT: READ CAREFULLY BEFORE BEGINNING

1. Do not tighten bolts until fully assembled.
2. Recessed holes to face outward.
3. Insert bolts with washer and secure with washer and nut.
4. Pre-checked side must always face downward or inward.

## BAR ARM CHAIR

ITEM # TX 93730, TX 93732, TX 93733, TX 51027, TX 95141

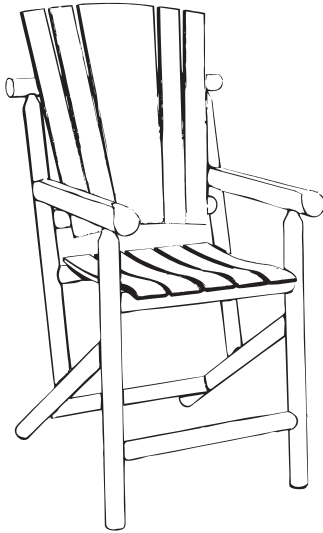

### PARTS AND HARDWARE LIST

1 AR55	2 FL90	3 DS80	4 VS92
ARM REST  X 2PCS	FRONT LEG  X 2PCS	DIAGONAL SUPPORT  X 2PCS	VERTICAL SUPPORT  X 2PCS
5 LSB59	6 STS	7 BKS	
LOWER SUPPORT BEAM  X 2PCS	SEAT  X 1PC	BACK  X 1PC	
Tools required for assembly		Tools included	
 Mallet  Socket & Wrench 13mm  Phillips Screwdriver		 Wrench  T-Handle Bolt	
		 NUT & BOLT X 16PCS	 SCREW X 6PCS

### STEP 1: Assembling the Rocker Arm Frame

Take one piece of the following parts with a letter "R" behind each number: 1, 2, 3, 4, 8 ("R" = Right)

- 1: Part 1 to part 4
- 2: Part 3 to part 2
- 3: Part 2 to part 1
- 4: Part 4 to part 3

Use indicated hardware, directed by diagram.

REPEAT steps 1 through 4 above using parts labeled with a letter "L" ("L" = Left) after the part number.

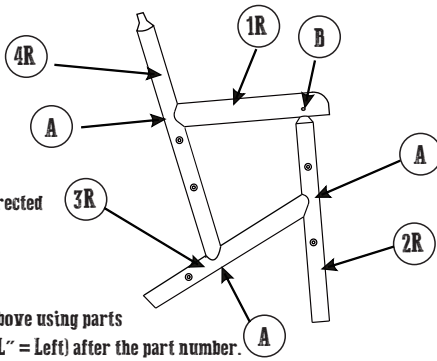

### STEP 2: Assembling the Bottom Half

Take assembled SEAT PANEL (6) and one of the arm frames. Keep the arm frame standing and attached the SEAT PANEL (6) to the inside of the arm frame, secure with the indicated nuts and bolts.

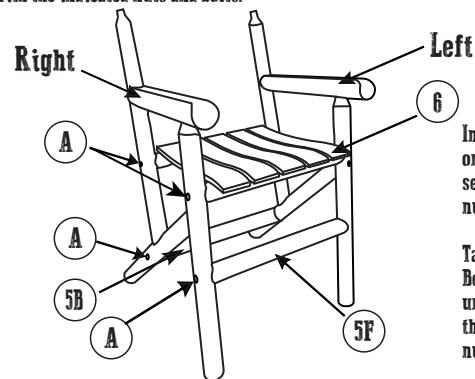

Insert the other arm frame on the other side and secure loosely with nuts and bolts.

Take the Lower Support Beam (5) and secure under the seat between the arm frame with nuts and bolts.

### STEP 3: Assembling the Upper Half

Once the bottom half is finished, take the BACK PANEL (7) and place it gently on part 4 of the arm frame.

Secure with indicated hardware in the diagram.

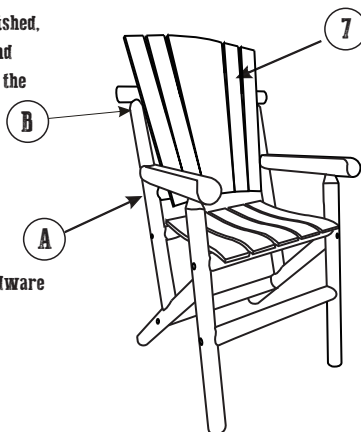

### STEP 4: Finish

Tighten all nuts, bolts, and screws once every part and assembled pieces are in place.

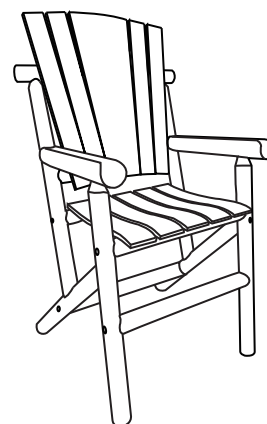

**Congratulations on your assembly!**

# Limited Warranty and Care Instructions

## LIMITED ONE YEAR WARRANTY (NON-TRANSFERABLE)

This product is covered under United General Supply's (UGS) one (1) year limited warranty. To the original purchaser of this piece of furniture, cooler or accessory; UGS warrants that it will be free from defects in material and workmanship for up to one year from the date of purchase under normal use and proper care.

Replacement of defective or missing parts will be sent at no charge to the customer for a period of 30 days from the date of purchase. UGS will no longer be responsible for missing parts or hardware 30 days after date of purchase. Freight, packaging, labor or material charges to and from our customer service center is not covered under the warranty and is therefore the customer's responsibility.

The limited warranty does not cover this piece of furniture, cooler or accessory for commercial purposes, abusive use, damage by modification, freeze damage, rust, fading and issues caused by improper care.

For minor defects or missing parts/hardware, please contact customer service immediately upon purchase. Please do not return product to the store unless you are completely unsatisfied with the product, or if the damage is irreparable. A customer service agent may help determine whether the damage is repairable and will provide further instructions. For returns and refunds, please refer to your local store with proof of purchase for such cases.

Proof of purchase (dated register receipt) will be required for warranty claims.

## PROPER CARE INSTRUCTIONS

If left untreated, wood will naturally weather. During long periods of non-use, store furniture or cooler in covered and dry place. For the least maintenance, place your furniture, cooler, or accessory under a covered area.

To preserve and maintain the original finish of Char-log/ Aspen log furniture, we recommend that a light lacquer coating be applied every 4 to 6 months depending on the seasons.

We recommended an exterior poly-urethane product that features a clear satin or semi-gloss finish and a fast drying process.

Customer Service may be reached Monday through Friday from 9:00a.m. to 5:00p.m. CST.

**HELP@UGSCO.COM OR 1-877-87LEIGH (53444)**



DISTRIBUTED BY:  
UNITED GENERAL SUPPLY CO., INC.  
HOUSTON, TX 77036

[www.LeighCountry.com](http://www.LeighCountry.com)