

**IMPORTANT: READ CAREFULLY BEFORE BEGINNING**

1. Do not tighten bolts until fully assembled.





**Leigh**   
**Country**  
 Authentic Country Living

**FOLDING ADIRONDACK TABLE**

ITEM # TX 39011 & TX 36604

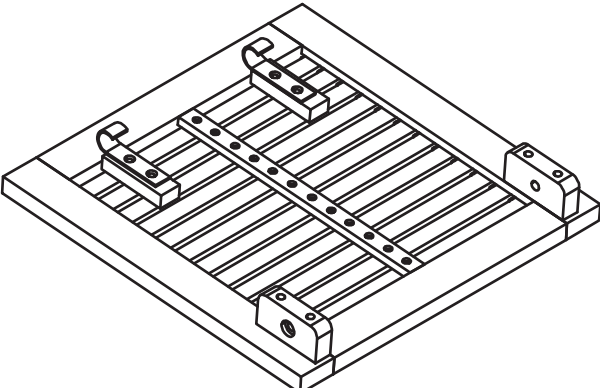
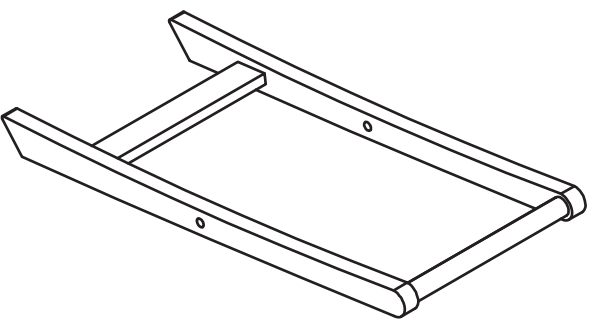
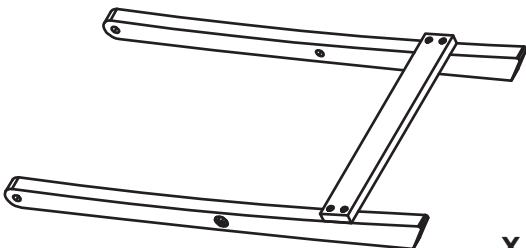
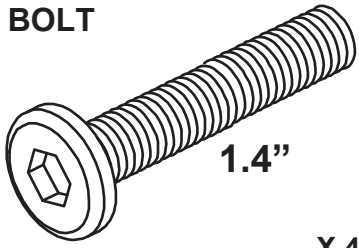
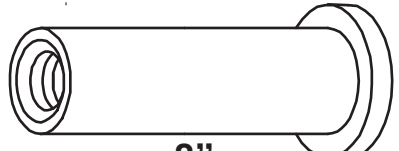
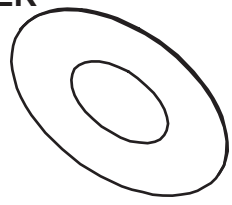
**PARTS AND HARDWARE LIST**

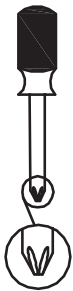
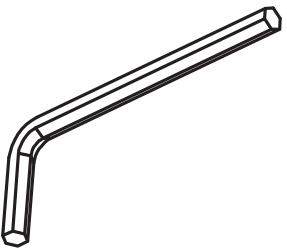
<p><b>① TABLE TOP</b></p>  <p>X 1pc</p>		<p><b>② RIGHT SIDE LEGS</b></p>  <p>X 1pc</p>	
<p><b>③ LEFT SIDE LEGS</b></p>  <p>X 1pc</p>	<p><b>Ⓐ M8x30</b> BOLT</p>  <p>1.4"</p> <p>X 4pcs</p>	<p><b>Ⓑ M8x15</b> BARREL BOLT</p>  <p>.8"</p> <p>X 4pcs</p>	<p><b>Ⓒ M8x19x2</b> WASHER</p>  <p>X 4pcs</p>
<p><b>Tools Required For Assembly</b></p>  <p>13mm Socket &amp; Wrench</p>  <p>Phillips Screwdriver</p>		<p><b>Tools Included</b></p>  <p><b>Do not use power tools because they may damage the hardware or split the wood.</b></p>	

# **STEP 1**

**Attach the Folding Legs (2+3) together with the Barrel Bolts (A+B) and Washer (C) through the center holes.**

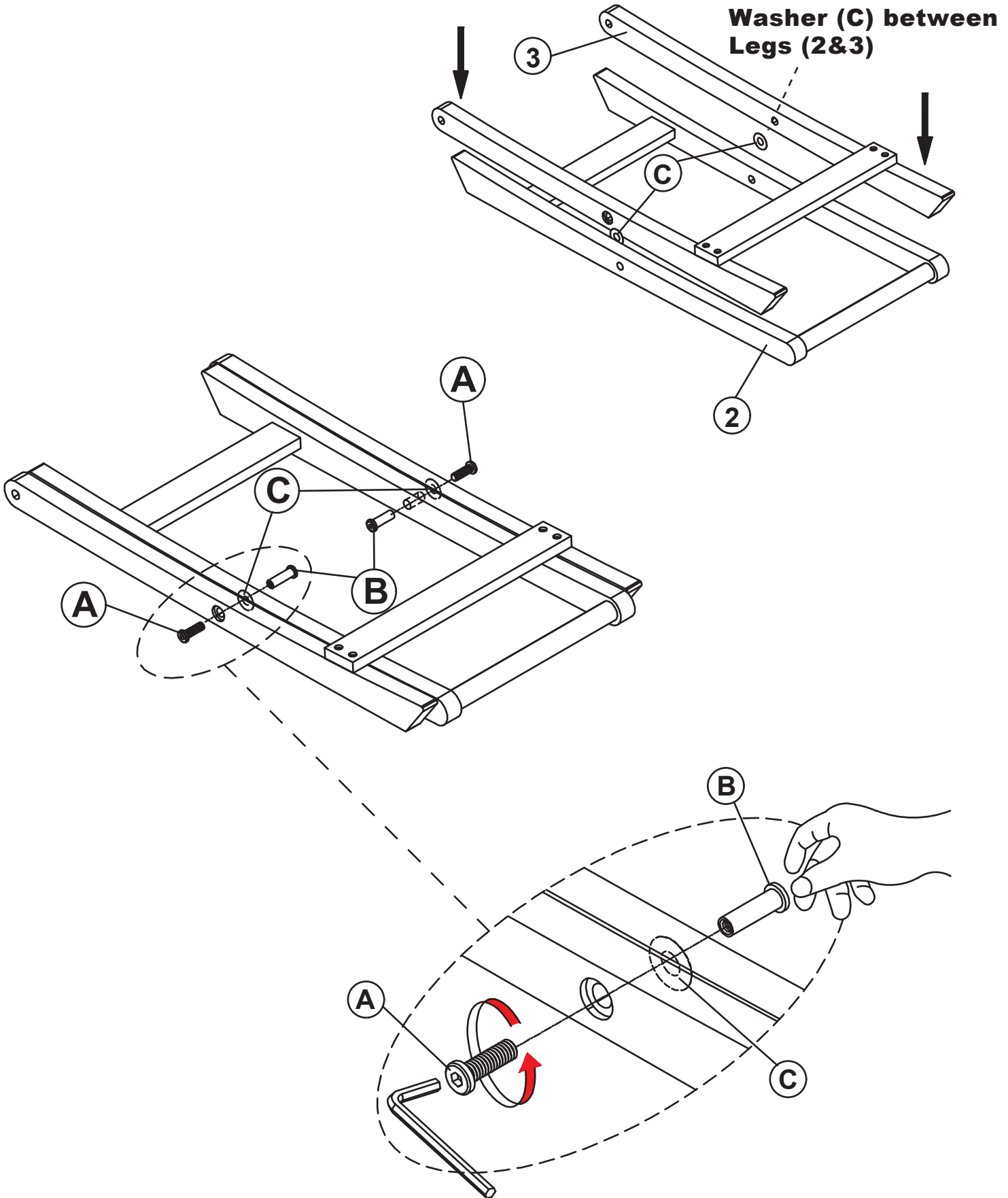

# STEP 2

Attach the Folding Leg (3) to the Table Top (1) with Barrel Bolts (A+B) and Washer (C).

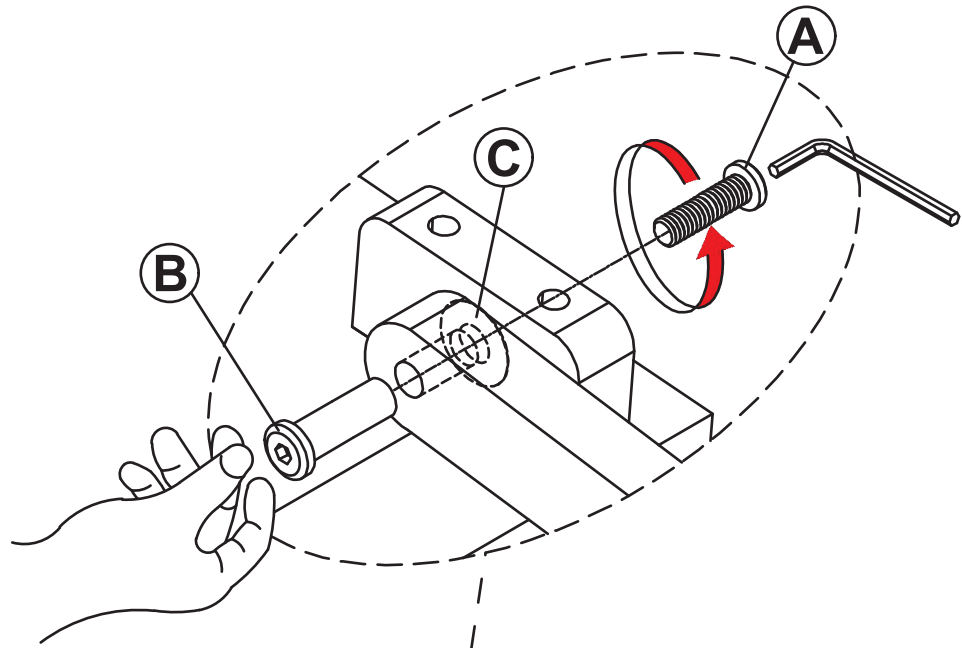

Washer (C) between Table Top (1) & Legs (3)

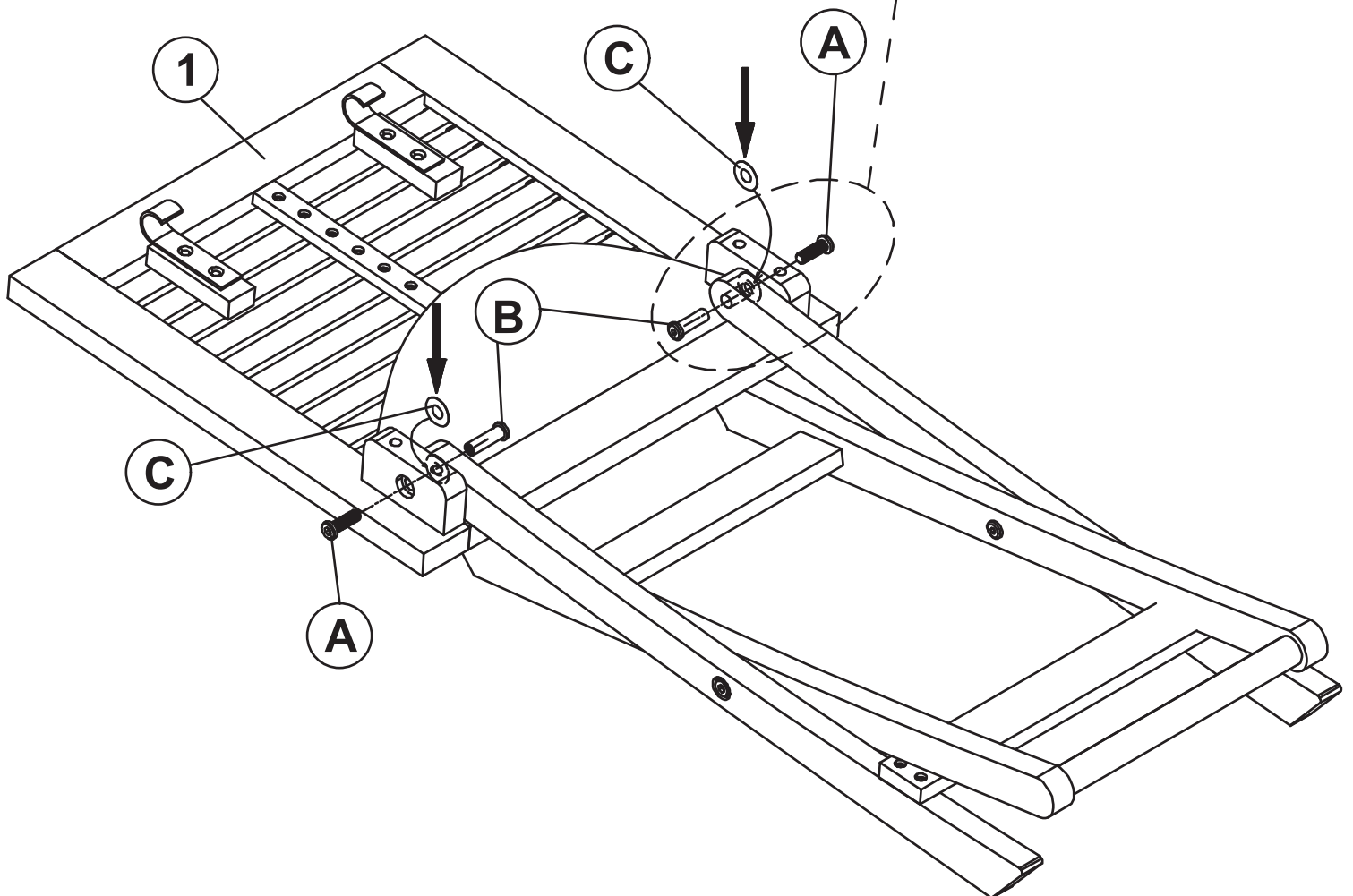

# **Limited Warranty and Care Instructions**

## **LIMITED ONE YEAR WARRANTY (NON-TRANSFERABLE)**

This product is covered under United General Supply's (UGS) one (1) year limited warranty. To the original purchaser of this piece of furniture, cooler or accessory; UGS warrants that it will be free from defects in material and workmanship for up to one year from the date of purchase under normal use and proper care.

Replacement of defective or missing parts will be sent at no charge to the customer for a period of 30 days from the date of purchase. UGS will no longer be responsible for missing parts or hardware 30 days after date of purchase. Freight, packaging, labor or material charges to and from our customer service center is not covered under the warranty and is therefore the customer's responsibility.

The limited warranty does not cover this piece of furniture, cooler or accessory for commercial purposes, abusive use, damage by modification, freeze damage, rust, fading and issues caused by improper care.

For minor defects or missing parts/hardware, please contact customer service immediately upon purchase. Please do not return product to the store unless the product is irreparable. A customer service agent may help determine whether the damage is reparable and will provide further instructions.

For returns and refunds, please refer to your local store return policy with proof of purchase.

Proof of purchase (dated register receipt) will be required for warranty claims.

## **PROPER CARE INSTRUCTIONS**

If left untreated, wood will naturally weather. During long periods of non-use, store furniture or cooler in covered and dry place. For the least maintenance, place your furniture, cooler, or accessory under a covered area.

To preserve and maintain the original finish of this cooler/furniture, a natural tung/linseed/Danish oil (with stain), which can be found at your local hardware store, should be applied. Please note the cooler/furniture has been stained and oiled before being packaged. If the wood is not maintained, the wood will naturally grey in color.

Remove the cooler/furniture completely from sunlight prior to applying oil. Apply generously and remove any excess oil with cloth. Frequency of the application of oil depends on exposure to the extremities of the outdoors.

Customer Service may be reached Monday through Friday from 9:00a.m. to 5:00p.m. CST.

**HELP@UGSCO.COM OR 1-877-87LEIGH (53444)**



DISTRIBUTED BY:  
UNITED GENERAL SUPPLY CO., INC.  
HOUSTON, TX 77036

**www.LeighCountry.com**