

# OWNER'S MANUAL

## Model: LG-30-3N-TRL (5302950)

### (30 Gallon Lawn & Garden Trailer Sprayer)

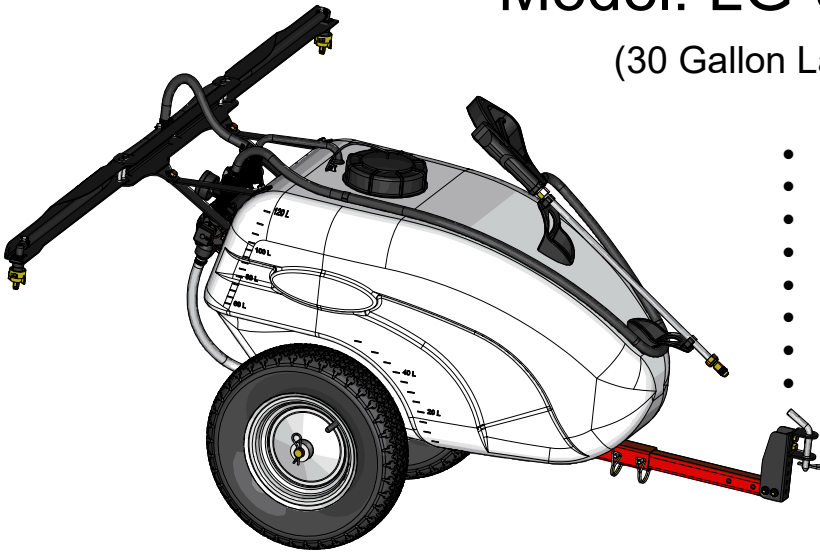

#### Technical Specifications

- 30 Gal. Corrosion-Resistant Polyethylene Tank
- 12 Volt Diaphragm Pump, 2.4 GPM - 60 PSI
- 20 Ft. Handgun Hose
- 25 Ft. max. vertical throw, 35 Ft. horizontal throw
- 3-Nozzle Break-Away Boom Assembly
- Corrosion-Resistant Nylon Nozzles
- Check Valve Strainers, 50 Mesh, 5 PSI
- Easy access drainage port (Complete Drain Out)
  - Front forward gun and hose wrap for easier access from transport vehicle
  - Heavy Duty 16" tires
  - Wide Axle
  - Streamlined tank design for compact storage and shorter turning radius

#### General Information

Thank you for purchasing this product. The purpose of this manual is to assist you in operating and maintaining your lawn & garden Trailer sprayer.



**WARNING:** To reduce the risk of injury, the user must read and understand the operator's manual before using this product.



**WARNING:** Cancer and Reproductive Harm  
[www.P65Warnings.ca.gov](http://www.P65Warnings.ca.gov)



**NOTE:** Maximum Speed - 5 MPH  
Refer to vehicle's manual for towing instructions

#### Assembly Instructions

- Make sure the contents of the sprayers carton match the items shown on page 2 of the manual.
- Follow the steps on pages 3 & 4 to properly assemble the sprayer.

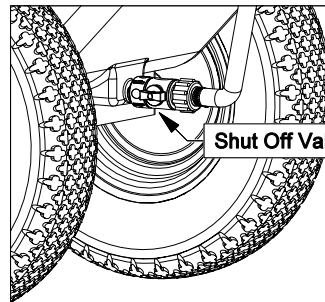

#### IMPORTANT:

This sprayer comes with an On/Off (shut-off) valve located at the inlet location of the tank, towards the underside. You must make sure the valve is in the "open" position before using your sprayer.

BEFORE RETURNING THIS PRODUCT  
FOR ANY REASON, PLEASE CALL

**1-800-831-0027**

MONDAY-FRIDAY, 8:00 AM TO 5:00 PM CST

If you should have a question or experience a problem with your Fimco Industries Product: Visit our website @ [www.fimcoindustries.com](http://www.fimcoindustries.com) or call the Toll free number above. Our technical support representatives will be happy to help you. In most cases a customer service rep. can resolve the problem over the phone.

To obtain prompt, efficient service, always remember to give the following information....

- Correct Part Description and/or part number
- Model number and Serial Number

Part descriptions and numbers can be obtained from the illustrated parts list section(s) of this manual.

**Retain a copy of your receipt for your unit, as it will be required to validate any warranty service.**

**Warranted against manufacturer or workmanship defects from date of purchase with copy of receipt:**



**Homeowner Usage: Sprayer-One Year and Pump-Two Years.**

**Commercial Usage: Sprayer and Pump-90 Days.**



[www.fimcoindustries.com](http://www.fimcoindustries.com)

1000 FIMCO Lane, P.O. Box 1700, North Sioux City, SD 57049  
Toll Free Phone: 800-831-0027 : Toll Free Fax: 800-494-0440

[5195129

(02/19)]

# Contents of your sprayer's carton (LG-30-3N-TRL)

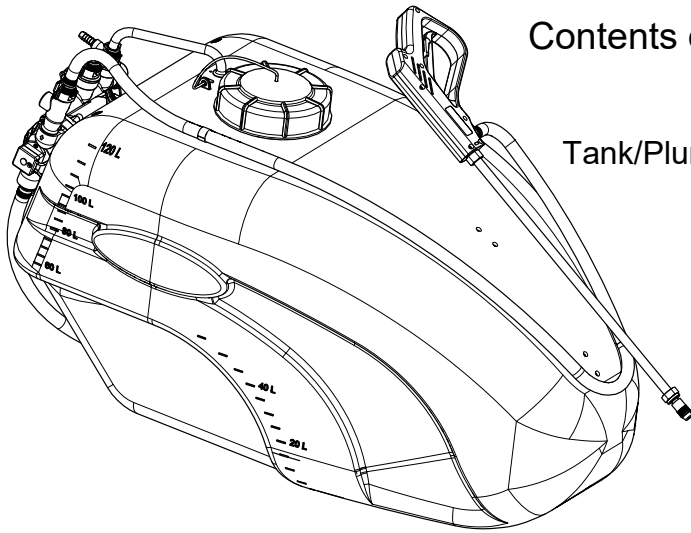

Tank/Plumbing Pre-Assembly



Owner's Manual

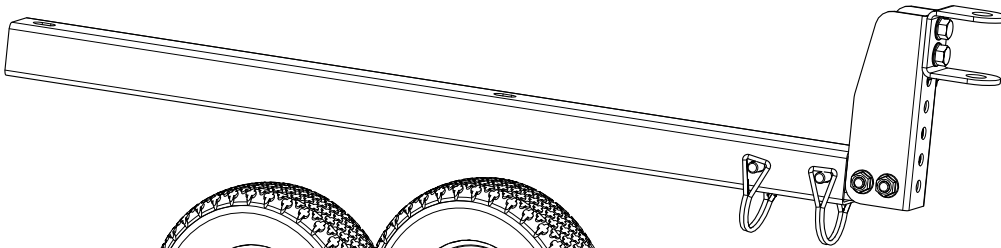

Tongue Assembly

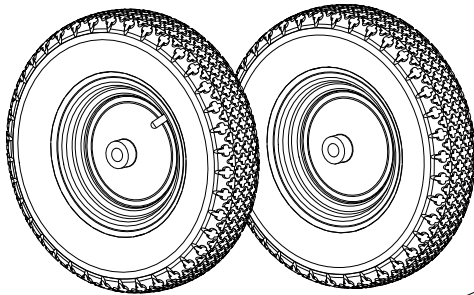

Tires

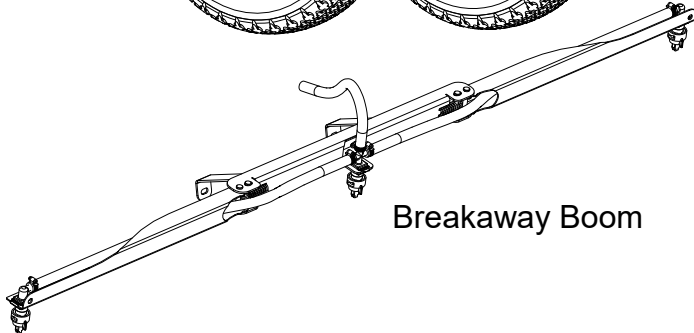

Breakaway Boom

## Contents of Parts Bag (#5281138)

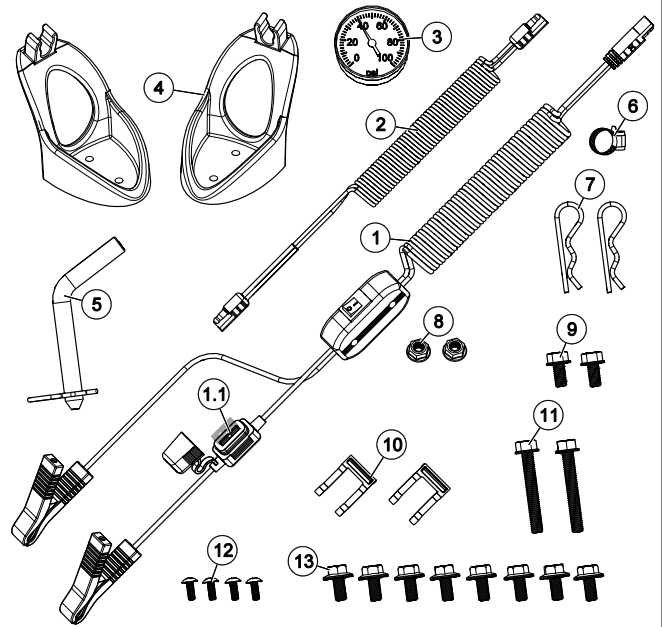

Ref. #	Part #	Description	Qty
1	5278114	Lead Wire Assembly w/15A Fuse (96" Long)	1
1.1	5157238	15 Amp Regular Blade Fuse	1
2	5273212	5 Ft. Extension Cable	1
3	5167097	2" Dry 100# Back Mount Gauge	1
4	5133276	30 Gallon Hose Wrap	2
5	5101202	Bent Clevis Pin (1/2" Dia.) w/Clip	1
6	5051144	Hose Clamp, 3/8"	1
7	5101065	#211 Hitch Pin Clip (Zinc Plated)	2
8	5006307	5/16-18nc Hex Flanged Whiz Nut Gr. 5	2
9	5034634	H.H.C.S. Flanged 5/16"-18nc x 5/8" Long	2
10	5053110	Plastic Retaining Clip (14 & 16 Ga.)	2
11	5034641	H.H.C.S. Flanged 5/16"-18nc x 2 1/4" Long	2
12	5117234	#10-24 x 1/2" Phillips Truss Head Machine Screw	4
13	5034531	5/16"-18 x 5/8" Flange Lock Screw	8

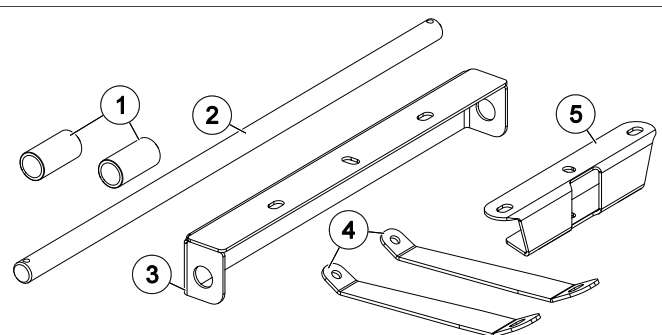

Bracket Kit

Ref. #	Part #	Description	Qty
1	5127226	3/4" x 2" Axle Spacer	2
2	5101351	Axle 3/4" x 25-13/16"	1
3	5095371	Axle Mount	1
4	5037868	Boom Top Strap	2
5	5095373	Tank Support	1

Your tank comes pre-assembled with the pump, manifold, bypass, intake assembly, lid w/lanyard, handgun, handgun hose, handgun hose quick connect and loom clamp already attached.

To assemble the tongue and frame to the tank. Locate the (4) 5/16" x 5/8" Flange Lock Screws, (2) 5/16" x 2-1/4" Flanged bolts, tank support, axle support and the tongue assembly.

Turn the tank upside down.

Detail A: Loosely attach the tank support and axle support with (4) lock screws. Just start the bolts, do not tighten on either support.

Detail B: Slide the tongue assembly into place and using the (2) flanged bolts, attach to the tank and tighten. Do Not Overtighten.

Then tighten the (4) lock screws from Detail A. Do Not Overtighten.

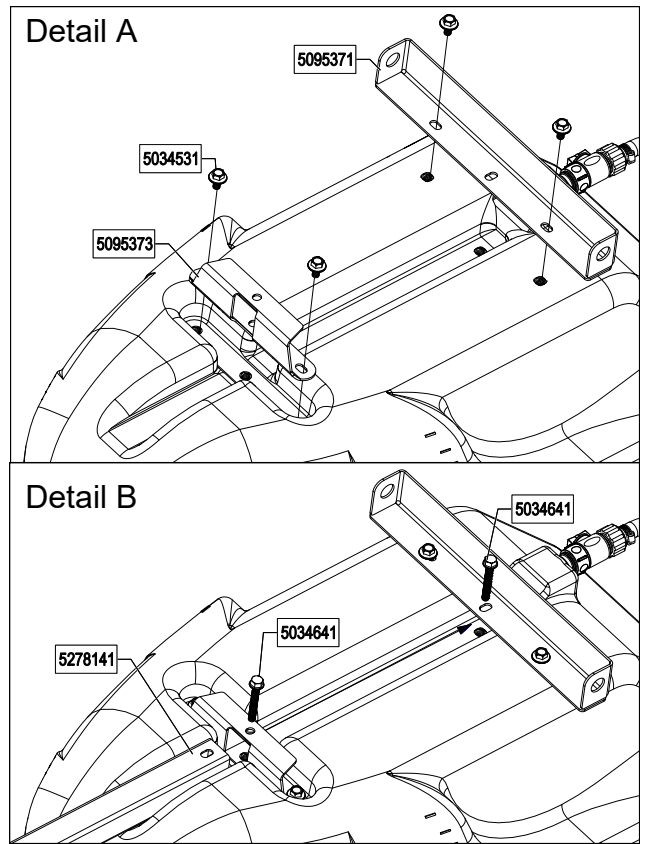

Locate the axle, spacers and (2) wheels from the carton.

Remove the (2) Hair Pin Clips from the parts bag.

Slide the axle through the hole in one side of the axle mount and through the corresponding hole on the other side. Then slide the spacers onto the axle.

Slide the wheels over the axle, making sure the valve stems are facing outward.

Retain the wheels on the axle with the hair pin clips. Place the pins through the holes at the end of the axle.

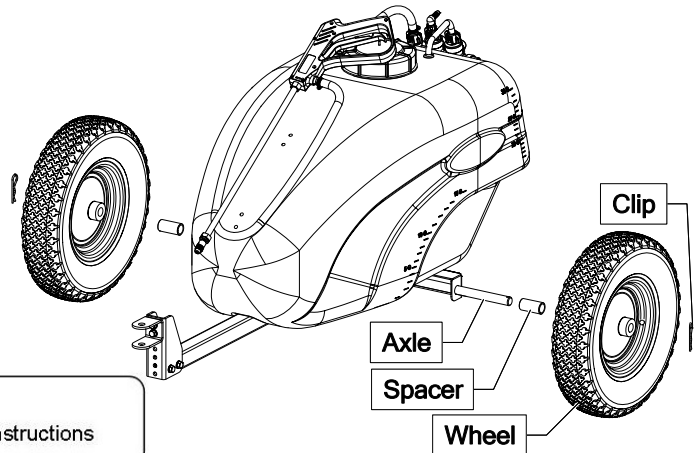

**!** **NOTE:** Maximum Speed - 5 MPH  
Refer to vehicle's manual for towing instructions

The telescoping Tongue Assembly comes fully assembled.

Remove D-Clip pins to slide tongue in and out for usage or storage. Replace D-Clip pins to retain the tongue in the position

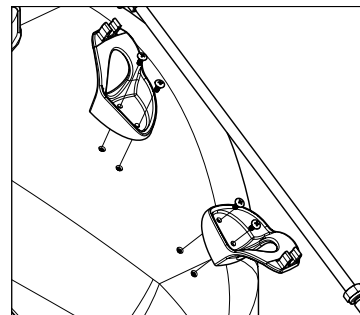
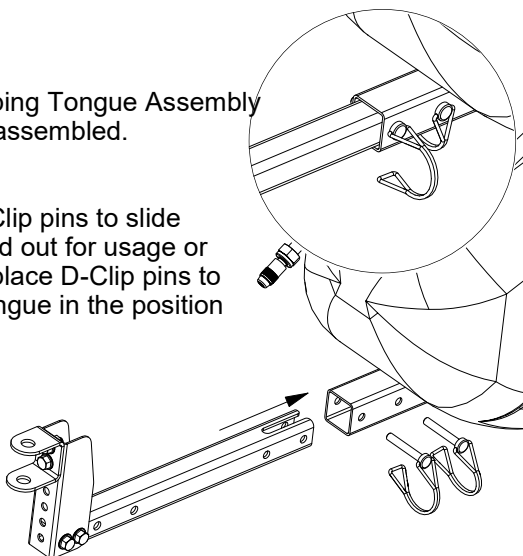

• A phillips head screwdriver is required for this step

Turn the trailer right side up. Locate the (4) #10 x 1/2" Screws and the (2) Hose Wraps from the parts bag.

Place a screw through the holes in the hose wrap and bring it up to the tank. Use the phillips head screwdriver to secure the holders in place. Tighten so the holders are secure.

**\*\*Do Not Over-Tighten\*\***

Wrap the hose and clip in the handgun. Do not use excessive force when placing the handgun into the clips, as this could cause breakage.

Break-Away Boom Assembly is partially preassembled. Follow the directions below to mount to your tank.

**Detail A:**

Locate the (2) Boom Top Straps and then in the parts bag, locate (2) 5/16-18 x 5/8" Flanged Lock Screws.

Attach the Boom Top Straps to the tank, using the two screws.  
**DO NOT TIGHTEN**

**Detail B:**

Locate the Boom Assembly and then in the parts bag, locate (2) 5/16-18 x 5/8" Flanged Lock Screws.

Attach the Boom Assembly to the tank, using the two screws.  
**DO NOT TIGHTEN**

**Detail C:**

Locate in the parts bag (2) 5/16-18 x 5/8" Flanged Bolts and (2) Whiz Nuts.

Attach the Boom Top Straps to the Boom Assembly using the two bolts and whiz nuts.

\*\*\*\* Tighten all Bolts from Details A, B & C \*\*\*\*  
\*\*\*\* DO NOT OVERTIGHTEN \*\*\*\*

**Detail D:**

Attach the nozzle onto the end of the boom arm and secure with poly spring clip. Repeat for other side.

**Detail E:**

Slide hose clamp onto the end of the 8" Feeder Hose and with a twisting motion, attach to the 90° HB Elbow on the manifold.

The boom is now installed.

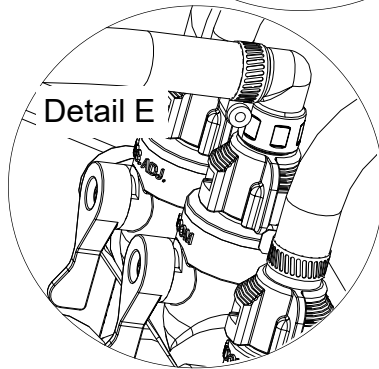
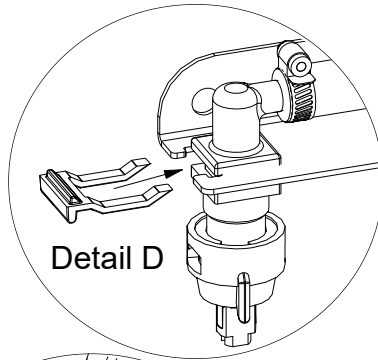
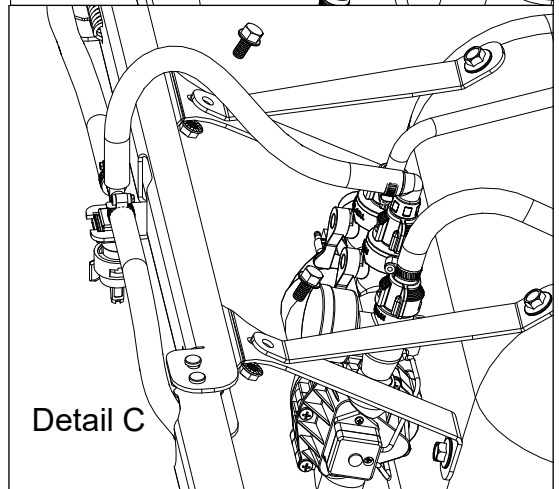
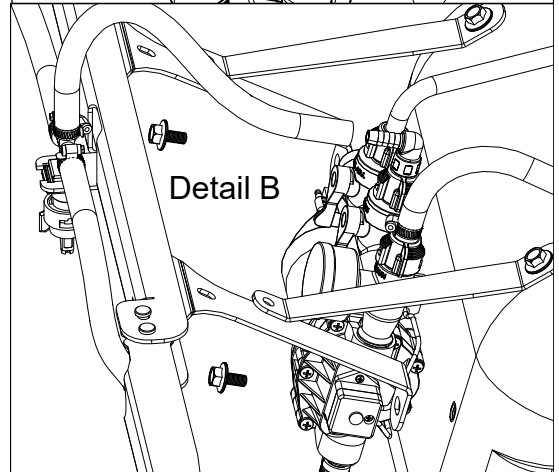
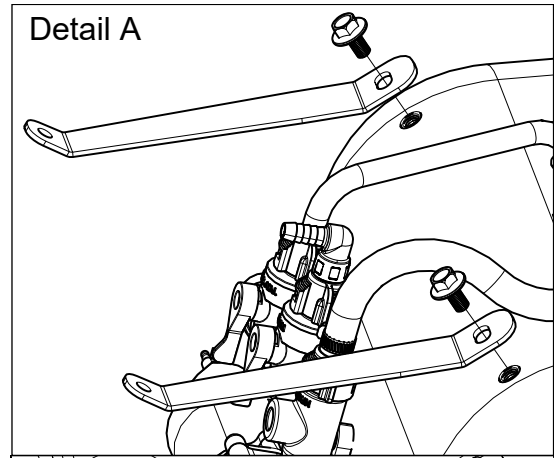

Final Steps:

Locate the Pressure Gauge in the parts bag and thread into the open port on the manifold.

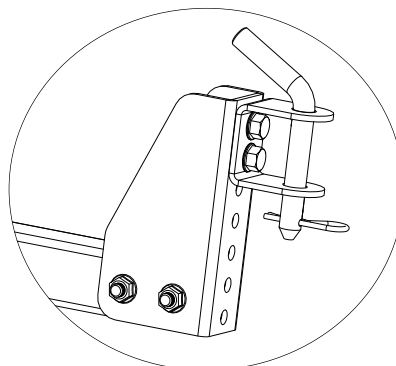

Locate the Bent Clevis Pin in the parts bag and place in the hole on the hitch.

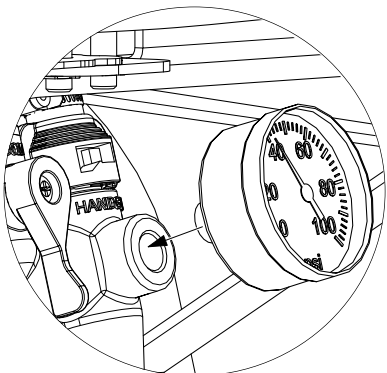

\*\*\* The Sprayer should now be ready for use \*\*\*

**IMPORTANT:** Remove tank lid and be sure the tank is clean and free of any foreign material. Rinse tank out of any tank residue before filling with water to test.

### Testing the Sprayer

**NOTE:**

It is VERY important for you to test your sprayer with plain water before actual spraying is attempted. This will enable you to check the sprayer for leaks without the possibility of losing any expensive chemicals.

Fill the tank about 1/2 full with plain water and drive to the starting place for spraying.

When you are ready to spray, turn the boom valve to the "on" position (Detail A). This will start solution spraying from the tips of the boom. The pressure will decrease slightly when the boom is spraying.

Adjust the pressure by turning the "ON/OFF" valve lever on the bypass line valve (Detail B). Make sure your pattern is sufficient. You may down-pressure the system by 'bypassing' solution back into the tank. This is achieved by opening the bypass valve. Regulating pressure is done in this manner.

Read the operating instructions and initially begin spraying by closing the 'Pressure Adjust' valve and opening the boom line valve (Detail A). This will enable the air in the line to be eliminated (purged) through all the tips, while building pressure. When everything tests all right (no leaks and good pressure), add the desired chemicals to the mixture and water combination and start your spraying operation. Adjust the pressure and spray as you did in the testing procedure.

Conditions of weather and terrain must be considered when setting the sprayer. Do not spray on windy days. Protective clothing must be worn in some cases.

**Be sure to read the chemical label(s) before application!**

### Operation

The pumping system draws solution from the tank, through the strainer and to the pump. The pump forces the solution under pressure to the handgun or boom nozzles.

Connect the lead wire to a fully charged 12 volt battery. You may use either a stand-alone battery or the battery on your towing vehicle. Connect to the positive (red) terminal first, then connect to the negative (black) terminal. Then connect the end of the lead wire to the end of the pump. When disconnecting, disconnect the end of the pump wire from the lead wire, then disconnect the negative (black) connection and finally the positive (red) connection. The lead wire has an On/Off switch to activate the pump. "-" is on and "O" is off.

Fill the tank part way with water and then add the desired amount of chemical to be sprayed. Finish filling tank to proper level. Turn the pump on and by depressing the "-" side of the rocker switch. The pump is equipped with a pressure switch that is pre-set at the factory to shut the pump off when all discharges are closed.

The pump will turn back on when one of the following actions occurs:

- ◆ Handgun lever is squeezed to spray the handgun.
- ◆ Boom valve is opened to broadcast spray with the boom.
- ◆ Bypass valve is opened to re-circulate solution back into the tank.

When spraying with either the boom or the handgun, pressure may be reduced by slowly opening the bypass valve until desired pressure is achieved. Opening the valve decreases pressure, closing the valve increases pressure. When spraying with the boom, the proper method to set the pressure is to open the boom valve completely and if a lower pressure is desired, then slowly open the bypass valve until that pressure is obtained.

For the safest and most efficient chemical application, you will need to calibrate your sprayer using the tip and speed charts. Once you have determined the proper speed and pressure settings, you will need to consult your chemical label for the amount of chemical to be added to the tank. Read the entire label. Use only according to label directions.

### Calibration

Chemical labels may show application rates in gallons per acre, gallons per 1000 square feet or gallons per 100 square feet. You will note that the tip chart shows 2 of these rating systems. Once you know how much you are going to spray, then determine (from the tip chart) the spraying pressure (PSI), and the spraying speed (MPH).

Determining the proper speed of the pulling vehicle can be done by marking off 100, 200 & 300 feet. The speed chart indicates the number of seconds it takes to travel the distances. Set the throttle and with a running start, travel the distances. Adjust the throttle until you travel the distances in the number of seconds indicated by the speed chart. Once you have reached the throttle setting needed, mark the throttle location so you can stop and go again, returning to the same speed.

Add water and proper amount of chemical to the tank and drive to the starting place for spraying.

Manifold Valves CLOSED

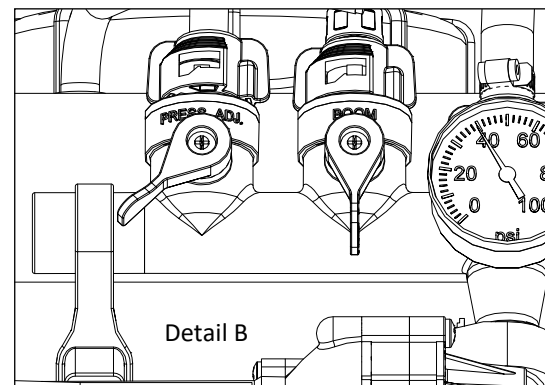
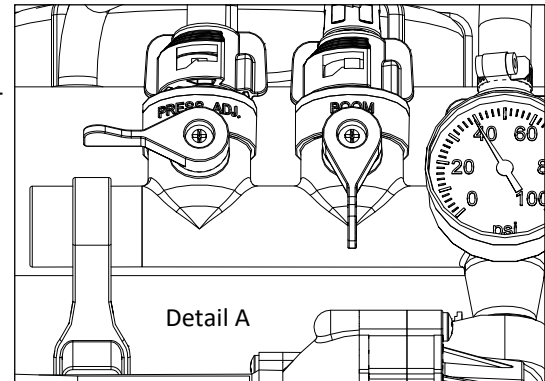
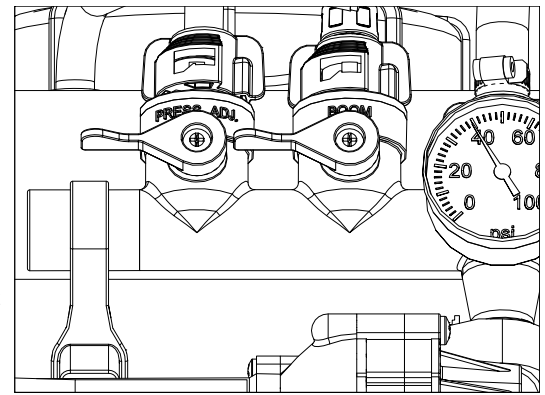



Speed Chart			
Speed in M.P.H. (Miles Per Hour)	Time Required in seconds		
	100 Ft.	200 Ft.	300 Ft.
1.0	68 sec.	136 sec.	205 sec.
2.0	34	68	102
3.0	23	45	68
4.0	17	34	51
5.0	14	27	41
6.0	11	23	34
7.0	9.7	19	29
8.0	8.5	17	26
9.0	7.6	15	23
10.0	6.8	14	20

Spray Tip Rate Chart (30" Spacing)							
Tip No.	Pressure (psi)	Capacity (GPM)	Gal. Per Acre - Based on Water				
			1 MPH	2 MPH	3 MPH	4 MPH	5 MPH
AIXR11002VP	15	.12	23.50	11.70	7.80	5.90	4.70
	20	.14	27.50	13.70	9.10	6.90	5.50
	30	.17	33.30	16.60	11.10	8.30	6.70
	40	.20	39.30	19.70	13.10	9.80	7.90
Tip No.	Pressure (psi)	Capacity (GPM)	Gal. Per 1000 Sq. Ft. - Based on Water				
			1 MPH	2 MPH	3 MPH	4 MPH	5 MPH
AIXR11002VP	15	.12	.54	.27	.18	.13	.11
	20	.14	.64	.32	.21	.16	.13
	30	.17	.76	.38	.26	.19	.15
	40	.20	.90	.45	.30	.22	.18

### Using the Boom Nozzles

Four things must be considered before spraying with the boom.

1. How much chemical must be mixed in the tank.
  2. Rate of spray (gallons per acre to be sprayed).
  3. What pressure (p.s.i.) will be used.
  4. Speed traveled (mph) while spraying.
- \* Refer to the chemical label to determine your chemical mixture
  - \* See the tip chart to determine the pressure to be used. The chart will also show the speed used when spraying.
  - \* Start the pump and open the valve to the boom nozzles.
  - \* Check the spray pattern. Usually you can see the coverage better on a solid concrete surface, such as a driveway.

### Maintenance During/After Spraying

Periodically check the strainer and clean the screen on your intake line.

Proper care and maintenance will prolong the life of your sprayer.

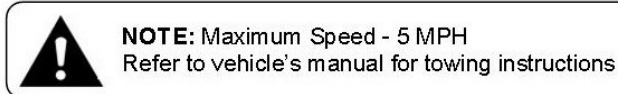

After use, drain the tank and store or dispose of chemical properly. Fill the sprayer half way with clean water. Start the pump and allow the water to pump through the entire plumbing system and nozzles. Drain and then refill half full, add the recommended amount of a good quality tank cleaner, such as FIMCO Tank Neutralizer and Cleaner. (If no tank cleaner is available, you may substitute dish soap for this step, about 1-2 oz. per gallon). Turn pump on and circulate through system for 15 minutes and then spray out through boom and handgun nozzles. Refill sprayer half way with clean water and repeat. Follow the chemical manufacturer's disposal instructions of all wash or rinsing water.

If boom or handgun nozzles need cleaning, remove them from the sprayer and soak in warm soapy water. Clean with a soft bristled brush or toothpick if necessary. Never use a metal object. Even the slightest damage can change the flow rate and spray distribution. Water rinse and dry the tips before storing.

**WARNING:** Some chemicals will damage the pump valves if allowed to soak untreated for a length of time! ALWAYS flush the pump as instructed after each use. DO NOT allow chemicals to sit in the pump for extended times of idleness. Follow the chemical manufacturer's instructions on disposal of all waste water from the sprayer.

### Winter Storage

Prepare the sprayer for end-of-season storage by running RV antifreeze through the system. This will keep internal parts lubricated, protect against corrosion and keep the unit from freezing. *Note: RV antifreeze is non-toxic and biodegradable and generally safer for the environment than automotive antifreeze.*

Before storing your sprayer for winter or long term storage, thoroughly clean and drain it as much as possible. Then pour enough pink RV antifreeze into the tank so that when the pump is turned on you can pump the antifreeze throughout the entire plumbing system, including the bypass. Make sure to operate the boom and handgun until you see pink fluid spraying from the nozzles. Leave any remaining antifreeze in the tank. Before your next usage, rinse the antifreeze from the sprayer with clean water.

It is nearly impossible to drain all of the water from the sprayer and any trapped water can freeze in cold weather and damage parts of the sprayer. Pumping the antifreeze through the system will displace the water and help prevent this damage.

Removing from storage: drain the antifreeze. Fill the tank with fresh water and run through the system. Dispose of antifreeze and flush water properly.

**STOP WARNING STOP**  
 DO NOT USE PUMP IN AN EXPLOSIVE ENVIRONMENT. DO NOT USE TO PUMP FLAMMABLE/COMBUSTIBLE FLUIDS, GASOLINE, KEROSENE, FUEL, OIL, ETC.

**HIGH FLO**  
**HIGH PERFORMANCE**

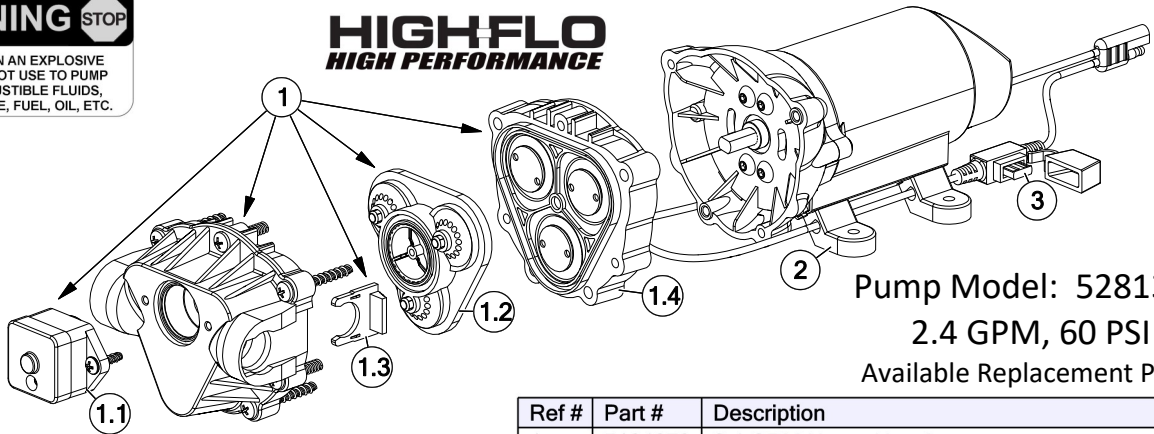

**Pump Model: 5281371**  
**2.4 GPM, 60 PSI**  
 Available Replacement Parts

**Replacement Pump: 5151087**

- Includes:
- 1/2" MNPT Port Kit Fitting #5168832
  - 1/2" Hose Barb Port Kit Fitting #5168833
  - 3/8" Hose Barb Port Kit Fitting #5168836

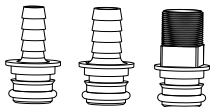

Ref #	Part #	Description	Qty
1	5164273	2.4 GPM Upper Housing	1
1.1	5157202	60 PSI Pressure Switch Assembly	1
1.2	5143544	Check Valve Assembly	1
1.3	5051162	Pump Slide Clips (Pkg/2)	1
1.4	5063270	2.4 GPM Diaphragm /Piston/Cam/Bearing Kit	1
2	5095202	Pump Mount Feet (4 Pack)	1
3	5164274	10 Amp 'Mini Blade' Fuse	1

**DO**

- Clean and rinse your pump after each use with Fimco Tank Neutralizer
- Winterize your pump or sprayer by rinsing, draining and running RV Antifreeze through it before storing for the winter.
- Use clean water for your spray mixture
- Store inside a building when not in use.

**DON'T**

- Use to pump bleach.
- Use to pump petroleum products such as diesel fuel, gasoline or kerosene
- Leave your pump sit with spray mixture in it for extended periods
- Use dirty or unfiltered water for spraying

**CAUTION**  
**PRESSURE SWITCH OPERATION**  
 Pressure switch is pre-set at the factory. Improper adjustment of the pressure switch, may cause severe overload or premature failure. If the pump is subjected to rapid cycling during normal operation, or infrequent periods, damage may occur.

**Troubleshooting the Pump:**

Motor does not run:

- Check for loose wiring connection(s).
- Make sure the 'ON/OFF' switch in the lead wire assembly is in the 'ON' position. 'I' is the 'ON' position and 'O' is the 'OFF' position.
- Check for defective pressure switch. Make sure you are connected to a good 12 volt power source. Make sure any on/off switches are in the 'on' position. Remove the cap to the pressure switch. Pull both red wires off of their terminals, and touch the two ends together. If your pump runs when you do this, your pressure switch will need to be replaced.
- Check the fuse.
- Check for low voltage at the power supply.

Pump does not prime:

- Check for air leaks in supply line.
- Check for debris in the check valve assembly.
- Check for defective check valve.
- Check for clogged strainer/filter.
- Check for cracks in the pump housing.
- Check for empty product supply.

Low Pressure/Low Flow:

- Check for leaks in the discharge line.
- Check for restriction in the discharge line.
- Check for debris in nozzle orifice.
- Check for clogged strainer.
- Check for proper voltage—try another 12-volt battery.

Pulsating flow (surging):

- Low flow may cause pump to surge.
- Spray wand is adjusted for a small or fine spray pattern.
- Slightly open bypass (if applicable) to overcome.
- If needed, pressure switch may need to be adjusted—adjust a quarter turn at a time clockwise until surging stops.
- Check for defective pressure switch.
- Check for leaks in the discharge line.
- Check for restriction in the discharge line.
- Check for debris in nozzle orifice.
- Discharge hose may be too long.
- Check for clogged strainer.

Motor continues to run after discharge is shut off:

- Check for empty product supply.
- Check for open bypass valve. (if equipped)
- Check for low voltage.
- Check for leak in discharge line.
- Check for defective pressure switch.
- System has leaks.

Fuse blows:

- Excessive voltage.
- Improper adjustment of pressure switch.
- Damaged or defective wiring harness.
- Half-moon & counterweight are sticking.
- Defective pressure switch.

**Checking the Pressure Switch:**

If your motor is not running and you've checked the following: for loose wiring connections, fuse, the switch on the lead wire was "ON" and made sure you were connected to a fully charged battery and everything is fine, but the motor won't run, then it's time to check to see if the pressure switch is bad.

- Remove the cover off the 1" square box (pressure switch) on the head of the pump, the cover is held on by one phillips-head screw. This will expose the two red wires.
- With the pump connected to a good 12 volt power source and everything on.
- Slip the two red wires off the terminals and touch them together.

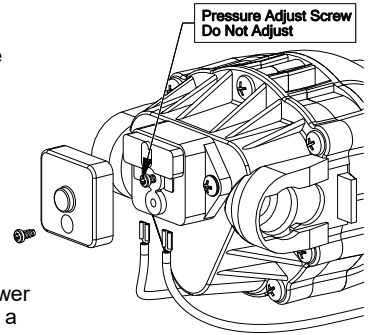

If the motor runs, it means the pressure switch is bad and needs to be replaced.

If it still doesn't run, try bypassing the switch in the lead wire or using another lead wire. Even if a tester shows power to the pressure switch, it still could be the switch in the wire that is causing the problem. If still not responsive, use a voltmeter or electrical tester to make sure you are getting power to the head of the pump, as it could possibly be something in one of the wires or even the lead wire assembly may need to be replaced.

**Warning:** It is NOT recommended to run the pump this way, as the pump will continue to run and not shut off.

This could result in blown hoses when all discharges are closed. Also, this could result in premature failure of the pump completely.

**Cleaning the Check Valve:**

If you're experiencing little to no pressure or the pump is not priming and you've checked your filter screen and it's clean, and you've gone through the other trouble shooting tips, you may need to clean the check valve.

- Remove the head of the pump, which is held on by 7 screws.
- The first piece inside the head of the pump is called a check valve, it's the part responsible for building up pressure and pumping water/solution through the lines.
- Clean the check valve under hot, soapy water (such as a good grade dish soap).
- Give it a very light scrubbing with something like an old toothbrush, something with soft bristles.
- Then let it soak for about an hour or so in the hot soapy solution and replace in the pump and reassemble the pump.

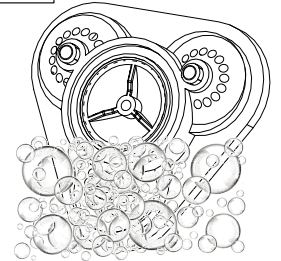
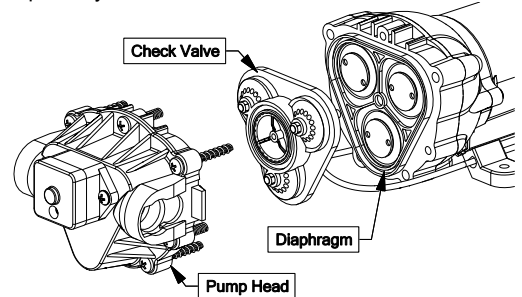

Most times this will restore most, if not all of the prime of a pump.

If you're still having issues with pressure after this step, it would be recommended to replace this part.

Troubleshooting	
Pump will not run:	Check for loose wiring
	Make sure the ON/OFF switch is on
	Check the fuse
	Check for defective pressure switch
Low Pressure/Low Flow:	Check for a clogged strainer
	Check for proper voltage Try another 12-Volt battery
	Check for worn or dirty check valve
Pump surges:	Low flow may cause pump to surge
	Spray wand is adjusted for a small or fine spray pattern
	Slightly open bypass (if applicable) to overcome
	If needed, pressure switch may need to be adjusted Quarter turn at a time clockwise until surging stops
Pump continues to run:	Bypass is not completely closed
	System has leaks
	Check for worn or dirty check valve
Fuse blows:	Excessive voltage
	Improper adjustment of pressure switch
	Damaged or defective wiring harness
	Defective pressure switch



Exploded View/  
Parts List:  
LG-30-3N-TRL  
(5302950)

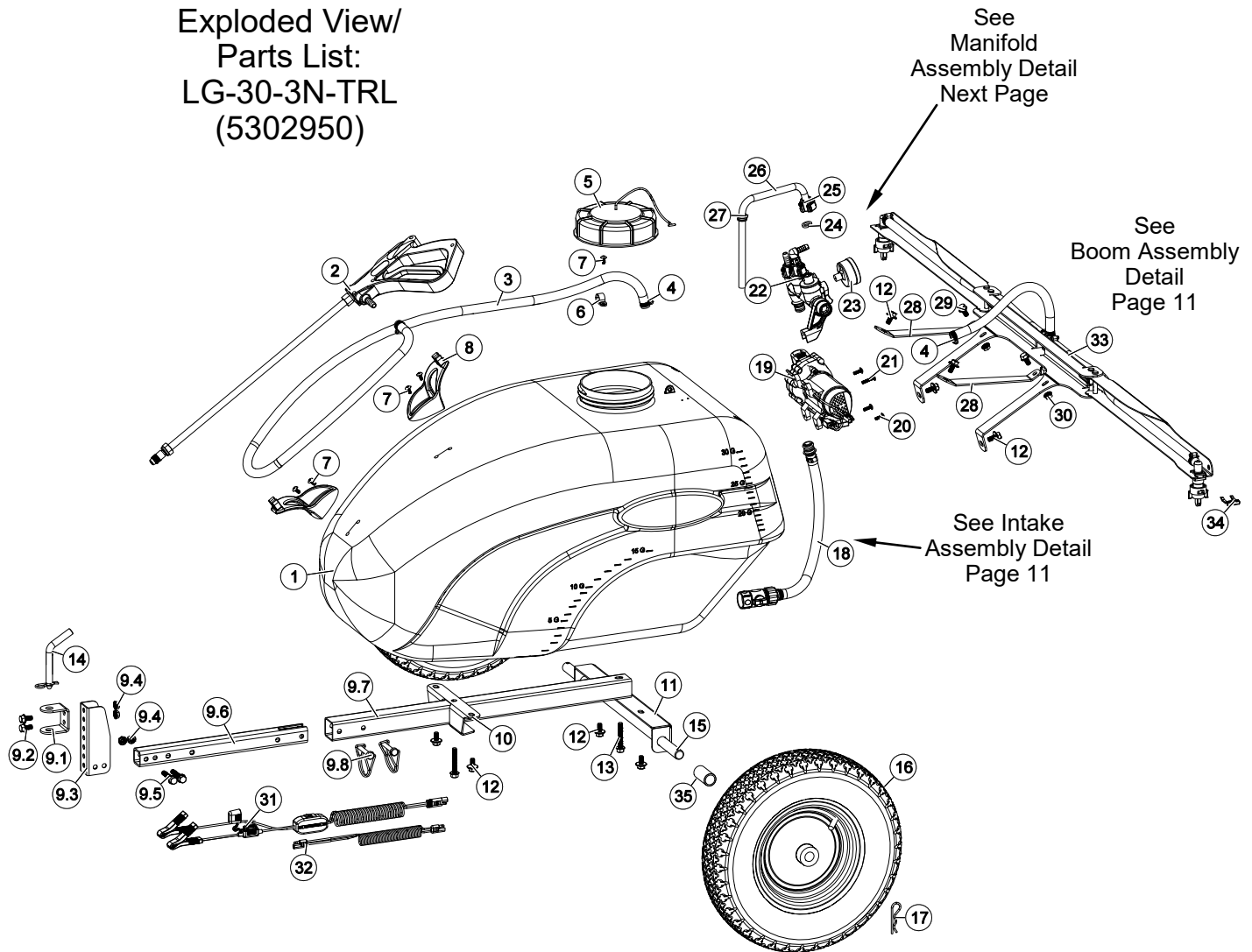

Ref. #	Part #	Description	Qty
1	5169321	30 Gallon Trailer Tank	1
2	5273959	Deluxe Pistol-Grip Handgun w/X-26 Tip	1
2.1	5018331	Brass Handgun Tip (X-26)	1
3	5020584	Hose, 3/8"-1 Brd. x 20 Ft.	1
4	5051144	Hose Clamp, 3/8"	3
5	5058188	Tank Lid w/Lanyard	1
6	5051122	5/8" Black Nylon Loom Cable Clamp	1
7	5117234	#10-24 x 1/2" Phillips Truss Head Mach. Screw	5
8	5133276	Hose Wrap	2
9	5281065	In Tube Telescoping Tongue	1
9.1	5038854	Hitch	1
9.2	5117323	H.H.C.S. Flanged 5/16"-18nc x 3/4"	2
9.3	5038853	Hitch Bracket	1
9.4	5006307	5/16-18nc Hex Flanged Whiz Nut Gr. 5	4
9.5	5034639	H.H.C.S. Flanged 5/16"-18nc x 1 3/4"	2
9.6	5100934	Telescoping Trailer Tongue	1
9.7	5100935	Telescoping Trailer Tongue Frame	1
9.8	5101260	5/16" x 1-3/4" Lynch Pin	2
10	5095373	Tank Support	1
11	5095371	Axle Mount	1
12	5034531	5/16"-18 x 5/8" Flange Lock Screw	8
13	5034641	H.H.C.S. Flanged 5/16"-18nc x 2-1/4"	2
14	5101202	Bent Clevis Pin (1/2" Dia.)	1
15	5101351	Axle 3/4" x 25-13/16"	1
16	5021090	Tire, 4.80 x 8 (2-Ply)	2
16.1	5031141	3/4" Wheel Ball Bearing	2
17	5101065	#211 Hitch Pin Clip (Zinc Plated)	2
18	5278143	Intake Assembly	1
18.1	5143419	Swivel Shut-Off	1
18.2	5116242	Strainer, 1" Filter Washer	1

Ref. #	Part #	Description	Qty
18.3	5149035	Poly Swivel, 1/2" Hose Barb	1
18.4	5006209	Poly Knurled Swivel Nut, 3/4" FGHT	1
18.5	5051114	Hose Clamp, 1/2"	2
18.6	5020566	Hose 1/2" Polyspring X 12.75"	1
18.7	5168833	Port Kit Fitting, 1/2" Hose Barb	1
19	5281371	High-Flo High Performance 2.4 GPM Pump, 60 PSI	1
20	5117167	#10-24 x 5/8" Phillips Truss Head Mach. Screw	3
21	5117168	#10-24 x 1" Phillips Truss Head Mach. Screw	1
22	5302352	Quick Connect Manifold Assembly	1
22.1	5302347	Quick Connect Manifold Assembly	1
22.2	5143422	QC Manifold - Support Bracket	1
22.3	5302802	QC Manifold 3/8 Swivel 90° Elbow Assembly	1
22.4	5143430	Flat Washer - Hose Barb Seal	1
22.5	5143431	QC Manifold - 3/8" Hose Barb - Straight	1
22.6	5143429	QC Manifold - QC Quarter Turn Cap	1
23	5167097	2" Dry 100# Back Mount Gauge	1
24	5143430	Flat Washer - Hose Barb Seal	1
25	5143429	QC Manifold - QC Quarter Turn Cap	1
26	5149152	Rigid By-Pass Tube	1
27	5075018	Grommet, 1/2" I.D.	1
28	5037868	Boom Top Strap	2
29	5034634	H.H.C.S. Flanged 5/16"-18nc x 5/8"	2
30	5006307	5/16-18nc Hex Flanged Whiz Nut Gr. 5	2
31	5278114	Lead Wire Assembly (96" Long)	1
31.1	5157238	15 Amp Regular Blade Fuse	1
32	5273212	5 Ft. Extension Cable	1
33	5281064	3-Nozzle Boom	1
34	5053110	Plastic Retaining Clip (14 & 16 Ga.)	2
35	5127226	3/4" x 2" Axle Spacer	2

## Boom Detail Exploded View/Parts List

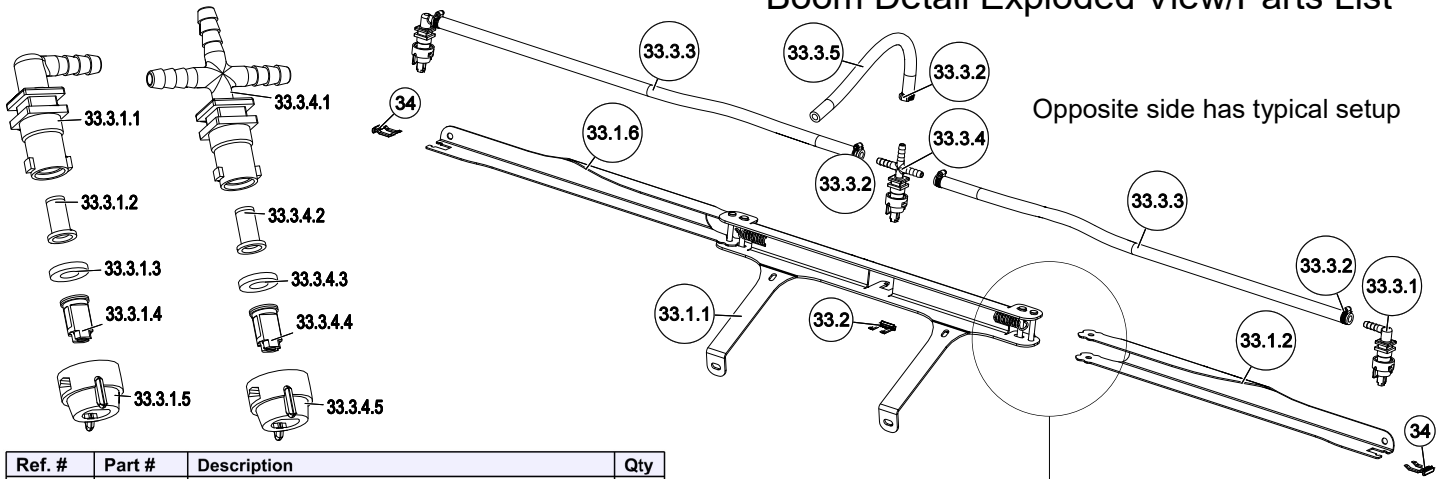

Ref. #	Part #	Description	Qty
33	5281064	3-Nozzle Boom Assembly	1
33.1	5281006	3-Nozzle Boom SubAssembly	1
33.1.1	5037926	AIXR Boom Lower Support	1
33.1.2	5030925	AIXR LH Boom	1
33.1.3	5019755	Boom Detent Spring	2
33.1.4	5101366	5/16 X 2 Grooved Clevis Pin	4
33.1.5	5053117	5/16 E Clip	4
33.1.6	5030924	AIXR RH Boom	1
33.2	5053111	Plastic Retaining Clip (11 Ga.)	1
33.3	5281062	3-Nozzle Harness	1
33.3.1	5281304	"ELL" Nozzle Sub-Assembly (3/8")	2
33.3.1.1	5056113	Single Hose Shank (3/8" Hose)	1
33.3.1.2	5143543	Check Valve Strainer, 50 Mesh, 5 PSI	1
33.3.1.3	5016157	Seat Washer (QJ Caps)	1
33.3.1.4	5018371	Air-Induction XR Flat Spray Tip (AIXR11002VP)	1
33.3.1.5	5046219	Quick TeeJet Cap ONLY (Yellow)	1
33.3.2	5051144	Hose Clamp, 3/8"	5
33.3.3	5020523	Hose, 3/8"-1 Brd. x 31"	2
33.3.4	5281308	"Cross" Nozzle Sub-Assembly (3/8")	1
33.3.4.1	5056115	Triple Hose Shank (3/8" Hose)	1
33.3.4.2	5143543	Check Valve Strainer, 50 Mesh, 5 PSI	1
33.3.4.3	5016157	Seat Washer (QJ Caps)	1
33.3.4.4	5018371	Air-Induction XR Flat Spray Tip (AIXR11002VP)	1
33.3.4.5	5046219	Quick TeeJet Cap ONLY (Yellow)	1
33.3.5	5020201	Hose, 3/8"-1 Brd. x 12"	1
34	5053110	Plastic Retaining Clip (14 & 16 Ga.)	2

Based on the minimum overlap required to obtain uniform distribution with 110° tips and 30" spacing.  
Suggested Minimum Spray Height: 20"-22" above what is being sprayed (to plant, not ground).  
Optimum Spray Height: 20"

- 110° wide, tapered flat spray angle with air induction technology for better drift management
- Made of 2-piece UHMWPE polymer construction which provides excellent chemical resistance, including acids, as well as exceptional wear life
- Compact size to prevent tip damage
- Excellent for systemic products and drift management

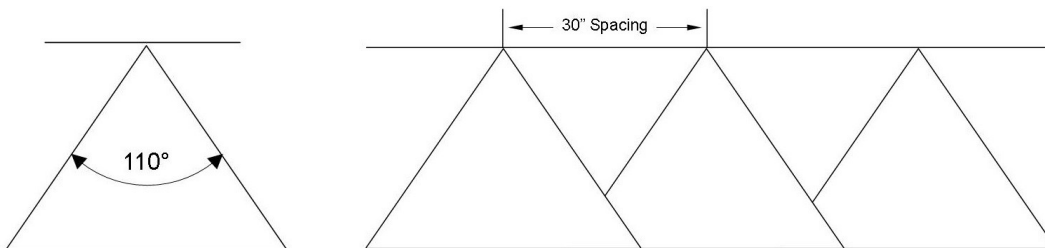

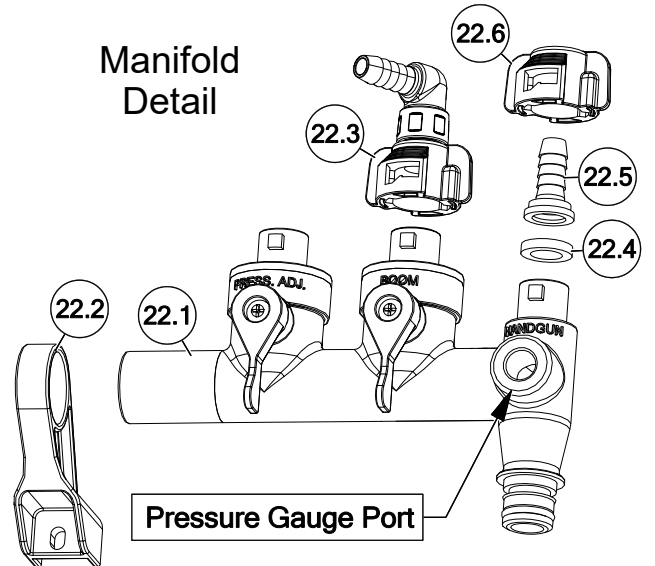
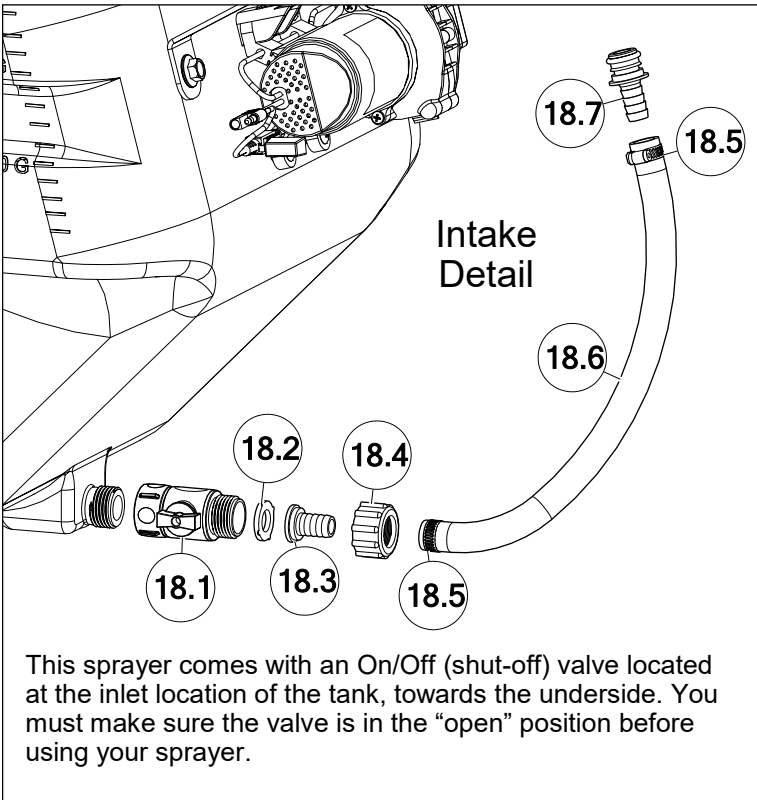

See Page 9  
for Part Numbers

**NOTES:**

# Warranty

## LIMITED WARRANTY FOR NEW FIMCO, IND. EQUIPMENT

**WHO MAY USE THIS LIMITED WARRANTY.** This limited warranty (the "Limited Warranty") is provided by Fimco, Ind. to the original purchaser ("you") of the Equipment (as defined below) from Fimco, Ind. or one of Fimco, Ind.'s authorized dealers. This Limited Warranty does not apply to any subsequent owner or other transferee of the Equipment. THIS LIMITED WARRANTY GIVES YOU SPECIFIC LEGAL RIGHTS, AND YOU MAY ALSO HAVE OTHER RIGHTS WHICH VARY FROM STATE TO STATE.

**WHAT THIS LIMITED WARRANTY COVERS AND FOR HOW LONG.** Fimco, Ind. warrants that any new Equipment will be free from defects in material and workmanship for a period of **one (1) year** for sprayer and **two (2) years** for High-Flo High Performance pump (homeowner), **90 days** for sprayer and pump (commercial user), after delivery of the Equipment to you (the "Warranty Period"). The Warranty Period is not extended if Fimco, Ind. repairs or replaces the Equipment.

**WHAT IS NOT COVERED BY THIS LIMITED WARRANTY.** This Limited Warranty does not apply to: (1) used Equipment; (2) any Equipment that has been altered, changed, repaired or treated since its delivery to you, other than by Fimco, Ind. or its authorized dealers; (3) damage or depreciation due to normal wear and tear; (4) defects or damage due to failure to follow Fimco, Ind.'s operator's manual, specifications or other written instructions, or improper storage, operation, maintenance, application or installation of parts; (5) defects or damage due to misuse, accident or neglect, "acts of God" or other events beyond Fimco, Ind.'s reasonable control; (6) accessories, attachments, tools or parts that were not manufactured by Fimco, Ind., whether or not sold or operated with the Equipment; or (7) rubber parts, such as tires, hoses and grommets.

**HOW TO OBTAIN WARRANTY SERVICE.** To obtain warranty service under this Limited Warranty, you must (1) provide written notice to Fimco, Ind. of the defect during the Warranty Period and within **thirty (30) days** after the defect becomes apparent or the repair becomes necessary, at the following address: Fimco, Ind., 1000 Fimco Lane, North Sioux City, SD 57049; and (2) make the Equipment available to Fimco, Ind. or an authorized dealer within a reasonable period of time. For more information about this Limited Warranty, please call: **800-831-0027**.

**WHAT REMEDIES ARE AVAILABLE UNDER THIS LIMITED WARRANTY.** If the conditions set forth above are fulfilled and the Equipment or any part thereof is found to be defective, Fimco, Ind. shall, at its own cost, and at its option, either repair or replace the defective Equipment or part. Fimco, Ind. will pay for shipping and handling fees to return the repaired or replacement Equipment or part to you.

**LIMITATION OF IMPLIED WARRANTIES AND OTHER REMEDIES.** THE REMEDIES DESCRIBED ABOVE ARE YOUR SOLE AND EXCLUSIVE REMEDIES, AND FIMCO, IND.'S SOLE LIABILITY, FOR ANY BREACH OF THIS LIMITED WARRANTY. TO THE EXTENT APPLICABLE, ANY IMPLIED WARRANTIES, INCLUDING, WITHOUT LIMITATION, THE IMPLIED WARRANTIES OF MERCHANTABILITY AND FITNESS FOR A PARTICULAR PURPOSE, SHALL BE LIMITED IN DURATION TO THE WARRANTY PERIOD, AND THE REMEDIES AVAILABLE FOR BREACH THEREOF SHALL BE LIMITED TO THE REMEDIES AVAILABLE UNDER THIS EXPRESS LIMITED WARRANTY. SOME STATES DO NOT ALLOW LIMITATIONS ON HOW LONG AN IMPLIED WARRANTY LASTS, SO THE ABOVE LIMITATION MAY NOT APPLY TO YOU. IN NO EVENT SHALL FIMCO, IND.'S LIABILITY UNDER THIS LIMITED WARRANTY EXCEED THE ACTUAL AMOUNT PAID BY YOU FOR THE DEFECTIVE EQUIPMENT, NOR SHALL FIMCO, IND. BE LIABLE, UNDER ANY CIRCUMSTANCES, FOR ANY CONSEQUENTIAL, INCIDENTAL, SPECIAL OR PUNITIVE DAMAGES OR LOSSES, WHETHER DIRECT OR INDIRECT. SOME STATES DO NOT ALLOW THE EXCLUSION OR LIMITATION OF INCIDENTAL OR CONSEQUENTIAL DAMAGES, SO THE ABOVE LIMITATION OR EXCLUSION MAY NOT APPLY TO YOU.