



PORTABLE AIR CIRCULATORS

Operating Instructions for Polyethylene (PE) Housing Portable Air Circulators

READ AND SAVE THESE INSTRUCTIONS

Your Maxx Air fan is shipped fully assembled. Enjoy the powerful, cooling breeze that the fan will provide for virtually any indoor application. There are no additional spare parts shipped with this item.

SPECIFICATIONS: 110-120 Volt A/C polarized grounded plug with 7 1/2 foot supply cord. Do not remove grounding conductor from lug or use with an extension cord.

WARNING: To reduce the risk of fire or electric shock, do not use with any solid state speed control device. This fan motor is equipped with an automatic reset overload device. The fan may start unexpectedly. Do not put any object through the grilles into the blade or motor.

This fan is designed for indoor use only. Do not expose to the elements or allow to become wet. Do not use to exhaust hazardous chemicals or vapors. Unplug unit for storage, when not in use or moving locations.

MAINTENANCE OR SERVICE INSTRUCTIONS: Always unplug or disconnect the fan from the power supply before servicing. Remove grilles to clean with mild detergent, allow to dry, and reinstall as previously installed.

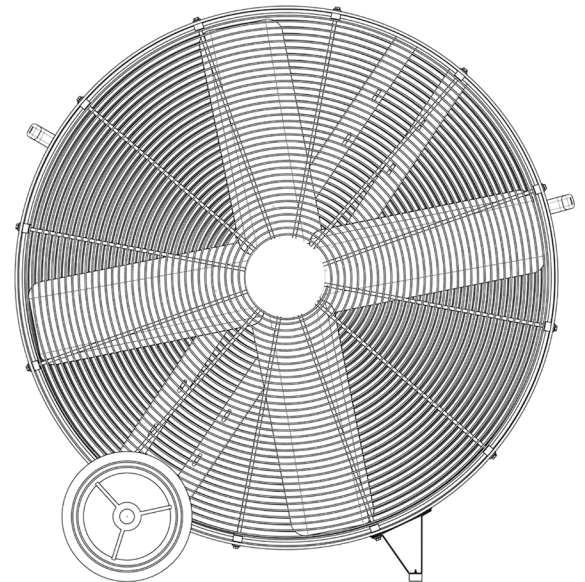

LEER Y GUARDAR ESTAS INSTRUCCIONES

INSTRUCCIONES:

ESPECIFICACIONES: Enchufe polarizado y puesto a tierra de 120V~ corriente alterna, con cable alimentador de 7 1/2 pies (2,2 metros). No hay que quitar el conductor a tierra de la agarradera ni usar con un cable alargador.

ADVERTENCIA: Para reducir el riesgo de incendio o electrochoque, no hay que usar con ningún dispositivo de estado sólido para control de velocidad.

El motor de este ventilador está provisto de un dispositivo de reenganche en caso de sobrecarga. El ventilador puede arrancarse inesperadamente. No hay que introducir objetos que desenchufarlo antes de guardarlo, cuando no esté en uso o al moverlo a otra parte.

INSTRUCCIONES PARA MANTENIMIENTO O SERVICIO: Siempre hay que desconectar el ventilador de la toma de corriente antes de hacerle un servicio. Hay que retirar las rejillas para limpiarlas con un detergente suave, dejarlas que se sequen y volver a instalar.

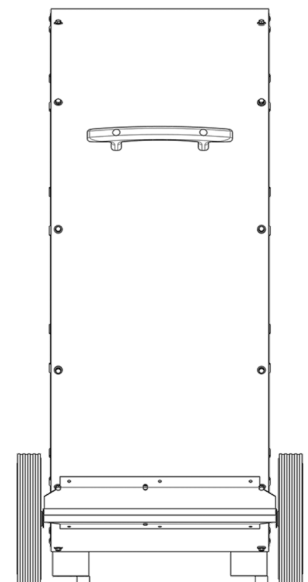

REPLACEMENT PARTS

For more information about ordering replacement parts, contact our customer service representatives at our toll-free number: 1-800-433-1626.

VENTAMATIC, Ltd. LIMITED WARRANTY

This warranty is underwritten by Falco Insurance Company and is extended to the original retail purchaser of this model or, if this unit is purchased and requires installation by a building contractor, to the original owner of the home. No subsequent purchaser of the unit or of a home in which it is installed is entitled to any of the benefits of this warranty.

This product is warranted against defects in materials and workmanship for a period of two (2) years from the date of original retail purchase. No other parts or components are warranted. There is no warranty for defects caused by abuse, faulty installation, or the like.

Repairs or replacement parts supplied under this warranty are warranted only for the period of this warranty; that is, two (2) years from the date of the original retail purchase of the unit.

In the event of a defect or malfunction, we will replace or repair the defective part or component only and return the new or repaired part to you freight prepaid.

You must bear all other expenses incurred in obtaining repairs, including labor required for field repair or replacement, and the cost of shipping the defective part to us. You must also bear the cost of repair to or replacement of any part or component and the shipping charges incurred for the repair or replacement and return to you of any part or component not covered by this warranty, including parts or components damaged by you.

The company reserves the right to demand and receive written evidence of the date of purchase before undertaking its obligations under this warranty. The right to demand and receive written evidence of date of purchase extends to all licensed dealers of Ventamatic, Ltd. products.

You should, therefore, retain your sales slip and attach a copy of it to the warranty claim.

To start a warranty claim you must:

Contact Ventamatic, Ltd.

An RGA (Returned Goods Authorization) form is required for returns to the factory to ensure your return can be processed efficiently and quickly. Please contact Ventamatic, Ltd. toll-free at 800-433-1626 or via web at www.MYMAXXAIR.com to obtain an RGA and follow the instructions given.

There is no informal dispute settling mechanism available in the event of a controversy involving this warranty.

Any and all implied warranties which may exist terminate upon the expiration of this warranty two (2) years from the date of the original retail purchase. Some states do not allow limitations on how long an implied warranty lasts, so this limitation may not apply to you.

Ventamatic, Ltd. is not liable to you for incidental or consequential damages arising out of defect or malfunction of a unit or its installation or out of any alleged breach of this warranty. Some states do not allow the exclusion or limitation of incidental or consequential damages, so this limitation may not apply to you. This warranty gives you specific legal rights and you may also have other rights which may vary from state to state.

rev.4/19