

ASSEMBLY INSTRUCTION





WICKER BAR HEIGHT BISTRO SET AW-226

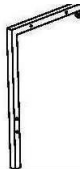

Thanks for your purchase of this Bistro Set. This bistro set includes a bar table and two chairs.

PART ONE CHAIR ASSEMBLY INSTRUCTION

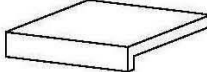
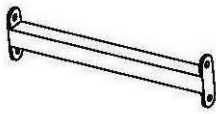
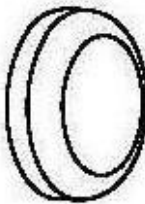
PART LIST FOR CHAIR

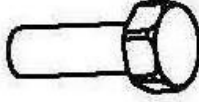
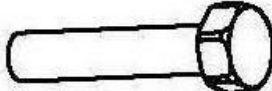
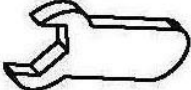
NO	SEAT BACK	QTY	NO	LEFT LEG	QTY
A		1PC	B		1PC
C	RIGHT LEG	1PC	D	SEAT	1PC
					
E	SUPPORT BAR	3PCS	F	NUT CAP	20PCS
					
G	WASHER	20PCS	H	M6*15 BOLT	14PCS
					
I	M6*40 BOLT	6PCS	J	SPANNER	1PC
		FOR SEAT ASSEMBLY			

CHAIR ASSEMBLY

Please do not fasten all bolts tightly until you finish the assembly. To do this, finger tighten all bolts firstly and after the assembly is finished, please use spanner to tighten all bolts firmly.

If you can not finger tighten the bolts, just use spanner to loosely tighten bolts.

STEP ONE

A) Attach Part B to Part A with 1pc M6*15 bolt and 1pc washer. Part B with screw holes must face inside. Please refer to picture right.

M6*15 1PC

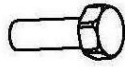

Washer 1PC



B) Attach Part C to Part A following the same steps as Instruction A.

M6*15 1PC

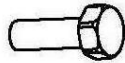

Washer 1PC

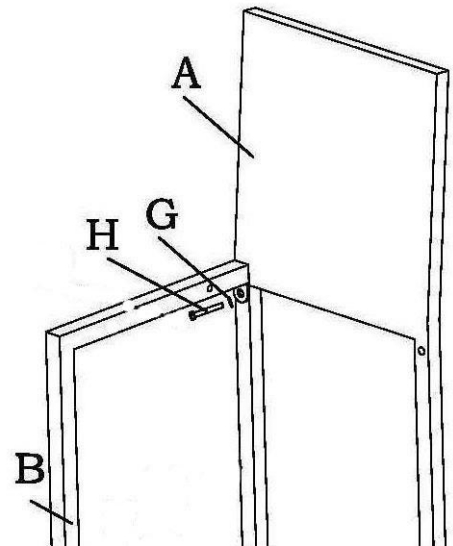

STEP TWO

A) Align Part E with Part B and Part A, then insert 4 pcs M6*15 bolt and 4 pcs washer at both ends and tighten Part E to Part B and Part A. Please refer to the picture on the right.

M6*15 4PCS

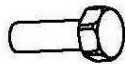

Washer 4PCS



B) Follow the above steps to fix Part C to Part A.

M6*15 4PCS

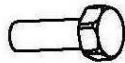

Washer 4PCS

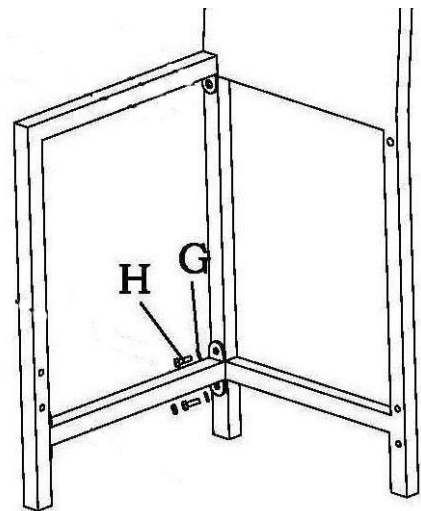

STEP THREE

Turn the chair upside down and align the seat (facing downwards) with Part A, Part B and Part C. Insert 6 pcs M6*40 bolt and 6 pcs washer, and finger tighten them. Please refer to the picture on the right.

M6*40 6PCS

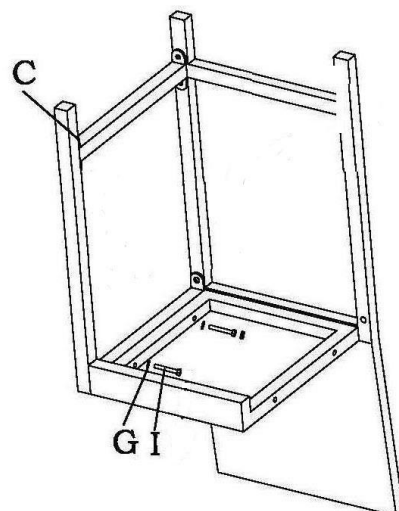

Washer 6PCS



STEP FOUR

Align Part E to Part B and Part C and finger tighten.
Please see picture right.

M6*15 4PCS

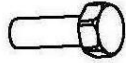

Washer 4PCS



After the assembly is done, please use wrench
to tighten all bolts firmly.

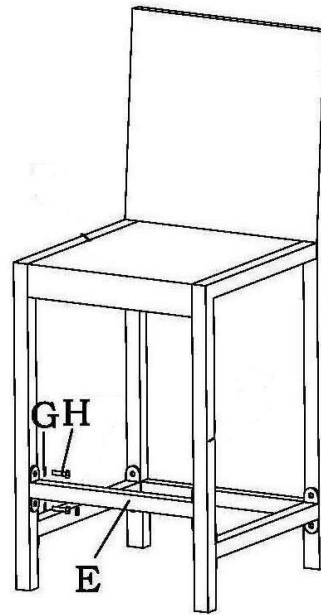

Put all nut caps on the bolts.



PART TWO TABLE ASSEMBLY INSTRUCTION

PART LIST FOR TABLE

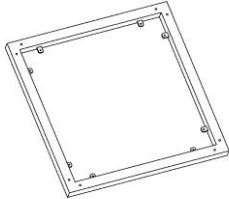
TABLE ASSEMBLY

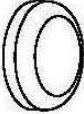
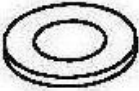
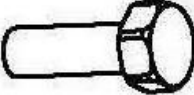
NO	TABLE TOP	QTY	NO	TABLE LEG	QTY
A		1PC	B		4PCS
C	SUPPORT LEG	4PCS	D	NUT CAP	24PC
					
E	WASHER	24PCS	F	M6*24 bolt	24PCS
					

Please do not fasten all bolts tightly until you finish the assembly. To do this, finger tighten all bolts first and after the assembly is finished, please use wrench to tighten all bolts firmly.

If you can not finger tighten the bolts, just use wrench to loosely tighten bolts.

STEP ONE

Attach 1pcs Part B table leg to Part A glass table top using 2pcs M6*24 bolt and 2pcs washer.

Follow the same step to attach remaining 3pcs Part B to Part A glass table top with 6pcs M6*24 bolt and 6pcs washer. Please see picture right.

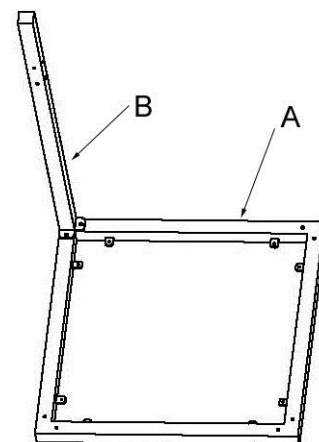

M6*24 8PCS 

Washer 8PCS 

STEP TWO

Align Part C support bar to Part B table leg with 4pcs M6*24 bolt and 4pcs washer.

Follow the same step to finish the assembly of remaining 3pcs Part C with Part with 12pcs M6*24 bolt and 12pcs washer.

After the assembly is done, please use wrench to tighten all bolts firmly.

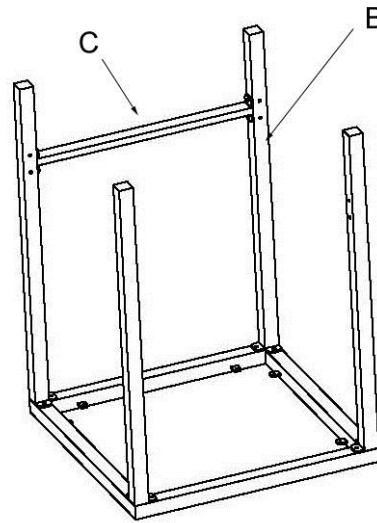

M6*24 16PCS

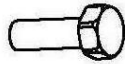

Washer 16PCS



Put all nut caps on the bolts.

DISTRUBITED BY
AZ PATIO HEATERS LLC
8550 N 91st Ave Ste C-25
Peoria, AZ 85345
PH. (623) 875-1330